

PROJECT MANUAL FOR

Highland Jr. High School Kitchen Remodel

325 Gramercy Ave.
Ogden, Utah 84404

for the

Ogden School District

Construction Documents



NJRA Architects, Inc. | 5272 South College Dr. | Murray, Utah 84123 | (801) 364-9259

PROJECT MANUAL INDEX

Title Page
 Project Manual Index
 Drawing Index

Bidding Documents

Notice to Contractors

A201 General Conditions
 A310 Bid Bond
 A312 Payment Bond
 A312 Performance Bond
 A701 Instructions to Bidders
 G702 Application & Certificate for Payment
 G703 Continuation of Sheet G702
 G704 Certificate of Substantial Completion
 G706A Contractors Affidavit to Release of Liens
 G707 Consent of Surety of Final Payment

Technical SpecificationsDivision 1 – General Requirements

00730	Supplementary Conditions
011000	Summary
012100	Allowances
012900	Payment Procedures
013100	Project Management and Coordination
013300	Submittal Procedures
014200	References
015000	Temporary Facilities
017310	Cutting & Patching
017700	Closeout Procedures
017823	Operation and Maintenance Data
017839	Project Record Documents

Division 2 – Existing Conditions

024119	Selective Demolition
--------	----------------------

Division 5 – Metals

051200	Structural Steel Framing
055000	Metal Fabrications

Division 6 – Wood, Plastics and Composites

061053	Miscellaneous Rough Carpentry
--------	-------------------------------

Division 7 – Thermal and Moisture Protection

079200	Joint Sealants
--------	----------------

Division 8 – Openings

081113	Hollow Metal Doors and Frames
083323	Overhead Coiling Doors
084113	Aluminum-Framed Entrances and Storefronts
087100	Door Hardware
088000	Glazing

Division 9 – Finishes

092216	Non-Structural Metal Framing
092900	Gypsum Board
093013	Ceramic Tiling
096530	Resilient Wall Base and Accessories
099000	Painting

Division 10 – Specialties

102800	Toilet, Bath, and Laundry Accessories
105113	Metal Lockers

Division 11 – Equipment

114000	Food Service Equipment
--------	------------------------

Division 12 – Furnishings

123661	Solid Surfacing Countertops
--------	-----------------------------

Division 22 - Plumbing

220500	Common Work Results for Plumbing
220519	Meters and Gages for Plumbing Piping
220529	Hangars and Supports for Plumbing Piping and Equipment
220553	Identification for Plumbing Piping
220700	Plumbing Insulation
221116	Domestic Water Piping
221119	Domestic Water Piping Specialties
221316	Storm, Sanitary Waste and Vent Piping
221319	Sanitary Waste Piping Specialties
224000	Plumbing Fixtures

Division 23 – Heating, Ventilating, and Air Conditioning

230500	Common Work Results for HVAC
230548	Vibration and Seismic Controls for HVAC Piping and Equipment
230553	Identification for HVAC Piping and Equipment
230593	Testing, Adjusting, and Balancing for HVAC
230700	HVAC Insulation
230900	Instrumentation and Control for HVAC
231123	Facility Natural-Gas Piping
232300	Refrigerant Piping
233113	Metal Ducts
233300	Air Duct Accessories
233423	HVAC Power Ventilators
237433	Packaged, Outdoor, Makeup Air-Units
238126	Interior VRF Units
238146	Air Cooled Unitary Heat Pumps

Division 26 – Electrical

260500	Electrical General Provisions
260502	Electrical Submittals and Spare Parts

260507	Electrical Connections for Equipment
260519	Conductors and Cables (600V and Below)
260526	Grounding
260519	Supporting Devices
260532	Conduit Raceway
260533	Electrical Boxes and Fittings
260553	Electrical Identification
260923	Occupancy Sensors
260943	Lighting Control Equipment
262416	Panelboards
262726	Wiring Devices
262816	Motor and Circuit Disconnects
262913	Motor Starters
264119	Demolition
265100	Interior and Exterior Building Lighting

Division 27 – Communications

271500	Telephone Data Systems
--------	------------------------

Division 28 – Electronic Safety & Security

283111	Fire Alarm & Detection System
--------	-------------------------------

DRAWING INDEXGENERAL DRAWINGS

G001	Title & Information Sheet
G002	General Information
G003	General Information
G004	American National Standard Institute Requirements
G005	General Legend & Notes

STRUCTURAL DRAWINGS

SE004	Structural Plans & Details
-------	----------------------------

ARCHITECTURAL DRAWINGS

A111	Demolition Floor Plan
A112	Demolition Reflected Ceiling Plan
A113	Floor Plan
A114	Dimension Floor Plan
A115	Reflected Ceiling Plan
A116	Finish Plan
A201	Interior Elevations & Wall Sections
A501	Wall Types
A502	Wall Details
A503	Wall Details
A504	Ceiling Details
A505	Door & Window Details
A601	Door Sched. & Types & Window Types
A602	Finish Schedule & Details

MECHANICAL DRAWINGS

MD111	Mechanical Demolition Plan
M111	Mechanical Floor Plan
M501	Mechanical Schedules

PLUMBING DRAWINGS

PD111	Plumbing Demotion Plans
P111	Plumbing Plan Water & Gas
P112	Plumbing Plan Waste & Vent

ELECTRICAL DRAWINGS

E001	Symbols, Schedules, & Notes
E101	Electrical Demolition Plan
E102	Main Level Lighting Plan
E301	Main Level Powers & Systems Plan

FOOD SERVICE DRAWINGS

FS101	Food Service Equipment Plan
FS102	Food Service Equipment Building Requirement Plan
FS103	Food Service Equipment Plumbing Requirement Plan
FS104	Food Service Equipment Electrical Requirement Plan

NOTICE TO CONTRACTORS- RFP 20-021 Highland Kitchen Remodel

Ogden School District
1950 Monroe Blvd.
Ogden, UT 84401

Ogden School District (OSD) will receive sealed bids on Wednesday **February 26, 2020** until 2:00 p.m. (prevailing Mountain Time) at Ogden School District, 1950 Monroe Blvd. Building 1 room 210, Ogden, UT 84401 for the construction & remodel of the Highland Jr. High School Kitchen. Bid Documents shall be turned into **Ken Crawford** in the OSD Purchasing Office. Outside of sealed envelope must be labeled **RFP 20-021**.

Electronic contract documents, dated January 30, 2020 may be obtained on **January 30, 2020** from the office of NJRA Architects, Inc. A download link can be requested via email to ezezen@njraarchitects (Zeke Zenger) or by calling the office directly at 801-364-9259.

A **mandatory Pre-Bid walk through** for General Contractors will be held on a **Thursday February 6, 2020 at 11:00 am** at the project site, Highland Junior High School, 325 Gramercy Ave. Ogden, UT. Meet at the South end of the school, at the loading dock outside of the Kitchen. Sub-contractors are welcome to attend but not mandatory. Product substitutions received after **February 19, 2020** shall not be accepted. All questions regarding this bid must be submitted to NJRA Architects via email to ezezen@njraarchitects (Zeke Zenger) by **February 19, 2020 by noon**.

The contract shall be awarded **March 19, 2020 pending board approval**. Pre-construction work performed by OSD (for existing equipment removal & abatement) will occur **May 26, 2020** through **May 29, 2020**. Construction may start **June 1, 2020**. Substantial Completion shall be **August 10, 2020**. Punchlist correction work and O&M Manual review to occur on **August 10, 2020** through **August 17, 2020**. Project Close Out will be **August 17, 2020** with liquidated damages to apply, as stated in these documents, beginning **August 18, 2020**. School will begin on **August 20, 2020**.

Bidders are required to submit a detailed construction schedule along with their bid. The schedule shall outline the proposed work and reflect the start and completion dates. Indicate the number of calendar days required to complete the project. A penalty of \$1,000.00 per calendar day will be assessed as liquidated damages in accordance with the General Conditions for each calendar day that the project is delayed after the scheduled completion date.

The Permit fees for this project shall be provided by the Owner. The contractor shall NOT include in the bid.

The owner reserves the right to reject any and all bids and to waive any irregularities in any bid or in the bidding.



AIA[®] Document A201[™] – 2017

General Conditions of the Contract for Construction

for the following PROJECT:
(Name and location or address)

THE OWNER:
(Name, legal status and address)

THE ARCHITECT:
(Name, legal status and address)

TABLE OF ARTICLES

1	GENERAL PROVISIONS
2	OWNER
3	CONTRACTOR
4	ARCHITECT
5	SUBCONTRACTORS
6	CONSTRUCTION BY OWNER OR BY SEPARATE CONTRACTORS
7	CHANGES IN THE WORK
8	TIME
9	PAYMENTS AND COMPLETION
10	PROTECTION OF PERSONS AND PROPERTY
11	INSURANCE AND BONDS
12	UNCOVERING AND CORRECTION OF WORK
13	MISCELLANEOUS PROVISIONS
14	TERMINATION OR SUSPENSION OF THE CONTRACT
15	CLAIMS AND DISPUTES

This document has important legal consequences. Consultation with an attorney is encouraged with respect to its completion or modification.

For guidance in modifying this document to include supplementary conditions, see AIA Document A503[™], Guide for Supplementary Conditions.

Init.

AIA Document A201[™] – 2017. Copyright © 1911, 1915, 1918, 1925, 1937, 1951, 1958, 1961, 1963, 1966, 1970, 1976, 1987, 1997, 2007 and 2017 by The American Institute of Architects. All rights reserved. **WARNING: This AIA[®] Document is protected by U.S. Copyright Law and International Treaties. Unauthorized reproduction or distribution of this AIA[®] Document, or any portion of it, may result in severe civil and criminal penalties, and will be prosecuted to the maximum extent possible under the law.** This document was produced by AIA software at 17:34:59 ET on 05/20/2019 under Order No.0077529913 which expires on 03/27/2020, and is not for resale.

User Notes:

(795946818)

INDEX

(Topics and numbers in bold are Section headings.)

Acceptance of Nonconforming Work

9.6.6, 9.9.3, **12.3**

Acceptance of Work

9.6.6, 9.8.2, 9.9.3, 9.10.1, 9.10.3, 12.3

Access to Work

3.16, 6.2.1, 12.1

Accident Prevention

10

Acts and Omissions

3.2, 3.3.2, 3.12.8, 3.18, 4.2.3, 8.3.1, 9.5.1, 10.2.5,

10.2.8, 13.3.2, 14.1, 15.1.2, 15.2

Addenda

1.1.1

Additional Costs, Claims for

3.7.4, 3.7.5, 10.3.2, 15.1.5

Additional Inspections and Testing

9.4.2, 9.8.3, 12.2.1, **13.4**

Additional Time, Claims for

3.2.4, 3.7.4, 3.7.5, 3.10.2, 8.3.2, **15.1.6**

Administration of the Contract

3.1.3, **4.2**, 9.4, 9.5

Advertisement or Invitation to Bid

1.1.1

Aesthetic Effect

4.2.13

Allowances

3.8

Applications for Payment

4.2.5, 7.3.9, 9.2, **9.3**, 9.4, 9.5.1, 9.5.4, 9.6.3, 9.7, 9.10

Approvals

2.1.1, 2.3.1, 2.5, 3.1.3, 3.10.2, 3.12.8, 3.12.9,

3.12.10.1, 4.2.7, 9.3.2, 13.4.1

Arbitration

8.3.1, 15.3.2, **15.4**

ARCHITECT

4

Architect, Definition of

4.1.1

Architect, Extent of Authority

2.5, 3.12.7, 4.1.2, 4.2, 5.2, 6.3, 7.1.2, 7.3.4, 7.4, 9.2,
9.3.1, 9.4, 9.5, 9.6.3, 9.8, 9.10.1, 9.10.3, 12.1, 12.2.1,
13.4.1, 13.4.2, 14.2.2, 14.2.4, 15.1.4, 15.2.1

Architect, Limitations of Authority and Responsibility

2.1.1, 3.12.4, 3.12.8, 3.12.10, 4.1.2, 4.2.1, 4.2.2, 4.2.3,
4.2.6, 4.2.7, 4.2.10, 4.2.12, 4.2.13, 5.2.1, 7.4, 9.4.2,
9.5.4, 9.6.4, 15.1.4, 15.2

Architect's Additional Services and Expenses

2.5, 12.2.1, 13.4.2, 13.4.3, 14.2.4

Architect's Administration of the Contract

3.1.3, 3.7.4, 15.2, 9.4.1, 9.5

Architect's Approvals

2.5, 3.1.3, 3.5, 3.10.2, 4.2.7

Architect's Authority to Reject Work

3.5, 4.2.6, 12.1.2, 12.2.1

Architect's Copyright

1.1.7, 1.5

Architect's Decisions

3.7.4, 4.2.6, 4.2.7, 4.2.11, 4.2.12, 4.2.13, 4.2.14, 6.3,
7.3.4, 7.3.9, 8.1.3, 8.3.1, 9.2, 9.4.1, 9.5, 9.8.4, 9.9.1,
13.4.2, 15.2

Architect's Inspections

3.7.4, 4.2.2, 4.2.9, 9.4.2, 9.8.3, 9.9.2, 9.10.1, 13.4

Architect's Instructions

3.2.4, 3.3.1, 4.2.6, 4.2.7, 13.4.2

Architect's Interpretations

4.2.11, 4.2.12

Architect's Project Representative

4.2.10

Architect's Relationship with Contractor

1.1.2, 1.5, 2.3.3, 3.1.3, 3.2.2, 3.2.3, 3.2.4, 3.3.1, 3.4.2,
3.5, 3.7.4, 3.7.5, 3.9.2, 3.9.3, 3.10, 3.11, 3.12, 3.16,
3.18, 4.1.2, 4.2, 5.2, 6.2.2, 7, 8.3.1, 9.2, 9.3, 9.4, 9.5,
9.7, 9.8, 9.9, 10.2.6, 10.3, 11.3, 12, 13.3.2, 13.4, 15.2

Architect's Relationship with Subcontractors

1.1.2, 4.2.3, 4.2.4, 4.2.6, 9.6.3, 9.6.4, 11.3

Architect's Representations

9.4.2, 9.5.1, 9.10.1

Architect's Site Visits

3.7.4, 4.2.2, 4.2.9, 9.4.2, 9.5.1, 9.9.2, 9.10.1, 13.4

Asbestos

10.3.1

Attorneys' Fees

3.18.1, 9.6.8, 9.10.2, 10.3.3

Award of Separate Contracts

6.1.1, 6.1.2

Award of Subcontracts and Other Contracts for Portions of the Work

5.2

Basic Definitions

1.1

Bidding Requirements

1.1.1

Binding Dispute Resolution

8.3.1, 9.7, 11.5, 13.1, 15.1.2, 15.1.3, 15.2.1, 15.2.5,
15.2.6.1, 15.3.1, 15.3.2, 15.3.3, 15.4.1

Bonds, Lien

7.3.4.4, 9.6.8, 9.10.2, 9.10.3

Bonds, Performance, and Payment

7.3.4.4, 9.6.7, 9.10.3, **11.1.2**, 11.1.3, **11.5**

Building Information Models Use and Reliance

1.8

Building Permit

3.7.1

Capitalization

1.3

Certificate of Substantial Completion

9.8.3, 9.8.4, 9.8.5

Init.

/

Certificates for Payment

4.2.1, 4.2.5, 4.2.9, 9.3.3, **9.4**, 9.5, 9.6.1, 9.6.6, 9.7, 9.10.1, 9.10.3, 14.1.1.3, 14.2.4, 15.1.4

Certificates of Inspection, Testing or Approval
13.4.4

Certificates of Insurance
9.10.2

Change Orders

1.1.1, 3.4.2, 3.7.4, 3.8.2.3, 3.11, 3.12.8, 4.2.8, 5.2.3, 7.1.2, 7.1.3, **7.2**, 7.3.2, 7.3.7, 7.3.9, 7.3.10, 8.3.1, 9.3.1.1, 9.10.3, 10.3.2, 11.2, 11.5, 12.1.2

Change Orders, Definition of

7.2.1

CHANGES IN THE WORK

2.2.2, 3.11, 4.2.8, **7**, 7.2.1, 7.3.1, 7.4, 8.3.1, 9.3.1.1, 11.5

Claims, Definition of

15.1.1

Claims, Notice of
1.6.2, 15.1.3

CLAIMS AND DISPUTES

3.2.4, 6.1.1, 6.3, 7.3.9, 9.3.3, 9.10.4, 10.3.3, **15**, 15.4
Claims and Timely Assertion of Claims
15.4.1

Claims for Additional Cost

3.2.4, 3.3.1, 3.7.4, 7.3.9, 9.5.2, 10.2.5, 10.3.2, **15.1.5**

Claims for Additional Time

3.2.4, 3.3.1, 3.7.4, 6.1.1, 8.3.2, 9.5.2, 10.3.2, **15.1.6**

Concealed or Unknown Conditions, Claims for

3.7.4

Claims for Damages
3.2.4, 3.18, 8.3.3, 9.5.1, 9.6.7, 10.2.5, 10.3.3, 11.3, 11.3.2, 14.2.4, 15.1.7

Claims Subject to Arbitration
15.4.1

Cleaning Up

3.15, 6.3

Commencement of the Work, Conditions Relating to
2.2.1, 3.2.2, 3.4.1, 3.7.1, 3.10.1, 3.12.6, 5.2.1, 5.2.3, 6.2.2, 8.1.2, 8.2.2, 8.3.1, 11.1, 11.2, **15.1.5**

Commencement of the Work, Definition of
8.1.2

Communications

3.9.1, **4.2.4**

Completion, Conditions Relating to
3.4.1, 3.11, 3.15, 4.2.2, 4.2.9, 8.2, 9.4.2, 9.8, 9.9.1, 9.10, 12.2, 14.1.2, 15.1.2

COMPLETION, PAYMENTS AND

9

Completion, Substantial
3.10.1, 4.2.9, 8.1.1, 8.1.3, 8.2.3, 9.4.2, 9.8, 9.9.1, 9.10.3, 12.2, 15.1.2
Compliance with Laws
2.3.2, 3.2.3, 3.6, 3.7, 3.12.10, 3.13, 9.6.4, 10.2.2, 13.1, 13.3, 13.4.1, 13.4.2, 13.5, 14.1.1, 14.2.1.3, 15.2.8, 15.4.2, 15.4.3

Concealed or Unknown Conditions

3.7.4, 4.2.8, 8.3.1, 10.3

Conditions of the Contract

1.1.1, 6.1.1, 6.1.4

Consent, Written

3.4.2, 3.14.2, 4.1.2, 9.8.5, 9.9.1, 9.10.2, 9.10.3, 13.2, 15.4.4.2

Consolidation or Joinder

15.4.4

CONSTRUCTION BY OWNER OR BY SEPARATE CONTRACTORS

1.1.4, **6**

Construction Change Directive, Definition of
7.3.1

Construction Change Directives

1.1.1, 3.4.2, 3.11, 3.12.8, 4.2.8, 7.1.1, 7.1.2, 7.1.3, **7.3**, 9.3.1.1

Construction Schedules, Contractor's

3.10, 3.11, 3.12.1, 3.12.2, 6.1.3, 15.1.6.2

Contingent Assignment of Subcontracts

5.4, 14.2.2.2

Continuing Contract Performance

15.1.4

Contract, Definition of

1.1.2

CONTRACT, TERMINATION OR SUSPENSION OF THE

5.4.1.1, 5.4.2, 11.5, **14**

Contract Administration

3.1.3, 4, 9.4, 9.5

Contract Award and Execution, Conditions Relating to

3.7.1, 3.10, 5.2, 6.1

Contract Documents, Copies Furnished and Use of
1.5.2, 2.3.6, 5.3

Contract Documents, Definition of

1.1.1

Contract Sum

2.2.2, 2.2.4, 3.7.4, 3.7.5, 3.8, 3.10.2, 5.2.3, 7.3, 7.4, **9.1**, 9.2, 9.4.2, 9.5.1.4, 9.6.7, 9.7, 10.3.2, 11.5, 12.1.2, 12.3, 14.2.4, 14.3.2, 15.1.4.2, **15.1.5**, **15.2.5**

Contract Sum, Definition of

9.1

Contract Time

1.1.4, 2.2.1, 2.2.2, 3.7.4, 3.7.5, 3.10.2, 5.2.3, 6.1.5, 7.2.1.3, 7.3.1, 7.3.5, 7.3.6, 7, 7, 7.3.10, 7.4, 8.1.1, 8.2.1, 8.2.3, 8.3.1, 9.5.1, 9.7, 10.3.2, 12.1.1, 12.1.2, 14.3.2, 15.1.4.2, 15.1.6.1, 15.2.5

Contract Time, Definition of

8.1.1

CONTRACTOR

3

Contractor, Definition of

3.1, **6.1.2**

Contractor's Construction and Submittal Schedules

3.10, 3.12.1, 3.12.2, 4.2.3, 6.1.3, 15.1.6.2

Init.

/

Contractor's Employees
2.2.4, 3.3.2, 3.4.3, 3.8.1, 3.9, 3.18.2, 4.2.3, 4.2.6, 10.2,
10.3, 11.3, 14.1, 14.2.1.1

Contractor's Liability Insurance

11.1

Contractor's Relationship with Separate Contractors
and Owner's Forces

3.12.5, 3.14.2, 4.2.4, 6, 11.3, 12.2.4

Contractor's Relationship with Subcontractors

1.2.2, 2.2.4, 3.3.2, 3.18.1, 3.18.2, 4.2.4, 5, 9.6.2, 9.6.7,
9.10.2, 11.2, 11.3, 11.4

Contractor's Relationship with the Architect

1.1.2, 1.5, 2.3.3, 3.1.3, 3.2.2, 3.2.3, 3.2.4, 3.3.1, 3.4.2,
3.5.1, 3.7.4, 3.10, 3.11, 3.12, 3.16, 3.18, 4.2, 5.2, 6.2.2,
7, 8.3.1, 9.2, 9.3, 9.4, 9.5, 9.7, 9.8, 9.9, 10.2.6, 10.3,
11.3, 12, 13.4, 15.1.3, 15.2.1

Contractor's Representations

3.2.1, 3.2.2, 3.5, 3.12.6, 6.2.2, 8.2.1, 9.3.3, 9.8.2

Contractor's Responsibility for Those Performing the
Work

3.3.2, 3.18, 5.3, 6.1.3, 6.2, 9.5.1, 10.2.8

Contractor's Review of Contract Documents

3.2

Contractor's Right to Stop the Work

2.2.2, 9.7

Contractor's Right to Terminate the Contract

14.1

Contractor's Submittals

3.10, 3.11, 3.12, 4.2.7, 5.2.1, 5.2.3, 9.2, 9.3, 9.8.2,
9.8.3, 9.9.1, 9.10.2, 9.10.3

Contractor's Superintendent

3.9, 10.2.6

Contractor's Supervision and Construction

Procedures

1.2.2, 3.3, 3.4, 3.12.10, 4.2.2, 4.2.7, 6.1.3, 6.2.4, 7.1.3,
7.3.4, 7.3.6, 8.2, 10, 12, 14, 15.1.4

Coordination and Correlation

1.2, 3.2.1, 3.3.1, 3.10, 3.12.6, 6.1.3, 6.2.1

Copies Furnished of Drawings and Specifications

1.5, 2.3.6, 3.11

Copyrights

1.5, **3.17**

Correction of Work

2.5, 3.7.3, 9.4.2, 9.8.2, 9.8.3, 9.9.1, 12.1.2, **12.2**, 12.3,
15.1.3.1, 15.1.3.2, 15.2.1

Correlation and Intent of the Contract Documents

1.2

Cost, Definition of

7.3.4

Costs

2.5, 3.2.4, 3.7.3, 3.8.2, 3.15.2, 5.4.2, 6.1.1, 6.2.3,
7.3.3.3, 7.3.4, 7.3.8, 7.3.9, 9.10.2, 10.3.2, 10.3.6, 11.2,
12.1.2, 12.2.1, 12.2.4, 13.4, 14

Cutting and Patching

3.14, 6.2.5

Damage to Construction of Owner or Separate
Contractors

3.14.2, 6.2.4, 10.2.1.2, 10.2.5, 10.4, 12.2.4

Damage to the Work

3.14.2, 9.9.1, 10.2.1.2, 10.2.5, 10.4, 12.2.4

Damages, Claims for

3.2.4, 3.18, 6.1.1, 8.3.3, 9.5.1, 9.6.7, 10.3.3, 11.3.2,
11.3, 14.2.4, 15.1.7

Damages for Delay

6.2.3, 8.3.3, 9.5.1.6, 9.7, 10.3.2, 14.3.2

Date of Commencement of the Work, Definition of

8.1.2

Date of Substantial Completion, Definition of

8.1.3

Day, Definition of

8.1.4

Decisions of the Architect

3.7.4, 4.2.6, 4.2.7, 4.2.11, 4.2.12, 4.2.13, 6.3, 7.3.4,
7.3.9, 8.1.3, 8.3.1, 9.2, 9.4, 9.5.1, 9.8.4, 9.9.1, 13.4.2,
14.2.2, 14.2.4, 15.1, 15.2

Decisions to Withhold Certification

9.4.1, **9.5**, 9.7, 14.1.1.3

Defective or Nonconforming Work, Acceptance,
Rejection and Correction of

2.5, 3.5, 4.2.6, 6.2.3, 9.5.1, 9.5.3, 9.6.6, 9.8.2, 9.9.3,
9.10.4, 12.2.1

Definitions

1.1, 2.1.1, 3.1.1, 3.5, 3.12.1, 3.12.2, 3.12.3, 4.1.1, 5.1,
6.1.2, 7.2.1, 7.3.1, 8.1, 9.1, 9.8.1, 15.1.1

Delays and Extensions of Time

3.2, **3.7.4**, 5.2.3, 7.2.1, 7.3.1, **7.4**, **8.3**, 9.5.1, **9.7**,
10.3.2, **10.4**, 14.3.2, **15.1.6**, 15.2.5

Digital Data Use and Transmission

1.7

Disputes

6.3, 7.3.9, 15.1, 15.2

Documents and Samples at the Site

3.11

Drawings, Definition of

1.1.5

Drawings and Specifications, Use and Ownership of

3.11

Effective Date of Insurance

8.2.2

Emergencies

10.4, 14.1.1.2, **15.1.5**

Employees, Contractor's

3.3.2, 3.4.3, 3.8.1, 3.9, 3.18.2, 4.2.3, 4.2.6, 10.2,
10.3.3, 11.3, 14.1, 14.2.1.1

Equipment, Labor, or Materials

1.1.3, 1.1.6, 3.4, 3.5, 3.8.2, 3.8.3, 3.12, 3.13, 3.15.1,
4.2.6, 4.2.7, 5.2.1, 6.2.1, 7.3.4, 9.3.2, 9.3.3, 9.5.1.3,
9.10.2, 10.2.1, 10.2.4, 14.2.1.1, 14.2.1.2

Execution and Progress of the Work

1.1.3, 1.2.1, 1.2.2, 2.3.4, 2.3.6, 3.1, 3.3.1, 3.4.1, 3.7.1,
3.10.1, 3.12, 3.14, 4.2, 6.2.2, 7.1.3, 7.3.6, 8.2, 9.5.1,
9.9.1, 10.2, 10.3, 12.1, 12.2, 14.2, 14.3.1, 15.1.4

Extensions of Time
3.2.4, 3.7.4, 5.2.3, 7.2.1, 7.3, 7.4, 9.5.1, 9.7, 10.3.2, 10.4, 14.3, 15.1.6, **15.2.5**

Failure of Payment
9.5.1.3, **9.7**, 9.10.2, 13.5, 14.1.1.3, 14.2.1.2

Faulty Work
(See Defective or Nonconforming Work)

Final Completion and Final Payment
4.2.1, 4.2.9, 9.8.2, **9.10**, 12.3, 14.2.4, 14.4.3

Financial Arrangements, Owner's
2.2.1, 13.2.2, 14.1.1.4

GENERAL PROVISIONS

1

Governing Law

13.1
Guarantees (See Warranty)

Hazardous Materials and Substances
10.2.4, **10.3**

Identification of Subcontractors and Suppliers
5.2.1

Indemnification
3.17, **3.18**, 9.6.8, 9.10.2, 10.3.3, 11.3

Information and Services Required of the Owner
2.1.2, **2.2**, 2.3, 3.2.2, 3.12.10.1, 6.1.3, 6.1.4, 6.2.5, 9.6.1, 9.9.2, 9.10.3, 10.3.3, 11.2, 13.4.1, 13.4.2, 14.1.1.4, 14.1.4, 15.1.4

Initial Decision

15.2

Initial Decision Maker, Definition of
1.1.8
Initial Decision Maker, Decisions
14.2.4, 15.1.4.2, 15.2.1, 15.2.2, 15.2.3, 15.2.4, 15.2.5
Initial Decision Maker, Extent of Authority
14.2.4, 15.1.4.2, 15.2.1, 15.2.2, 15.2.3, 15.2.4, 15.2.5

Injury or Damage to Person or Property
10.2.8, 10.4

Inspections
3.1.3, 3.3.3, 3.7.1, 4.2.2, 4.2.6, 4.2.9, 9.4.2, 9.8.3, 9.9.2, 9.10.1, 12.2.1, 13.4

Instructions to Bidders
1.1.1

Instructions to the Contractor
3.2.4, 3.3.1, 3.8.1, 5.2.1, 7, 8.2.2, 12, 13.4.2

Instruments of Service, Definition of

1.1.7

Insurance
6.1.1, 7.3.4, 8.2.2, 9.3.2, 9.8.4, 9.9.1, 9.10.2, 10.2.5, **11**

Insurance, Notice of Cancellation or Expiration
11.1.4, 11.2.3

Insurance, Contractor's Liability

11.1
Insurance, Effective Date of
8.2.2, 14.4.2

Insurance, Owner's Liability

11.2

Insurance, Property
10.2.5, 11.2, 11.4, 11.5

Insurance, Stored Materials
9.3.2

INSURANCE AND BONDS

11

Insurance Companies, Consent to Partial Occupancy
9.9.1

Insured loss, Adjustment and Settlement of
11.5

Intent of the Contract Documents
1.2.1, 4.2.7, 4.2.12, 4.2.13

Interest

13.5

Interpretation
1.1.8, 1.2.3, **1.4**, 4.1.1, 5.1, 6.1.2, 15.1.1

Interpretations, Written
4.2.11, 4.2.12

Judgment on Final Award
15.4.2

Labor and Materials, Equipment
1.1.3, 1.1.6, **3.4**, 3.5, 3.8.2, 3.8.3, 3.12, 3.13, 3.15.1, 5.2.1, 6.2.1, 7.3.4, 9.3.2, 9.3.3, 9.5.1.3, 9.10.2, 10.2.1, 10.2.4, 14.2.1.1, 14.2.1.2

Labor Disputes
8.3.1

Laws and Regulations
1.5, 2.3.2, 3.2.3, 3.2.4, 3.6, 3.7, 3.12.10, 3.13, 9.6.4, 9.9.1, 10.2.2, 13.1, 13.3.1, 13.4.2, 13.5, 14, 15.2.8, 15.4

Liens
2.1.2, 9.3.1, 9.3.3, 9.6.8, 9.10.2, 9.10.4, 15.2.8

Limitations, Statutes of
12.2.5, 15.1.2, 15.4.1.1

Limitations of Liability
3.2.2, 3.5, 3.12.10, 3.12.10.1, 3.17, 3.18.1, 4.2.6, 4.2.7, 6.2.2, 9.4.2, 9.6.4, 9.6.7, 9.6.8, 10.2.5, 10.3.3, 11.3, 12.2.5, 13.3.1

Limitations of Time
2.1.2, 2.2, 2.5, 3.2.2, 3.10, 3.11, 3.12.5, 3.15.1, 4.2.7, 5.2, 5.3, 5.4.1, 6.2.4, 7.3, 7.4, 8.2, 9.2, 9.3.1, 9.3.3, 9.4.1, 9.5, 9.6, 9.7, 9.8, 9.9, 9.10, 12.2, 13.4, 14, 15, 15.1.2, 15.1.3, 15.1.5

Materials, Hazardous

10.2.4, 10.3

Materials, Labor, Equipment and
1.1.3, 1.1.6, 3.4.1, 3.5, 3.8.2, 3.8.3, 3.12, 3.13, 3.15.1, 5.2.1, 6.2.1, 7.3.4, 9.3.2, 9.3.3, 9.5.1.3, 9.10.2, 10.2.1.2, 10.2.4, 14.2.1.1, 14.2.1.2

Means, Methods, Techniques, Sequences and Procedures of Construction
3.3.1, 3.12.10, 4.2.2, 4.2.7, 9.4.2

Mechanic's Lien
2.1.2, 9.3.1, 9.3.3, 9.6.8, 9.10.2, 9.10.4, 15.2.8

Mediation
8.3.1, 15.1.3.2, 15.2.1, 15.2.5, 15.2.6, **15.3**, 15.4.1, 15.4.1.1

Minor Changes in the Work
1.1.1, 3.4.2, 3.12.8, 4.2.8, 7.1, **7.4**

MISCELLANEOUS PROVISIONS

13

Modifications, Definition of

1.1.1

Modifications to the Contract

1.1.1, 1.1.2, 2.5, 3.11, 4.1.2, 4.2.1, 5.2.3, 7, 8.3.1, 9.7, 10.3.2

Mutual Responsibility

6.2

Nonconforming Work, Acceptance of

9.6.6, 9.9.3, **12.3**

Nonconforming Work, Rejection and Correction of
2.4, 2.5, 3.5, 4.2.6, 6.2.4, 9.5.1, 9.8.2, 9.9.3, 9.10.4, 12.2

Notice

1.6, 1.6.1, 1.6.2, 2.1.2, 2.2.2., 2.2.3, 2.2.4, 2.5, 3.2.4, 3.3.1, 3.7.4, 3.7.5, 3.9.2, 3.12.9, 3.12.10, 5.2.1, 7.4, 8.2.2, 9.6.8, 9.7, 9.10.1, 10.2.8, 10.3.2, 11.5, 12.2.2.1, 13.4.1, 13.4.2, 14.1, 14.2.2, 14.4.2, 15.1.3, 15.1.5, 15.1.6, 15.4.1

Notice of Cancellation or Expiration of Insurance

11.1.4, 11.2.3

Notice of Claims

1.6.2, 2.1.2, 3.7.4, 9.6.8, 10.2.8, **15.1.3**, 15.1.5, 15.1.6, 15.2.8, 15.3.2, 15.4.1

Notice of Testing and Inspections

13.4.1, 13.4.2

Observations, Contractor's

3.2, 3.7.4

Occupancy

2.3.1, 9.6.6, 9.8

Orders, Written

1.1.1, 2.4, 3.9.2, 7, 8.2.2, 11.5, 12.1, 12.2.2.1, 13.4.2, 14.3.1

OWNER

2

Owner, Definition of

2.1.1

Owner, Evidence of Financial Arrangements

2.2, 13.2.2, 14.1.1.4

Owner, Information and Services Required of the

2.1.2, **2.2**, 2.3, 3.2.2, 3.12.10, 6.1.3, 6.1.4, 6.2.5, 9.3.2, 9.6.1, 9.6.4, 9.9.2, 9.10.3, 10.3.3, 11.2, 13.4.1, 13.4.2, 14.1.1.4, 14.1.4, 15.1.4

Owner's Authority

1.5, 2.1.1, 2.3.32.4, 2.5, 3.4.2, 3.8.1, 3.12.10, 3.14.2, 4.1.2, 4.2.4, 4.2.9, 5.2.1, 5.2.4, 5.4.1, 6.1, 6.3, 7.2.1, 7.3.1, 8.2.2, 8.3.1, 9.3.2, 9.5.1, 9.6.4, 9.9.1, 9.10.2, 10.3.2, 11.4, 11.5, 12.2.2, 12.3, 13.2.2, 14.3, 14.4, 15.2.7

Owner's Insurance

11.2

Owner's Relationship with Subcontractors

1.1.2, 5.2, 5.3, 5.4, 9.6.4, 9.10.2, 14.2.2

Owner's Right to Carry Out the Work

2.5, 14.2.2

Owner's Right to Clean Up

6.3

Owner's Right to Perform Construction and to Award Separate Contracts

6.1

Owner's Right to Stop the Work

2.4

Owner's Right to Suspend the Work

14.3

Owner's Right to Terminate the Contract

14.2, 14.4

Ownership and Use of Drawings, Specifications and Other Instruments of Service

1.1.1, 1.1.6, 1.1.7, **1.5**, 2.3.6, 3.2.2, 3.11, 3.17, 4.2.12, 5.3

Partial Occupancy or Use

9.6.6, **9.9**

Patching, Cutting and

3.14, 6.2.5

Patents

3.17

Payment, Applications for

4.2.5, 7.3.9, 9.2, **9.3**, 9.4, 9.5, 9.6.3, 9.7, 9.8.5, 9.10.1, 14.2.3, 14.2.4, 14.4.3

Payment, Certificates for

4.2.5, 4.2.9, 9.3.3, **9.4**, 9.5, 9.6.1, 9.6.6, 9.7, 9.10.1, 9.10.3, 14.1.1.3, 14.2.4

Payment, Failure of

9.5.1.3, **9.7**, 9.10.2, 13.5, 14.1.1.3, 14.2.1.2

Payment, Final

4.2.1, 4.2.9, **9.10**, 12.3, 14.2.4, 14.4.3

Payment Bond, Performance Bond and

7.3.4.4, 9.6.7, 9.10.3, **11.1.2**

Payments, Progress

9.3, **9.6**, 9.8.5, 9.10.3, 14.2.3, 15.1.4

PAYMENTS AND COMPLETION

9

Payments to Subcontractors

5.4.2, 9.5.1.3, 9.6.2, 9.6.3, 9.6.4, 9.6.7, 14.2.1.2

PCB

10.3.1

Performance Bond and Payment Bond

7.3.4.4, 9.6.7, 9.10.3, **11.1.2**

Permits, Fees, Notices and Compliance with Laws

2.3.1, **3.7**, 3.13, 7.3.4.4, 10.2.2

PERSONS AND PROPERTY, PROTECTION OF

10

Polychlorinated Biphenyl

10.3.1

Product Data, Definition of

3.12.2

Product Data and Samples, Shop Drawings

3.11, **3.12**, 4.2.7

Progress and Completion

4.2.2, **8.2**, 9.8, 9.9.1, 14.1.4, 15.1.4

Progress Payments

9.3, **9.6**, 9.8.5, 9.10.3, 14.2.3, 15.1.4

Init.

/

Project, Definition of
1.1.4
Project Representatives
4.2.10
Property Insurance
10.2.5, **11.2**
Proposal Requirements
1.1.1
PROTECTION OF PERSONS AND PROPERTY
10
Regulations and Laws
1.5, 2.3.2, 3.2.3, 3.6, 3.7, 3.12.10, 3.13, 9.6.4, 9.9.1,
10.2.2, 13.1, 13.3, 13.4.1, 13.4.2, 13.5, 14, 15.2.8, 15.4
Rejection of Work
4.2.6, 12.2.1
Releases and Waivers of Liens
9.3.1, 9.10.2
Representations
3.2.1, 3.5, 3.12.6, 8.2.1, 9.3.3, 9.4.2, 9.5.1, 9.10.1
Representatives
2.1.1, 3.1.1, 3.9, 4.1.1, 4.2.10, 13.2.1
Responsibility for Those Performing the Work
3.3.2, 3.18, 4.2.2, 4.2.3, 5.3, 6.1.3, 6.2, 6.3, 9.5.1, 10
Retainage
9.3.1, 9.6.2, 9.8.5, 9.9.1, 9.10.2, 9.10.3
Review of Contract Documents and Field
Conditions by Contractor
3.2, 3.12.7, 6.1.3
Review of Contractor's Submittals by Owner and
Architect
3.10.1, 3.10.2, 3.11, 3.12, 4.2, 5.2, 6.1.3, 9.2, 9.8.2
Review of Shop Drawings, Product Data and Samples
by Contractor
3.12
Rights and Remedies
1.1.2, 2.4, 2.5, 3.5, 3.7.4, 3.15.2, 4.2.6, 5.3, 5.4, 6.1,
6.3, 7.3.1, 8.3, 9.5.1, 9.7, 10.2.5, 10.3, 12.2.1, 12.2.2,
12.2.4, **13.3**, 14, 15.4
Royalties, Patents and Copyrights
3.17
Rules and Notices for Arbitration
15.4.1
Safety of Persons and Property
10.2, 10.4
Safety Precautions and Programs
3.3.1, 4.2.2, 4.2.7, 5.3, **10.1**, 10.2, 10.4
Samples, Definition of
3.12.3
Samples, Shop Drawings, Product Data and
3.11, **3.12**, 4.2.7
Samples at the Site, Documents and
3.11
Schedule of Values
9.2, 9.3.1
Schedules, Construction
3.10, 3.12.1, 3.12.2, 6.1.3, 15.1.6.2

Separate Contracts and Contractors
1.1.4, 3.12.5, 3.14.2, 4.2.4, 4.2.7, 6, 8.3.1, 12.1.2
Separate Contractors, Definition of
6.1.1
Shop Drawings, Definition of
3.12.1
Shop Drawings, Product Data and Samples
3.11, **3.12**, 4.2.7
Site, Use of
3.13, 6.1.1, 6.2.1
Site Inspections
3.2.2, 3.3.3, 3.7.1, 3.7.4, 4.2, 9.9.2, 9.4.2, 9.10.1, 13.4
Site Visits, Architect's
3.7.4, 4.2.2, 4.2.9, 9.4.2, 9.5.1, 9.9.2, 9.10.1, 13.4
Special Inspections and Testing
4.2.6, 12.2.1, 13.4
Specifications, Definition of
1.1.6
Specifications
1.1.1, **1.1.6**, 1.2.2, 1.5, 3.12.10, 3.17, 4.2.14
Statute of Limitations
15.1.2, 15.4.1.1
Stopping the Work
2.2.2, 2.4, 9.7, 10.3, 14.1
Stored Materials
6.2.1, 9.3.2, 10.2.1.2, 10.2.4
Subcontractor, Definition of
5.1.1
SUBCONTRACTORS
5
Subcontractors, Work by
1.2.2, 3.3.2, 3.12.1, 3.18, 4.2.3, 5.2.3, 5.3, 5.4, 9.3.1.2,
9.6.7
Subcontractual Relations
5.3, 5.4, 9.3.1.2, 9.6, 9.10, 10.2.1, 14.1, 14.2.1
Submittals
3.10, 3.11, 3.12, 4.2.7, 5.2.1, 5.2.3, 7.3.4, 9.2, 9.3, 9.8,
9.9.1, 9.10.2, 9.10.3
Submittal Schedule
3.10.2, 3.12.5, 4.2.7
Subrogation, Waivers of
6.1.1, **11.3**
Substances, Hazardous
10.3
Substantial Completion
4.2.9, 8.1.1, 8.1.3, 8.2.3, 9.4.2, **9.8**, 9.9.1, 9.10.3, 12.2,
15.1.2
Substantial Completion, Definition of
9.8.1
Substitution of Subcontractors
5.2.3, 5.2.4
Substitution of Architect
2.3.3
Substitutions of Materials
3.4.2, 3.5, 7.3.8
Sub-subcontractor, Definition of
5.1.2

Subsurface Conditions

3.7.4

Successors and Assigns

13.2

Superintendent

3.9, 10.2.6

Supervision and Construction Procedures

1.2.2, **3.3**, 3.4, 3.12.10, 4.2.2, 4.2.7, 6.1.3, 6.2.4, 7.1.3, 7.3.4, 8.2, 8.3.1, 9.4.2, 10, 12, 14, 15.1.4

Suppliers

1.5, 3.12.1, 4.2.4, 4.2.6, 5.2.1, 9.3, 9.4.2, 9.5.4, 9.6, 9.10.5, 14.2.1

Surety

5.4.1.2, 9.6.8, 9.8.5, 9.10.2, 9.10.3, 11.1.2, 14.2.2, 15.2.7

Surety, Consent of

9.8.5, 9.10.2, 9.10.3

Surveys

1.1.7, 2.3.4

Suspension by the Owner for Convenience

14.3

Suspension of the Work

3.7.5, 5.4.2, 14.3

Suspension or Termination of the Contract

5.4.1.1, 14

Taxes

3.6, 3.8.2.1, 7.3.4.4

Termination by the Contractor

14.1, 15.1.7

Termination by the Owner for Cause

5.4.1.1, **14.2**, 15.1.7

Termination by the Owner for Convenience

14.4

Termination of the Architect

2.3.3

Termination of the Contractor Employment

14.2.2

TERMINATION OR SUSPENSION OF THE CONTRACT

14

Tests and Inspections

3.1.3, 3.3.3, 3.7.1, 4.2.2, 4.2.6, 4.2.9, 9.4.2, 9.8.3, 9.9.2, 9.10.1, 10.3.2, 12.2.1, **13.4**

TIME

8

Time, Delays and Extensions of

3.2.4, 3.7.4, 5.2.3, 7.2.1, 7.3.1, 7.4, **8.3**, 9.5.1, 9.7, 10.3.2, 10.4, 14.3.2, 15.1.6, 15.2.5

Time Limits

2.1.2, 2.2, 2.5, 3.2.2, 3.10, 3.11, 3.12.5, 3.15.1, 4.2, 5.2, 5.3, 5.4, 6.2.4, 7.3, 7.4, 8.2, 9.2, 9.3.1, 9.3.3, 9.4.1, 9.5, 9.6, 9.7, 9.8, 9.9, 9.10, 12.2, 13.4, 14, 15.1.2, 15.1.3, 15.4

Time Limits on Claims

3.7.4, 10.2.8, 15.1.2, 15.1.3

Title to Work

9.3.2, 9.3.3

UNCOVERING AND CORRECTION OF WORK

12

Uncovering of Work

12.1

Unforeseen Conditions, Concealed or Unknown

3.7.4, 8.3.1, 10.3

Unit Prices

7.3.3.2, 9.1.2

Use of Documents

1.1.1, 1.5, 2.3.6, 3.12.6, 5.3

Use of Site

3.13, 6.1.1, 6.2.1

Values, Schedule of

9.2, 9.3.1

Waiver of Claims by the Architect

13.3.2

Waiver of Claims by the Contractor

9.10.5, 13.3.2, **15.1.7**

Waiver of Claims by the Owner

9.9.3, 9.10.3, 9.10.4, 12.2.2.1, 13.3.2, 14.2.4, **15.1.7**

Waiver of Consequential Damages

14.2.4, 15.1.7

Waiver of Liens

9.3, 9.10.2, 9.10.4

Waivers of Subrogation

6.1.1, **11.3**

Warranty

3.5, 4.2.9, 9.3.3, 9.8.4, 9.9.1, 9.10.2, 9.10.4, 12.2.2, 15.1.2

Weather Delays

8.3, 15.1.6.2

Work, Definition of

1.1.3

Written Consent

1.5.2, 3.4.2, 3.7.4, 3.12.8, 3.14.2, 4.1.2, 9.3.2, 9.10.3, 13.2, 13.3.2, 15.4.4.2

Written Interpretations

4.2.11, 4.2.12

Written Orders

1.1.1, 2.4, 3.9, 7, 8.2.2, 12.1, 12.2, 13.4.2, 14.3.1

Init.

/

ARTICLE 1 GENERAL PROVISIONS

§ 1.1 Basic Definitions

§ 1.1.1 The Contract Documents

The Contract Documents are enumerated in the Agreement between the Owner and Contractor (hereinafter the Agreement) and consist of the Agreement, Conditions of the Contract (General, Supplementary and other Conditions), Drawings, Specifications, Addenda issued prior to execution of the Contract, other documents listed in the Agreement, and Modifications issued after execution of the Contract. A Modification is (1) a written amendment to the Contract signed by both parties, (2) a Change Order, (3) a Construction Change Directive, or (4) a written order for a minor change in the Work issued by the Architect. Unless specifically enumerated in the Agreement, the Contract Documents do not include the advertisement or invitation to bid, Instructions to Bidders, sample forms, other information furnished by the Owner in anticipation of receiving bids or proposals, the Contractor's bid or proposal, or portions of Addenda relating to bidding or proposal requirements.

§ 1.1.2 The Contract

The Contract Documents form the Contract for Construction. The Contract represents the entire and integrated agreement between the parties hereto and supersedes prior negotiations, representations, or agreements, either written or oral. The Contract may be amended or modified only by a Modification. The Contract Documents shall not be construed to create a contractual relationship of any kind (1) between the Contractor and the Architect or the Architect's consultants, (2) between the Owner and a Subcontractor or a Sub-subcontractor, (3) between the Owner and the Architect or the Architect's consultants, or (4) between any persons or entities other than the Owner and the Contractor. The Architect shall, however, be entitled to performance and enforcement of obligations under the Contract intended to facilitate performance of the Architect's duties.

§ 1.1.3 The Work

The term "Work" means the construction and services required by the Contract Documents, whether completed or partially completed, and includes all other labor, materials, equipment, and services provided or to be provided by the Contractor to fulfill the Contractor's obligations. The Work may constitute the whole or a part of the Project.

§ 1.1.4 The Project

The Project is the total construction of which the Work performed under the Contract Documents may be the whole or a part and which may include construction by the Owner and by Separate Contractors.

§ 1.1.5 The Drawings

The Drawings are the graphic and pictorial portions of the Contract Documents showing the design, location and dimensions of the Work, generally including plans, elevations, sections, details, schedules, and diagrams.

§ 1.1.6 The Specifications

The Specifications are that portion of the Contract Documents consisting of the written requirements for materials, equipment, systems, standards and workmanship for the Work, and performance of related services.

§ 1.1.7 Instruments of Service

Instruments of Service are representations, in any medium of expression now known or later developed, of the tangible and intangible creative work performed by the Architect and the Architect's consultants under their respective professional services agreements. Instruments of Service may include, without limitation, studies, surveys, models, sketches, drawings, specifications, and other similar materials.

§ 1.1.8 Initial Decision Maker

The Initial Decision Maker is the person identified in the Agreement to render initial decisions on Claims in accordance with Section 15.2. The Initial Decision Maker shall not show partiality to the Owner or Contractor and shall not be liable for results of interpretations or decisions rendered in good faith.

§ 1.2 Correlation and Intent of the Contract Documents

§ 1.2.1 The intent of the Contract Documents is to include all items necessary for the proper execution and completion of the Work by the Contractor. The Contract Documents are complementary, and what is required by one shall be as binding as if required by all; performance by the Contractor shall be required only to the extent consistent with the Contract Documents and reasonably inferable from them as being necessary to produce the indicated results.

§ 1.2.1.1 The invalidity of any provision of the Contract Documents shall not invalidate the Contract or its remaining provisions. If it is determined that any provision of the Contract Documents violates any law, or is otherwise invalid or unenforceable, then that provision shall be revised to the extent necessary to make that provision legal and enforceable. In such case the Contract Documents shall be construed, to the fullest extent permitted by law, to give effect to the parties' intentions and purposes in executing the Contract.

§ 1.2.2 Organization of the Specifications into divisions, sections and articles, and arrangement of Drawings shall not control the Contractor in dividing the Work among Subcontractors or in establishing the extent of Work to be performed by any trade.

§ 1.2.3 Unless otherwise stated in the Contract Documents, words that have well-known technical or construction industry meanings are used in the Contract Documents in accordance with such recognized meanings.

§ 1.3 Capitalization

Terms capitalized in these General Conditions include those that are (1) specifically defined, (2) the titles of numbered articles, or (3) the titles of other documents published by the American Institute of Architects.

§ 1.4 Interpretation

In the interest of brevity the Contract Documents frequently omit modifying words such as "all" and "any" and articles such as "the" and "an," but the fact that a modifier or an article is absent from one statement and appears in another is not intended to affect the interpretation of either statement.

§ 1.5 Ownership and Use of Drawings, Specifications, and Other Instruments of Service

§ 1.5.1 The Architect and the Architect's consultants shall be deemed the authors and owners of their respective Instruments of Service, including the Drawings and Specifications, and retain all common law, statutory, and other reserved rights in their Instruments of Service, including copyrights. The Contractor, Subcontractors, Sub-subcontractors, and suppliers shall not own or claim a copyright in the Instruments of Service. Submittal or distribution to meet official regulatory requirements or for other purposes in connection with the Project is not to be construed as publication in derogation of the Architect's or Architect's consultants' reserved rights.

§ 1.5.2 The Contractor, Subcontractors, Sub-subcontractors, and suppliers are authorized to use and reproduce the Instruments of Service provided to them, subject to any protocols established pursuant to Sections 1.7 and 1.8, solely and exclusively for execution of the Work. All copies made under this authorization shall bear the copyright notice, if any, shown on the Instruments of Service. The Contractor, Subcontractors, Sub-subcontractors, and suppliers may not use the Instruments of Service on other projects or for additions to the Project outside the scope of the Work without the specific written consent of the Owner, Architect, and the Architect's consultants.

§ 1.6 Notice

§ 1.6.1 Except as otherwise provided in Section 1.6.2, where the Contract Documents require one party to notify or give notice to the other party, such notice shall be provided in writing to the designated representative of the party to whom the notice is addressed and shall be deemed to have been duly served if delivered in person, by mail, by courier, or by electronic transmission if a method for electronic transmission is set forth in the Agreement.

§ 1.6.2 Notice of Claims as provided in Section 15.1.3 shall be provided in writing and shall be deemed to have been duly served only if delivered to the designated representative of the party to whom the notice is addressed by certified or registered mail, or by courier providing proof of delivery.

§ 1.7 Digital Data Use and Transmission

The parties shall agree upon protocols governing the transmission and use of Instruments of Service or any other information or documentation in digital form. The parties will use AIA Document E203™–2013, Building Information Modeling and Digital Data Exhibit, to establish the protocols for the development, use, transmission, and exchange of digital data.

§ 1.8 Building Information Models Use and Reliance

Any use of, or reliance on, all or a portion of a building information model without agreement to protocols governing the use of, and reliance on, the information contained in the model and without having those protocols set forth in AIA Document E203™–2013, Building Information Modeling and Digital Data Exhibit, and the requisite AIA Document

G202™–2013, Project Building Information Modeling Protocol Form, shall be at the using or relying party's sole risk and without liability to the other party and its contractors or consultants, the authors of, or contributors to, the building information model, and each of their agents and employees.

ARTICLE 2 OWNER

§ 2.1 General

§ 2.1.1 The Owner is the person or entity identified as such in the Agreement and is referred to throughout the Contract Documents as if singular in number. The Owner shall designate in writing a representative who shall have express authority to bind the Owner with respect to all matters requiring the Owner's approval or authorization. Except as otherwise provided in Section 4.2.1, the Architect does not have such authority. The term "Owner" means the Owner or the Owner's authorized representative.

§ 2.1.2 The Owner shall furnish to the Contractor, within fifteen days after receipt of a written request, information necessary and relevant for the Contractor to evaluate, give notice of, or enforce mechanic's lien rights. Such information shall include a correct statement of the record legal title to the property on which the Project is located, usually referred to as the site, and the Owner's interest therein.

§ 2.2 Evidence of the Owner's Financial Arrangements

§ 2.2.1 Prior to commencement of the Work and upon written request by the Contractor, the Owner shall furnish to the Contractor reasonable evidence that the Owner has made financial arrangements to fulfill the Owner's obligations under the Contract. The Contractor shall have no obligation to commence the Work until the Owner provides such evidence. If commencement of the Work is delayed under this Section 2.2.1, the Contract Time shall be extended appropriately.

§ 2.2.2 Following commencement of the Work and upon written request by the Contractor, the Owner shall furnish to the Contractor reasonable evidence that the Owner has made financial arrangements to fulfill the Owner's obligations under the Contract only if (1) the Owner fails to make payments to the Contractor as the Contract Documents require; (2) the Contractor identifies in writing a reasonable concern regarding the Owner's ability to make payment when due; or (3) a change in the Work materially changes the Contract Sum. If the Owner fails to provide such evidence, as required, within fourteen days of the Contractor's request, the Contractor may immediately stop the Work and, in that event, shall notify the Owner that the Work has stopped. However, if the request is made because a change in the Work materially changes the Contract Sum under (3) above, the Contractor may immediately stop only that portion of the Work affected by the change until reasonable evidence is provided. If the Work is stopped under this Section 2.2.2, the Contract Time shall be extended appropriately and the Contract Sum shall be increased by the amount of the Contractor's reasonable costs of shutdown, delay and start-up, plus interest as provided in the Contract Documents.

§ 2.2.3 After the Owner furnishes evidence of financial arrangements under this Section 2.2, the Owner shall not materially vary such financial arrangements without prior notice to the Contractor.

§ 2.2.4 Where the Owner has designated information furnished under this Section 2.2 as "confidential," the Contractor shall keep the information confidential and shall not disclose it to any other person. However, the Contractor may disclose "confidential" information, after seven (7) days' notice to the Owner, where disclosure is required by law, including a subpoena or other form of compulsory legal process issued by a court or governmental entity, or by court or arbitrator(s) order. The Contractor may also disclose "confidential" information to its employees, consultants, sureties, Subcontractors and their employees, Sub-subcontractors, and others who need to know the content of such information solely and exclusively for the Project and who agree to maintain the confidentiality of such information.

§ 2.3 Information and Services Required of the Owner

§ 2.3.1 Except for permits and fees that are the responsibility of the Contractor under the Contract Documents, including those required under Section 3.7.1, the Owner shall secure and pay for necessary approvals, easements, assessments and charges required for construction, use or occupancy of permanent structures or for permanent changes in existing facilities.

§ 2.3.2 The Owner shall retain an architect lawfully licensed to practice architecture, or an entity lawfully practicing architecture, in the jurisdiction where the Project is located. That person or entity is identified as the Architect in the Agreement and is referred to throughout the Contract Documents as if singular in number.

§ 2.3.3 If the employment of the Architect terminates, the Owner shall employ a successor to whom the Contractor has no reasonable objection and whose status under the Contract Documents shall be that of the Architect.

§ 2.3.4 The Owner shall furnish surveys describing physical characteristics, legal limitations and utility locations for the site of the Project, and a legal description of the site. The Contractor shall be entitled to rely on the accuracy of information furnished by the Owner but shall exercise proper precautions relating to the safe performance of the Work.

§ 2.3.5 The Owner shall furnish information or services required of the Owner by the Contract Documents with reasonable promptness. The Owner shall also furnish any other information or services under the Owner's control and relevant to the Contractor's performance of the Work with reasonable promptness after receiving the Contractor's written request for such information or services.

§ 2.3.6 Unless otherwise provided in the Contract Documents, the Owner shall furnish to the Contractor one copy of the Contract Documents for purposes of making reproductions pursuant to Section 1.5.2.

§ 2.4 Owner's Right to Stop the Work

If the Contractor fails to correct Work that is not in accordance with the requirements of the Contract Documents as required by Section 12.2 or repeatedly fails to carry out Work in accordance with the Contract Documents, the Owner may issue a written order to the Contractor to stop the Work, or any portion thereof, until the cause for such order has been eliminated; however, the right of the Owner to stop the Work shall not give rise to a duty on the part of the Owner to exercise this right for the benefit of the Contractor or any other person or entity, except to the extent required by Section 6.1.3.

§ 2.5 Owner's Right to Carry Out the Work

If the Contractor defaults or neglects to carry out the Work in accordance with the Contract Documents and fails within a ten-day period after receipt of notice from the Owner to commence and continue correction of such default or neglect with diligence and promptness, the Owner may, without prejudice to other remedies the Owner may have, correct such default or neglect. Such action by the Owner and amounts charged to the Contractor are both subject to prior approval of the Architect and the Architect may, pursuant to Section 9.5.1, withhold or nullify a Certificate for Payment in whole or in part, to the extent reasonably necessary to reimburse the Owner for the reasonable cost of correcting such deficiencies, including Owner's expenses and compensation for the Architect's additional services made necessary by such default, neglect, or failure. If current and future payments are not sufficient to cover such amounts, the Contractor shall pay the difference to the Owner. If the Contractor disagrees with the actions of the Owner or the Architect, or the amounts claimed as costs to the Owner, the Contractor may file a Claim pursuant to Article 15.

ARTICLE 3 CONTRACTOR

§ 3.1 General

§ 3.1.1 The Contractor is the person or entity identified as such in the Agreement and is referred to throughout the Contract Documents as if singular in number. The Contractor shall be lawfully licensed, if required in the jurisdiction where the Project is located. The Contractor shall designate in writing a representative who shall have express authority to bind the Contractor with respect to all matters under this Contract. The term "Contractor" means the Contractor or the Contractor's authorized representative.

§ 3.1.2 The Contractor shall perform the Work in accordance with the Contract Documents.

§ 3.1.3 The Contractor shall not be relieved of its obligations to perform the Work in accordance with the Contract Documents either by activities or duties of the Architect in the Architect's administration of the Contract, or by tests, inspections or approvals required or performed by persons or entities other than the Contractor.

§ 3.2 Review of Contract Documents and Field Conditions by Contractor

§ 3.2.1 Execution of the Contract by the Contractor is a representation that the Contractor has visited the site, become generally familiar with local conditions under which the Work is to be performed, and correlated personal observations with requirements of the Contract Documents.

§ 3.2.2 Because the Contract Documents are complementary, the Contractor shall, before starting each portion of the Work, carefully study and compare the various Contract Documents relative to that portion of the Work, as well as the information furnished by the Owner pursuant to Section 2.3.4, shall take field measurements of any existing conditions related to that portion of the Work, and shall observe any conditions at the site affecting it. These obligations are for the purpose of facilitating coordination and construction by the Contractor and are not for the purpose of discovering errors, omissions, or inconsistencies in the Contract Documents; however, the Contractor shall promptly report to the Architect any errors, inconsistencies or omissions discovered by or made known to the Contractor as a request for information in such form as the Architect may require. It is recognized that the Contractor's review is made in the Contractor's capacity as a contractor and not as a licensed design professional, unless otherwise specifically provided in the Contract Documents.

§ 3.2.3 The Contractor is not required to ascertain that the Contract Documents are in accordance with applicable laws, statutes, ordinances, codes, rules and regulations, or lawful orders of public authorities, but the Contractor shall promptly report to the Architect any nonconformity discovered by or made known to the Contractor as a request for information in such form as the Architect may require.

§ 3.2.4 If the Contractor believes that additional cost or time is involved because of clarifications or instructions the Architect issues in response to the Contractor's notices or requests for information pursuant to Sections 3.2.2 or 3.2.3, the Contractor shall submit Claims as provided in Article 15. If the Contractor fails to perform the obligations of Sections 3.2.2 or 3.2.3, the Contractor shall pay such costs and damages to the Owner, subject to Section 15.1.7, as would have been avoided if the Contractor had performed such obligations. If the Contractor performs those obligations, the Contractor shall not be liable to the Owner or Architect for damages resulting from errors, inconsistencies or omissions in the Contract Documents, for differences between field measurements or conditions and the Contract Documents, or for nonconformities of the Contract Documents to applicable laws, statutes, ordinances, codes, rules and regulations, and lawful orders of public authorities.

§ 3.3 Supervision and Construction Procedures

§ 3.3.1 The Contractor shall supervise and direct the Work, using the Contractor's best skill and attention. The Contractor shall be solely responsible for, and have control over, construction means, methods, techniques, sequences, and procedures, and for coordinating all portions of the Work under the Contract. If the Contract Documents give specific instructions concerning construction means, methods, techniques, sequences, or procedures, the Contractor shall evaluate the jobsite safety thereof and shall be solely responsible for the jobsite safety of such means, methods, techniques, sequences, or procedures. If the Contractor determines that such means, methods, techniques, sequences or procedures may not be safe, the Contractor shall give timely notice to the Owner and Architect, and shall propose alternative means, methods, techniques, sequences, or procedures. The Architect shall evaluate the proposed alternative solely for conformance with the design intent for the completed construction. Unless the Architect objects to the Contractor's proposed alternative, the Contractor shall perform the Work using its alternative means, methods, techniques, sequences, or procedures.

§ 3.3.2 The Contractor shall be responsible to the Owner for acts and omissions of the Contractor's employees, Subcontractors and their agents and employees, and other persons or entities performing portions of the Work for, or on behalf of, the Contractor or any of its Subcontractors.

§ 3.3.3 The Contractor shall be responsible for inspection of portions of Work already performed to determine that such portions are in proper condition to receive subsequent Work.

§ 3.4 Labor and Materials

§ 3.4.1 Unless otherwise provided in the Contract Documents, the Contractor shall provide and pay for labor, materials, equipment, tools, construction equipment and machinery, water, heat, utilities, transportation, and other facilities and services necessary for proper execution and completion of the Work, whether temporary or permanent and whether or not incorporated or to be incorporated in the Work.

§ 3.4.2 Except in the case of minor changes in the Work approved by the Architect in accordance with Section 3.12.8 or ordered by the Architect in accordance with Section 7.4, the Contractor may make substitutions only with the consent of the Owner, after evaluation by the Architect and in accordance with a Change Order or Construction Change Directive.

§ 3.4.3 The Contractor shall enforce strict discipline and good order among the Contractor's employees and other persons carrying out the Work. The Contractor shall not permit employment of unfit persons or persons not properly skilled in tasks assigned to them.

§ 3.5 Warranty

§ 3.5.1 The Contractor warrants to the Owner and Architect that materials and equipment furnished under the Contract will be of good quality and new unless the Contract Documents require or permit otherwise. The Contractor further warrants that the Work will conform to the requirements of the Contract Documents and will be free from defects, except for those inherent in the quality of the Work the Contract Documents require or permit. Work, materials, or equipment not conforming to these requirements may be considered defective. The Contractor's warranty excludes remedy for damage or defect caused by abuse, alterations to the Work not executed by the Contractor, improper or insufficient maintenance, improper operation, or normal wear and tear and normal usage. If required by the Architect, the Contractor shall furnish satisfactory evidence as to the kind and quality of materials and equipment.

§ 3.5.2 All material, equipment, or other special warranties required by the Contract Documents shall be issued in the name of the Owner, or shall be transferable to the Owner, and shall commence in accordance with Section 9.8.4.

§ 3.6 Taxes

The Contractor shall pay sales, consumer, use and similar taxes for the Work provided by the Contractor that are legally enacted when bids are received or negotiations concluded, whether or not yet effective or merely scheduled to go into effect.

§ 3.7 Permits, Fees, Notices and Compliance with Laws

§ 3.7.1 Unless otherwise provided in the Contract Documents, the Contractor shall secure and pay for the building permit as well as for other permits, fees, licenses, and inspections by government agencies necessary for proper execution and completion of the Work that are customarily secured after execution of the Contract and legally required at the time bids are received or negotiations concluded.

§ 3.7.2 The Contractor shall comply with and give notices required by applicable laws, statutes, ordinances, codes, rules and regulations, and lawful orders of public authorities applicable to performance of the Work.

§ 3.7.3 If the Contractor performs Work knowing it to be contrary to applicable laws, statutes, ordinances, codes, rules and regulations, or lawful orders of public authorities, the Contractor shall assume appropriate responsibility for such Work and shall bear the costs attributable to correction.

§ 3.7.4 Concealed or Unknown Conditions

If the Contractor encounters conditions at the site that are (1) subsurface or otherwise concealed physical conditions that differ materially from those indicated in the Contract Documents or (2) unknown physical conditions of an unusual nature that differ materially from those ordinarily found to exist and generally recognized as inherent in construction activities of the character provided for in the Contract Documents, the Contractor shall promptly provide notice to the Owner and the Architect before conditions are disturbed and in no event later than 14 days after first observance of the conditions. The Architect will promptly investigate such conditions and, if the Architect determines that they differ materially and cause an increase or decrease in the Contractor's cost of, or time required for, performance of any part of the Work, will recommend that an equitable adjustment be made in the Contract Sum or Contract Time, or both. If the Architect determines that the conditions at the site are not materially different from those indicated in the Contract Documents and that no change in the terms of the Contract is justified, the Architect shall promptly notify the Owner and Contractor, stating the reasons. If either party disputes the Architect's determination or recommendation, that party may submit a Claim as provided in Article 15.

§ 3.7.5 If, in the course of the Work, the Contractor encounters human remains or recognizes the existence of burial markers, archaeological sites or wetlands not indicated in the Contract Documents, the Contractor shall immediately suspend any operations that would affect them and shall notify the Owner and Architect. Upon receipt of such notice, the Owner shall promptly take any action necessary to obtain governmental authorization required to resume the operations. The Contractor shall continue to suspend such operations until otherwise instructed by the Owner but shall continue with all other operations that do not affect those remains or features. Requests for adjustments in the Contract Sum and Contract Time arising from the existence of such remains or features may be made as provided in Article 15.

§ 3.8 Allowances

§ 3.8.1 The Contractor shall include in the Contract Sum all allowances stated in the Contract Documents. Items covered by allowances shall be supplied for such amounts and by such persons or entities as the Owner may direct, but the Contractor shall not be required to employ persons or entities to whom the Contractor has reasonable objection.

§ 3.8.2 Unless otherwise provided in the Contract Documents,

- .1 allowances shall cover the cost to the Contractor of materials and equipment delivered at the site and all required taxes, less applicable trade discounts;
- .2 Contractor's costs for unloading and handling at the site, labor, installation costs, overhead, profit, and other expenses contemplated for stated allowance amounts shall be included in the Contract Sum but not in the allowances; and
- .3 whenever costs are more than or less than allowances, the Contract Sum shall be adjusted accordingly by Change Order. The amount of the Change Order shall reflect (1) the difference between actual costs and the allowances under Section 3.8.2.1 and (2) changes in Contractor's costs under Section 3.8.2.2.

§ 3.8.3 Materials and equipment under an allowance shall be selected by the Owner with reasonable promptness.

§ 3.9 Superintendent

§ 3.9.1 The Contractor shall employ a competent superintendent and necessary assistants who shall be in attendance at the Project site during performance of the Work. The superintendent shall represent the Contractor, and communications given to the superintendent shall be as binding as if given to the Contractor.

§ 3.9.2 The Contractor, as soon as practicable after award of the Contract, shall notify the Owner and Architect of the name and qualifications of a proposed superintendent. Within 14 days of receipt of the information, the Architect may notify the Contractor, stating whether the Owner or the Architect (1) has reasonable objection to the proposed superintendent or (2) requires additional time for review. Failure of the Architect to provide notice within the 14-day period shall constitute notice of no reasonable objection.

§ 3.9.3 The Contractor shall not employ a proposed superintendent to whom the Owner or Architect has made reasonable and timely objection. The Contractor shall not change the superintendent without the Owner's consent, which shall not unreasonably be withheld or delayed.

§ 3.10 Contractor's Construction and Submittal Schedules

§ 3.10.1 The Contractor, promptly after being awarded the Contract, shall submit for the Owner's and Architect's information a Contractor's construction schedule for the Work. The schedule shall contain detail appropriate for the Project, including (1) the date of commencement of the Work, interim schedule milestone dates, and the date of Substantial Completion; (2) an apportionment of the Work by construction activity; and (3) the time required for completion of each portion of the Work. The schedule shall provide for the orderly progression of the Work to completion and shall not exceed time limits current under the Contract Documents. The schedule shall be revised at appropriate intervals as required by the conditions of the Work and Project.

§ 3.10.2 The Contractor, promptly after being awarded the Contract and thereafter as necessary to maintain a current submittal schedule, shall submit a submittal schedule for the Architect's approval. The Architect's approval shall not be unreasonably delayed or withheld. The submittal schedule shall (1) be coordinated with the Contractor's construction schedule, and (2) allow the Architect reasonable time to review submittals. If the Contractor fails to submit a submittal schedule, or fails to provide submittals in accordance with the approved submittal schedule, the Contractor shall not be entitled to any increase in Contract Sum or extension of Contract Time based on the time required for review of submittals.

§ 3.10.3 The Contractor shall perform the Work in general accordance with the most recent schedules submitted to the Owner and Architect.

§ 3.11 Documents and Samples at the Site

The Contractor shall make available, at the Project site, the Contract Documents, including Change Orders, Construction Change Directives, and other Modifications, in good order and marked currently to indicate field changes and selections made during construction, and the approved Shop Drawings, Product Data, Samples, and similar required submittals. These shall be in electronic form or paper copy, available to the Architect and Owner, and

delivered to the Architect for submittal to the Owner upon completion of the Work as a record of the Work as constructed.

§ 3.12 Shop Drawings, Product Data and Samples

§ 3.12.1 Shop Drawings are drawings, diagrams, schedules, and other data specially prepared for the Work by the Contractor or a Subcontractor, Sub-subcontractor, manufacturer, supplier, or distributor to illustrate some portion of the Work.

§ 3.12.2 Product Data are illustrations, standard schedules, performance charts, instructions, brochures, diagrams, and other information furnished by the Contractor to illustrate materials or equipment for some portion of the Work.

§ 3.12.3 Samples are physical examples that illustrate materials, equipment, or workmanship, and establish standards by which the Work will be judged.

§ 3.12.4 Shop Drawings, Product Data, Samples, and similar submittals are not Contract Documents. Their purpose is to demonstrate how the Contractor proposes to conform to the information given and the design concept expressed in the Contract Documents for those portions of the Work for which the Contract Documents require submittals. Review by the Architect is subject to the limitations of Section 4.2.7. Informational submittals upon which the Architect is not expected to take responsive action may be so identified in the Contract Documents. Submittals that are not required by the Contract Documents may be returned by the Architect without action.

§ 3.12.5 The Contractor shall review for compliance with the Contract Documents, approve, and submit to the Architect, Shop Drawings, Product Data, Samples, and similar submittals required by the Contract Documents, in accordance with the submittal schedule approved by the Architect or, in the absence of an approved submittal schedule, with reasonable promptness and in such sequence as to cause no delay in the Work or in the activities of the Owner or of Separate Contractors.

§ 3.12.6 By submitting Shop Drawings, Product Data, Samples, and similar submittals, the Contractor represents to the Owner and Architect that the Contractor has (1) reviewed and approved them, (2) determined and verified materials, field measurements and field construction criteria related thereto, or will do so, and (3) checked and coordinated the information contained within such submittals with the requirements of the Work and of the Contract Documents.

§ 3.12.7 The Contractor shall perform no portion of the Work for which the Contract Documents require submittal and review of Shop Drawings, Product Data, Samples, or similar submittals, until the respective submittal has been approved by the Architect.

§ 3.12.8 The Work shall be in accordance with approved submittals except that the Contractor shall not be relieved of responsibility for deviations from the requirements of the Contract Documents by the Architect's approval of Shop Drawings, Product Data, Samples, or similar submittals, unless the Contractor has specifically notified the Architect of such deviation at the time of submittal and (1) the Architect has given written approval to the specific deviation as a minor change in the Work, or (2) a Change Order or Construction Change Directive has been issued authorizing the deviation. The Contractor shall not be relieved of responsibility for errors or omissions in Shop Drawings, Product Data, Samples, or similar submittals, by the Architect's approval thereof.

§ 3.12.9 The Contractor shall direct specific attention, in writing or on resubmitted Shop Drawings, Product Data, Samples, or similar submittals, to revisions other than those requested by the Architect on previous submittals. In the absence of such notice, the Architect's approval of a resubmission shall not apply to such revisions.

§ 3.12.10 The Contractor shall not be required to provide professional services that constitute the practice of architecture or engineering unless such services are specifically required by the Contract Documents for a portion of the Work or unless the Contractor needs to provide such services in order to carry out the Contractor's responsibilities for construction means, methods, techniques, sequences, and procedures. The Contractor shall not be required to provide professional services in violation of applicable law.

§ 3.12.10.1 If professional design services or certifications by a design professional related to systems, materials, or equipment are specifically required of the Contractor by the Contract Documents, the Owner and the Architect will specify all performance and design criteria that such services must satisfy. The Contractor shall be entitled to rely

Init.

/

upon the adequacy and accuracy of the performance and design criteria provided in the Contract Documents. The Contractor shall cause such services or certifications to be provided by an appropriately licensed design professional, whose signature and seal shall appear on all drawings, calculations, specifications, certifications, Shop Drawings, and other submittals prepared by such professional. Shop Drawings, and other submittals related to the Work, designed or certified by such professional, if prepared by others, shall bear such professional's written approval when submitted to the Architect. The Owner and the Architect shall be entitled to rely upon the adequacy and accuracy of the services, certifications, and approvals performed or provided by such design professionals, provided the Owner and Architect have specified to the Contractor the performance and design criteria that such services must satisfy. Pursuant to this Section 3.12.10, the Architect will review and approve or take other appropriate action on submittals only for the limited purpose of checking for conformance with information given and the design concept expressed in the Contract Documents.

§ 3.12.10.2 If the Contract Documents require the Contractor's design professional to certify that the Work has been performed in accordance with the design criteria, the Contractor shall furnish such certifications to the Architect at the time and in the form specified by the Architect.

§ 3.13 Use of Site

The Contractor shall confine operations at the site to areas permitted by applicable laws, statutes, ordinances, codes, rules and regulations, lawful orders of public authorities, and the Contract Documents and shall not unreasonably encumber the site with materials or equipment.

§ 3.14 Cutting and Patching

§ 3.14.1 The Contractor shall be responsible for cutting, fitting, or patching required to complete the Work or to make its parts fit together properly. All areas requiring cutting, fitting, or patching shall be restored to the condition existing prior to the cutting, fitting, or patching, unless otherwise required by the Contract Documents.

§ 3.14.2 The Contractor shall not damage or endanger a portion of the Work or fully or partially completed construction of the Owner or Separate Contractors by cutting, patching, or otherwise altering such construction, or by excavation. The Contractor shall not cut or otherwise alter construction by the Owner or a Separate Contractor except with written consent of the Owner and of the Separate Contractor. Consent shall not be unreasonably withheld. The Contractor shall not unreasonably withhold, from the Owner or a Separate Contractor, its consent to cutting or otherwise altering the Work.

§ 3.15 Cleaning Up

§ 3.15.1 The Contractor shall keep the premises and surrounding area free from accumulation of waste materials and rubbish caused by operations under the Contract. At completion of the Work, the Contractor shall remove waste materials, rubbish, the Contractor's tools, construction equipment, machinery, and surplus materials from and about the Project.

§ 3.15.2 If the Contractor fails to clean up as provided in the Contract Documents, the Owner may do so and the Owner shall be entitled to reimbursement from the Contractor.

§ 3.16 Access to Work

The Contractor shall provide the Owner and Architect with access to the Work in preparation and progress wherever located.

§ 3.17 Royalties, Patents and Copyrights

The Contractor shall pay all royalties and license fees. The Contractor shall defend suits or claims for infringement of copyrights and patent rights and shall hold the Owner and Architect harmless from loss on account thereof, but shall not be responsible for defense or loss when a particular design, process, or product of a particular manufacturer or manufacturers is required by the Contract Documents, or where the copyright violations are contained in Drawings, Specifications, or other documents prepared by the Owner or Architect. However, if an infringement of a copyright or patent is discovered by, or made known to, the Contractor, the Contractor shall be responsible for the loss unless the information is promptly furnished to the Architect.

§ 3.18 Indemnification

§ 3.18.1 To the fullest extent permitted by law, the Contractor shall indemnify and hold harmless the Owner, Architect, Architect's consultants, and agents and employees of any of them from and against claims, damages, losses, and expenses, including but not limited to attorneys' fees, arising out of or resulting from performance of the Work, provided that such claim, damage, loss, or expense is attributable to bodily injury, sickness, disease or death, or to injury to or destruction of tangible property (other than the Work itself), but only to the extent caused by the negligent acts or omissions of the Contractor, a Subcontractor, anyone directly or indirectly employed by them, or anyone for whose acts they may be liable, regardless of whether or not such claim, damage, loss, or expense is caused in part by a party indemnified hereunder. Such obligation shall not be construed to negate, abridge, or reduce other rights or obligations of indemnity that would otherwise exist as to a party or person described in this Section 3.18.

§ 3.18.2 In claims against any person or entity indemnified under this Section 3.18 by an employee of the Contractor, a Subcontractor, anyone directly or indirectly employed by them, or anyone for whose acts they may be liable, the indemnification obligation under Section 3.18.1 shall not be limited by a limitation on amount or type of damages, compensation, or benefits payable by or for the Contractor or a Subcontractor under workers' compensation acts, disability benefit acts, or other employee benefit acts.

ARTICLE 4 ARCHITECT

§ 4.1 General

§ 4.1.1 The Architect is the person or entity retained by the Owner pursuant to Section 2.3.2 and identified as such in the Agreement.

§ 4.1.2 Duties, responsibilities, and limitations of authority of the Architect as set forth in the Contract Documents shall not be restricted, modified, or extended without written consent of the Owner, Contractor, and Architect. Consent shall not be unreasonably withheld.

§ 4.2 Administration of the Contract

§ 4.2.1 The Architect will provide administration of the Contract as described in the Contract Documents and will be an Owner's representative during construction until the date the Architect issues the final Certificate for Payment. The Architect will have authority to act on behalf of the Owner only to the extent provided in the Contract Documents.

§ 4.2.2 The Architect will visit the site at intervals appropriate to the stage of construction, or as otherwise agreed with the Owner, to become generally familiar with the progress and quality of the portion of the Work completed, and to determine in general if the Work observed is being performed in a manner indicating that the Work, when fully completed, will be in accordance with the Contract Documents. However, the Architect will not be required to make exhaustive or continuous on-site inspections to check the quality or quantity of the Work. The Architect will not have control over, charge of, or responsibility for the construction means, methods, techniques, sequences or procedures, or for the safety precautions and programs in connection with the Work, since these are solely the Contractor's rights and responsibilities under the Contract Documents.

§ 4.2.3 On the basis of the site visits, the Architect will keep the Owner reasonably informed about the progress and quality of the portion of the Work completed, and promptly report to the Owner (1) known deviations from the Contract Documents, (2) known deviations from the most recent construction schedule submitted by the Contractor, and (3) defects and deficiencies observed in the Work. The Architect will not be responsible for the Contractor's failure to perform the Work in accordance with the requirements of the Contract Documents. The Architect will not have control over or charge of, and will not be responsible for acts or omissions of, the Contractor, Subcontractors, or their agents or employees, or any other persons or entities performing portions of the Work.

§ 4.2.4 Communications

The Owner and Contractor shall include the Architect in all communications that relate to or affect the Architect's services or professional responsibilities. The Owner shall promptly notify the Architect of the substance of any direct communications between the Owner and the Contractor otherwise relating to the Project. Communications by and with the Architect's consultants shall be through the Architect. Communications by and with Subcontractors and suppliers shall be through the Contractor. Communications by and with Separate Contractors shall be through the Owner. The Contract Documents may specify other communication protocols.

§ 4.2.5 Based on the Architect's evaluations of the Contractor's Applications for Payment, the Architect will review and certify the amounts due the Contractor and will issue Certificates for Payment in such amounts.

§ 4.2.6 The Architect has authority to reject Work that does not conform to the Contract Documents. Whenever the Architect considers it necessary or advisable, the Architect will have authority to require inspection or testing of the Work in accordance with Sections 13.4.2 and 13.4.3, whether or not the Work is fabricated, installed or completed. However, neither this authority of the Architect nor a decision made in good faith either to exercise or not to exercise such authority shall give rise to a duty or responsibility of the Architect to the Contractor, Subcontractors, suppliers, their agents or employees, or other persons or entities performing portions of the Work.

§ 4.2.7 The Architect will review and approve, or take other appropriate action upon, the Contractor's submittals such as Shop Drawings, Product Data, and Samples, but only for the limited purpose of checking for conformance with information given and the design concept expressed in the Contract Documents. The Architect's action will be taken in accordance with the submittal schedule approved by the Architect or, in the absence of an approved submittal schedule, with reasonable promptness while allowing sufficient time in the Architect's professional judgment to permit adequate review. Review of such submittals is not conducted for the purpose of determining the accuracy and completeness of other details such as dimensions and quantities, or for substantiating instructions for installation or performance of equipment or systems, all of which remain the responsibility of the Contractor as required by the Contract Documents. The Architect's review of the Contractor's submittals shall not relieve the Contractor of the obligations under Sections 3.3, 3.5, and 3.12. The Architect's review shall not constitute approval of safety precautions or of any construction means, methods, techniques, sequences, or procedures. The Architect's approval of a specific item shall not indicate approval of an assembly of which the item is a component.

§ 4.2.8 The Architect will prepare Change Orders and Construction Change Directives, and may order minor changes in the Work as provided in Section 7.4. The Architect will investigate and make determinations and recommendations regarding concealed and unknown conditions as provided in Section 3.7.4.

§ 4.2.9 The Architect will conduct inspections to determine the date or dates of Substantial Completion and the date of final completion; issue Certificates of Substantial Completion pursuant to Section 9.8; receive and forward to the Owner, for the Owner's review and records, written warranties and related documents required by the Contract and assembled by the Contractor pursuant to Section 9.10; and issue a final Certificate for Payment pursuant to Section 9.10.

§ 4.2.10 If the Owner and Architect agree, the Architect will provide one or more Project representatives to assist in carrying out the Architect's responsibilities at the site. The Owner shall notify the Contractor of any change in the duties, responsibilities and limitations of authority of the Project representatives.

§ 4.2.11 The Architect will interpret and decide matters concerning performance under, and requirements of, the Contract Documents on written request of either the Owner or Contractor. The Architect's response to such requests will be made in writing within any time limits agreed upon or otherwise with reasonable promptness.

§ 4.2.12 Interpretations and decisions of the Architect will be consistent with the intent of, and reasonably inferable from, the Contract Documents and will be in writing or in the form of drawings. When making such interpretations and decisions, the Architect will endeavor to secure faithful performance by both Owner and Contractor, will not show partiality to either, and will not be liable for results of interpretations or decisions rendered in good faith.

§ 4.2.13 The Architect's decisions on matters relating to aesthetic effect will be final if consistent with the intent expressed in the Contract Documents.

§ 4.2.14 The Architect will review and respond to requests for information about the Contract Documents. The Architect's response to such requests will be made in writing within any time limits agreed upon or otherwise with reasonable promptness. If appropriate, the Architect will prepare and issue supplemental Drawings and Specifications in response to the requests for information.

ARTICLE 5 SUBCONTRACTORS

§ 5.1 Definitions

§ 5.1.1 A Subcontractor is a person or entity who has a direct contract with the Contractor to perform a portion of the Work at the site. The term "Subcontractor" is referred to throughout the Contract Documents as if singular in number and means a Subcontractor or an authorized representative of the Subcontractor. The term "Subcontractor" does not include a Separate Contractor or the subcontractors of a Separate Contractor.

§ 5.1.2 A Sub-subcontractor is a person or entity who has a direct or indirect contract with a Subcontractor to perform a portion of the Work at the site. The term "Sub-subcontractor" is referred to throughout the Contract Documents as if singular in number and means a Sub-subcontractor or an authorized representative of the Sub-subcontractor.

§ 5.2 Award of Subcontracts and Other Contracts for Portions of the Work

§ 5.2.1 Unless otherwise stated in the Contract Documents, the Contractor, as soon as practicable after award of the Contract, shall notify the Owner and Architect of the persons or entities proposed for each principal portion of the Work, including those who are to furnish materials or equipment fabricated to a special design. Within 14 days of receipt of the information, the Architect may notify the Contractor whether the Owner or the Architect (1) has reasonable objection to any such proposed person or entity or (2) requires additional time for review. Failure of the Architect to provide notice within the 14-day period shall constitute notice of no reasonable objection.

§ 5.2.2 The Contractor shall not contract with a proposed person or entity to whom the Owner or Architect has made reasonable and timely objection. The Contractor shall not be required to contract with anyone to whom the Contractor has made reasonable objection.

§ 5.2.3 If the Owner or Architect has reasonable objection to a person or entity proposed by the Contractor, the Contractor shall propose another to whom the Owner or Architect has no reasonable objection. If the proposed but rejected Subcontractor was reasonably capable of performing the Work, the Contract Sum and Contract Time shall be increased or decreased by the difference, if any, occasioned by such change, and an appropriate Change Order shall be issued before commencement of the substitute Subcontractor's Work. However, no increase in the Contract Sum or Contract Time shall be allowed for such change unless the Contractor has acted promptly and responsively in submitting names as required.

§ 5.2.4 The Contractor shall not substitute a Subcontractor, person, or entity for one previously selected if the Owner or Architect makes reasonable objection to such substitution.

§ 5.3 Subcontractual Relations

By appropriate written agreement, the Contractor shall require each Subcontractor, to the extent of the Work to be performed by the Subcontractor, to be bound to the Contractor by terms of the Contract Documents, and to assume toward the Contractor all the obligations and responsibilities, including the responsibility for safety of the Subcontractor's Work that the Contractor, by these Contract Documents, assumes toward the Owner and Architect. Each subcontract agreement shall preserve and protect the rights of the Owner and Architect under the Contract Documents with respect to the Work to be performed by the Subcontractor so that subcontracting thereof will not prejudice such rights, and shall allow to the Subcontractor, unless specifically provided otherwise in the subcontract agreement, the benefit of all rights, remedies, and redress against the Contractor that the Contractor, by the Contract Documents, has against the Owner. Where appropriate, the Contractor shall require each Subcontractor to enter into similar agreements with Sub-subcontractors. The Contractor shall make available to each proposed Subcontractor, prior to the execution of the subcontract agreement, copies of the Contract Documents to which the Subcontractor will be bound, and, upon written request of the Subcontractor, identify to the Subcontractor terms and conditions of the proposed subcontract agreement that may be at variance with the Contract Documents. Subcontractors will similarly make copies of applicable portions of such documents available to their respective proposed Sub-subcontractors.

§ 5.4 Contingent Assignment of Subcontracts

§ 5.4.1 Each subcontract agreement for a portion of the Work is assigned by the Contractor to the Owner, provided that

- .1 assignment is effective only after termination of the Contract by the Owner for cause pursuant to Section 14.2 and only for those subcontract agreements that the Owner accepts by notifying the Subcontractor and Contractor; and
- .2 assignment is subject to the prior rights of the surety, if any, obligated under bond relating to the Contract.

When the Owner accepts the assignment of a subcontract agreement, the Owner assumes the Contractor's rights and obligations under the subcontract.

§ 5.4.2 Upon such assignment, if the Work has been suspended for more than 30 days, the Subcontractor's compensation shall be equitably adjusted for increases in cost resulting from the suspension.

§ 5.4.3 Upon assignment to the Owner under this Section 5.4, the Owner may further assign the subcontract to a successor contractor or other entity. If the Owner assigns the subcontract to a successor contractor or other entity, the Owner shall nevertheless remain legally responsible for all of the successor contractor's obligations under the subcontract.

ARTICLE 6 CONSTRUCTION BY OWNER OR BY SEPARATE CONTRACTORS

§ 6.1 Owner's Right to Perform Construction and to Award Separate Contracts

§ 6.1.1 The term "Separate Contractor(s)" shall mean other contractors retained by the Owner under separate agreements. The Owner reserves the right to perform construction or operations related to the Project with the Owner's own forces, and with Separate Contractors retained under Conditions of the Contract substantially similar to those of this Contract, including those provisions of the Conditions of the Contract related to insurance and waiver of subrogation.

§ 6.1.2 When separate contracts are awarded for different portions of the Project or other construction or operations on the site, the term "Contractor" in the Contract Documents in each case shall mean the Contractor who executes each separate Owner-Contractor Agreement.

§ 6.1.3 The Owner shall provide for coordination of the activities of the Owner's own forces and of each Separate Contractor with the Work of the Contractor, who shall cooperate with them. The Contractor shall participate with any Separate Contractors and the Owner in reviewing their construction schedules. The Contractor shall make any revisions to its construction schedule deemed necessary after a joint review and mutual agreement. The construction schedules shall then constitute the schedules to be used by the Contractor, Separate Contractors, and the Owner until subsequently revised.

§ 6.1.4 Unless otherwise provided in the Contract Documents, when the Owner performs construction or operations related to the Project with the Owner's own forces or with Separate Contractors, the Owner or its Separate Contractors shall have the same obligations and rights that the Contractor has under the Conditions of the Contract, including, without excluding others, those stated in Article 3, this Article 6, and Articles 10, 11, and 12.

§ 6.2 Mutual Responsibility

§ 6.2.1 The Contractor shall afford the Owner and Separate Contractors reasonable opportunity for introduction and storage of their materials and equipment and performance of their activities, and shall connect and coordinate the Contractor's construction and operations with theirs as required by the Contract Documents.

§ 6.2.2 If part of the Contractor's Work depends for proper execution or results upon construction or operations by the Owner or a Separate Contractor, the Contractor shall, prior to proceeding with that portion of the Work, promptly notify the Architect of apparent discrepancies or defects in the construction or operations by the Owner or Separate Contractor that would render it unsuitable for proper execution and results of the Contractor's Work. Failure of the Contractor to notify the Architect of apparent discrepancies or defects prior to proceeding with the Work shall constitute an acknowledgment that the Owner's or Separate Contractor's completed or partially completed construction is fit and proper to receive the Contractor's Work. The Contractor shall not be responsible for discrepancies or defects in the construction or operations by the Owner or Separate Contractor that are not apparent.

§ 6.2.3 The Contractor shall reimburse the Owner for costs the Owner incurs that are payable to a Separate Contractor because of the Contractor's delays, improperly timed activities or defective construction. The Owner shall be responsible to the Contractor for costs the Contractor incurs because of a Separate Contractor's delays, improperly timed activities, damage to the Work or defective construction.

§ 6.2.4 The Contractor shall promptly remedy damage that the Contractor wrongfully causes to completed or partially completed construction or to property of the Owner or Separate Contractor as provided in Section 10.2.5.

§ 6.2.5 The Owner and each Separate Contractor shall have the same responsibilities for cutting and patching as are described for the Contractor in Section 3.14.

§ 6.3 Owner's Right to Clean Up

If a dispute arises among the Contractor, Separate Contractors, and the Owner as to the responsibility under their respective contracts for maintaining the premises and surrounding area free from waste materials and rubbish, the Owner may clean up and the Architect will allocate the cost among those responsible.

ARTICLE 7 CHANGES IN THE WORK

§ 7.1 General

§ 7.1.1 Changes in the Work may be accomplished after execution of the Contract, and without invalidating the Contract, by Change Order, Construction Change Directive or order for a minor change in the Work, subject to the limitations stated in this Article 7 and elsewhere in the Contract Documents.

§ 7.1.2 A Change Order shall be based upon agreement among the Owner, Contractor, and Architect. A Construction Change Directive requires agreement by the Owner and Architect and may or may not be agreed to by the Contractor. An order for a minor change in the Work may be issued by the Architect alone.

§ 7.1.3 Changes in the Work shall be performed under applicable provisions of the Contract Documents. The Contractor shall proceed promptly with changes in the Work, unless otherwise provided in the Change Order, Construction Change Directive, or order for a minor change in the Work.

§ 7.2 Change Orders

§ 7.2.1 A Change Order is a written instrument prepared by the Architect and signed by the Owner, Contractor, and Architect stating their agreement upon all of the following:

- .1 The change in the Work;
- .2 The amount of the adjustment, if any, in the Contract Sum; and
- .3 The extent of the adjustment, if any, in the Contract Time.

§ 7.3 Construction Change Directives

§ 7.3.1 A Construction Change Directive is a written order prepared by the Architect and signed by the Owner and Architect, directing a change in the Work prior to agreement on adjustment, if any, in the Contract Sum or Contract Time, or both. The Owner may by Construction Change Directive, without invalidating the Contract, order changes in the Work within the general scope of the Contract consisting of additions, deletions, or other revisions, the Contract Sum and Contract Time being adjusted accordingly.

§ 7.3.2 A Construction Change Directive shall be used in the absence of total agreement on the terms of a Change Order.

§ 7.3.3 If the Construction Change Directive provides for an adjustment to the Contract Sum, the adjustment shall be based on one of the following methods:

- .1 Mutual acceptance of a lump sum properly itemized and supported by sufficient substantiating data to permit evaluation;
- .2 Unit prices stated in the Contract Documents or subsequently agreed upon;
- .3 Cost to be determined in a manner agreed upon by the parties and a mutually acceptable fixed or percentage fee; or
- .4 As provided in Section 7.3.4.

§ 7.3.4 If the Contractor does not respond promptly or disagrees with the method for adjustment in the Contract Sum, the Architect shall determine the adjustment on the basis of reasonable expenditures and savings of those performing the Work attributable to the change, including, in case of an increase in the Contract Sum, an amount for overhead and profit as set forth in the Agreement, or if no such amount is set forth in the Agreement, a reasonable amount. In such case, and also under Section 7.3.3.3, the Contractor shall keep and present, in such form as the Architect may prescribe, an itemized accounting together with appropriate supporting data. Unless otherwise provided in the Contract Documents, costs for the purposes of this Section 7.3.4 shall be limited to the following:

- .1 Costs of labor, including applicable payroll taxes, fringe benefits required by agreement or custom, workers' compensation insurance, and other employee costs approved by the Architect;
- .2 Costs of materials, supplies, and equipment, including cost of transportation, whether incorporated or consumed;
- .3 Rental costs of machinery and equipment, exclusive of hand tools, whether rented from the Contractor or others;
- .4 Costs of premiums for all bonds and insurance, permit fees, and sales, use, or similar taxes, directly related to the change; and
- .5 Costs of supervision and field office personnel directly attributable to the change.

§ 7.3.5 If the Contractor disagrees with the adjustment in the Contract Time, the Contractor may make a Claim in accordance with applicable provisions of Article 15.

§ 7.3.6 Upon receipt of a Construction Change Directive, the Contractor shall promptly proceed with the change in the Work involved and advise the Architect of the Contractor's agreement or disagreement with the method, if any, provided in the Construction Change Directive for determining the proposed adjustment in the Contract Sum or Contract Time.

§ 7.3.7 A Construction Change Directive signed by the Contractor indicates the Contractor's agreement therewith, including adjustment in Contract Sum and Contract Time or the method for determining them. Such agreement shall be effective immediately and shall be recorded as a Change Order.

§ 7.3.8 The amount of credit to be allowed by the Contractor to the Owner for a deletion or change that results in a net decrease in the Contract Sum shall be actual net cost as confirmed by the Architect. When both additions and credits covering related Work or substitutions are involved in a change, the allowance for overhead and profit shall be figured on the basis of net increase, if any, with respect to that change.

§ 7.3.9 Pending final determination of the total cost of a Construction Change Directive to the Owner, the Contractor may request payment for Work completed under the Construction Change Directive in Applications for Payment. The Architect will make an interim determination for purposes of monthly certification for payment for those costs and certify for payment the amount that the Architect determines, in the Architect's professional judgment, to be reasonably justified. The Architect's interim determination of cost shall adjust the Contract Sum on the same basis as a Change Order, subject to the right of either party to disagree and assert a Claim in accordance with Article 15.

§ 7.3.10 When the Owner and Contractor agree with a determination made by the Architect concerning the adjustments in the Contract Sum and Contract Time, or otherwise reach agreement upon the adjustments, such agreement shall be effective immediately and the Architect will prepare a Change Order. Change Orders may be issued for all or any part of a Construction Change Directive.

§ 7.4 Minor Changes in the Work

The Architect may order minor changes in the Work that are consistent with the intent of the Contract Documents and do not involve an adjustment in the Contract Sum or an extension of the Contract Time. The Architect's order for minor changes shall be in writing. If the Contractor believes that the proposed minor change in the Work will affect the Contract Sum or Contract Time, the Contractor shall notify the Architect and shall not proceed to implement the change in the Work. If the Contractor performs the Work set forth in the Architect's order for a minor change without prior notice to the Architect that such change will affect the Contract Sum or Contract Time, the Contractor waives any adjustment to the Contract Sum or extension of the Contract Time.

ARTICLE 8 TIME

§ 8.1 Definitions

§ 8.1.1 Unless otherwise provided, Contract Time is the period of time, including authorized adjustments, allotted in the Contract Documents for Substantial Completion of the Work.

§ 8.1.2 The date of commencement of the Work is the date established in the Agreement.

§ 8.1.3 The date of Substantial Completion is the date certified by the Architect in accordance with Section 9.8.

§ 8.1.4 The term "day" as used in the Contract Documents shall mean calendar day unless otherwise specifically defined.

§ 8.2 Progress and Completion

§ 8.2.1 Time limits stated in the Contract Documents are of the essence of the Contract. By executing the Agreement, the Contractor confirms that the Contract Time is a reasonable period for performing the Work.

§ 8.2.2 The Contractor shall not knowingly, except by agreement or instruction of the Owner in writing, commence the Work prior to the effective date of insurance required to be furnished by the Contractor and Owner.

§ 8.2.3 The Contractor shall proceed expeditiously with adequate forces and shall achieve Substantial Completion within the Contract Time.

§ 8.3 Delays and Extensions of Time

§ 8.3.1 If the Contractor is delayed at any time in the commencement or progress of the Work by (1) an act or neglect of the Owner or Architect, of an employee of either, or of a Separate Contractor; (2) by changes ordered in the Work; (3) by labor disputes, fire, unusual delay in deliveries, unavoidable casualties, adverse weather conditions documented in accordance with Section 15.1.6.2, or other causes beyond the Contractor's control; (4) by delay authorized by the Owner pending mediation and binding dispute resolution; or (5) by other causes that the Contractor asserts, and the Architect determines, justify delay, then the Contract Time shall be extended for such reasonable time as the Architect may determine.

§ 8.3.2 Claims relating to time shall be made in accordance with applicable provisions of Article 15.

§ 8.3.3 This Section 8.3 does not preclude recovery of damages for delay by either party under other provisions of the Contract Documents.

ARTICLE 9 PAYMENTS AND COMPLETION

§ 9.1 Contract Sum

§ 9.1.1 The Contract Sum is stated in the Agreement and, including authorized adjustments, is the total amount payable by the Owner to the Contractor for performance of the Work under the Contract Documents.

§ 9.1.2 If unit prices are stated in the Contract Documents or subsequently agreed upon, and if quantities originally contemplated are materially changed so that application of such unit prices to the actual quantities causes substantial inequity to the Owner or Contractor, the applicable unit prices shall be equitably adjusted.

§ 9.2 Schedule of Values

Where the Contract is based on a stipulated sum or Guaranteed Maximum Price, the Contractor shall submit a schedule of values to the Architect before the first Application for Payment, allocating the entire Contract Sum to the various portions of the Work. The schedule of values shall be prepared in the form, and supported by the data to substantiate its accuracy, required by the Architect. This schedule, unless objected to by the Architect, shall be used as a basis for reviewing the Contractor's Applications for Payment. Any changes to the schedule of values shall be submitted to the Architect and supported by such data to substantiate its accuracy as the Architect may require, and unless objected to by the Architect, shall be used as a basis for reviewing the Contractor's subsequent Applications for Payment.

§ 9.3 Applications for Payment

§ 9.3.1 At least ten days before the date established for each progress payment, the Contractor shall submit to the Architect an itemized Application for Payment prepared in accordance with the schedule of values, if required under Section 9.2, for completed portions of the Work. The application shall be notarized, if required, and supported by all data substantiating the Contractor's right to payment that the Owner or Architect require, such as copies of requisitions, and releases and waivers of liens from Subcontractors and suppliers, and shall reflect retainage if provided for in the Contract Documents.

§ 9.3.1.1 As provided in Section 7.3.9, such applications may include requests for payment on account of changes in the Work that have been properly authorized by Construction Change Directives, or by interim determinations of the Architect, but not yet included in Change Orders.

§ 9.3.1.2 Applications for Payment shall not include requests for payment for portions of the Work for which the Contractor does not intend to pay a Subcontractor or supplier, unless such Work has been performed by others whom the Contractor intends to pay.

§ 9.3.2 Unless otherwise provided in the Contract Documents, payments shall be made on account of materials and equipment delivered and suitably stored at the site for subsequent incorporation in the Work. If approved in advance by the Owner, payment may similarly be made for materials and equipment suitably stored off the site at a location agreed upon in writing. Payment for materials and equipment stored on or off the site shall be conditioned upon compliance by the Contractor with procedures satisfactory to the Owner to establish the Owner's title to such materials and equipment or otherwise protect the Owner's interest, and shall include the costs of applicable insurance, storage, and transportation to the site, for such materials and equipment stored off the site.

§ 9.3.3 The Contractor warrants that title to all Work covered by an Application for Payment will pass to the Owner no later than the time of payment. The Contractor further warrants that upon submittal of an Application for Payment all Work for which Certificates for Payment have been previously issued and payments received from the Owner shall, to the best of the Contractor's knowledge, information, and belief, be free and clear of liens, claims, security interests, or encumbrances, in favor of the Contractor, Subcontractors, suppliers, or other persons or entities that provided labor, materials, and equipment relating to the Work.

§ 9.4 Certificates for Payment

§ 9.4.1 The Architect will, within seven days after receipt of the Contractor's Application for Payment, either (1) issue to the Owner a Certificate for Payment in the full amount of the Application for Payment, with a copy to the Contractor; or (2) issue to the Owner a Certificate for Payment for such amount as the Architect determines is properly due, and notify the Contractor and Owner of the Architect's reasons for withholding certification in part as provided in Section 9.5.1; or (3) withhold certification of the entire Application for Payment, and notify the Contractor and Owner of the Architect's reason for withholding certification in whole as provided in Section 9.5.1.

§ 9.4.2 The issuance of a Certificate for Payment will constitute a representation by the Architect to the Owner, based on the Architect's evaluation of the Work and the data in the Application for Payment, that, to the best of the Architect's knowledge, information, and belief, the Work has progressed to the point indicated, the quality of the Work is in accordance with the Contract Documents, and that the Contractor is entitled to payment in the amount certified. The foregoing representations are subject to an evaluation of the Work for conformance with the Contract Documents upon Substantial Completion, to results of subsequent tests and inspections, to correction of minor deviations from the Contract Documents prior to completion, and to specific qualifications expressed by the Architect. However, the issuance of a Certificate for Payment will not be a representation that the Architect has (1) made exhaustive or continuous on-site inspections to check the quality or quantity of the Work; (2) reviewed construction means, methods, techniques, sequences, or procedures; (3) reviewed copies of requisitions received from Subcontractors and suppliers and other data requested by the Owner to substantiate the Contractor's right to payment; or (4) made examination to ascertain how or for what purpose the Contractor has used money previously paid on account of the Contract Sum.

§ 9.5 Decisions to Withhold Certification

§ 9.5.1 The Architect may withhold a Certificate for Payment in whole or in part, to the extent reasonably necessary to protect the Owner, if in the Architect's opinion the representations to the Owner required by Section 9.4.2 cannot be made. If the Architect is unable to certify payment in the amount of the Application, the Architect will notify the Contractor and Owner as provided in Section 9.4.1. If the Contractor and Architect cannot agree on a revised amount, the Architect will promptly issue a Certificate for Payment for the amount for which the Architect is able to make such representations to the Owner. The Architect may also withhold a Certificate for Payment or, because of subsequently discovered evidence, may nullify the whole or a part of a Certificate for Payment previously issued, to such extent as may be necessary in the Architect's opinion to protect the Owner from loss for which the Contractor is responsible, including loss resulting from acts and omissions described in Section 3.3.2, because of

- .1 defective Work not remedied;
- .2 third party claims filed or reasonable evidence indicating probable filing of such claims, unless security acceptable to the Owner is provided by the Contractor;
- .3 failure of the Contractor to make payments properly to Subcontractors or suppliers for labor, materials or equipment;

Init.

- .4 reasonable evidence that the Work cannot be completed for the unpaid balance of the Contract Sum;
- .5 damage to the Owner or a Separate Contractor;
- .6 reasonable evidence that the Work will not be completed within the Contract Time, and that the unpaid balance would not be adequate to cover actual or liquidated damages for the anticipated delay; or
- .7 repeated failure to carry out the Work in accordance with the Contract Documents.

§ 9.5.2 When either party disputes the Architect's decision regarding a Certificate for Payment under Section 9.5.1, in whole or in part, that party may submit a Claim in accordance with Article 15.

§ 9.5.3 When the reasons for withholding certification are removed, certification will be made for amounts previously withheld.

§ 9.5.4 If the Architect withholds certification for payment under Section 9.5.1.3, the Owner may, at its sole option, issue joint checks to the Contractor and to any Subcontractor or supplier to whom the Contractor failed to make payment for Work properly performed or material or equipment suitably delivered. If the Owner makes payments by joint check, the Owner shall notify the Architect and the Contractor shall reflect such payment on its next Application for Payment.

§ 9.6 Progress Payments

§ 9.6.1 After the Architect has issued a Certificate for Payment, the Owner shall make payment in the manner and within the time provided in the Contract Documents, and shall so notify the Architect.

§ 9.6.2 The Contractor shall pay each Subcontractor, no later than seven days after receipt of payment from the Owner, the amount to which the Subcontractor is entitled, reflecting percentages actually retained from payments to the Contractor on account of the Subcontractor's portion of the Work. The Contractor shall, by appropriate agreement with each Subcontractor, require each Subcontractor to make payments to Sub-subcontractors in a similar manner.

§ 9.6.3 The Architect will, on request, furnish to a Subcontractor, if practicable, information regarding percentages of completion or amounts applied for by the Contractor and action taken thereon by the Architect and Owner on account of portions of the Work done by such Subcontractor.

§ 9.6.4 The Owner has the right to request written evidence from the Contractor that the Contractor has properly paid Subcontractors and suppliers amounts paid by the Owner to the Contractor for subcontracted Work. If the Contractor fails to furnish such evidence within seven days, the Owner shall have the right to contact Subcontractors and suppliers to ascertain whether they have been properly paid. Neither the Owner nor Architect shall have an obligation to pay, or to see to the payment of money to, a Subcontractor or supplier, except as may otherwise be required by law.

§ 9.6.5 The Contractor's payments to suppliers shall be treated in a manner similar to that provided in Sections 9.6.2, 9.6.3 and 9.6.4.

§ 9.6.6 A Certificate for Payment, a progress payment, or partial or entire use or occupancy of the Project by the Owner shall not constitute acceptance of Work not in accordance with the Contract Documents.

§ 9.6.7 Unless the Contractor provides the Owner with a payment bond in the full penal sum of the Contract Sum, payments received by the Contractor for Work properly performed by Subcontractors or provided by suppliers shall be held by the Contractor for those Subcontractors or suppliers who performed Work or furnished materials, or both, under contract with the Contractor for which payment was made by the Owner. Nothing contained herein shall require money to be placed in a separate account and not commingled with money of the Contractor, create any fiduciary liability or tort liability on the part of the Contractor for breach of trust, or entitle any person or entity to an award of punitive damages against the Contractor for breach of the requirements of this provision.

§ 9.6.8 Provided the Owner has fulfilled its payment obligations under the Contract Documents, the Contractor shall defend and indemnify the Owner from all loss, liability, damage or expense, including reasonable attorney's fees and litigation expenses, arising out of any lien claim or other claim for payment by any Subcontractor or supplier of any tier. Upon receipt of notice of a lien claim or other claim for payment, the Owner shall notify the Contractor. If approved by the applicable court, when required, the Contractor may substitute a surety bond for the property against which the lien or other claim for payment has been asserted.

§ 9.7 Failure of Payment

If the Architect does not issue a Certificate for Payment, through no fault of the Contractor, within seven days after receipt of the Contractor's Application for Payment, or if the Owner does not pay the Contractor within seven days after the date established in the Contract Documents, the amount certified by the Architect or awarded by binding dispute resolution, then the Contractor may, upon seven additional days' notice to the Owner and Architect, stop the Work until payment of the amount owing has been received. The Contract Time shall be extended appropriately and the Contract Sum shall be increased by the amount of the Contractor's reasonable costs of shutdown, delay and start-up, plus interest as provided for in the Contract Documents.

§ 9.8 Substantial Completion

§ 9.8.1 Substantial Completion is the stage in the progress of the Work when the Work or designated portion thereof is sufficiently complete in accordance with the Contract Documents so that the Owner can occupy or utilize the Work for its intended use.

§ 9.8.2 When the Contractor considers that the Work, or a portion thereof which the Owner agrees to accept separately, is substantially complete, the Contractor shall prepare and submit to the Architect a comprehensive list of items to be completed or corrected prior to final payment. Failure to include an item on such list does not alter the responsibility of the Contractor to complete all Work in accordance with the Contract Documents.

§ 9.8.3 Upon receipt of the Contractor's list, the Architect will make an inspection to determine whether the Work or designated portion thereof is substantially complete. If the Architect's inspection discloses any item, whether or not included on the Contractor's list, which is not sufficiently complete in accordance with the Contract Documents so that the Owner can occupy or utilize the Work or designated portion thereof for its intended use, the Contractor shall, before issuance of the Certificate of Substantial Completion, complete or correct such item upon notification by the Architect. In such case, the Contractor shall then submit a request for another inspection by the Architect to determine Substantial Completion.

§ 9.8.4 When the Work or designated portion thereof is substantially complete, the Architect will prepare a Certificate of Substantial Completion that shall establish the date of Substantial Completion; establish responsibilities of the Owner and Contractor for security, maintenance, heat, utilities, damage to the Work and insurance; and fix the time within which the Contractor shall finish all items on the list accompanying the Certificate. Warranties required by the Contract Documents shall commence on the date of Substantial Completion of the Work or designated portion thereof unless otherwise provided in the Certificate of Substantial Completion.

§ 9.8.5 The Certificate of Substantial Completion shall be submitted to the Owner and Contractor for their written acceptance of responsibilities assigned to them in the Certificate. Upon such acceptance, and consent of surety if any, the Owner shall make payment of retainage applying to the Work or designated portion thereof. Such payment shall be adjusted for Work that is incomplete or not in accordance with the requirements of the Contract Documents.

§ 9.9 Partial Occupancy or Use

§ 9.9.1 The Owner may occupy or use any completed or partially completed portion of the Work at any stage when such portion is designated by separate agreement with the Contractor, provided such occupancy or use is consented to by the insurer and authorized by public authorities having jurisdiction over the Project. Such partial occupancy or use may commence whether or not the portion is substantially complete, provided the Owner and Contractor have accepted in writing the responsibilities assigned to each of them for payments, retainage, if any, security, maintenance, heat, utilities, damage to the Work and insurance, and have agreed in writing concerning the period for correction of the Work and commencement of warranties required by the Contract Documents. When the Contractor considers a portion substantially complete, the Contractor shall prepare and submit a list to the Architect as provided under Section 9.8.2. Consent of the Contractor to partial occupancy or use shall not be unreasonably withheld. The stage of the progress of the Work shall be determined by written agreement between the Owner and Contractor or, if no agreement is reached, by decision of the Architect.

§ 9.9.2 Immediately prior to such partial occupancy or use, the Owner, Contractor, and Architect shall jointly inspect the area to be occupied or portion of the Work to be used in order to determine and record the condition of the Work.

§ 9.9.3 Unless otherwise agreed upon, partial occupancy or use of a portion or portions of the Work shall not constitute acceptance of Work not complying with the requirements of the Contract Documents.

§ 9.10 Final Completion and Final Payment

§ 9.10.1 Upon receipt of the Contractor's notice that the Work is ready for final inspection and acceptance and upon receipt of a final Application for Payment, the Architect will promptly make such inspection. When the Architect finds the Work acceptable under the Contract Documents and the Contract fully performed, the Architect will promptly issue a final Certificate for Payment stating that to the best of the Architect's knowledge, information and belief, and on the basis of the Architect's on-site visits and inspections, the Work has been completed in accordance with the Contract Documents and that the entire balance found to be due the Contractor and noted in the final Certificate is due and payable. The Architect's final Certificate for Payment will constitute a further representation that conditions listed in Section 9.10.2 as precedent to the Contractor's being entitled to final payment have been fulfilled.

§ 9.10.2 Neither final payment nor any remaining retained percentage shall become due until the Contractor submits to the Architect (1) an affidavit that payrolls, bills for materials and equipment, and other indebtedness connected with the Work for which the Owner or the Owner's property might be responsible or encumbered (less amounts withheld by Owner) have been paid or otherwise satisfied, (2) a certificate evidencing that insurance required by the Contract Documents to remain in force after final payment is currently in effect, (3) a written statement that the Contractor knows of no reason that the insurance will not be renewable to cover the period required by the Contract Documents, (4) consent of surety, if any, to final payment, (5) documentation of any special warranties, such as manufacturers' warranties or specific Subcontractor warranties, and (6) if required by the Owner, other data establishing payment or satisfaction of obligations, such as receipts and releases and waivers of liens, claims, security interests, or encumbrances arising out of the Contract, to the extent and in such form as may be designated by the Owner. If a Subcontractor refuses to furnish a release or waiver required by the Owner, the Contractor may furnish a bond satisfactory to the Owner to indemnify the Owner against such lien, claim, security interest, or encumbrance. If a lien, claim, security interest, or encumbrance remains unsatisfied after payments are made, the Contractor shall refund to the Owner all money that the Owner may be compelled to pay in discharging the lien, claim, security interest, or encumbrance, including all costs and reasonable attorneys' fees.

§ 9.10.3 If, after Substantial Completion of the Work, final completion thereof is materially delayed through no fault of the Contractor or by issuance of Change Orders affecting final completion, and the Architect so confirms, the Owner shall, upon application by the Contractor and certification by the Architect, and without terminating the Contract, make payment of the balance due for that portion of the Work fully completed, corrected, and accepted. If the remaining balance for Work not fully completed or corrected is less than retainage stipulated in the Contract Documents, and if bonds have been furnished, the written consent of the surety to payment of the balance due for that portion of the Work fully completed and accepted shall be submitted by the Contractor to the Architect prior to certification of such payment. Such payment shall be made under terms and conditions governing final payment, except that it shall not constitute a waiver of Claims.

§ 9.10.4 The making of final payment shall constitute a waiver of Claims by the Owner except those arising from

- .1 liens, Claims, security interests, or encumbrances arising out of the Contract and unsettled;
- .2 failure of the Work to comply with the requirements of the Contract Documents;
- .3 terms of special warranties required by the Contract Documents; or
- .4 audits performed by the Owner, if permitted by the Contract Documents, after final payment.

§ 9.10.5 Acceptance of final payment by the Contractor, a Subcontractor, or a supplier, shall constitute a waiver of claims by that payee except those previously made in writing and identified by that payee as unsettled at the time of final Application for Payment.

ARTICLE 10 PROTECTION OF PERSONS AND PROPERTY

§ 10.1 Safety Precautions and Programs

The Contractor shall be responsible for initiating, maintaining, and supervising all safety precautions and programs in connection with the performance of the Contract.

§ 10.2 Safety of Persons and Property

§ 10.2.1 The Contractor shall take reasonable precautions for safety of, and shall provide reasonable protection to prevent damage, injury, or loss to

Init.

/

- .1 employees on the Work and other persons who may be affected thereby;
- .2 the Work and materials and equipment to be incorporated therein, whether in storage on or off the site, under care, custody, or control of the Contractor, a Subcontractor, or a Sub-subcontractor; and
- .3 other property at the site or adjacent thereto, such as trees, shrubs, lawns, walks, pavements, roadways, structures, and utilities not designated for removal, relocation, or replacement in the course of construction.

§ 10.2.2 The Contractor shall comply with, and give notices required by applicable laws, statutes, ordinances, codes, rules and regulations, and lawful orders of public authorities, bearing on safety of persons or property or their protection from damage, injury, or loss.

§ 10.2.3 The Contractor shall implement, erect, and maintain, as required by existing conditions and performance of the Contract, reasonable safeguards for safety and protection, including posting danger signs and other warnings against hazards; promulgating safety regulations; and notifying the owners and users of adjacent sites and utilities of the safeguards.

§ 10.2.4 When use or storage of explosives or other hazardous materials or equipment, or unusual methods are necessary for execution of the Work, the Contractor shall exercise utmost care and carry on such activities under supervision of properly qualified personnel.

§ 10.2.5 The Contractor shall promptly remedy damage and loss (other than damage or loss insured under property insurance required by the Contract Documents) to property referred to in Sections 10.2.1.2 and 10.2.1.3 caused in whole or in part by the Contractor, a Subcontractor, a Sub-subcontractor, or anyone directly or indirectly employed by any of them, or by anyone for whose acts they may be liable and for which the Contractor is responsible under Sections 10.2.1.2 and 10.2.1.3. The Contractor may make a Claim for the cost to remedy the damage or loss to the extent such damage or loss is attributable to acts or omissions of the Owner or Architect or anyone directly or indirectly employed by either of them, or by anyone for whose acts either of them may be liable, and not attributable to the fault or negligence of the Contractor. The foregoing obligations of the Contractor are in addition to the Contractor's obligations under Section 3.18.

§ 10.2.6 The Contractor shall designate a responsible member of the Contractor's organization at the site whose duty shall be the prevention of accidents. This person shall be the Contractor's superintendent unless otherwise designated by the Contractor in writing to the Owner and Architect.

§ 10.2.7 The Contractor shall not permit any part of the construction or site to be loaded so as to cause damage or create an unsafe condition.

§ 10.2.8 Injury or Damage to Person or Property

If either party suffers injury or damage to person or property because of an act or omission of the other party, or of others for whose acts such party is legally responsible, notice of the injury or damage, whether or not insured, shall be given to the other party within a reasonable time not exceeding 21 days after discovery. The notice shall provide sufficient detail to enable the other party to investigate the matter.

§ 10.3 Hazardous Materials and Substances

§ 10.3.1 The Contractor is responsible for compliance with any requirements included in the Contract Documents regarding hazardous materials or substances. If the Contractor encounters a hazardous material or substance not addressed in the Contract Documents and if reasonable precautions will be inadequate to prevent foreseeable bodily injury or death to persons resulting from a material or substance, including but not limited to asbestos or polychlorinated biphenyl (PCB), encountered on the site by the Contractor, the Contractor shall, upon recognizing the condition, immediately stop Work in the affected area and notify the Owner and Architect of the condition.

§ 10.3.2 Upon receipt of the Contractor's notice, the Owner shall obtain the services of a licensed laboratory to verify the presence or absence of the material or substance reported by the Contractor and, in the event such material or substance is found to be present, to cause it to be rendered harmless. Unless otherwise required by the Contract Documents, the Owner shall furnish in writing to the Contractor and Architect the names and qualifications of persons or entities who are to perform tests verifying the presence or absence of the material or substance or who are to perform the task of removal or safe containment of the material or substance. The Contractor and the Architect will

promptly reply to the Owner in writing stating whether or not either has reasonable objection to the persons or entities proposed by the Owner. If either the Contractor or Architect has an objection to a person or entity proposed by the Owner, the Owner shall propose another to whom the Contractor and the Architect have no reasonable objection. When the material or substance has been rendered harmless, Work in the affected area shall resume upon written agreement of the Owner and Contractor. By Change Order, the Contract Time shall be extended appropriately and the Contract Sum shall be increased by the amount of the Contractor's reasonable additional costs of shutdown, delay, and start-up.

§ 10.3.3 To the fullest extent permitted by law, the Owner shall indemnify and hold harmless the Contractor, Subcontractors, Architect, Architect's consultants, and agents and employees of any of them from and against claims, damages, losses, and expenses, including but not limited to attorneys' fees, arising out of or resulting from performance of the Work in the affected area if in fact the material or substance presents the risk of bodily injury or death as described in Section 10.3.1 and has not been rendered harmless, provided that such claim, damage, loss, or expense is attributable to bodily injury, sickness, disease or death, or to injury to or destruction of tangible property (other than the Work itself), except to the extent that such damage, loss, or expense is due to the fault or negligence of the party seeking indemnity.

§ 10.3.4 The Owner shall not be responsible under this Section 10.3 for hazardous materials or substances the Contractor brings to the site unless such materials or substances are required by the Contract Documents. The Owner shall be responsible for hazardous materials or substances required by the Contract Documents, except to the extent of the Contractor's fault or negligence in the use and handling of such materials or substances.

§ 10.3.5 The Contractor shall reimburse the Owner for the cost and expense the Owner incurs (1) for remediation of hazardous materials or substances the Contractor brings to the site and negligently handles, or (2) where the Contractor fails to perform its obligations under Section 10.3.1, except to the extent that the cost and expense are due to the Owner's fault or negligence.

§ 10.3.6 If, without negligence on the part of the Contractor, the Contractor is held liable by a government agency for the cost of remediation of a hazardous material or substance solely by reason of performing Work as required by the Contract Documents, the Owner shall reimburse the Contractor for all cost and expense thereby incurred.

§ 10.4 Emergencies

In an emergency affecting safety of persons or property, the Contractor shall act, at the Contractor's discretion, to prevent threatened damage, injury, or loss. Additional compensation or extension of time claimed by the Contractor on account of an emergency shall be determined as provided in Article 15 and Article 7.

ARTICLE 11 INSURANCE AND BONDS

§ 11.1 Contractor's Insurance and Bonds

§ 11.1.1 The Contractor shall purchase and maintain insurance of the types and limits of liability, containing the endorsements, and subject to the terms and conditions, as described in the Agreement or elsewhere in the Contract Documents. The Contractor shall purchase and maintain the required insurance from an insurance company or insurance companies lawfully authorized to issue insurance in the jurisdiction where the Project is located. The Owner, Architect, and Architect's consultants shall be named as additional insureds under the Contractor's commercial general liability policy or as otherwise described in the Contract Documents.

§ 11.1.2 The Contractor shall provide surety bonds of the types, for such penal sums, and subject to such terms and conditions as required by the Contract Documents. The Contractor shall purchase and maintain the required bonds from a company or companies lawfully authorized to issue surety bonds in the jurisdiction where the Project is located.

§ 11.1.3 Upon the request of any person or entity appearing to be a potential beneficiary of bonds covering payment of obligations arising under the Contract, the Contractor shall promptly furnish a copy of the bonds or shall authorize a copy to be furnished.

§ 11.1.4 Notice of Cancellation or Expiration of Contractor's Required Insurance. Within three (3) business days of the date the Contractor becomes aware of an impending or actual cancellation or expiration of any insurance required by the Contract Documents, the Contractor shall provide notice to the Owner of such impending or actual cancellation or

expiration. Upon receipt of notice from the Contractor, the Owner shall, unless the lapse in coverage arises from an act or omission of the Owner, have the right to stop the Work until the lapse in coverage has been cured by the procurement of replacement coverage by the Contractor. The furnishing of notice by the Contractor shall not relieve the Contractor of any contractual obligation to provide any required coverage.

§ 11.2 Owner's Insurance

§ 11.2.1 The Owner shall purchase and maintain insurance of the types and limits of liability, containing the endorsements, and subject to the terms and conditions, as described in the Agreement or elsewhere in the Contract Documents. The Owner shall purchase and maintain the required insurance from an insurance company or insurance companies lawfully authorized to issue insurance in the jurisdiction where the Project is located.

§ 11.2.2 **Failure to Purchase Required Property Insurance.** If the Owner fails to purchase and maintain the required property insurance, with all of the coverages and in the amounts described in the Agreement or elsewhere in the Contract Documents, the Owner shall inform the Contractor in writing prior to commencement of the Work. Upon receipt of notice from the Owner, the Contractor may delay commencement of the Work and may obtain insurance that will protect the interests of the Contractor, Subcontractors, and Sub-Subcontractors in the Work. When the failure to provide coverage has been cured or resolved, the Contract Sum and Contract Time shall be equitably adjusted. In the event the Owner fails to procure coverage, the Owner waives all rights against the Contractor, Subcontractors, and Sub-subcontractors to the extent the loss to the Owner would have been covered by the insurance to have been procured by the Owner. The cost of the insurance shall be charged to the Owner by a Change Order. If the Owner does not provide written notice, and the Contractor is damaged by the failure or neglect of the Owner to purchase or maintain the required insurance, the Owner shall reimburse the Contractor for all reasonable costs and damages attributable thereto.

§ 11.2.3 **Notice of Cancellation or Expiration of Owner's Required Property Insurance.** Within three (3) business days of the date the Owner becomes aware of an impending or actual cancellation or expiration of any property insurance required by the Contract Documents, the Owner shall provide notice to the Contractor of such impending or actual cancellation or expiration. Unless the lapse in coverage arises from an act or omission of the Contractor: (1) the Contractor, upon receipt of notice from the Owner, shall have the right to stop the Work until the lapse in coverage has been cured by the procurement of replacement coverage by either the Owner or the Contractor; (2) the Contract Time and Contract Sum shall be equitably adjusted; and (3) the Owner waives all rights against the Contractor, Subcontractors, and Sub-subcontractors to the extent any loss to the Owner would have been covered by the insurance had it not expired or been cancelled. If the Contractor purchases replacement coverage, the cost of the insurance shall be charged to the Owner by an appropriate Change Order. The furnishing of notice by the Owner shall not relieve the Owner of any contractual obligation to provide required insurance.

§ 11.3 Waivers of Subrogation

§ 11.3.1 The Owner and Contractor waive all rights against (1) each other and any of their subcontractors, sub-subcontractors, agents, and employees, each of the other; (2) the Architect and Architect's consultants; and (3) Separate Contractors, if any, and any of their subcontractors, sub-subcontractors, agents, and employees, for damages caused by fire, or other causes of loss, to the extent those losses are covered by property insurance required by the Agreement or other property insurance applicable to the Project, except such rights as they have to proceeds of such insurance. The Owner or Contractor, as appropriate, shall require similar written waivers in favor of the individuals and entities identified above from the Architect, Architect's consultants, Separate Contractors, subcontractors, and sub-subcontractors. The policies of insurance purchased and maintained by each person or entity agreeing to waive claims pursuant to this section 11.3.1 shall not prohibit this waiver of subrogation. This waiver of subrogation shall be effective as to a person or entity (1) even though that person or entity would otherwise have a duty of indemnification, contractual or otherwise, (2) even though that person or entity did not pay the insurance premium directly or indirectly, or (3) whether or not the person or entity had an insurable interest in the damaged property.

§ 11.3.2 If during the Project construction period the Owner insures properties, real or personal or both, at or adjacent to the site by property insurance under policies separate from those insuring the Project, or if after final payment property insurance is to be provided on the completed Project through a policy or policies other than those insuring the Project during the construction period, to the extent permissible by such policies, the Owner waives all rights in accordance with the terms of Section 11.3.1 for damages caused by fire or other causes of loss covered by this separate property insurance.

§ 11.4 Loss of Use, Business Interruption, and Delay in Completion Insurance

The Owner, at the Owner's option, may purchase and maintain insurance that will protect the Owner against loss of use of the Owner's property, or the inability to conduct normal operations, due to fire or other causes of loss. The Owner waives all rights of action against the Contractor and Architect for loss of use of the Owner's property, due to fire or other hazards however caused.

§11.5 Adjustment and Settlement of Insured Loss

§ 11.5.1 A loss insured under the property insurance required by the Agreement shall be adjusted by the Owner as fiduciary and made payable to the Owner as fiduciary for the insureds, as their interests may appear, subject to requirements of any applicable mortgagee clause and of Section 11.5.2. The Owner shall pay the Architect and Contractor their just shares of insurance proceeds received by the Owner, and by appropriate agreements the Architect and Contractor shall make payments to their consultants and Subcontractors in similar manner.

§ 11.5.2 Prior to settlement of an insured loss, the Owner shall notify the Contractor of the terms of the proposed settlement as well as the proposed allocation of the insurance proceeds. The Contractor shall have 14 days from receipt of notice to object to the proposed settlement or allocation of the proceeds. If the Contractor does not object, the Owner shall settle the loss and the Contractor shall be bound by the settlement and allocation. Upon receipt, the Owner shall deposit the insurance proceeds in a separate account and make the appropriate distributions. Thereafter, if no other agreement is made or the Owner does not terminate the Contract for convenience, the Owner and Contractor shall execute a Change Order for reconstruction of the damaged or destroyed Work in the amount allocated for that purpose. If the Contractor timely objects to either the terms of the proposed settlement or the allocation of the proceeds, the Owner may proceed to settle the insured loss, and any dispute between the Owner and Contractor arising out of the settlement or allocation of the proceeds shall be resolved pursuant to Article 15. Pending resolution of any dispute, the Owner may issue a Construction Change Directive for the reconstruction of the damaged or destroyed Work.

ARTICLE 12 UNCOVERING AND CORRECTION OF WORK

§ 12.1 Uncovering of Work

§ 12.1.1 If a portion of the Work is covered contrary to the Architect's request or to requirements specifically expressed in the Contract Documents, it must, if requested in writing by the Architect, be uncovered for the Architect's examination and be replaced at the Contractor's expense without change in the Contract Time.

§ 12.1.2 If a portion of the Work has been covered that the Architect has not specifically requested to examine prior to its being covered, the Architect may request to see such Work and it shall be uncovered by the Contractor. If such Work is in accordance with the Contract Documents, the Contractor shall be entitled to an equitable adjustment to the Contract Sum and Contract Time as may be appropriate. If such Work is not in accordance with the Contract Documents, the costs of uncovering the Work, and the cost of correction, shall be at the Contractor's expense.

§ 12.2 Correction of Work

§ 12.2.1 Before Substantial Completion

The Contractor shall promptly correct Work rejected by the Architect or failing to conform to the requirements of the Contract Documents, discovered before Substantial Completion and whether or not fabricated, installed or completed. Costs of correcting such rejected Work, including additional testing and inspections, the cost of uncovering and replacement, and compensation for the Architect's services and expenses made necessary thereby, shall be at the Contractor's expense.

§ 12.2.2 After Substantial Completion

§ 12.2.2.1 In addition to the Contractor's obligations under Section 3.5, if, within one year after the date of Substantial Completion of the Work or designated portion thereof or after the date for commencement of warranties established under Section 9.9.1, or by terms of any applicable special warranty required by the Contract Documents, any of the Work is found to be not in accordance with the requirements of the Contract Documents, the Contractor shall correct it promptly after receipt of notice from the Owner to do so, unless the Owner has previously given the Contractor a written acceptance of such condition. The Owner shall give such notice promptly after discovery of the condition.

During the one-year period for correction of Work, if the Owner fails to notify the Contractor and give the Contractor an opportunity to make the correction, the Owner waives the rights to require correction by the Contractor and to make a claim for breach of warranty. If the Contractor fails to correct nonconforming Work within a reasonable time during

that period after receipt of notice from the Owner or Architect, the Owner may correct it in accordance with Section 2.5.

§ 12.2.2.2 The one-year period for correction of Work shall be extended with respect to portions of Work first performed after Substantial Completion by the period of time between Substantial Completion and the actual completion of that portion of the Work.

§ 12.2.2.3 The one-year period for correction of Work shall not be extended by corrective Work performed by the Contractor pursuant to this Section 12.2.

§ 12.2.3 The Contractor shall remove from the site portions of the Work that are not in accordance with the requirements of the Contract Documents and are neither corrected by the Contractor nor accepted by the Owner.

§ 12.2.4 The Contractor shall bear the cost of correcting destroyed or damaged construction of the Owner or Separate Contractors, whether completed or partially completed, caused by the Contractor's correction or removal of Work that is not in accordance with the requirements of the Contract Documents.

§ 12.2.5 Nothing contained in this Section 12.2 shall be construed to establish a period of limitation with respect to other obligations the Contractor has under the Contract Documents. Establishment of the one-year period for correction of Work as described in Section 12.2.2 relates only to the specific obligation of the Contractor to correct the Work, and has no relationship to the time within which the obligation to comply with the Contract Documents may be sought to be enforced, nor to the time within which proceedings may be commenced to establish the Contractor's liability with respect to the Contractor's obligations other than specifically to correct the Work.

§ 12.3 Acceptance of Nonconforming Work

If the Owner prefers to accept Work that is not in accordance with the requirements of the Contract Documents, the Owner may do so instead of requiring its removal and correction, in which case the Contract Sum will be reduced as appropriate and equitable. Such adjustment shall be effected whether or not final payment has been made.

ARTICLE 13 MISCELLANEOUS PROVISIONS

§ 13.1 Governing Law

The Contract shall be governed by the law of the place where the Project is located, excluding that jurisdiction's choice of law rules. If the parties have selected arbitration as the method of binding dispute resolution, the Federal Arbitration Act shall govern Section 15.4.

§ 13.2 Successors and Assigns

§ 13.2.1 The Owner and Contractor respectively bind themselves, their partners, successors, assigns, and legal representatives to covenants, agreements, and obligations contained in the Contract Documents. Except as provided in Section 13.2.2, neither party to the Contract shall assign the Contract as a whole without written consent of the other. If either party attempts to make an assignment without such consent, that party shall nevertheless remain legally responsible for all obligations under the Contract.

§ 13.2.2 The Owner may, without consent of the Contractor, assign the Contract to a lender providing construction financing for the Project, if the lender assumes the Owner's rights and obligations under the Contract Documents. The Contractor shall execute all consents reasonably required to facilitate the assignment.

§ 13.3 Rights and Remedies

§ 13.3.1 Duties and obligations imposed by the Contract Documents and rights and remedies available thereunder shall be in addition to and not a limitation of duties, obligations, rights, and remedies otherwise imposed or available by law.

§ 13.3.2 No action or failure to act by the Owner, Architect, or Contractor shall constitute a waiver of a right or duty afforded them under the Contract, nor shall such action or failure to act constitute approval of or acquiescence in a breach thereunder, except as may be specifically agreed upon in writing.

§ 13.4 Tests and Inspections

§ 13.4.1 Tests, inspections, and approvals of portions of the Work shall be made as required by the Contract Documents and by applicable laws, statutes, ordinances, codes, rules, and regulations or lawful orders of public authorities. Unless otherwise provided, the Contractor shall make arrangements for such tests, inspections, and approvals with an independent testing laboratory or entity acceptable to the Owner, or with the appropriate public authority, and shall bear all related costs of tests, inspections, and approvals. The Contractor shall give the Architect timely notice of when and where tests and inspections are to be made so that the Architect may be present for such procedures. The Owner shall bear costs of tests, inspections, or approvals that do not become requirements until after bids are received or negotiations concluded. The Owner shall directly arrange and pay for tests, inspections, or approvals where building codes or applicable laws or regulations so require.

§ 13.4.2 If the Architect, Owner, or public authorities having jurisdiction determine that portions of the Work require additional testing, inspection, or approval not included under Section 13.4.1, the Architect will, upon written authorization from the Owner, instruct the Contractor to make arrangements for such additional testing, inspection, or approval, by an entity acceptable to the Owner, and the Contractor shall give timely notice to the Architect of when and where tests and inspections are to be made so that the Architect may be present for such procedures. Such costs, except as provided in Section 13.4.3, shall be at the Owner's expense.

§ 13.4.3 If procedures for testing, inspection, or approval under Sections 13.4.1 and 13.4.2 reveal failure of the portions of the Work to comply with requirements established by the Contract Documents, all costs made necessary by such failure, including those of repeated procedures and compensation for the Architect's services and expenses, shall be at the Contractor's expense.

§ 13.4.4 Required certificates of testing, inspection, or approval shall, unless otherwise required by the Contract Documents, be secured by the Contractor and promptly delivered to the Architect.

§ 13.4.5 If the Architect is to observe tests, inspections, or approvals required by the Contract Documents, the Architect will do so promptly and, where practicable, at the normal place of testing.

§ 13.4.6 Tests or inspections conducted pursuant to the Contract Documents shall be made promptly to avoid unreasonable delay in the Work.

§ 13.5 Interest

Payments due and unpaid under the Contract Documents shall bear interest from the date payment is due at the rate the parties agree upon in writing or, in the absence thereof, at the legal rate prevailing from time to time at the place where the Project is located.

ARTICLE 14 TERMINATION OR SUSPENSION OF THE CONTRACT

§ 14.1 Termination by the Contractor

§ 14.1.1 The Contractor may terminate the Contract if the Work is stopped for a period of 30 consecutive days through no act or fault of the Contractor, a Subcontractor, a Sub-subcontractor, their agents or employees, or any other persons or entities performing portions of the Work, for any of the following reasons:

- .1 Issuance of an order of a court or other public authority having jurisdiction that requires all Work to be stopped;
- .2 An act of government, such as a declaration of national emergency, that requires all Work to be stopped;
- .3 Because the Architect has not issued a Certificate for Payment and has not notified the Contractor of the reason for withholding certification as provided in Section 9.4.1, or because the Owner has not made payment on a Certificate for Payment within the time stated in the Contract Documents; or
- .4 The Owner has failed to furnish to the Contractor reasonable evidence as required by Section 2.2.

§ 14.1.2 The Contractor may terminate the Contract if, through no act or fault of the Contractor, a Subcontractor, a Sub-subcontractor, their agents or employees, or any other persons or entities performing portions of the Work, repeated suspensions, delays, or interruptions of the entire Work by the Owner as described in Section 14.3, constitute in the aggregate more than 100 percent of the total number of days scheduled for completion, or 120 days in any 365-day period, whichever is less.

§ 14.1.3 If one of the reasons described in Section 14.1.1 or 14.1.2 exists, the Contractor may, upon seven days' notice to the Owner and Architect, terminate the Contract and recover from the Owner payment for Work executed, as well as reasonable overhead and profit on Work not executed, and costs incurred by reason of such termination.

§ 14.1.4 If the Work is stopped for a period of 60 consecutive days through no act or fault of the Contractor, a Subcontractor, a Sub-subcontractor, or their agents or employees or any other persons or entities performing portions of the Work because the Owner has repeatedly failed to fulfill the Owner's obligations under the Contract Documents with respect to matters important to the progress of the Work, the Contractor may, upon seven additional days' notice to the Owner and the Architect, terminate the Contract and recover from the Owner as provided in Section 14.1.3.

§ 14.2 Termination by the Owner for Cause

§ 14.2.1 The Owner may terminate the Contract if the Contractor

- .1 repeatedly refuses or fails to supply enough properly skilled workers or proper materials;
- .2 fails to make payment to Subcontractors or suppliers in accordance with the respective agreements between the Contractor and the Subcontractors or suppliers;
- .3 repeatedly disregards applicable laws, statutes, ordinances, codes, rules and regulations, or lawful orders of a public authority; or
- .4 otherwise is guilty of substantial breach of a provision of the Contract Documents.

§ 14.2.2 When any of the reasons described in Section 14.2.1 exist, and upon certification by the Architect that sufficient cause exists to justify such action, the Owner may, without prejudice to any other rights or remedies of the Owner and after giving the Contractor and the Contractor's surety, if any, seven days' notice, terminate employment of the Contractor and may, subject to any prior rights of the surety:

- .1 Exclude the Contractor from the site and take possession of all materials, equipment, tools, and construction equipment and machinery thereon owned by the Contractor;
- .2 Accept assignment of subcontracts pursuant to Section 5.4; and
- .3 Finish the Work by whatever reasonable method the Owner may deem expedient. Upon written request of the Contractor, the Owner shall furnish to the Contractor a detailed accounting of the costs incurred by the Owner in finishing the Work.

§ 14.2.3 When the Owner terminates the Contract for one of the reasons stated in Section 14.2.1, the Contractor shall not be entitled to receive further payment until the Work is finished.

§ 14.2.4 If the unpaid balance of the Contract Sum exceeds costs of finishing the Work, including compensation for the Architect's services and expenses made necessary thereby, and other damages incurred by the Owner and not expressly waived, such excess shall be paid to the Contractor. If such costs and damages exceed the unpaid balance, the Contractor shall pay the difference to the Owner. The amount to be paid to the Contractor or Owner, as the case may be, shall be certified by the Initial Decision Maker, upon application, and this obligation for payment shall survive termination of the Contract.

§ 14.3 Suspension by the Owner for Convenience

§ 14.3.1 The Owner may, without cause, order the Contractor in writing to suspend, delay or interrupt the Work, in whole or in part for such period of time as the Owner may determine.

§ 14.3.2 The Contract Sum and Contract Time shall be adjusted for increases in the cost and time caused by suspension, delay, or interruption under Section 14.3.1. Adjustment of the Contract Sum shall include profit. No adjustment shall be made to the extent

- .1 that performance is, was, or would have been, so suspended, delayed, or interrupted, by another cause for which the Contractor is responsible; or
- .2 that an equitable adjustment is made or denied under another provision of the Contract.

§ 14.4 Termination by the Owner for Convenience

§ 14.4.1 The Owner may, at any time, terminate the Contract for the Owner's convenience and without cause.

§ 14.4.2 Upon receipt of notice from the Owner of such termination for the Owner's convenience, the Contractor shall

- .1 cease operations as directed by the Owner in the notice;

- .2 take actions necessary, or that the Owner may direct, for the protection and preservation of the Work; and
- .3 except for Work directed to be performed prior to the effective date of termination stated in the notice, terminate all existing subcontracts and purchase orders and enter into no further subcontracts and purchase orders.

§ 14.4.3 In case of such termination for the Owner's convenience, the Owner shall pay the Contractor for Work properly executed; costs incurred by reason of the termination, including costs attributable to termination of Subcontracts; and the termination fee, if any, set forth in the Agreement.

ARTICLE 15 CLAIMS AND DISPUTES

§ 15.1 Claims

§ 15.1.1 Definition

A Claim is a demand or assertion by one of the parties seeking, as a matter of right, payment of money, a change in the Contract Time, or other relief with respect to the terms of the Contract. The term "Claim" also includes other disputes and matters in question between the Owner and Contractor arising out of or relating to the Contract. The responsibility to substantiate Claims shall rest with the party making the Claim. This Section 15.1.1 does not require the Owner to file a Claim in order to impose liquidated damages in accordance with the Contract Documents.

§ 15.1.2 Time Limits on Claims

The Owner and Contractor shall commence all Claims and causes of action against the other and arising out of or related to the Contract, whether in contract, tort, breach of warranty or otherwise, in accordance with the requirements of the binding dispute resolution method selected in the Agreement and within the period specified by applicable law, but in any case not more than 10 years after the date of Substantial Completion of the Work. The Owner and Contractor waive all Claims and causes of action not commenced in accordance with this Section 15.1.2.

§ 15.1.3 Notice of Claims

§ 15.1.3.1 Claims by either the Owner or Contractor, where the condition giving rise to the Claim is first discovered prior to expiration of the period for correction of the Work set forth in Section 12.2.2, shall be initiated by notice to the other party and to the Initial Decision Maker with a copy sent to the Architect, if the Architect is not serving as the Initial Decision Maker. Claims by either party under this Section 15.1.3.1 shall be initiated within 21 days after occurrence of the event giving rise to such Claim or within 21 days after the claimant first recognizes the condition giving rise to the Claim, whichever is later.

§ 15.1.3.2 Claims by either the Owner or Contractor, where the condition giving rise to the Claim is first discovered after expiration of the period for correction of the Work set forth in Section 12.2.2, shall be initiated by notice to the other party. In such event, no decision by the Initial Decision Maker is required.

§ 15.1.4 Continuing Contract Performance

§ 15.1.4.1 Pending final resolution of a Claim, except as otherwise agreed in writing or as provided in Section 9.7 and Article 14, the Contractor shall proceed diligently with performance of the Contract and the Owner shall continue to make payments in accordance with the Contract Documents.

§ 15.1.4.2 The Contract Sum and Contract Time shall be adjusted in accordance with the Initial Decision Maker's decision, subject to the right of either party to proceed in accordance with this Article 15. The Architect will issue Certificates for Payment in accordance with the decision of the Initial Decision Maker.

§ 15.1.5 Claims for Additional Cost

If the Contractor wishes to make a Claim for an increase in the Contract Sum, notice as provided in Section 15.1.3 shall be given before proceeding to execute the portion of the Work that is the subject of the Claim. Prior notice is not required for Claims relating to an emergency endangering life or property arising under Section 10.4.

§ 15.1.6 Claims for Additional Time

§ 15.1.6.1 If the Contractor wishes to make a Claim for an increase in the Contract Time, notice as provided in Section 15.1.3 shall be given. The Contractor's Claim shall include an estimate of cost and of probable effect of delay on progress of the Work. In the case of a continuing delay, only one Claim is necessary.

§ 15.1.6.2 If adverse weather conditions are the basis for a Claim for additional time, such Claim shall be documented by data substantiating that weather conditions were abnormal for the period of time, could not have been reasonably anticipated, and had an adverse effect on the scheduled construction.

§ 15.1.7 Waiver of Claims for Consequential Damages

The Contractor and Owner waive Claims against each other for consequential damages arising out of or relating to this Contract. This mutual waiver includes

- .1 damages incurred by the Owner for rental expenses, for losses of use, income, profit, financing, business and reputation, and for loss of management or employee productivity or of the services of such persons; and
- .2 damages incurred by the Contractor for principal office expenses including the compensation of personnel stationed there, for losses of financing, business and reputation, and for loss of profit, except anticipated profit arising directly from the Work.

This mutual waiver is applicable, without limitation, to all consequential damages due to either party's termination in accordance with Article 14. Nothing contained in this Section 15.1.7 shall be deemed to preclude assessment of liquidated damages, when applicable, in accordance with the requirements of the Contract Documents.

§ 15.2 Initial Decision

§ 15.2.1 Claims, excluding those where the condition giving rise to the Claim is first discovered after expiration of the period for correction of the Work set forth in Section 12.2.2 or arising under Sections 10.3, 10.4, and 11.5, shall be referred to the Initial Decision Maker for initial decision. The Architect will serve as the Initial Decision Maker, unless otherwise indicated in the Agreement. Except for those Claims excluded by this Section 15.2.1, an initial decision shall be required as a condition precedent to mediation of any Claim. If an initial decision has not been rendered within 30 days after the Claim has been referred to the Initial Decision Maker, the party asserting the Claim may demand mediation and binding dispute resolution without a decision having been rendered. Unless the Initial Decision Maker and all affected parties agree, the Initial Decision Maker will not decide disputes between the Contractor and persons or entities other than the Owner.

§ 15.2.2 The Initial Decision Maker will review Claims and within ten days of the receipt of a Claim take one or more of the following actions: (1) request additional supporting data from the claimant or a response with supporting data from the other party, (2) reject the Claim in whole or in part, (3) approve the Claim, (4) suggest a compromise, or (5) advise the parties that the Initial Decision Maker is unable to resolve the Claim if the Initial Decision Maker lacks sufficient information to evaluate the merits of the Claim or if the Initial Decision Maker concludes that, in the Initial Decision Maker's sole discretion, it would be inappropriate for the Initial Decision Maker to resolve the Claim.

§ 15.2.3 In evaluating Claims, the Initial Decision Maker may, but shall not be obligated to, consult with or seek information from either party or from persons with special knowledge or expertise who may assist the Initial Decision Maker in rendering a decision. The Initial Decision Maker may request the Owner to authorize retention of such persons at the Owner's expense.

§ 15.2.4 If the Initial Decision Maker requests a party to provide a response to a Claim or to furnish additional supporting data, such party shall respond, within ten days after receipt of the request, and shall either (1) provide a response on the requested supporting data, (2) advise the Initial Decision Maker when the response or supporting data will be furnished, or (3) advise the Initial Decision Maker that no supporting data will be furnished. Upon receipt of the response or supporting data, if any, the Initial Decision Maker will either reject or approve the Claim in whole or in part.

§ 15.2.5 The Initial Decision Maker will render an initial decision approving or rejecting the Claim, or indicating that the Initial Decision Maker is unable to resolve the Claim. This initial decision shall (1) be in writing; (2) state the reasons therefor; and (3) notify the parties and the Architect, if the Architect is not serving as the Initial Decision Maker, of any change in the Contract Sum or Contract Time or both. The initial decision shall be final and binding on the parties but subject to mediation and, if the parties fail to resolve their dispute through mediation, to binding dispute resolution.

§ 15.2.6 Either party may file for mediation of an initial decision at any time, subject to the terms of Section 15.2.6.1.

§ 15.2.6.1 Either party may, within 30 days from the date of receipt of an initial decision, demand in writing that the other party file for mediation. If such a demand is made and the party receiving the demand fails to file for mediation within 30 days after receipt thereof, then both parties waive their rights to mediate or pursue binding dispute resolution proceedings with respect to the initial decision.

§ 15.2.7 In the event of a Claim against the Contractor, the Owner may, but is not obligated to, notify the surety, if any, of the nature and amount of the Claim. If the Claim relates to a possibility of a Contractor's default, the Owner may, but is not obligated to, notify the surety and request the surety's assistance in resolving the controversy.

§ 15.2.8 If a Claim relates to or is the subject of a mechanic's lien, the party asserting such Claim may proceed in accordance with applicable law to comply with the lien notice or filing deadlines.

§ 15.3 Mediation

§ 15.3.1 Claims, disputes, or other matters in controversy arising out of or related to the Contract, except those waived as provided for in Sections 9.10.4, 9.10.5, and 15.1.7, shall be subject to mediation as a condition precedent to binding dispute resolution.

§ 15.3.2 The parties shall endeavor to resolve their Claims by mediation which, unless the parties mutually agree otherwise, shall be administered by the American Arbitration Association in accordance with its Construction Industry Mediation Procedures in effect on the date of the Agreement. A request for mediation shall be made in writing, delivered to the other party to the Contract, and filed with the person or entity administering the mediation. The request may be made concurrently with the filing of binding dispute resolution proceedings but, in such event, mediation shall proceed in advance of binding dispute resolution proceedings, which shall be stayed pending mediation for a period of 60 days from the date of filing, unless stayed for a longer period by agreement of the parties or court order. If an arbitration is stayed pursuant to this Section 15.3.2, the parties may nonetheless proceed to the selection of the arbitrator(s) and agree upon a schedule for later proceedings.

§ 15.3.3 Either party may, within 30 days from the date that mediation has been concluded without resolution of the dispute or 60 days after mediation has been demanded without resolution of the dispute, demand in writing that the other party file for binding dispute resolution. If such a demand is made and the party receiving the demand fails to file for binding dispute resolution within 60 days after receipt thereof, then both parties waive their rights to binding dispute resolution proceedings with respect to the initial decision.

§ 15.3.4 The parties shall share the mediator's fee and any filing fees equally. The mediation shall be held in the place where the Project is located, unless another location is mutually agreed upon. Agreements reached in mediation shall be enforceable as settlement agreements in any court having jurisdiction thereof.

§ 15.4 Arbitration

§ 15.4.1 If the parties have selected arbitration as the method for binding dispute resolution in the Agreement, any Claim subject to, but not resolved by, mediation shall be subject to arbitration which, unless the parties mutually agree otherwise, shall be administered by the American Arbitration Association in accordance with its Construction Industry Arbitration Rules in effect on the date of the Agreement. The Arbitration shall be conducted in the place where the Project is located, unless another location is mutually agreed upon. A demand for arbitration shall be made in writing, delivered to the other party to the Contract, and filed with the person or entity administering the arbitration. The party filing a notice of demand for arbitration must assert in the demand all Claims then known to that party on which arbitration is permitted to be demanded.

§ 15.4.1.1 A demand for arbitration shall be made no earlier than concurrently with the filing of a request for mediation, but in no event shall it be made after the date when the institution of legal or equitable proceedings based on the Claim would be barred by the applicable statute of limitations. For statute of limitations purposes, receipt of a written demand for arbitration by the person or entity administering the arbitration shall constitute the institution of legal or equitable proceedings based on the Claim.

§ 15.4.2 The award rendered by the arbitrator or arbitrators shall be final, and judgment may be entered upon it in accordance with applicable law in any court having jurisdiction thereof.

§ 15.4.3 The foregoing agreement to arbitrate and other agreements to arbitrate with an additional person or entity duly consented to by parties to the Agreement, shall be specifically enforceable under applicable law in any court having jurisdiction thereof.

§ 15.4.4 Consolidation or Joinder

§ 15.4.4.1 Subject to the rules of the American Arbitration Association or other applicable arbitration rules, either party may consolidate an arbitration conducted under this Agreement with any other arbitration to which it is a party provided that (1) the arbitration agreement governing the other arbitration permits consolidation, (2) the arbitrations to be consolidated substantially involve common questions of law or fact, and (3) the arbitrations employ materially similar procedural rules and methods for selecting arbitrator(s).

§ 15.4.4.2 Subject to the rules of the American Arbitration Association or other applicable arbitration rules, either party may include by joinder persons or entities substantially involved in a common question of law or fact whose presence is required if complete relief is to be accorded in arbitration, provided that the party sought to be joined consents in writing to such joinder. Consent to arbitration involving an additional person or entity shall not constitute consent to arbitration of any claim, dispute or other matter in question not described in the written consent.

§ 15.4.4.3 The Owner and Contractor grant to any person or entity made a party to an arbitration conducted under this Section 15.4, whether by joinder or consolidation, the same rights of joinder and consolidation as those of the Owner and Contractor under this Agreement.



AIA® Document A310™ – 2010

Bid Bond

CONTRACTOR:

(Name, legal status and address)

SURETY:

(Name, legal status and principal place of business)

OWNER:

(Name, legal status and address)

BOND AMOUNT: \$

PROJECT:

(Name, location or address, and Project number, if any)

This document has important legal consequences. Consultation with an attorney is encouraged with respect to its completion or modification.

Any singular reference to Contractor, Surety, Owner or other party shall be considered plural where applicable.

The Contractor and Surety are bound to the Owner in the amount set forth above, for the payment of which the Contractor and Surety bind themselves, their heirs, executors, administrators, successors and assigns, jointly and severally, as provided herein. The conditions of this Bond are such that if the Owner accepts the bid of the Contractor within the time specified in the bid documents, or within such time period as may be agreed to by the Owner and Contractor, and the Contractor either (1) enters into a contract with the Owner in accordance with the terms of such bid, and gives such bond or bonds as may be specified in the bidding or Contract Documents, with a surety admitted in the jurisdiction of the Project and otherwise acceptable to the Owner, for the faithful performance of such Contract and for the prompt payment of labor and material furnished in the prosecution thereof; or (2) pays to the Owner the difference, not to exceed the amount of this Bond, between the amount specified in said bid and such larger amount for which the Owner may in good faith contract with another party to perform the work covered by said bid, then this obligation shall be null and void, otherwise to remain in full force and effect. The Surety hereby waives any notice of an agreement between the Owner and Contractor to extend the time in which the Owner may accept the bid. Waiver of notice by the Surety shall not apply to any extension exceeding sixty (60) days in the aggregate beyond the time for acceptance of bids specified in the bid documents, and the Owner and Contractor shall obtain the Surety's consent for an extension beyond sixty (60) days.

If this Bond is issued in connection with a subcontractor's bid to a Contractor, the term Contractor in this Bond shall be deemed to be Subcontractor and the term Owner shall be deemed to be Contractor.

When this Bond has been furnished to comply with a statutory or other legal requirement in the location of the Project, any provision in this Bond conflicting with said statutory or legal requirement shall be deemed deleted herefrom and provisions conforming to such statutory or other legal requirement shall be deemed incorporated herein. When so furnished, the intent is that this Bond shall be construed as a statutory bond and not as a common law bond.

Init.

AIA Document A310™ – 2010. Copyright © 1963, 1970 and 2010 by The American Institute of Architects. All rights reserved. **WARNING: This AIA® Document is protected by U.S. Copyright Law and International Treaties. Unauthorized reproduction or distribution of this AIA® Document, or any portion of it, may result in severe civil and criminal penalties, and will be prosecuted to the maximum extent possible under the law.** This document was produced by AIA software at 17:35:54 ET on 05/20/2019 under Order No.0077529913 which expires on 03/27/2020, and is not for resale.

User Notes:

(1195795511)

Signed and sealed this day of ,

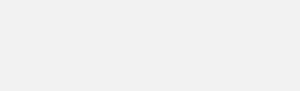

(Contractor as Principal) *(Seal)*

(Witness)

(Title)

(Surety) *(Seal)*

(Witness)

(Title)

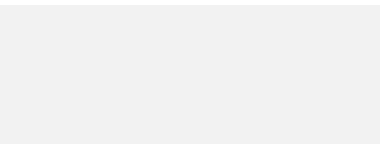

Init.

/



AIA[®]

Document A312™ – 2010

Payment Bond

CONTRACTOR:

(Name, legal status and address)

SURETY:

(Name, legal status and principal place of business)

OWNER:

(Name, legal status and address)

This document has important legal consequences. Consultation with an attorney is encouraged with respect to its completion or modification.

CONSTRUCTION CONTRACT

Date:

Amount: \$ 0.00

Description:

(Name and location)

Any singular reference to Contractor, Surety, Owner or other party shall be considered plural where applicable.

BOND

Date:

(Not earlier than Construction Contract Date)

Amount: \$

Modifications to this Bond: None See Section 18

CONTRACTOR AS PRINCIPAL

Company: *(Corporate Seal)*

SURETY

Company: *(Corporate Seal)*

Signature: _____

Name and

Title:

(Any additional signatures appear on the last page of this Payment Bond.)

Signature: _____

Name and

Title:

(FOR INFORMATION ONLY — Name, address and telephone)

AGENT or BROKER:

OWNER'S REPRESENTATIVE:

(Architect, Engineer or other party:)

§ 1 The Contractor and Surety, jointly and severally, bind themselves, their heirs, executors, administrators, successors and assigns to the Owner to pay for labor, materials and equipment furnished for use in the performance of the Construction Contract, which is incorporated herein by reference, subject to the following terms.

§ 2 If the Contractor promptly makes payment of all sums due to Claimants, and defends, indemnifies and holds harmless the Owner from claims, demands, liens or suits by any person or entity seeking payment for labor, materials or equipment furnished for use in the performance of the Construction Contract, then the Surety and the Contractor shall have no obligation under this Bond.

§ 3 If there is no Owner Default under the Construction Contract, the Surety's obligation to the Owner under this Bond shall arise after the Owner has promptly notified the Contractor and the Surety (at the address described in Section 13) of claims, demands, liens or suits against the Owner or the Owner's property by any person or entity seeking payment for labor, materials or equipment furnished for use in the performance of the Construction Contract and tendered defense of such claims, demands, liens or suits to the Contractor and the Surety.

§ 4 When the Owner has satisfied the conditions in Section 3, the Surety shall promptly and at the Surety's expense defend, indemnify and hold harmless the Owner against a duly tendered claim, demand, lien or suit.

§ 5 The Surety's obligations to a Claimant under this Bond shall arise after the following:

§ 5.1 Claimants, who do not have a direct contract with the Contractor,

- .1 have furnished a written notice of non-payment to the Contractor, stating with substantial accuracy the amount claimed and the name of the party to whom the materials were, or equipment was, furnished or supplied or for whom the labor was done or performed, within ninety (90) days after having last performed labor or last furnished materials or equipment included in the Claim; and
- .2 have sent a Claim to the Surety (at the address described in Section 13).

§ 5.2 Claimants, who are employed by or have a direct contract with the Contractor, have sent a Claim to the Surety (at the address described in Section 13).

§ 6 If a notice of non-payment required by Section 5.1.1 is given by the Owner to the Contractor, that is sufficient to satisfy a Claimant's obligation to furnish a written notice of non-payment under Section 5.1.1.

§ 7 When a Claimant has satisfied the conditions of Sections 5.1 or 5.2, whichever is applicable, the Surety shall promptly and at the Surety's expense take the following actions:

§ 7.1 Send an answer to the Claimant, with a copy to the Owner, within sixty (60) days after receipt of the Claim, stating the amounts that are undisputed and the basis for challenging any amounts that are disputed; and

§ 7.2 Pay or arrange for payment of any undisputed amounts.

§ 7.3 The Surety's failure to discharge its obligations under Section 7.1 or Section 7.2 shall not be deemed to constitute a waiver of defenses the Surety or Contractor may have or acquire as to a Claim, except as to undisputed amounts for which the Surety and Claimant have reached agreement. If, however, the Surety fails to discharge its obligations under Section 7.1 or Section 7.2, the Surety shall indemnify the Claimant for the reasonable attorney's fees the Claimant incurs thereafter to recover any sums found to be due and owing to the Claimant.

§ 8 The Surety's total obligation shall not exceed the amount of this Bond, plus the amount of reasonable attorney's fees provided under Section 7.3, and the amount of this Bond shall be credited for any payments made in good faith by the Surety.

§ 9 Amounts owed by the Owner to the Contractor under the Construction Contract shall be used for the performance of the Construction Contract and to satisfy claims, if any, under any construction performance bond. By the Contractor furnishing and the Owner accepting this Bond, they agree that all funds earned by the Contractor in the performance of the Construction Contract are dedicated to satisfy obligations of the Contractor and Surety under this Bond, subject to the Owner's priority to use the funds for the completion of the work.

§ 10 The Surety shall not be liable to the Owner, Claimants or others for obligations of the Contractor that are unrelated to the Construction Contract. The Owner shall not be liable for the payment of any costs or expenses of any Claimant under this Bond, and shall have under this Bond no obligation to make payments to, or give notice on behalf of, Claimants or otherwise have any obligations to Claimants under this Bond.

§ 11 The Surety hereby waives notice of any change, including changes of time, to the Construction Contract or to related subcontracts, purchase orders and other obligations.

§ 12 No suit or action shall be commenced by a Claimant under this Bond other than in a court of competent jurisdiction in the state in which the project that is the subject of the Construction Contract is located or after the expiration of one year from the date (1) on which the Claimant sent a Claim to the Surety pursuant to Section 5.1.2 or 5.2, or (2) on which the last labor or service was performed by anyone or the last materials or equipment were furnished by anyone under the Construction Contract, whichever of (1) or (2) first occurs. If the provisions of this Paragraph are void or prohibited by law, the minimum period of limitation available to sureties as a defense in the jurisdiction of the suit shall be applicable.

§ 13 Notice and Claims to the Surety, the Owner or the Contractor shall be mailed or delivered to the address shown on the page on which their signature appears. Actual receipt of notice or Claims, however accomplished, shall be sufficient compliance as of the date received.

§ 14 When this Bond has been furnished to comply with a statutory or other legal requirement in the location where the construction was to be performed, any provision in this Bond conflicting with said statutory or legal requirement shall be deemed deleted herefrom and provisions conforming to such statutory or other legal requirement shall be deemed incorporated herein. When so furnished, the intent is that this Bond shall be construed as a statutory bond and not as a common law bond.

§ 15 Upon request by any person or entity appearing to be a potential beneficiary of this Bond, the Contractor and Owner shall promptly furnish a copy of this Bond or shall permit a copy to be made.

§ 16 Definitions

§ 16.1 Claim. A written statement by the Claimant including at a minimum:

- .1 the name of the Claimant;
- .2 the name of the person for whom the labor was done, or materials or equipment furnished;
- .3 a copy of the agreement or purchase order pursuant to which labor, materials or equipment was furnished for use in the performance of the Construction Contract;
- .4 a brief description of the labor, materials or equipment furnished;
- .5 the date on which the Claimant last performed labor or last furnished materials or equipment for use in the performance of the Construction Contract;
- .6 the total amount earned by the Claimant for labor, materials or equipment furnished as of the date of the Claim;
- .7 the total amount of previous payments received by the Claimant; and
- .8 the total amount due and unpaid to the Claimant for labor, materials or equipment furnished as of the date of the Claim.

§ 16.2 Claimant. An individual or entity having a direct contract with the Contractor or with a subcontractor of the Contractor to furnish labor, materials or equipment for use in the performance of the Construction Contract. The term Claimant also includes any individual or entity that has rightfully asserted a claim under an applicable mechanic's lien or similar statute against the real property upon which the Project is located. The intent of this Bond shall be to include without limitation in the terms "labor, materials or equipment" that part of water, gas, power, light, heat, oil, gasoline, telephone service or rental equipment used in the Construction Contract, architectural and engineering services required for performance of the work of the Contractor and the Contractor's subcontractors, and all other items for which a mechanic's lien may be asserted in the jurisdiction where the labor, materials or equipment were furnished.

§ 16.3 Construction Contract. The agreement between the Owner and Contractor identified on the cover page, including all Contract Documents and all changes made to the agreement and the Contract Documents.

§ 16.4 Owner Default. Failure of the Owner, which has not been remedied or waived, to pay the Contractor as required under the Construction Contract or to perform and complete or comply with the other material terms of the Construction Contract.

§ 16.5 Contract Documents. All the documents that comprise the agreement between the Owner and Contractor.

§ 17 If this Bond is issued for an agreement between a Contractor and subcontractor, the term Contractor in this Bond shall be deemed to be Subcontractor and the term Owner shall be deemed to be Contractor.

§ 18 Modifications to this bond are as follows:

(Space is provided below for additional signatures of added parties, other than those appearing on the cover page.)

CONTRACTOR AS PRINCIPAL

Company: _____ (Corporate Seal)

Signature: _____
Name and Title: _____
Address: _____

SURETY

Company: _____ (Corporate Seal)

Signature: _____
Name and Title: _____
Address: _____



AIA[®] Document A312[™] – 2010

Performance Bond

CONTRACTOR:

(Name, legal status and address)

SURETY:

(Name, legal status and principal place of business)

OWNER:

(Name, legal status and address)

CONSTRUCTION CONTRACT

Date:

Amount: \$ 0.00

Description:

(Name and location)

AIA

BOND

Date:

(Not earlier than Construction Contract Date)

Amount: \$

Modifications to this Bond: None See Section 16

CONTRACTOR AS PRINCIPAL

Company: *(Corporate Seal)*

Signature: _____

Name and

Title:

(Any additional signatures appear on the last page of this Performance Bond.)

SURETY

Company: *(Corporate Seal)*

Signature: _____

Name and

Title:

(FOR INFORMATION ONLY — Name, address and telephone)

AGENT or BROKER:**OWNER'S REPRESENTATIVE:**

(Architect, Engineer or other party:)

This document has important legal consequences. Consultation with an attorney is encouraged with respect to its completion or modification.

Any singular reference to Contractor, Surety, Owner or other party shall be considered plural where applicable.

Init.

AIA Document A312[™] – 2010 Performance Bond. The American Institute of Architects. All rights reserved. **WARNING: This AIA[®] Document is protected by U.S. Copyright Law and International Treaties. Unauthorized reproduction or distribution of this AIA[®] Document, or any portion of it, may result in severe civil and criminal penalties, and will be prosecuted to the maximum extent possible under the law.** This document was produced by AIA software at 17:33:26 ET on 05/20/2019 under Order No.0077529913 which expires on 03/27/2020, and is not for resale.

User Notes:

(1215068777)

§ 1 The Contractor and Surety, jointly and severally, bind themselves, their heirs, executors, administrators, successors and assigns to the Owner for the performance of the Construction Contract, which is incorporated herein by reference.

§ 2 If the Contractor performs the Construction Contract, the Surety and the Contractor shall have no obligation under this Bond, except when applicable to participate in a conference as provided in Section 3.

§ 3 If there is no Owner Default under the Construction Contract, the Surety's obligation under this Bond shall arise after

- .1 the Owner first provides notice to the Contractor and the Surety that the Owner is considering declaring a Contractor Default. Such notice shall indicate whether the Owner is requesting a conference among the Owner, Contractor and Surety to discuss the Contractor's performance. If the Owner does not request a conference, the Surety may, within five (5) business days after receipt of the Owner's notice, request such a conference. If the Surety timely requests a conference, the Owner shall attend. Unless the Owner agrees otherwise, any conference requested under this Section 3.1 shall be held within ten (10) business days of the Surety's receipt of the Owner's notice. If the Owner, the Contractor and the Surety agree, the Contractor shall be allowed a reasonable time to perform the Construction Contract, but such an agreement shall not waive the Owner's right, if any, subsequently to declare a Contractor Default;
- .2 the Owner declares a Contractor Default, terminates the Construction Contract and notifies the Surety; and
- .3 the Owner has agreed to pay the Balance of the Contract Price in accordance with the terms of the Construction Contract to the Surety or to a contractor selected to perform the Construction Contract.

§ 4 Failure on the part of the Owner to comply with the notice requirement in Section 3.1 shall not constitute a failure to comply with a condition precedent to the Surety's obligations, or release the Surety from its obligations, except to the extent the Surety demonstrates actual prejudice.

§ 5 When the Owner has satisfied the conditions of Section 3, the Surety shall promptly and at the Surety's expense take one of the following actions:

§ 5.1 Arrange for the Contractor, with the consent of the Owner, to perform and complete the Construction Contract;

§ 5.2 Undertake to perform and complete the Construction Contract itself, through its agents or independent contractors;

§ 5.3 Obtain bids or negotiated proposals from qualified contractors acceptable to the Owner for a contract for performance and completion of the Construction Contract, arrange for a contract to be prepared for execution by the Owner and a contractor selected with the Owner's concurrence, to be secured with performance and payment bonds executed by a qualified surety equivalent to the bonds issued on the Construction Contract, and pay to the Owner the amount of damages as described in Section 7 in excess of the Balance of the Contract Price incurred by the Owner as a result of the Contractor Default; or

§ 5.4 Waive its right to perform and complete, arrange for completion, or obtain a new contractor and with reasonable promptness under the circumstances:

- .1 After investigation, determine the amount for which it may be liable to the Owner and, as soon as practicable after the amount is determined, make payment to the Owner; or
- .2 Deny liability in whole or in part and notify the Owner, citing the reasons for denial.

§ 6 If the Surety does not proceed as provided in Section 5 with reasonable promptness, the Surety shall be deemed to be in default on this Bond seven days after receipt of an additional written notice from the Owner to the Surety demanding that the Surety perform its obligations under this Bond, and the Owner shall be entitled to enforce any remedy available to the Owner. If the Surety proceeds as provided in Section 5.4, and the Owner refuses the payment or the Surety has denied liability, in whole or in part, without further notice the Owner shall be entitled to enforce any remedy available to the Owner.

§ 7 If the Surety elects to act under Section 5.1, 5.2 or 5.3, then the responsibilities of the Surety to the Owner shall not be greater than those of the Contractor under the Construction Contract, and the responsibilities of the Owner to the

Init.

AIA Document A312™ – 2010 Performance Bond. The American Institute of Architects. All rights reserved. **WARNING: This AIA® Document is protected by U.S. Copyright Law and International Treaties. Unauthorized reproduction or distribution of this AIA® Document, or any portion of it, may result in severe civil and criminal penalties, and will be prosecuted to the maximum extent possible under the law.** This document was produced by AIA software at 17:33:26 ET on 05/20/2019 under Order No.0077529913 which expires on 03/27/2020, and is not for resale.

User Notes:

(1215068777)

Surety shall not be greater than those of the Owner under the Construction Contract. Subject to the commitment by the Owner to pay the Balance of the Contract Price, the Surety is obligated, without duplication, for

- .1 the responsibilities of the Contractor for correction of defective work and completion of the Construction Contract;
- .2 additional legal, design professional and delay costs resulting from the Contractor's Default, and resulting from the actions or failure to act of the Surety under Section 5; and
- .3 liquidated damages, or if no liquidated damages are specified in the Construction Contract, actual damages caused by delayed performance or non-performance of the Contractor.

§ 8 If the Surety elects to act under Section 5.1, 5.3 or 5.4, the Surety's liability is limited to the amount of this Bond.

§ 9 The Surety shall not be liable to the Owner or others for obligations of the Contractor that are unrelated to the Construction Contract, and the Balance of the Contract Price shall not be reduced or set off on account of any such unrelated obligations. No right of action shall accrue on this Bond to any person or entity other than the Owner or its heirs, executors, administrators, successors and assigns.

§ 10 The Surety hereby waives notice of any change, including changes of time, to the Construction Contract or to related subcontracts, purchase orders and other obligations.

§ 11 Any proceeding, legal or equitable, under this Bond may be instituted in any court of competent jurisdiction in the location in which the work or part of the work is located and shall be instituted within two years after a declaration of Contractor Default or within two years after the Contractor ceased working or within two years after the Surety refuses or fails to perform its obligations under this Bond, whichever occurs first. If the provisions of this Paragraph are void or prohibited by law, the minimum period of limitation available to sureties as a defense in the jurisdiction of the suit shall be applicable.

§ 12 Notice to the Surety, the Owner or the Contractor shall be mailed or delivered to the address shown on the page on which their signature appears.

§ 13 When this Bond has been furnished to comply with a statutory or other legal requirement in the location where the construction was to be performed, any provision in this Bond conflicting with said statutory or legal requirement shall be deemed deleted herefrom and provisions conforming to such statutory or other legal requirement shall be deemed incorporated herein. When so furnished, the intent is that this Bond shall be construed as a statutory bond and not as a common law bond.

§ 14 Definitions

§ 14.1 Balance of the Contract Price. The total amount payable by the Owner to the Contractor under the Construction Contract after all proper adjustments have been made, including allowance to the Contractor of any amounts received or to be received by the Owner in settlement of insurance or other claims for damages to which the Contractor is entitled, reduced by all valid and proper payments made to or on behalf of the Contractor under the Construction Contract.

§ 14.2 Construction Contract. The agreement between the Owner and Contractor identified on the cover page, including all Contract Documents and changes made to the agreement and the Contract Documents.

§ 14.3 Contractor Default. Failure of the Contractor, which has not been remedied or waived, to perform or otherwise to comply with a material term of the Construction Contract.

§ 14.4 Owner Default. Failure of the Owner, which has not been remedied or waived, to pay the Contractor as required under the Construction Contract or to perform and complete or comply with the other material terms of the Construction Contract.

§ 14.5 Contract Documents. All the documents that comprise the agreement between the Owner and Contractor.

§ 15 If this Bond is issued for an agreement between a Contractor and subcontractor, the term Contractor in this Bond shall be deemed to be Subcontractor and the term Owner shall be deemed to be Contractor.

§ 16 Modifications to this bond are as follows:

(Space is provided below for additional signatures of added parties, other than those appearing on the cover page.)

CONTRACTOR AS PRINCIPAL

SURETY

Company: _____
(Corporate Seal)

Company: _____
(Corporate Seal)

Signature: _____
Name and Title: _____
Address: _____

Signature: _____
Name and Title: _____
Address: _____



Init.

/

User Notes:

(1215068777)



AIA[®] Document A701[™] – 2018

Instructions to Bidders

for the following Project:
(Name, location, and detailed description)

THE OWNER:
(Name, legal status, address, and other information)

THE ARCHITECT:
(Name, legal status, address, and other information)

TABLE OF ARTICLES

1	DEFINITIONS
2	BIDDER'S REPRESENTATIONS
3	BIDDING DOCUMENTS
4	BIDDING PROCEDURES
5	CONSIDERATION OF BIDS
6	POST-BID INFORMATION
7	PERFORMANCE BOND AND PAYMENT BOND
8	ENUMERATION OF THE PROPOSED CONTRACT DOCUMENTS

This document has important legal consequences. Consultation with an attorney is encouraged with respect to its completion or modification.

FEDERAL, STATE, AND LOCAL LAWS MAY IMPOSE REQUIREMENTS ON PUBLIC PROCUREMENT CONTRACTS. CONSULT LOCAL AUTHORITIES OR AN ATTORNEY TO VERIFY REQUIREMENTS APPLICABLE TO THIS PROCUREMENT BEFORE COMPLETING THIS FORM.

It is intended that AIA Document G612[™]-2017, Owner's Instructions to the Architect, Parts A and B will be completed prior to using this document.

ARTICLE 1 DEFINITIONS

§ 1.1 Bidding Documents include the Bidding Requirements and the Proposed Contract Documents. The Bidding Requirements consist of the advertisement or invitation to bid, Instructions to Bidders, supplementary instructions to bidders, the bid form, and any other bidding forms. The Proposed Contract Documents consist of the unexecuted form of Agreement between the Owner and Contractor and that Agreement's Exhibits, Conditions of the Contract (General, Supplementary and other Conditions), Drawings, Specifications, all Addenda, and all other documents enumerated in Article 8 of these Instructions.

§ 1.2 Definitions set forth in the General Conditions of the Contract for Construction, or in other Proposed Contract Documents apply to the Bidding Documents.

§ 1.3 Addenda are written or graphic instruments issued by the Architect, which, by additions, deletions, clarifications, or corrections, modify or interpret the Bidding Documents.

§ 1.4 A Bid is a complete and properly executed proposal to do the Work for the sums stipulated therein, submitted in accordance with the Bidding Documents.

§ 1.5 The Base Bid is the sum stated in the Bid for which the Bidder offers to perform the Work described in the Bidding Documents, to which Work may be added or deleted by sums stated in Alternate Bids.

§ 1.6 An Alternate Bid (or Alternate) is an amount stated in the Bid to be added to or deducted from, or that does not change, the Base Bid if the corresponding change in the Work, as described in the Bidding Documents, is accepted.

§ 1.7 A Unit Price is an amount stated in the Bid as a price per unit of measurement for materials, equipment, or services, or a portion of the Work, as described in the Bidding Documents.

§ 1.8 A Bidder is a person or entity who submits a Bid and who meets the requirements set forth in the Bidding Documents.

§ 1.9 A Sub-bidder is a person or entity who submits a bid to a Bidder for materials, equipment, or labor for a portion of the Work.

ARTICLE 2 BIDDER'S REPRESENTATIONS

§ 2.1 By submitting a Bid, the Bidder represents that:

- .1 the Bidder has read and understands the Bidding Documents;
- .2 the Bidder understands how the Bidding Documents relate to other portions of the Project, if any, being bid concurrently or presently under construction;
- .3 the Bid complies with the Bidding Documents;
- .4 the Bidder has visited the site, become familiar with local conditions under which the Work is to be performed, and has correlated the Bidder's observations with the requirements of the Proposed Contract Documents;
- .5 the Bid is based upon the materials, equipment, and systems required by the Bidding Documents without exception; and
- .6 the Bidder has read and understands the provisions for liquidated damages, if any, set forth in the form of Agreement between the Owner and Contractor.

ARTICLE 3 BIDDING DOCUMENTS

§ 3.1 Distribution

§ 3.1.1 Bidders shall obtain complete Bidding Documents, as indicated below, from the issuing office designated in the advertisement or invitation to bid, for the deposit sum, if any, stated therein.

(Indicate how, such as by email, website, host site/platform, paper copy, or other method Bidders shall obtain Bidding Documents.)

§ 3.1.2 Any required deposit shall be refunded to Bidders who submit a bona fide Bid and return the paper Bidding Documents in good condition within ten days after receipt of Bids. The cost to replace missing or damaged paper documents will be deducted from the deposit. A Bidder receiving a Contract award may retain the paper Bidding Documents, and the Bidder's deposit will be refunded.

§ 3.1.3 Bidding Documents will not be issued directly to Sub-bidders unless specifically offered in the advertisement or invitation to bid, or in supplementary instructions to bidders.

§ 3.1.4 Bidders shall use complete Bidding Documents in preparing Bids. Neither the Owner nor Architect assumes responsibility for errors or misinterpretations resulting from the use of incomplete Bidding Documents.

§ 3.1.5 The Bidding Documents will be available for the sole purpose of obtaining Bids on the Work. No license or grant of use is conferred by distribution of the Bidding Documents.

§ 3.2 Modification or Interpretation of Bidding Documents

§ 3.2.1 The Bidder shall carefully study the Bidding Documents, shall examine the site and local conditions, and shall notify the Architect of errors, inconsistencies, or ambiguities discovered and request clarification or interpretation pursuant to Section 3.2.2.

§ 3.2.2 Requests for clarification or interpretation of the Bidding Documents shall be submitted by the Bidder in writing and shall be received by the Architect at least seven days prior to the date for receipt of Bids.
(Indicate how, such as by email, website, host site/platform, paper copy, or other method Bidders shall submit requests for clarification and interpretation.)

§ 3.2.3 Modifications and interpretations of the Bidding Documents shall be made by Addendum. Modifications and interpretations of the Bidding Documents made in any other manner shall not be binding, and Bidders shall not rely upon them.

§ 3.3 Substitutions

§ 3.3.1 The materials, products, and equipment described in the Bidding Documents establish a standard of required function, dimension, appearance, and quality to be met by any proposed substitution.

§ 3.3.2 Substitution Process

§ 3.3.2.1 Written requests for substitutions shall be received by the Architect at least ten days prior to the date for receipt of Bids. Requests shall be submitted in the same manner as that established for submitting clarifications and interpretations in Section 3.2.2.

§ 3.3.2.2 Bidders shall submit substitution requests on a Substitution Request Form if one is provided in the Bidding Documents.

§ 3.3.2.3 If a Substitution Request Form is not provided, requests shall include (1) the name of the material or equipment specified in the Bidding Documents; (2) the reason for the requested substitution; (3) a complete description of the proposed substitution including the name of the material or equipment proposed as the substitute, performance and test data, and relevant drawings; and (4) any other information necessary for an evaluation. The request shall include a statement setting forth changes in other materials, equipment, or other portions of the Work, including changes in the work of other contracts or the impact on any Project Certifications (such as LEED), that will result from incorporation of the proposed substitution.

§ 3.3.3 The burden of proof of the merit of the proposed substitution is upon the proposer. The Architect's decision of approval or disapproval of a proposed substitution shall be final.

§ 3.3.4 If the Architect approves a proposed substitution prior to receipt of Bids, such approval shall be set forth in an Addendum. Approvals made in any other manner shall not be binding, and Bidders shall not rely upon them.

§ 3.3.5 No substitutions will be considered after the Contract award unless specifically provided for in the Contract Documents.

§ 3.4 Addenda

§ 3.4.1 Addenda will be transmitted to Bidders known by the issuing office to have received complete Bidding Documents.

(Indicate how, such as by email, website, host site/platform, paper copy, or other method Addenda will be transmitted.)

§ 3.4.2 Addenda will be available where Bidding Documents are on file.

§ 3.4.3 Addenda will be issued no later than four days prior to the date for receipt of Bids, except an Addendum withdrawing the request for Bids or one which includes postponement of the date for receipt of Bids.

§ 3.4.4 Prior to submitting a Bid, each Bidder shall ascertain that the Bidder has received all Addenda issued, and the Bidder shall acknowledge their receipt in the Bid.

ARTICLE 4 BIDDING PROCEDURES

§ 4.1 Preparation of Bids

§ 4.1.1 Bids shall be submitted on the forms included with or identified in the Bidding Documents.

§ 4.1.2 All blanks on the bid form shall be legibly executed. Paper bid forms shall be executed in a non-erasable medium.

§ 4.1.3 Sums shall be expressed in both words and numbers, unless noted otherwise on the bid form. In case of discrepancy, the amount entered in words shall govern.

§ 4.1.4 Edits to entries made on paper bid forms must be initialed by the signer of the Bid.

§ 4.1.5 All requested Alternates shall be bid. If no change in the Base Bid is required, enter "No Change" or as required by the bid form.

§ 4.1.6 Where two or more Bids for designated portions of the Work have been requested, the Bidder may, without forfeiture of the bid security, state the Bidder's refusal to accept award of less than the combination of Bids stipulated by the Bidder. The Bidder shall neither make additional stipulations on the bid form nor qualify the Bid in any other manner.

§ 4.1.7 Each copy of the Bid shall state the legal name and legal status of the Bidder. As part of the documentation submitted with the Bid, the Bidder shall provide evidence of its legal authority to perform the Work in the jurisdiction where the Project is located. Each copy of the Bid shall be signed by the person or persons legally authorized to bind the Bidder to a contract. A Bid by a corporation shall further name the state of incorporation and have the corporate seal affixed. A Bid submitted by an agent shall have a current power of attorney attached, certifying the agent's authority to bind the Bidder.

§ 4.1.8 A Bidder shall incur all costs associated with the preparation of its Bid.

§ 4.2 Bid Security

§ 4.2.1 Each Bid shall be accompanied by the following bid security:

(Insert the form and amount of bid security.)

§ 4.2.2 The Bidder pledges to enter into a Contract with the Owner on the terms stated in the Bid and shall, if required, furnish bonds covering the faithful performance of the Contract and payment of all obligations arising thereunder. Should the Bidder refuse to enter into such Contract or fail to furnish such bonds if required, the amount of the bid security shall be forfeited to the Owner as liquidated damages, not as a penalty. In the event the Owner fails to comply with Section 6.2, the amount of the bid security shall not be forfeited to the Owner.

§ 4.2.3 If a surety bond is required as bid security, it shall be written on AIA Document A310™, Bid Bond, unless otherwise provided in the Bidding Documents. The attorney-in-fact who executes the bond on behalf of the surety shall affix to the bond a certified and current copy of an acceptable power of attorney. The Bidder shall provide surety bonds from a company or companies lawfully authorized to issue surety bonds in the jurisdiction where the Project is located.

§ 4.2.4 The Owner will have the right to retain the bid security of Bidders to whom an award is being considered until (a) the Contract has been executed and bonds, if required, have been furnished; (b) the specified time has elapsed so that Bids may be withdrawn; or (c) all Bids have been rejected. However, if no Contract has been awarded or a Bidder has not been notified of the acceptance of its Bid, a Bidder may, beginning days after the opening of Bids, withdraw its Bid and request the return of its bid security.

§ 4.3 Submission of Bids

§ 4.3.1 A Bidder shall submit its Bid as indicated below:

(Indicate how, such as by website, host site/platform, paper copy, or other method Bidders shall submit their Bid.)

§ 4.3.2 Paper copies of the Bid, the bid security, and any other documents required to be submitted with the Bid shall be enclosed in a sealed opaque envelope. The envelope shall be addressed to the party receiving the Bids and shall be identified with the Project name, the Bidder's name and address, and, if applicable, the designated portion of the Work for which the Bid is submitted. If the Bid is sent by mail, the sealed envelope shall be enclosed in a separate mailing envelope with the notation "SEALED BID ENCLOSED" on the face thereof.

§ 4.3.3 Bids shall be submitted by the date and time and at the place indicated in the invitation to bid. Bids submitted after the date and time for receipt of Bids, or at an incorrect place, will not be accepted.

§ 4.3.4 The Bidder shall assume full responsibility for timely delivery at the location designated for receipt of Bids.

§ 4.3.5 A Bid submitted by any method other than as provided in this Section 4.3 will not be accepted.

§ 4.4 Modification or Withdrawal of Bid

§ 4.4.1 Prior to the date and time designated for receipt of Bids, a Bidder may submit a new Bid to replace a Bid previously submitted, or withdraw its Bid entirely, by notice to the party designated to receive the Bids. Such notice shall be received and duly recorded by the receiving party on or before the date and time set for receipt of Bids. The receiving party shall verify that replaced or withdrawn Bids are removed from the other submitted Bids and not considered. Notice of submission of a replacement Bid or withdrawal of a Bid shall be worded so as not to reveal the amount of the original Bid.

§ 4.4.2 Withdrawn Bids may be resubmitted up to the date and time designated for the receipt of Bids in the same format as that established in Section 4.3, provided they fully conform with these Instructions to Bidders. Bid security shall be in an amount sufficient for the Bid as resubmitted.

§ 4.4.3 After the date and time designated for receipt of Bids, a Bidder who discovers that it made a clerical error in its Bid shall notify the Architect of such error within two days, or pursuant to a timeframe specified by the law of the jurisdiction where the Project is located, requesting withdrawal of its Bid. Upon providing evidence of such error to the reasonable satisfaction of the Architect, the Bid shall be withdrawn and not resubmitted. If a Bid is withdrawn pursuant to this Section 4.4.3, the bid security will be attended to as follows:

(State the terms and conditions, such as Bid rank, for returning or retaining the bid security.)

ARTICLE 5 CONSIDERATION OF BIDS

§ 5.1 Opening of Bids

If stipulated in an advertisement or invitation to bid, or when otherwise required by law, Bids properly identified and received within the specified time limits will be publicly opened and read aloud. A summary of the Bids may be made available to Bidders.

§ 5.2 Rejection of Bids

Unless otherwise prohibited by law, the Owner shall have the right to reject any or all Bids.

§ 5.3 Acceptance of Bid (Award)

§ 5.3.1 It is the intent of the Owner to award a Contract to the lowest responsive and responsible Bidder, provided the Bid has been submitted in accordance with the requirements of the Bidding Documents. Unless otherwise prohibited by law, the Owner shall have the right to waive informalities and irregularities in a Bid received and to accept the Bid which, in the Owner's judgment, is in the Owner's best interests.

§ 5.3.2 Unless otherwise prohibited by law, the Owner shall have the right to accept Alternates in any order or combination, unless otherwise specifically provided in the Bidding Documents, and to determine the lowest responsive and responsible Bidder on the basis of the sum of the Base Bid and Alternates accepted.

ARTICLE 6 POST-BID INFORMATION

§ 6.1 Contractor's Qualification Statement

Bidders to whom award of a Contract is under consideration shall submit to the Architect, upon request and within the timeframe specified by the Architect, a properly executed AIA Document A305™, Contractor's Qualification Statement, unless such a Statement has been previously required and submitted for this Bid.

§ 6.2 Owner's Financial Capability

A Bidder to whom award of a Contract is under consideration may request in writing, fourteen days prior to the expiration of the time for withdrawal of Bids, that the Owner furnish to the Bidder reasonable evidence that financial arrangements have been made to fulfill the Owner's obligations under the Contract. The Owner shall then furnish such reasonable evidence to the Bidder no later than seven days prior to the expiration of the time for withdrawal of Bids. Unless such reasonable evidence is furnished within the allotted time, the Bidder will not be required to execute the Agreement between the Owner and Contractor.

§ 6.3 Submittals

§ 6.3.1 After notification of selection for the award of the Contract, the Bidder shall, as soon as practicable or as stipulated in the Bidding Documents, submit in writing to the Owner through the Architect:

- .1 a designation of the Work to be performed with the Bidder's own forces;
- .2 names of the principal products and systems proposed for the Work and the manufacturers and suppliers of each; and
- .3 names of persons or entities (including those who are to furnish materials or equipment fabricated to a special design) proposed for the principal portions of the Work.

§ 6.3.2 The Bidder will be required to establish to the satisfaction of the Architect and Owner the reliability and responsibility of the persons or entities proposed to furnish and perform the Work described in the Bidding Documents.

§ 6.3.3 Prior to the execution of the Contract, the Architect will notify the Bidder if either the Owner or Architect, after due investigation, has reasonable objection to a person or entity proposed by the Bidder. If the Owner or Architect has reasonable objection to a proposed person or entity, the Bidder may, at the Bidder's option, withdraw the Bid or submit an acceptable substitute person or entity. The Bidder may also submit any required adjustment in the Base Bid or Alternate Bid to account for the difference in cost occasioned by such substitution. The Owner may accept the adjusted bid price or disqualify the Bidder. In the event of either withdrawal or disqualification, bid security will not be forfeited.

§ 6.3.4 Persons and entities proposed by the Bidder and to whom the Owner and Architect have made no reasonable objection must be used on the Work for which they were proposed and shall not be changed except with the written consent of the Owner and Architect.

ARTICLE 7 PERFORMANCE BOND AND PAYMENT BOND

§ 7.1 Bond Requirements

§ 7.1.1 If stipulated in the Bidding Documents, the Bidder shall furnish bonds covering the faithful performance of the Contract and payment of all obligations arising thereunder.

§ 7.1.2 If the furnishing of such bonds is stipulated in the Bidding Documents, the cost shall be included in the Bid. If the furnishing of such bonds is required after receipt of bids and before execution of the Contract, the cost of such bonds shall be added to the Bid in determining the Contract Sum.

§ 7.1.3 The Bidder shall provide surety bonds from a company or companies lawfully authorized to issue surety bonds in the jurisdiction where the Project is located.

§ 7.1.4 Unless otherwise indicated below, the Penal Sum of the Payment and Performance Bonds shall be the amount of the Contract Sum.

(If Payment or Performance Bonds are to be in an amount other than 100% of the Contract Sum, indicate the dollar amount or percentage of the Contract Sum.)

§ 7.2 Time of Delivery and Form of Bonds

§ 7.2.1 The Bidder shall deliver the required bonds to the Owner not later than three days following the date of execution of the Contract. If the Work is to commence sooner in response to a letter of intent, the Bidder shall, prior to commencement of the Work, submit evidence satisfactory to the Owner that such bonds will be furnished and delivered in accordance with this Section 7.2.1.

§ 7.2.2 Unless otherwise provided, the bonds shall be written on AIA Document A312, Performance Bond and Payment Bond.

§ 7.2.3 The bonds shall be dated on or after the date of the Contract.

§ 7.2.4 The Bidder shall require the attorney-in-fact who executes the required bonds on behalf of the surety to affix to the bond a certified and current copy of the power of attorney.

ARTICLE 8 ENUMERATION OF THE PROPOSED CONTRACT DOCUMENTS

§ 8.1 Copies of the proposed Contract Documents have been made available to the Bidder and consist of the following documents:

- .1 AIA Document A101™–2017, Standard Form of Agreement Between Owner and Contractor, unless otherwise stated below.
(Insert the complete AIA Document number, including year, and Document title.)

- .2 AIA Document A101™–2017, Exhibit A, Insurance and Bonds, unless otherwise stated below.
(Insert the complete AIA Document number, including year, and Document title.)

- .3 AIA Document A201™–2017, General Conditions of the Contract for Construction, unless otherwise stated below.
(Insert the complete AIA Document number, including year, and Document title.)

- .4 AIA Document E203™–2013, Building Information Modeling and Digital Data Exhibit, dated as indicated below:
(Insert the date of the E203-2013.)

- .5 Drawings

Number	Title	Date	
.6	Specifications		
Section	Title	Date	Pages

.7 Addenda:

Number	Date	Pages
--------	------	-------

.8 Other Exhibits:

(Check all boxes that apply and include appropriate information identifying the exhibit where required.)

AIA Document E204™–2017, Sustainable Projects Exhibit, dated as indicated below:
(Insert the date of the E204-2017.)

The Sustainability Plan:

Title	Date	Pages
-------	------	-------

Supplementary and other Conditions of the Contract:

Document	Title	Date	Pages
----------	-------	------	-------

.9 Other documents listed below:

(List here any additional documents that are intended to form part of the Proposed Contract Documents.)

Application and Certificate for Payment

TO OWNER:	PROJECT:	APPLICATION NO: 001	Distribution to:
		PERIOD TO:	OWNER: <input type="checkbox"/>
FROM	VIA	CONTRACT FOR:	ARCHITECT: <input type="checkbox"/>
CONTRACTOR:	ARCHITECT:	CONTRACT DATE:	CONTRACTOR: <input type="checkbox"/>
		PROJECT NOS: / /	FIELD: <input type="checkbox"/>
			OTHER: <input type="checkbox"/>

CONTRACTOR'S APPLICATION FOR PAYMENT

Application is made for payment, as shown below, in connection with the Contract. Continuation Sheet, AIA Document G703, is attached.

1. ORIGINAL CONTRACT SUM	\$0.00
2. NET CHANGE BY CHANGE ORDERS	\$0.00
3. CONTRACT SUM TO DATE (Line 1 ± 2)	\$0.00
4. TOTAL COMPLETED & STORED TO DATE (Column G on G703)	\$0.00
5. RETAINAGE:	
a. 0 _____ % of Completed Work (Column D + E on G703)	\$0.00
b. 0 _____ % of Stored Material (Column F on G703)	\$0.00
Total Retainage (Lines 5a + 5b or Total in Column I of G703)	\$0.00
6. TOTAL EARNED LESS RETAINAGE	\$0.00
(Line 4 Less Line 5 Total)	
7. LESS PREVIOUS CERTIFICATES FOR PAYMENT	\$0.00
(Line 6 from prior Certificate)	
8. CURRENT PAYMENT DUE	\$0.00
9. BALANCE TO FINISH, INCLUDING RETAINAGE	
(Line 3 less Line 6)	\$0.00

CHANGE ORDER SUMMARY	ADDITIONS	DEDUCTIONS
Total changes approved in previous months by Owner	\$0.00	\$0.00
Total approved this Month	\$0.00	\$0.00
TOTALS	\$0.00	\$0.00
NET CHANGES by Change Order		\$0.00

The undersigned Contractor certifies that to the best of the Contractor's knowledge, information and belief the Work covered by this Application for Payment has been completed in accordance with the Contract Documents, that all amounts have been paid by the Contractor for Work for which previous Certificates for Payment were issued and payments received from the Owner, and that current payment shown herein is now due.

CONTRACTOR:
 By: _____ Date: _____
 State of: _____
 County of: _____
 Subscribed and sworn to before
 me this _____ day of _____

Notary Public:
 My Commission expires: _____

ARCHITECT'S CERTIFICATE FOR PAYMENT

In accordance with the Contract Documents, based on on-site observations and the data comprising this application, the Architect certifies to the Owner that to the best of the Architect's knowledge, information and belief the Work has progressed as indicated, the quality of the Work is in accordance with the Contract Documents, and the Contractor is entitled to payment of the AMOUNT CERTIFIED.

AMOUNT CERTIFIED \$0.00
(Attach explanation if amount certified differs from the amount applied. Initial all figures on this Application and on the Continuation Sheet that are changed to conform with the amount certified.)

ARCHITECT:
 By: _____ Date: _____

This Certificate is not negotiable. The AMOUNT CERTIFIED is payable only to the Contractor named herein. Issuance, payment and acceptance of payment are without prejudice to any rights of the Owner or Contractor under this Contract.



AIA[®] Document G704[™] – 2017

Certificate of Substantial Completion

PROJECT: <i>(name and address)</i>	CONTRACT INFORMATION: Contract For: Date:	CERTIFICATE INFORMATION: Certificate Number: 001 Date:
OWNER: <i>(name and address)</i>	ARCHITECT: <i>(name and address)</i>	CONTRACTOR: <i>(name and address)</i>

The Work identified below has been reviewed and found, to the Architect’s best knowledge, information, and belief, to be substantially complete. Substantial Completion is the stage in the progress of the Work when the Work or designated portion is sufficiently complete in accordance with the Contract Documents so that the Owner can occupy or utilize the Work for its intended use. The date of Substantial Completion of the Project or portion designated below is the date established by this Certificate.
(Identify the Work, or portion thereof, that is substantially complete.)

ARCHITECT <i>(Firm Name)</i>	SIGNATURE	PRINTED NAME AND TITLE	DATE OF SUBSTANTIAL COMPLETION
-------------------------------------	------------------	-------------------------------	---------------------------------------

WARRANTIES

The date of Substantial Completion of the Project or portion designated above is also the date of commencement of applicable warranties required by the Contract Documents, except as stated below:
(Identify warranties that do not commence on the date of Substantial Completion, if any, and indicate their date of commencement.)

WORK TO BE COMPLETED OR CORRECTED

A list of items to be completed or corrected is attached hereto, or transmitted as agreed upon by the parties, and identified as follows:
(Identify the list of Work to be completed or corrected.)

The failure to include any items on such list does not alter the responsibility of the Contractor to complete all Work in accordance with the Contract Documents. Unless otherwise agreed to in writing, the date of commencement of warranties for items on the attached list will be the date of issuance of the final Certificate of Payment or the date of final payment, whichever occurs first. The Contractor will complete or correct the Work on the list of items attached hereto within () days from the above date of Substantial Completion.

Cost estimate of Work to be completed or corrected: \$

The responsibilities of the Owner and Contractor for security, maintenance, heat, utilities, damage to the Work, insurance, and other items identified below shall be as follows:
(Note: Owner’s and Contractor’s legal and insurance counsel should review insurance requirements and coverage.)

The Owner and Contractor hereby accept the responsibilities assigned to them in this Certificate of Substantial Completion:

CONTRACTOR <i>(Firm Name)</i>	SIGNATURE	PRINTED NAME AND TITLE	DATE
OWNER <i>(Firm Name)</i>	SIGNATURE	PRINTED NAME AND TITLE	DATE



AIA[®] Document G706A[™] – 1994

Contractor's Affidavit of Release of Liens

PROJECT: <i>(Name and address)</i>	ARCHITECT'S PROJECT NUMBER:	OWNER: <input type="checkbox"/>
TO OWNER: <i>(Name and address)</i>	CONTRACT FOR:	ARCHITECT: <input type="checkbox"/>
	CONTRACT DATED:	CONTRACTOR: <input type="checkbox"/>
		SURETY: <input type="checkbox"/>
		OTHER: <input type="checkbox"/>

STATE OF:
COUNTY OF:

The undersigned hereby certifies that to the best of the undersigned's knowledge, information and belief, except as listed below, the Releases or Waivers of Lien attached hereto include the Contractor, all Subcontractors, all suppliers of materials and equipment, and all performers of Work, labor or services who have or may have liens or encumbrances or the right to assert liens or encumbrances against any property of the Owner arising in any manner out of the performance of the Contract referenced above.

EXCEPTIONS:

SUPPORTING DOCUMENTS ATTACHED HERETO:

1. Contractor's Release or Waiver of Liens, conditional upon receipt of final payment.
2. Separate Releases or Waivers of Liens from Subcontractors and material and equipment suppliers, to the extent required by the Owner, accompanied by a list thereof.

CONTRACTOR: *(Name and address)*

BY: _____
(Signature of authorized representative)

(Printed name and title)

Subscribed and sworn to before me on this date:

Notary Public:
My Commission Expires:



AIA[®] Document G707[™] – 1994

Consent Of Surety to Final Payment

PROJECT: <i>(Name and address)</i>	ARCHITECT'S PROJECT NUMBER:	OWNER: <input type="checkbox"/>
	CONTRACT FOR:	ARCHITECT: <input type="checkbox"/>
TO OWNER: <i>(Name and address)</i>	CONTRACT DATED:	CONTRACTOR: <input type="checkbox"/>
		SURETY: <input type="checkbox"/>
		OTHER: <input type="checkbox"/>

In accordance with the provisions of the Contract between the Owner and the Contractor as indicated above, the
(Insert name and address of Surety)

on bond of
(Insert name and address of Contractor)

, SURETY,

hereby approves of the final payment to the Contractor, and agrees that final payment to the Contractor shall
not relieve the Surety of any of its obligations to
(Insert name and address of Owner)

, CONTRACTOR,

as set forth in said Surety's bond.

, OWNER,

IN WITNESS WHEREOF, the Surety has hereunto set its hand on this date:
(Insert in writing the month followed by the numeric date and year.)

(Surety)

(Signature of authorized representative)

(Printed name and title)

Attest:
(Seal):

SECTION 00730 - SUPPLEMENTARY GENERAL CONDITIONS

The Supplementary General Conditions hereinafter described contain changes and additions to the AIA General Conditions Document A201, Fifteenth Edition, 1997. Where any part of the AIA General Conditions is not modified or voided by these Supplementary General Conditions, the unaltered provisions shall remain in effect.

These Supplementary Conditions shall be read with and as complementary to the General Conditions and in the event of conflict, the Supplementary General Conditions shall govern.

The Articles of the Supplementary Conditions use Articles, Number and Titles which relate to the General Conditions of the Contract. As an example, 1.2.3.4. refers to an Article, Paragraph, Subparagraph and Clause of the General Conditions.

Reference to Division 1

Provisions of the General Conditions pertaining to work related, administrative and procedural matters, i.e., Alternates, Construction phasing, Shop Drawing submittals, Temporary Facilities, etc., are referenced in these Supplementary Conditions to those applicable Sections of Division 1 - General Requirements.

ARTICLE 1 BASIC REQUIREMENTS

1.1.1 THE CONTRACT DOCUMENTS

Add the following to line 3 after the words "...drawings, specifications,": "...project manual,..."

Add the following to line 8 after the words "...such as": "...shop drawings, product submittals..."

Add the following at the end of the paragraph: "Architect or Owner review of shop drawings and submittals does not constitute a Modification of the Contract."

1.1.3 THE WORK

Add the following:

The terms "furnish," "install," "provide" or equivalent works as used in the Contract Documents, without further limitations, shall be construed to mean the responsibility to furnish and completely install the device, equipment, or material named, together with all associated devices, equipment, materials, wiring, piping, etc., as may be required for a complete and operating installation.

Where materials, systems and equipment items are referred to in the singular, such reference shall not serve to limit the quantity required. Furnish quantities as required by the Contract Documents to complete the work.

1.2 CORRELATION AND INTENT OF THE CONTRACT DOCUMENTS

1.2.2 Add the following:

"The Contractor is responsible for assignment of work divisions, for definition of limits of scope of each subcontract or trade, and for all subcontractual divisions of the Work. Use by the Contractor of specification section reference for Contractor's convenience in subdivision of the Work shall in no way obligate Owner, Architect or their consultants to render interpretations or

decisions, nor to enter nor to be joined in arbitration pertaining to Contractor's use of specification section references."

1.6.1.1 Release of Electronic Media Drawings Files: An agreement titled "Agreement Concerning Drawing Files on Electronic Media" must be signed and returned to the Architecture prior to release of any documents. A copy of the release shall be available from the Architect.

1.2.1 Add the following: Where a conflict exists in the contract documents, the more restrictive requirement shall apply.

ARTICLE 2 OWNER

2.4 OWNER'S RIGHT TO CARRY OUT THE WORK

2.4.1 Delete the word "**approval**" in the second to the last sentence and substitute the word "**review**."

ARTICLE 3 CONTRACTOR

3.5 WARRANTY

Add the following to paragraph 3.5.1

"The Contractor shall secure all written guarantees and/or warranties required by the Specifications. The Contractor is responsible for the warranty of the entire work of his Contract."

3.7.1.1 Add the following

A. ON SITE:

Fees: All impact fees, permits etc. on the school site will be the responsibility of the school district

B. OFF SITE/ROADWAYS:

Fees: All impact fees, permits etc., of the school site will be the responsibility of the Contractor

3.10 CONTRACTOR'S CONSTRUCTION SCHEDULES

3.10.1 Add the following before the word "shall" on line 1:

"...and prior to the first Application for Payment..."

Add the following after the word "Work" on line 2:

"...that shall identify commencement and completion dates for each portion of the Work listed in the schedule of values required in subparagraph 9.2.1."

3.12 SHOP DRAWINGS, PRODUCT DATA AND SAMPLES

3.12.8 Delete the word Architects "**approval**" in 3 locations and substitute the word Architects "**review**" in all instances.

ARTICLE 4 ADMINISTRATION OF THE CONTRACT

4.2 ARCHITECT'S ADMINISTRATION OF THE CONTRACT

4.2.4 Add the following at the end of the paragraph: "Copies of all written communication between Owner and Contractor, subcontractors or material suppliers shall be sent to the Architect as a part of initial distribution of these communications."

4.2.7 Delete the words "and approve" in the second sentence.

Delete the words "as to cause no delay" in the line 5.

At the end of the second sentence, add the following:

"The reasonable time for review of or response to submittals shall be not less than five (5) working days, or more than ten (10) working days, unless defined otherwise by Division 1 specifications. Contractor shall prepare and submit all items for Architect's review so as to cause no delay when in conformance with the submittal schedule required in subparagraph 3.10.2."

Delete the words "approval" in the last sentence and substitute the word "review."

4.2.9 Delete the word "inspections" from line 1 and substitute the words "site reviews."

4.6 ARBITRATION

4.6.2 Delete the word "shall" from line 1 and substitute the word "may."

ARTICLE 5 SUBCONTRACTORS:

5.2 AWARD OF SUBCONTRACTS AND OTHER CONTRACTS FOR PORTIONS OF THE WORK

5.2.1 Insert the following into line 2 after the word "after:" "Bid Opening, but in no case later than two working days after..."

5.3 SUBCONTRACTUAL RELATIONS

5.3.2 Add the following:

"Each agreement between the Contractor and his various Subcontractors shall be amended as follows:

1. That the work required to be performed under this Agreement shall not be started, nor shall the Contractor cause said work to be started, until the following conditions have been satisfactorily met.
 - A. All surfaces, project conditions, locations and work of other trades against which, over which, on which or adjacent to which this Subcontractor's work is to be installed shall be thoroughly inspected by affected craftsmen.
 - B. This Subcontractor shall immediately report, in detail and in writing, to the Contractor

any and all conditions observed during said inspection which may tend to contribute to an unsatisfactory installation or application of the Work required hereunder.

C. The Contractor and the Subcontractor, as principal parties to this Agreement, thereby agree that no work shall be started, installed, applied or completed on, over or against objectionable surfaces or conditions until said objectionable surfaces or conditions have been satisfactorily corrected by the Contractor or the trade responsible therefore.

2. That in case of inability to agree on the required correction or on disputed surfaces or conditions, both parties hereto agree to submit said dispute or disagreement to the Architect for final and mutually binding judgment.”

ARTICLE 7 CHANGES IN THE WORK:

7.1.4 Add the following:

The allowance for the combined overhead and profit and related bond costs, included in the Total cost to the Owner shall be limited to the following schedule:

1. For the Contractor, for Work performed by the Contractor's own forces, 10 percent of the cost.
2. For the Contractor, for Work performed by the Contractor's Subcontractor, 5 percent of the amount due the Subcontractor.
3. For each Subcontractor or Sub-subcontractor involved, for Work performed by that Subcontractor or Sub-subcontractor's own forces, 10 percent of the cost.
4. For each subcontractor, for Work performed by the subcontractor's sub-subcontractors, 5 percent of the amount due the sub-subcontractor.
5. Cost to which overhead and profit is to be applied shall be determined in accordance with Subparagraph 7.3.6
6. In order to facilitate checking of quotations for extras or credits, all proposals, except those so minor that their propriety can be seen by inspection, shall be accompanied by a complete itemization of cost including labor, materials and Subcontracts. Labor and materials shall be itemized in the manner prescribed above. Where major cast items are subcontracts, they shall be itemized also.

ARTICLE 8 TIME:

8.1 DEFINITIONS

8.1.4 Add the following:

“In this Contract, the term DAY shall mean a calendar day of 24 Hours beginning at 12:00 midnight. The WORKING DAY shall mean any calendar day except Saturday, Sunday and legal holidays at the place of building.”

8.2 PROGRESS AND COMPLETION

8.2.3 Add the following:

“Contractor shall expeditiously commence the Work within ten (10) working days following and after written Notice to Proceed, from the Owner, and shall substantially complete all Work included in this Contract in a manner satisfactory to the Owner in the number of days or by the date specified in the Bid Form. The Contractor agrees that for each and every day any portion

of the Work remains unfinished after the time herein fixed or extended by the owner for its completion, the Owner shall deduct and retain out of the money which may be due or become due said Contractor under this agreement, the sums for liquidated compensatory damages shall be One Thousand Dollars (\$1,000.00) Per Day.

ARTICLE 9 PAYMENTS AND COMPLETION:

9.2 SCHEDULE OF VALUES

9.2.1 Add the following after the word "Work," on line 2: "correlated to the Contractor's construction schedule, as reviewed by Architect and Owner and adjusted to their instructions."

9.3 APPLICATIONS FOR PAYMENT

9.3.1 Add the following sentence:

"In making such progress payments, there shall be retained five percent (5%) of the requested amount until Substantial Completion of the entire work."

9.3.1.1 Add the word "not" after the word "may" on line 1.

9.3.2 Add the following to line 2 after the word "site": "..., subject to the review of the Owner and Architect,"

9.10 FINAL COMPLETION AND FINAL PAYMENT:

9.10.1 Delete the word "**Inspection**" at 3 locations, and substitute the words "**site review.**"

ARTICLE 10 PROTECTION OF PERSONS AND PROPERTY:

10.2 SAFETY OF PERSONS AND PROPERTY

10.2.6 Add the following:

"Contractor shall institute a safety program at the start of construction to minimize accidents, such program shall continue to the end of the job and conform to the latest general safety orders of the State Industrial Commission as contained in the State Occupational Safety and Health Act. The manual of Accident Prevention in Construction may be used as a guideline for safety practices.

The presence of an observer or other persons representing the Owner and/or the Architect and/or his representative shall not in any way be construed as to limit the Contractor's full responsibility for safety of all persons on the premises."

ARTICLE 11 INSURANCE AND BONDS:

11.1.1 Insert the following phrase after "companies" in line 1, but before word "lawfully" in line 1: "...rated A- or better by the A.M. Best Company and..."

11.1.2 Delete the provisions in its entirety and substitute the following provisions:

“The insurance required in subparagraph 11.1.1.2, 11.1.1.3, and 11.1.1.4 shall be written for not less than the limits specified below. The general liability coverage specified in 11.1.1.3 and 11.1.1.4 may be written on either a ‘Comprehensive General Liability Coverage Form’ or a ‘Commercial General Liability Coverage Form’ provided the limits and coverage comply with that specified below under subparagraph 11.1.2.3. Coverage under either the ‘Comprehensive General Liability Insurance’ policy form or ‘Commercial General Liability Coverage Form’ may be written on a ‘claims made’ basis provided all certificates of insurance so state and continuous coverage is maintained for three years after the date of substantial completion or an extended discovery endorsement is provided.”

11.1.2.1 Worker’s Compensation as required by subparagraph 11.1.1 shall provide the following coverage limits:

- a. State statutory limits.
- b. Applicable federal requirements, if applicable.
- c. Employers liability: \$1,000,000.00.

11.1.2.2 Comprehensive Automobile Liability as required by subparagraph 11.1.1.6 shall provide the following limits and include coverage for all owned, hired and non-owned vehicles:

- a. A combined single limit of \$1,000,000 each occurrence for bodily injury or split limits of \$1,000,000 per person, \$1,000,000 each occurrence for bodily injury and \$1,000,000 for property damage.
- b. No fault automobile coverage for the State where the project is located, if applicable.

11.1.2.3 General Liability Insurance as required by 11.1.1.3, 11.1.1.4, 11.1.1.5, and 11.1.1.7 shall provide the following limits and coverage. Coverage may be written by either a “Comprehensive General Liability Insurance” policy form, in which case subparagraph “a” applies, or, a “Commercial General Liability Coverage” policy form in which case subparagraph “b” applies.

- a. Comprehensive General Liability Insurance including coverage for premises-operations, independent contractors, products and completed operations, personal injury liability with employment exclusion deleted, blanket contractual, broad from property damage, “X”, “C”, and “U” exclusions deleted. Combined single limits of \$1,000,000 each occurrence, \$1,000,000 aggregate.
- b. Commercial General Liability coverage form including coverage for premises-operations, independent contractors and products and completed operations with no exclusions applicable to the contractual obligations assumed under paragraph 3.18.

Limits of coverage as follows:

- \$2,000,000 General aggregate limit.
- \$1,000,000 Products-completed operations aggregate.
- \$1,000,000 Each occurrence (bodily injury or property damage combined).

11.1.2.4. Excess or Umbrella Liability insurance with limits applying in addition to the primary limits specified above for Commercial General Liability Insurance, Commercial Automobile Liability Insurance, Employee Liability Insurance. The policy may be written on either an Excess or

Umbrella form with aggregate limits of at least \$1,000,000.

11.1.3 Delete phrase “and are reasonably available” from the second sentence.

11.2 OWNER'S LIABILITY INSURANCE

11.2.1 Delete paragraph in its entirety and replace by the following:

“The Owner and Architect shall be named as ‘additional insures’ on the ‘Comprehensive General Liability Insurance’ or ‘Commercial General Liability Coverage’ maintained by the Contractor as required under paragraph 11.1.2.3.”

11.4 PROPERTY INSURANCE

11.4.1 Delete the phrase “without optional deductibles” from line 6.

Delete the last sentence and substitute the following as the last sentence in paragraph:

“This insurance shall include as additional insures the Contractor, subcontractors, sub-subcontractors in the Work, the Architect, and all consultants in order to properly protect each party’s interest in the project.”

11.4.1.2 Add the phrase “Architect and all consultants” after “sub-subcontractors in the work” on line 5.

11.4.1.3 Add the following after the end of subparagraph:

“The deductible shall be \$5,000.00 per claim; Contractor shall pay the deductible.”

11.4.1.4 Delete entire paragraph and substitute the following:

“Unless otherwise provided in the contract documents, the property insurance provided by the Owner will cover materials and portions of the work stored on the project site, but not yet installed in the building or structure. The Contractor shall be responsible to provide property insurance for all risks of physical loss including theft for portions of the work stored off the project site or in transit, regardless of Owner’s title as outlined in paragraph 9.3.2. In the event Contractor fails to maintain the required insurance for materials stored off site and in transit, he shall bear financial responsibility for the full replacement cost of any loss.

11.5 PERFORMANCE BOND AND PAYMENT BOND

11.5.1 Add the following:

“Simultaneously with his delivery of the executed contract, the General Contractor shall furnish Performance Bond and Labor and Material Payment Bond forms executed on current AIA Document A312, a copy of which is bound herein, with amount shown on each part to 100% of the total amount payable by terms of the Contract or Sub-Contract. Surety shall be a company licensed to do business in the same locality as the project and shall be acceptable to the Owner.

ARTICLE 12 UNCOVERING AND CORRECTION OF WORK:

12.3 ACCEPTANCE OF NONCONFORMING WORK

12.3.1 Add the following:

“No work, which may be defective in its construction, or deficient in any way of the requirements of these Specifications, will be considered as accepted in consequence of the failure of the inspector connected with the Work, to point out said defects or deficiencies during construction, and the Contractor shall correct any imperfect Work, whenever discovered, before the final acceptance of the Work by the Owner, and all Work done shall be subject to the guarantee as set forth in the Agreement and Bond.”

ARTICLE 13 MISCELLANEOUS PROVISIONS:

13.1 GOVERNING LAW

13.1.1 Add the following:

“The Contractor shall observe all “City and County Ordinances” that in any way affect the operations required in the construction of Work herein contemplated. No equipment shall be used on street or roadway rights-of-way that are equipped with cleats or other injurious parts that may cause damage. No traffic, street or control signs shall be removed until sanctioned by the City Engineer, and the Contractor shall assume and be responsible for accident or damage for failure to comply with the above instructions.”

13.8 ADDITIONAL RESPONSIBILITIES

13.8.1 Add the following:

“Temporary Signs:

Signs or advertisements shall not be permitted to be displayed without review of Architect.

13.8.2 Definition of Owner’s (Project) Representative:

The terms “Owner’s Representative” and “Owner’s Project Representative” shall be defined hereby as the person who is authorized to act on behalf of the entity identified as “Owner” in the Agreement between the Owner and Contractor. These terms shall be considered as equal and interchangeable throughout these Contract Documents.

13.8.3 Contractor’s Responsibilities:

The Contractor shall employ a licensed Surveyor satisfactory to the Owner and reporting certifications to the Owner, to establish location and lines of building and finish floor elevations.

The Contractor shall establish all property lines, restrictions, bench marks, grades, lines and levels as required, and he shall maintain and be responsible for same.

Contractor shall verify existing grades, lines, levels and dimensions as shown on drawings and shall report any errors, inconsistencies, or variations in above to Owner’s Project Representative before commencing work. At any time Contractor learns of any said error, inconsistency or variation he shall immediately report the same to Owner’s Project Representative before proceeding any further with the Work.

The Contractor shall provide and maintain well-built batter boards at corners; establish and

safeguard bench marks in at least 2 widely separated places; as work progresses, establish bench marks at each level; give exact location of partitions as guide to grades. The Contractor shall use extreme care that building to be erected does not encroach upon any adjoining property and also does not violate any zoning or set-back restrictions, and shall indemnify the Owner from any cost and damage in case of such encroachment or violation.

The Contractor shall, throughout the entire construction period, effectively control dust at the working area, on unpaved roads used in the operations, and on involved portions of the site, as may be required to keep the dust to a minimum. Such dust control shall include intermittent watering and sprinkling at such a frequency as will satisfactorily allay the dust.

END OF SECTION

SECTION 011000 - SUMMARY**PART 1 - GENERAL****1.1 RELATED DOCUMENTS**

- A. Drawings and general provisions of the Contract, including General and Supplementary Conditions and other Division 1 Specification Sections, apply to this Section.

1.2 SUMMARY

- A. This Section includes the following:
 - 1. Work covered by the Contract Documents.
 - 2. Type of the Contract.
 - 3. Use of premises.
 - 4. Code compliance
 - 5. Dust control

1.3 WORK COVERED BY CONTRACT DOCUMENTS

- A. Project Identification: Highland Jr. High School – Kitchen Remodel
 - 1. Project Location: 325 Gramercy Ave., Ogden, UT 84404
- B. Owner: Ogden School District
 - 1. Owner's Representative: Ken Crawford, Support Services, Ogden School District
- C. Architect: NJRA Architects, 5272 S. College Dr., Ste. 104, Murray, Utah 84123
 - 1. Project Manager: Zeke Zenger
- D. The Work consists of the following:
 - 1. Remove existing walls & floors as indicated on drawings.
 - 2. Remove existing windows & doors as indicated on drawings.
 - 3. Provide new floor drains & floor sinks with new sewer lines as indicated on drawings.
 - 4. Cut & patch concrete slab on grade as required for new sewer lines.
 - 5. Replace existing floor with new tiles as indicated on drawings.
 - 6. Build new walls, wainscot, ceiling, windows, doors, countertop, lockers, etc. as indicated on drawings.
 - 7. Repair dock & exterior walls as indicated on drawings.
 - 8. Provide new kitchen services & equipment.
 - 9. Provide new structure.
 - 10. Provide new HVAC & plumbing services & equipment.
 - 11. Provide new electrical services & equipment.

1.4 TYPE OF CONTRACT

- A. Project will be constructed under a single prime contract.

1.5 USE OF PREMISES

- A. General: Contractor shall have full use of the premises (building and site) for construction operations to the extent that is indicated on the floor plans. Use of premises shall be allowed during the construction period only, unless authorized and coordinated by the owner's representative.

1.6 CODE COMPLIANCE

- A. All work shall comply with current edition of codes including but not limited to the following:
1. International Building Code
 2. International Mechanical Code
 3. International Plumbing Code
 4. NFPA
 5. National Electric Code
 6. OSHA Regulation
 7. Health and Safety Regulations
 8. Utility Company Regulations
 9. Police, Fire Department Rules
 10. Environmental Protection Regulations
 11. Americans with Disabilities Act
- B. Arrange for authorities having jurisdiction to inspect and test according to their requirements and for each temporary utility before use. Obtain required certifications and permits.
- C. Requirements of codes and regulations shall be considered as the minimum. Where the contract documents exceed (without violating) code and regulation requirements, contract requirements shall take precedence. Where codes conflict, the more stringent shall apply.

1.6 DUST CONTROL

- A. The Contractor shall be responsible to provide continuous (7 days per week, 24 hours per day) fugitive dust control measures within the limits of the construction area. Dust control shall be provided for, but not be specifically limited to, existing areas of the building which are not directly involved in the construction activities or are occupied by people or equipment. It shall also include haul roads, access roads, excavations, and all other areas which become potential sources of dust as a result of construction activities.
- B. Contractor's dust control measures shall maintain compliance with the General Utah Air Pollution Regulations, R446 – Utah Conservation Regulations, Section 4.5, Fugitive Emissions, and as directed by the Owner's Representative and the Architect. Dust control measures shall include but not be limited to the following:
1. Wetting of surfaces with water as appropriate.
 2. Minimizing surface disturbance.

PART 2 - PRODUCTS (Not Used)

PART 3 - EXECUTION (Not Used)

END OF SECTION 011000

SECTION 012100 - ALLOWANCES

PART 1 - GENERAL

1.1 RELATED DOCUMENTS

- A. Drawings and general provisions of the Contract, including General and Supplementary Conditions and other Division 1 Specification Sections, apply to this Section.

1.2 SUMMARY

- A. This Section includes administrative and procedural requirements governing allowances.
 - 1. Certain items are specified in the Contract Documents by allowances. Allowances have been established in lieu of additional requirements and to defer selection of actual materials and equipment to a later date when additional information is available for evaluation. If necessary, additional requirements will be issued by Change Order.
- B. Types of allowances include the following:
 - 1. Lump-sum allowances.

1.3 SUBMITTALS

- A. Coordinate and process submittals for allowance items in same manner as for other portions of the Work.

1.4 COORDINATION

- A. Coordinate allowance items with other portions of the Work. Furnish templates as required to coordinate installation.

1.5 CONTINGENCY ALLOWANCES

- A. Use the contingency allowance only as directed by Architect for Owner's purposes. All amounts that are to be charged to the allowance shall be documented by the architect.
- B. The General Contractor's overhead, profit, and related costs for products and equipment that are to be billed to the contingency allowance are included in the contract sum and shall not be added to proposed scope change. It is acceptable for subcontractors to add profit and overhead on changes that are to be charged to the allowance.
- C. **Contingency Allowance: \$50,000**
- D. At Project closeout, credit unused amounts remaining in the contingency allowance to Owner by Change Order.

PART 2 - PRODUCTS (Not Used)

PART 3 - EXECUTION

3.1 EXAMINATION

- A. Examine products covered by an allowance promptly on delivery for damage or defects. Return damaged or defective products to manufacturer for replacement.

3.2 PREPARATION

- A. Coordinate materials and their installation for each allowance with related materials and installations to ensure that each allowance item is completely integrated and interfaced with related work.

END OF SECTION 012100

SECTION 012900 - PAYMENT PROCEDURES**PART 1 - GENERAL****1.1 RELATED DOCUMENTS**

- A. Drawings and general provisions of the Contract, including General and Supplementary Conditions and other Division 1 Specification Sections, apply to this Section.

1.2 SUMMARY

- A. This Section specifies administrative and procedural requirements necessary to prepare and process Applications for Payment.

1.3 DEFINITIONS

- A. Schedule of Values: A statement furnished by Contractor allocating portions of the Contract Sum to various portions of the Work and used as the basis for reviewing Contractor's Applications for Payment.

1.4 SCHEDULE OF VALUES

- A. Coordination: Coordinate preparation of the Schedule of Values with preparation of Contractor's Construction Schedule.
 - 1. Correlate line items in the Schedule of Values with other required administrative forms and schedules, including the following:
 - a. Application for Payment forms with Continuation Sheets.
- B. Format and Content: Use the Project Manual table of contents as a guide to establish line items for the Schedule of Values. Provide at least one line item for each Specification Section.
 - 1. Identification: Include the following Project identification on the Schedule of Values:
 - a. Project name and location.
 - b. Name of Architect.
 - c. Architect's project number.
 - d. Contractor's name and address.
 - e. Date of submittal.
 - 2. Submit draft of AIA Document G703 Continuation Sheets.

1.5 APPLICATIONS FOR PAYMENT

- A. Each Application for Payment shall be consistent with previous applications and payments as certified by Architect and paid for by Owner.
 - 1. Initial Application for Payment, Application for Payment at time of Substantial Completion, and final Application for Payment involve additional requirements.
- B. Payment Application Times: Progress payments shall be submitted to Architect by the 10th of the month. The period covered by each Application for Payment is one month, ending on the last day of the month.
- C. Payment Application Forms: Use AIA Document G702 and AIA Document G703 Continuation Sheets as form for Applications for Payment.

- D. Application Preparation: Complete every entry on form. Notarize and execute by a person authorized to sign legal documents on behalf of Contractor. Architect will return incomplete applications without action.
1. Entries shall match data on the Schedule of Values and Contractor's Construction Schedule. Use updated schedules if revisions were made.
 2. Include amounts of Change Orders and Construction Change Directives issued before last day of construction period covered by application.
- E. Transmittal: Submit 3 signed and notarized original copies of each Application for Payment to Architect. One copy shall include waivers of lien and similar attachments if required.
1. Transmit each copy with a transmittal form listing attachments and recording appropriate information about application.
- F. Initial Application for Payment: Administrative actions and submittals that must precede or coincide with submittal of first Application for Payment include the following:
1. Contractor's Construction Schedule (preliminary if not final).
 2. Submittals Schedule (preliminary if not final).
- G. Application for Payment at Substantial Completion: After issuing the Certificate of Substantial Completion, submit an Application for Payment showing 100 percent completion for portion of the Work claimed as substantially complete.
1. Include documentation supporting claim that the Work is substantially complete and a statement showing an accounting of changes to the Contract Sum.
- H. Final Payment Application: Submit final Application for Payment with releases and supporting documentation not previously submitted and accepted, including, but not limited, to the following:
1. Evidence of completion of Project closeout requirements.
 2. Updated final statement, accounting for final changes to the Contract Sum.
 3. AIA Document G707, "Consent of Surety to Final Payment."

PART 2 - PRODUCTS (Not Used)

PART 3 - EXECUTION (Not Used)

END OF SECTION 012900

SECTION 013100 - PROJECT MANAGEMENT AND COORDINATION

PART 1 - GENERAL

1.1 RELATED DOCUMENTS

- A. Drawings and general provisions of the Contract, including General and Supplementary Conditions and other Division 01 Specification Sections, apply to this Section.

1.2 SUMMARY

- A. This Section includes administrative provisions for coordinating construction operations on Project including, but not limited to, the following:
 - 1. Administrative and supervisory personnel.
 - 2. Project meetings.

1.3 COORDINATION

- A. Coordination: Coordinate construction operations included in different Sections of the Specifications to ensure efficient and orderly installation of each part of the Work. Coordinate construction operations, included in different sections that depend on each other for proper installation, connection, and operation.
 - 1. Schedule construction operations in sequence required to obtain the best results where installation of one part of the Work depends on installation of other components, before or after its own installation.
- B. Administrative Procedures: Coordinate scheduling and timing of required administrative procedures with other construction activities and activities of other contractors to avoid conflicts and to ensure orderly progress of the Work. Such administrative activities include, but are not limited to, the following:
 - 1. Preparation of Contractor's Construction Schedule.
 - 2. Delivery and processing of submittals.
 - 3. Progress meetings.
 - 4. Preinstallation conferences.
 - 5. Project closeout activities.
 - 6. Startup and adjustment of systems.

1.4 SUBMITTALS

- A. Key Personnel Names: Within 30 days of starting construction operations, submit a list of key personnel assignments, including superintendent and other personnel in attendance at Project site. Identify individuals and their duties and responsibilities; list addresses and telephone numbers, including home and office telephone numbers. Provide names, addresses, and telephone numbers of individuals assigned as standbys in the absence of individuals assigned to Project.

PART 2 - PRODUCTS (Not Used)

PART 3 - EXECUTION (Not Used)

END OF SECTION 013100

SECTION 013300 - SUBMITTAL PROCEDURES

PART 1 - GENERAL

1.1 RELATED DOCUMENTS

- A. Drawings and general provisions of the Contract, including General and Supplementary Conditions and other Division 1 Specification Sections, apply to this Section.

1.2 SUMMARY

- A. This Section includes administrative and procedural requirements for submitting Shop Drawings, Product Data, Samples, and other submittals.

1.3 SUBMITTAL PROCEDURES

- A. General: Electronic copies of CAD Drawings of the Contract Drawings will not be provided by Architect for Contractor's use in preparing submittals.
- B. Coordination: Coordinate preparation and processing of submittals with performance of construction activities.
- C. Submittals Schedule: Comply with requirements in Division 1 Section "Construction Progress Documentation" for list of submittals and time requirements for scheduled performance of related construction activities.
- D. Processing Time: Allow enough time for submittal review, including time for resubmittals, as follows. Time for review shall commence on Architect's receipt of submittal. No extension of the Contract Time will be authorized because of failure to transmit submittals enough in advance of the Work to permit processing, including resubmittals.
 - 1. Initial Review: Allow 10 days for initial review of each submittal. Allow additional time if coordination with subsequent submittals is required. Architect will advise Contractor when a submittal being processed must be delayed for coordination.
 - 2. Resubmittal Review: Allow 10 days for review of each resubmittal.
- E. Identification: Place a permanent label or title block on each submittal for identification.
 - 1. Indicate name of firm or entity that prepared each submittal on label or title block.
 - 2. Include the following information on label for processing and recording action taken:
 - a. Project name.
 - b. Date.
 - c. Name and address of Architect.
 - d. Name and address of Contractor.
 - e. Name and address of subcontractor.
 - f. Name and address of supplier.
 - g. Name of manufacturer.
 - h. Submittal number or other unique identifier, including revision identifier.
 - i. Number and title of appropriate Specification Section.

- j. Drawing number and detail references, as appropriate.
 - k. Location(s) where product is to be installed, as appropriate.
- F. Transmittal: Package each submittal individually and appropriately for transmittal and handling. Transmit each submittal using a transmittal form.
- G. Distribution: Furnish copies of final submittals to manufacturers, subcontractors, suppliers, fabricators, installers, authorities having jurisdiction, and others as necessary for performance of construction activities.
- 1. Use for Construction: Use only final submittals with mark indicating "Approval notation from Architect's action stamp".

PART 2 - PRODUCTS

2.1 ACTION SUBMITTALS

- A. General: Prepare and submit Action Submittals required by individual Specification Sections.
- B. Submittals Schedule: Contractor shall process all Project submittals including Samples for Initial Selection as described herein and deliver to architect within 60 days after the date of Notice to Proceed or 60 days after date of the Preconstruction Conference and Commencement of Construction Activities, whichever occurs earlier. The Contractor shall pay directly to the Owner a penalty of \$100 for each submittal for every calendar day after the sixty days have elapsed.
- C. Product Data: Collect information into a single submittal for each element of construction and type of product or equipment.
- 1. Mark each copy of each submittal to show which products and options are applicable.
 - 2. Include the following information, as applicable:
 - a. Manufacturer's written recommendations.
 - b. Manufacturer's product specifications.
 - c. Manufacturer's installation instructions.
 - d. Standard color charts.
 - e. Manufacturer's catalog cuts.
 - f. Standard product operation and maintenance manuals.
 - g. Compliance with specified referenced standards.
 - 3. Submit Product Data concurrent with Samples.
 - 4. Number of Copies: Submit electronically whenever possible. If electronic submittal is not possible, submit four copies of Product Data, unless otherwise indicated.
- D. Shop Drawings: Prepare Project-specific information, drawn accurately to scale. Do not base Shop Drawings on reproductions of the Contract Documents or standard printed data.
- 1. Preparation: Fully illustrate requirements in the Contract Documents. Include the following information, as applicable:
 - a. Dimensions.
 - b. Identification of products.
 - c. Fabrication and installation drawings.
 - d. Roughing-in and setting diagrams.

- e. Wiring diagrams showing field-installed wiring, including power, signal, and control wiring.
 - f. Shopwork manufacturing instructions.
 - g. Schedules.
 - h. Design calculations.
 - i. Compliance with specified standards.
 - j. Relationship to adjoining construction clearly indicated.
2. Sheet Size: Except for templates, patterns, and similar full-size drawings, submit Shop Drawings on sheets at least 8-1/2 by 11 inches (215 by 280 mm) but no larger than 30 by 42 inches (750 by 1000 mm).
 3. Number of Copies: Submit electronically whenever possible. If electronic submittal is not possible, submit four copies of Shop Drawings, unless otherwise indicated.
- E. Samples: Submit Samples for review of kind, color, pattern, and texture for a check of these characteristics with other elements and for a comparison of these characteristics between submittal and actual component as delivered and installed.
1. Samples for Initial Selection: Submit manufacturer's color charts consisting of units or sections of units showing the full range of colors, textures, and patterns available.
 - a. Number of Samples: Submit one full set of available choices where color, pattern, texture, or similar characteristics are required to be selected from manufacturer's product line. Architect will return submittal with options selected.

2.2 INFORMATIONAL SUBMITTALS

- A. General: Prepare and submit Informational Submittals required by other Specification Sections.
1. Number of Copies: Submit electronically whenever possible. If not possible, submit Four copies of each submittal, unless otherwise indicated.
 2. Certificates and Certifications: Provide a notarized statement that includes signature of Contractor, testing agency, or design professional responsible for preparing certification. All certificates and certifications must be signed by an authorized officer or other individual authorized to sign documents on behalf of the company.
 3. Test and Inspection Reports: Comply with requirements in Division 1 Section "Quality Requirements."
- B. Contractor's Construction Schedule: Comply with requirements in Division 1 Section "Construction Progress Documentation."
- C. Qualification Data: Prepare written information that demonstrates capabilities and experience of firm or person. Include lists of completed projects with project names and addresses, names and addresses of architects and owners, and other information specified.
- D. Product Certificates: Prepare written statements on manufacturer's letterhead certifying that product complies with requirements.
- E. Welding Certificates: Prepare written certification that welding procedures and personnel comply with requirements. Submit record of Welding Procedure Specification (WPS) and Procedure Qualification Record (PQR) on AWS forms. Include names of firms and personnel certified.
- F. Installer Certificates: Prepare written statements on manufacturer's letterhead certifying that Installer complies with requirements and, where required, is authorized for this specific Project.

- G. **Manufacturer Certificates:** Prepare written statements on manufacturer's letterhead certifying that manufacturer complies with requirements. Include evidence of manufacturing experience where required.
- H. **Material Certificates:** Prepare written statements on manufacturer's letterhead certifying that material complies with requirements.
- I. **Material Test Reports:** Prepare reports written by a qualified testing agency, on testing agency's standard form, indicating and interpreting test results of material for compliance with requirements.
- J. **Pre-construction Test Reports:** Prepare reports written by a qualified testing agency, on testing agency's standard form, indicating and interpreting results of tests performed before installation of product, for compliance with performance requirements.
- K. **Field Test Reports:** Prepare reports written by a qualified testing agency, on testing agency's standard form, indicating and interpreting results of field tests performed either during installation of product or after product is installed in its final location, for compliance with requirements.
- L. **Product Test Reports:** Prepare written reports indicating current product produced by manufacturer complies with requirements. Base reports on evaluation of tests performed by manufacturer and witnessed by a qualified testing agency, or on comprehensive tests performed by a qualified testing agency.
- M. **Research/Evaluation Reports:** Prepare written evidence, from a model code organization acceptable to authorities having jurisdiction, that product complies with building code in effect for Project. Include the following information:
 - 1. Name of evaluation organization.
 - 2. Date of evaluation.
 - 3. Time period when report is in effect.
 - 4. Product and manufacturers' names.
 - 5. Description of product.
 - 6. Test procedures and results.
 - 7. Limitations of use.
- N. **Maintenance Data:** Prepare written and graphic instructions and procedures for operation and normal maintenance of products and equipment. Comply with requirements in Division 1 Section "Closeout Procedures."
- O. **Design Data:** Prepare written and graphic information, including, but not limited to, performance and design criteria, list of applicable codes and regulations, and calculations. Include list of assumptions and other performance and design criteria and a summary of loads. Include load diagrams if applicable.
- P. **Manufacturer's Instructions:** Prepare written or published information that documents manufacturer's recommendations, guidelines, and procedures for installing or operating a product or equipment. Include name of product and name, address, and telephone number of manufacturer. Include the following, as applicable:
 - 1. Preparation of substrates.
 - 2. Required substrate tolerances.
 - 3. Sequence of installation or erection.
 - 4. Required installation tolerances.
 - 5. Required adjustments.

6. Recommendations for cleaning and protection.

- Q. Insurance Certificates and Bonds: Prepare written information indicating current status of insurance or bonding coverage. Include name of entity covered by insurance or bond, limits of coverage, amounts of deductibles, if any, and term of the coverage.
- R. Material Safety Data Sheets: Submit information directly to Owner. If submitted to Architect, Architect will not review this information but will return it with no action taken.

PART 3 - EXECUTION

3.1 CONTRACTOR'S REVIEW

- A. Review each submittal and check for coordination with other Work of the Contract and for compliance with the Contract Documents. Note corrections and field dimensions. Mark with approval stamp before submitting to Architect.

3.2 ARCHITECT'S ACTION

- A. General: Architect will not review submittals that do not bear Contractor's approval.
- B. Action Submittals: Architect will review each submittal, make marks to indicate corrections or modifications required, and return it. Architect will stamp each submittal with an action stamp or provide Architect's Standard Letter of Review, and will mark appropriately to indicate action taken.

END OF SECTION 013330

SECTION 014200 - REFERENCES

PART 1 - GENERAL

1.1 RELATED DOCUMENTS

- A. Drawings and general provisions of the Contract, including General and Supplementary Conditions and other Division 1 Specification Sections, apply to this Section.

1.2 DEFINITIONS

- A. General: Basic Contract definitions are included in the Conditions of the Contract.
- B. "Approved": The term "approved," when used in conjunction with Architect's action on Contractor's submittals, applications, and requests, is limited to Architect's duties and responsibilities as they are stated in the Conditions of the Contract.
- C. "Directed": Terms such as "directed," "requested," "authorized," "selected," "approved," "required," and "permitted" mean directed by Architect, requested by Architect, and similar phrases.
- D. "Indicated": The term "indicated" refers to graphic representations, notes, or schedules on Drawings; or to other paragraphs or schedules in Specifications and similar requirements in the Contract Documents. Terms such as "shown," "noted," "scheduled," and "specified" are used to help the user locate the reference.
- E. "Regulations": The term "regulations" includes laws, ordinances, statutes, and lawful orders issued by authorities having jurisdiction, as well as rules, conventions, and agreements within the construction industry that control performance of the Work.
- F. "Furnish": The term "furnish" means to supply and deliver to Project site, ready for unloading, unpacking, assembly, installation, and similar operations.
- G. "Install": The term "install" describes operations at Project site including unloading, temporary storage, unpacking, assembling, erecting, placing, anchoring, applying, working to dimension, finishing, curing, protecting, cleaning, and similar operations.
- H. "Provide": The term, "provide" means to furnish and install, and to complete and ready, for the intended use.
- I. "Installer": An installer is Contractor or another entity engaged by Contractor, as an employee, subcontractor, or contractor of lower tier, to perform a particular construction operation, including installation, erection, application, and similar operations.
- J. The term "experienced," when used with the term "installer," means having successfully completed a minimum of **five** previous projects similar in size and scope to this Project; being familiar with the special requirements indicated; and having complied with requirements of authorities having jurisdiction.
 - 1. Using a term such as "carpentry" does not imply that there are certain construction activities that must be performed by accredited or unionized individuals of a corresponding ge-

neric name, such as "carpenter." It also does not imply that requirements specified apply exclusively to tradesmen of the corresponding generic name.

- K. "Project site" is the space available for performing construction activities, either exclusively or in conjunction with others performing other work as part of Project. The extent of Project site is shown on the Drawings and may or may not be identical with the description of the land on which Project is to be built.

1.3 INDUSTRY STANDARDS

- A. **Applicability of Standards:** Unless the Contract Documents include more stringent requirements, applicable construction industry standards have the same force and effect as if bound or copied directly into the Contract Documents to the extent referenced. Such standards are made a part of the Contract Documents by reference.
- B. **Publication Dates:** Comply with standards in effect as of the date of the Contract Documents, unless otherwise indicated.
- C. **Conflicting Requirements:** Where compliance with two or more standards is specified and the standards establish different or conflicting requirements for minimum quantities or quality levels, comply with the most stringent requirement. Refer uncertainties and requirements that are different, but apparently equal, to Architect for a decision before proceeding.
 - 1. **Minimum Quantity or Quality Levels:** The quantity or quality level shown or specified shall be the minimum provided or performed. The actual installation may comply exactly with the minimum quantity or quality specified, or it may exceed the minimum within reasonable limits. To comply with these requirements, indicated numeric values are minimum or maximum, as appropriate, for the context of the requirements. Refer uncertainties to Architect for a decision before proceeding.
- D. **Copies of Standards:** Each entity engaged in construction on Project must be familiar with industry standards applicable to its construction activity. Copies of applicable standards are not bound with the Contract Documents.
 - 1. Where copies of standards are needed to perform a required construction activity, obtain copies directly from the publication source and make them available on request.
- E. **Abbreviations and Names:** Abbreviations and acronyms are frequently used in the Specifications and other Contract Documents to represent the name of a trade association, standards-developing organization, authorities having jurisdiction, or other entity in the context of referencing a standard or publication. Where abbreviations and acronyms are used in the Specifications or other Contract Documents, they mean the recognized name of these entities. Refer to Gale Research's "Encyclopedia of Associations" or Columbia Books' "National Trade & Professional Associations of the U.S.," which are available in most libraries.

PART 2 – PRODUCTS (Not used)

PART 3 - EXECUTION (Not Used)

END OF SECTION 014200

SECTION 015000 - TEMPORARY FACILITIES AND CONTROLS**PART 1 - GENERAL****1.1 RELATED DOCUMENTS**

- A. Drawings and general provisions of the Contract, including General and Supplementary Conditions and other Division 1 Specification Sections, apply to this Section.

1.2 SUMMARY

- A. This Section includes requirements for temporary utilities, support facilities, and security and protection facilities.

1.3 USE CHARGES

- A. General: Cost or use charges for temporary facilities shall not be included in the Contract Sum. Allow other entities to use temporary services and facilities without cost.
- B. Water Service: The owner shall pay water service use charges for water used by all entities for construction operations.
- C. Electric Power Service: The owner shall pay electric power service use charges for electricity used by all entities for construction operations.

1.4 QUALITY ASSURANCE

- A. Electric Service: Comply with NECA, NEMA, and UL standards and regulations for temporary electric service. Install service to comply with NFPA 70.

PART 2 - PRODUCTS**2.1 MATERIALS****2.2 TEMPORARY FACILITIES**

- A. Field Offices, General: Prefabricated or mobile units with serviceable finishes, temperature controls, and foundations adequate for normal loading.
- B. Common-Use Field Office: Of sufficient size to accommodate needs of construction personnel. Keep office clean and orderly. Furnish and equip offices as follows:
 - 1. Furniture required for Project-site documents including file cabinets, plan tables, plan racks, and bookcases.
 - 2. Heating and cooling equipment necessary to maintain a uniform indoor temperature of 68 to 72 deg F.
 - 3. Lighting fixtures capable of maintaining average illumination of 20 fc at desk height.

2.3 EQUIPMENT

- A. Fire Extinguishers: Portable, UL rated; with class and extinguishing agent as required by locations and classes of fire exposures.

- B. Heating Equipment: Unless Owner authorizes use of permanent heating system, provide vented, self-contained, liquid-propane-gas or fuel-oil heaters with individual space thermostatic control.

PART 3 - EXECUTION

3.1 INSTALLATION, GENERAL

- A. Locate facilities where they will serve Project adequately and result in minimum interference with performance of the Work. Relocate and modify facilities as required by progress of the Work.
- B. Provide each facility ready for use when needed to avoid delay. Do not remove until facilities are no longer needed or are replaced by authorized use of completed permanent facilities.

3.2 TEMPORARY UTILITY INSTALLATION

- A. General: Install temporary service or connect to existing service.
 - 1. Arrange with utility company, Owner, and existing users for time when service can be interrupted, if necessary, to make connections for temporary services.
- B. Water Service: Install water service and distribution piping in sizes and pressures adequate for construction.
- C. Sanitary Facilities: Provide temporary toilets, wash facilities, and drinking water for use of construction personnel. Comply with authorities having jurisdiction for type, number, location, operation, and maintenance of fixtures and facilities.
- D. Heating: Provide temporary heating required by construction activities for curing or drying of completed installations or for protecting installed construction from adverse effects of low temperatures or high humidity. Select equipment that will not have a harmful effect on completed installations or elements being installed.
- E. Electric Power Service: Provide electric power service and distribution system of sufficient size, capacity, and power characteristics required for construction operations.
- F. Lighting: Provide temporary lighting with local switching that provides adequate illumination for construction operations, observations, inspections, and traffic conditions.
- G. Telephone Service: Provide temporary telephone service in common-use facilities for use by all construction personnel. Install one telephone line(s) for each field office.
- H. Traffic Controls: Comply with requirements of authorities having jurisdiction.
 - 1. Protect existing site improvements to remain including curbs, pavement, and utilities.
 - 2. Maintain access for fire-fighting equipment and access to fire hydrants.
- I. Parking: Provide temporary parking areas for construction personnel.
- J. Dewatering Facilities and Drains: Comply with requirements of authorities having jurisdiction. Maintain Project site, excavations, and construction free of water.
 - 1. Dispose of rainwater in a lawful manner that will not result in flooding Project or adjoining properties nor endanger permanent Work or temporary facilities.
 - 2. Remove snow and ice as required to minimize accumulations.

- K. Project Identification and Temporary Signs: Provide Project identification sign. Install signs where indicated to inform public and individuals seeking entrance to Project. Unauthorized signs are not permitted.
- L. Waste Disposal Facilities: Provide waste-collection containers in sizes adequate to handle waste from construction operations. Comply with requirements of authorities having jurisdiction. Comply with Division 1 Section "Execution Requirements" for progress cleaning requirements.
- M. Temporary Stairs: Until permanent stairs are available, provide temporary stairs where ladders are not adequate.

3.3 SECURITY AND PROTECTION FACILITIES INSTALLATION

- A. Environmental Protection: Provide protection, operate temporary facilities, and conduct construction in ways and by methods that comply with environmental regulations and that minimize possible air, waterway, and subsoil contamination or pollution or other undesirable effects.
- B. Barricades, Warning Signs, and Lights: Comply with requirements of authorities having jurisdiction for erecting structurally adequate barricades, including warning signs and lighting.
- C. Temporary Fire Protection: Install and maintain temporary fire-protection facilities of types needed to protect against reasonably predictable and controllable fire losses. Comply with NFPA 241.
 - 1. Supervise welding operations, combustion-type temporary heating units, and similar sources of fire ignition according to requirements of authorities having jurisdiction.
 - 2. Develop and supervise an overall fire-prevention and -protection program for personnel at Project site. Review needs with local fire department and establish procedures to be followed. Instruct personnel in methods and procedures. Post warnings and information.

3.4 OPERATION, TERMINATION, AND REMOVAL

- A. Maintenance: Maintain facilities in good operating condition until removal.
 - 1. Maintain operation of temporary enclosures, heating, cooling, humidity control, ventilation, and similar facilities on a 24-hour basis where required to achieve indicated results and to avoid possibility of damage.
- B. Termination and Removal: Remove each temporary facility when need for its service has ended, when it has been replaced by authorized use of a permanent facility, or no later than Substantial Completion. Complete or, if necessary, restore permanent construction that may have been delayed because of interference with temporary facility. Repair damaged Work, clean exposed surfaces, and replace construction that cannot be satisfactorily repaired.

END OF SECTION 015000

SECTION 017310 - CUTTING AND PATCHING

PART 1 - GENERAL

1.1 RELATED DOCUMENTS

- A. Drawings and general provisions of the Contract, including General and Supplementary Conditions and other Division 1 Specification Sections, apply to this Section.

1.2 SUMMARY

- A. This Section includes procedural requirements for cutting and patching.
- B. Related Sections include the following:
 - 1. Divisions 2 through 33 Sections for specific requirements and limitations applicable to the cutting and patching of the individual parts of the Work.
 - a. Requirements in this Section also apply to mechanical and electrical installations.

1.3 DEFINITIONS

- A. Cutting: Removal of existing construction necessary to permit installation or performance of other Work.
- B. Patching: Fitting and repair work required to restore surfaces to original conditions after installation of other Work.

1.4 SUBMITTALS

- A. Cutting and Patching Proposal: Submit a proposal describing procedures at least 5 days before the time cutting and patching will be performed, requesting approval to proceed. Include the following information:
 - 1. Extent: Describe cutting and patching, show how they will be performed, and indicate why they cannot be avoided.
 - 2. Changes to Existing Construction: Describe anticipated results. Include changes to structural elements and operating components as well as changes in building's appearance and other significant visual elements.
 - 3. Products: List products to be used and firms or entities that will perform the Work.
 - 4. Dates: Indicate when cutting and patching will be performed.
 - 5. Utilities: List utilities that cutting and patching procedures will disturb or affect. List utilities that will be relocated and those that will be temporarily out of service. Indicate how long service will be disrupted. Coordinate with Owner's requirements to avoid shut-down of any portion of the facility
 - 6. Architect's Approval: Obtain approval of cutting and patching proposal before cutting and patching. Approval does not waive right to later require removal and replacement of unsatisfactory work.

1.5 QUALITY ASSURANCE

- A. Structural Elements: Do not cut and patch structural elements in a manner that could change their load-carrying capacity or load-deflection ratio. (If any question arises, consult the Architect).
- B. Operational Elements: Do not cut and patch operating elements and related components in a manner that results in reducing their capacity to perform as intended or that results in increased maintenance or decreased operational life or safety.
- C. Miscellaneous Elements: Do not cut and patch the following elements or related components in a manner that could change their load-carrying capacity, that results in reducing their capacity to perform as intended, or that results in increased maintenance or decreased operational life or safety.
 - 1. Water, moisture, or vapor barriers.
 - 2. Membranes and flashings.
 - 3. Equipment supports.
 - 4. Piping, ductwork, vessels, and equipment.
 - 5. Noise- and vibration-control elements and systems.
- D. Visual Requirements: Do not cut and patch construction in a manner that results in visual evidence of cutting and patching. Do not cut and patch construction exposed on the exterior or in occupied spaces in a manner that would, in Architect's opinion, reduce the building's aesthetic qualities. Remove and replace construction that has been cut and patched in a visually unsatisfactory manner.
- E. Cutting and Patching Conference: Before proceeding, meet at Project site with parties involved in cutting and patching, including mechanical and electrical trades. Review areas of potential interference and conflict. Coordinate procedures and resolve potential conflicts before proceeding.

1.6 WARRANTY

- A. Existing Warranties: Remove, replace, patch, and repair materials and surfaces cut or damaged during cutting and patching operations, by methods and with materials so as not to void existing warranties. (Existing warranties may require the cutting and patching to be performed by the original installing company).

PART 2 - PRODUCTS

2.1 MATERIALS

- A. General: Comply with requirements specified in other Sections of these Specifications.
- B. Existing Materials: Use materials identical to existing materials. For exposed surfaces, use materials that visually match existing adjacent surfaces to the fullest extent possible.
 - 1. If identical materials are unavailable or cannot be used, use materials that, when installed, will match the visual and functional performance of existing materials.

PART 3 - EXECUTION

3.1 EXAMINATION

- A. Examine surfaces to be cut and patched and conditions under which cutting and patching are to be performed.
 - 1. **Compatibility:** Before patching, verify compatibility with and suitability of substrates, including compatibility with existing finishes or primers.
 - 2. Proceed with installation only after unsafe or unsatisfactory conditions have been corrected.

3.2 PREPARATION

- A. **Temporary Support:** Provide temporary support of Work to be cut where required.
- B. **Protection:** Protect existing construction during cutting and patching to prevent damage. Provide protection from adverse weather conditions for portions of Project that might be exposed during cutting and patching operations.
- C. **Adjoining Areas:** Avoid interference with use of adjoining areas or interruption of free passage to adjoining areas.
- D. **Existing Services:** Where existing services are required to be removed, relocated, or abandoned, bypass such services before cutting to avoid interruption of services to occupied areas.

3.3 PERFORMANCE

- A. **General:** Employ skilled workers to perform cutting and patching. Proceed with cutting and patching at the earliest feasible time, and complete without delay.
 - 1. Cut existing construction to provide for installation of other components or performance of other construction, and subsequently patch as required to restore surfaces to their original condition.
- B. **Cutting:** Cut existing construction by sawing, drilling, breaking, chipping, grinding, and similar operations, including excavation, using methods least likely to damage elements retained or adjoining construction. If possible, review proposed procedures with original Installer; comply with original Installer's written recommendations.
 - 1. In general, use hand or small power tools designed for sawing and grinding, not hammering and chopping. Cut holes and slots as small as possible, neatly to size required, and with minimum disturbance of adjacent surfaces. Temporarily cover openings when not in use.
 - 2. **Existing Finished Surfaces:** Cut or drill from the exposed or finished side into concealed surfaces.
 - 3. **Concrete Paving:** Cut using a cutting machine, such as an abrasive saw or a diamond-core drill.
 - 4. **Excavating and Backfilling:** Comply with requirements in applicable Division 2 Sections where required by cutting and patching operations.

5. Mechanical and Electrical Services: Cut off pipe or conduit in walls or partitions to be removed. Cap, valve, or plug and seal remaining portion of pipe or conduit to prevent entrance of moisture or other foreign matter after cutting.
 6. Proceed with patching after construction operations requiring cutting are complete.
- C. Patching: Patch construction by filling, repairing, refinishing, closing up, and similar operations following performance of other Work. Patch with durable seams that are as invisible as possible. Provide materials and comply with installation requirements specified in other Sections of these Specifications.
1. Inspection: Where feasible, test and inspect patched areas after completion to demonstrate integrity of installation.
 2. Exposed Finishes: Restore exposed finishes of patched areas and extend finish restoration into retained adjoining construction in a manner that will eliminate evidence of patching and refinishing.
 3. Exterior Building Enclosure: Patch components in a manner that restores enclosure to a weather tight condition.
 4. Exterior building grounds: Repair all landscaped areas, site materials, and underground utilities damaged during construction.

END OF SECTION 017310

SECTION 017700 - CLOSEOUT PROCEDURES**PART 1 - GENERAL****1.1 RELATED DOCUMENTS**

- A. Drawings and general provisions of the Contract, including General and Supplementary Conditions and other Division 1 Specification Sections, apply to this Section.

1.2 SUMMARY

- A. This Section includes administrative and procedural requirements for contract closeout, including, but not limited to, the following:
 - 1. Inspection procedures.
 - 2. Record Documents
 - 3. Operation and Maintenance Manuals
 - 4. Warranties.
 - 5. Final cleaning.

1.3 SUBSTANTIAL COMPLETION

- A. Preliminary Procedures: Before requesting inspection for determining date of Substantial Completion, complete the following. List items below that are incomplete in request.
 - 1. Prepare a list of items to be completed and corrected (punch list), the value of items on the list, and reasons why the Work is not complete.
 - 2. Submit specific warranties, workmanship bonds, maintenance service agreements, final certifications, and similar documents.
 - 3. Prepare and submit Project Record Documents, operation and maintenance manuals and similar final record information.
 - 4. Deliver tools, spare parts, extra materials, and similar items to location designated by Owner. Label with manufacturer's name and model number where applicable.
 - 5. Complete startup testing of systems.
 - 6. Submit test/adjust/balance records.
 - 7. Terminate and remove temporary facilities from Project site, along with mockups, construction tools, and similar elements.
 - 8. Complete final cleaning requirements, including touchup painting.
- B. Inspection: Submit a written request for inspection for Substantial Completion. On receipt of request, Architect will proceed with inspection. Architect will prepare the Certificate of Substantial Completion after inspection or will notify Contractor of items, either on Contractor's list or additional items identified by Architect that must be completed or corrected before certificate will be issued.
 - 1. Reinspection: Request reinspection when the Work identified in previous inspections as incomplete is completed or corrected.
 - 2. Results of completed inspection will form the basis of requirements for Final Completion.

1.4 FINAL COMPLETION

- A. Preliminary Procedures: Before requesting final inspection for determining date of Final Completion, complete the following:

1. Submit a final Application for Payment according to Division 1 Section "Payment Procedures."
2. Submit certified copy of Architect's Substantial Completion inspection list of items to be completed or corrected (punch list), endorsed and dated by Architect. The certified copy of the list shall state that each item has been completed or otherwise resolved for acceptance.
3. Instruct Owner's personnel in operation, adjustment, and maintenance of products, equipment, and systems.

PART 2 - PRODUCTS

2.1 MATERIALS

- A. Cleaning Agents: Use cleaning materials and agents recommended by manufacturer or fabricator of the surface to be cleaned. Do not use cleaning agents that are potentially hazardous to health or property or that might damage finished surfaces.

PART 3 - EXECUTION

3.1 FINAL CLEANING

- A. General: Provide final cleaning. Conduct cleaning and waste-removal operations to comply with local laws and ordinances and Federal and local environmental and antipollution regulations.
- B. Cleaning: Employ experienced workers or professional cleaners for final cleaning. Clean each surface or unit to condition expected in an average commercial building cleaning and maintenance program. Comply with manufacturers written instructions.
 1. Complete the following cleaning operations before requesting inspection for certification of Substantial Completion for entire Project or for a portion of Project:
 - a. Clean Project site, yard, and grounds, in areas disturbed by construction activities, including landscape development areas, of rubbish, waste material, litter, and other foreign substances.
 - b. Sweep paved areas broom clean. Remove petrochemical spills, stains, and other foreign deposits.
 - c. Rake grounds that are neither planted nor paved to a smooth, even-textured surface.
 - d. Remove tools, construction equipment, machinery, and surplus material from Project site.
 - e. Clean exposed exterior and interior hard-surfaced finishes to a dirt-free condition, free of stains, films, and similar foreign substances. Avoid disturbing natural weathering of exterior surfaces. Restore reflective surfaces to their original condition.
 - f. Remove debris and surface dust from limited access spaces, including roofs, plenums, shafts, trenches, equipment vaults, manholes, attics, and similar spaces.
 - g. Sweep concrete floors broom clean in unoccupied spaces.
 - h. Vacuum carpet and similar soft surfaces, removing debris and excess nap; shampoo if visible soil or stains remain.
 - i. Clean transparent materials, including mirrors and glass in doors and windows. Remove glazing compounds and other noticeable, vision-obscuring materials. Replace chipped or broken glass and other damaged transparent materials. Polish mirrors and glass, taking care not to scratch surfaces.

- j. Remove labels that are not permanent.
 - k. Touch up and otherwise repair and restore marred, exposed finishes and surfaces. Replace finishes and surfaces that cannot be satisfactorily repaired or restored or that already show evidence of repair or restoration.
 - 1) Do not paint over "UL" and similar labels, including mechanical and electrical nameplates.
 - l. Wipe surfaces of mechanical and electrical equipment, elevator equipment, and similar equipment. Remove excess lubrication, paint and mortar droppings, and other foreign substances.
 - m. Clean plumbing fixtures to a sanitary condition, free of stains, including stains resulting from water exposure.
 - n. Clean exposed surfaces of diffusers, registers, and grills.
 - o. Clean light fixtures, lamps, globes, and reflectors to function with full efficiency. Replace burned-out bulbs, and those noticeably dimmed by hours of use, and defective and noisy starters in fluorescent and mercury vapor fixtures to comply with requirements for new fixtures.
 - p. Leave Project clean and ready for occupancy.
- C. Comply with safety standards for cleaning. Do not burn waste materials. Do not bury debris or excess materials on Owner's property. Do not discharge volatile, harmful, or dangerous materials into drainage systems. Remove waste materials from Project site and dispose of lawfully.

END OF SECTION 017700

SECTION 017823 - OPERATION AND MAINTENANCE DATA

1.1 SUMMARY

- A. Operation and Maintenance manuals.

1.2 PRODUCTS

- A. Format:

- 1. PDF electronic files with composite electronic index on digital media acceptable to Architect.
- 2. Heavy-duty, three-ring binders, two sets of copies.

- B. Operation Manuals: System, subsystem, and equipment descriptions, operating procedures, wiring diagrams, control diagrams and sequence of operation, and piped system diagrams.

- C. Product Maintenance Manuals: Source information, product information, maintenance procedures, repair materials and sources, and warranties and bonds.

- D. Systems and Equipment Maintenance Manuals: Source information, manufacturers' maintenance documentation, maintenance procedures, maintenance and service schedules, spare parts list and source information, maintenance service contracts, and warranties and bonds.

END OF SECTION 017823

SECTION 017839 - PROJECT RECORD DOCUMENTS

1.1 PRODUCTS

- A. Record Drawings: One set of marked-up record prints, or electronic copy at approval of architect.
- A. Record Specifications: One paper copy or electronic copy at approval of architect.
- B. Record Product Data: One paper copy or electronic copy at approval of architect.
- C. Miscellaneous Record Submittals: One paper copy or electronic copy at approval of architect.

1.2 PRODUCTS

- A. Record Prints: One set of paper copies of Contract Documents & Shop Drawings, marked to show actual installation.
- B. Electronic Copy: One .PDF file of Contract Documents & Shop Drawing, marked to show actual installation.

END OF SECTION 017839

SECTION 024119 - SELECTIVE DEMOLITION

PART 1 - GENERAL

1.1 RELATED DOCUMENTS

- A. Drawings and general provisions of the Contract, including General and Supplementary Conditions and Division 01 Specification Sections, apply to this Section.

1.2 SUMMARY

A. Section Includes:

1. Demolition and removal of selected portions of building or structure.
2. Demolition and removal of selected site elements.
3. Salvage of existing items to be reused or recycled.

B. Related Requirements:

1. Section 011000 "Summary" for restrictions on use of the premises, Owner-occupancy requirements, and phasing requirements.
2. Section 015639 "Temporary Tree and Plant Protection" for temporary protection of existing trees and plants that are affected by selective demolition.
3. Section 017300 "Execution" for cutting and patching procedures.
4. Section 013516 "Alteration Project Procedures" for general protection and work procedures for alteration projects.
5. Section 311000 "Site Clearing" for site clearing and removal of above- and below-grade improvements not part of selective demolition.

1.3 DEFINITIONS

- A. Remove: Detach items from existing construction and dispose of them off-site unless indicated to be salvaged or reinstalled.
- B. Remove and Salvage: Detach items from existing construction, in a manner to prevent damage, and deliver to Owner ready for reuse.
- C. Remove and Reinstall: Detach items from existing construction, in a manner to prevent damage, prepare for reuse, and reinstall where indicated.
- D. Existing to Remain: Leave existing items that are not to be removed and that are not otherwise indicated to be salvaged or reinstalled.
- E. Dismantle: To remove by disassembling or detaching an item from a surface, using gentle methods and equipment to prevent damage to the item and surfaces; disposing of items unless indicated to be salvaged or reinstalled.

1.4 MATERIALS OWNERSHIP

- A. Unless otherwise indicated, demolition waste becomes property of Contractor.
- B. Historic items, relics, antiques, and similar objects including, but not limited to, cornerstones and their contents, commemorative plaques and tablets, and other items of interest or value to Owner that may be uncovered during demolition remain the property of Owner.
 - 1. Carefully salvage in a manner to prevent damage and promptly return to Owner.

1.5 PREINSTALLATION MEETINGS

- A. Predemolition Conference: Conduct conference at Project site.
 - 1. Inspect and discuss condition of construction to be selectively demolished.
 - 2. Review structural load limitations of existing structure.
 - 3. Review and finalize selective demolition schedule and verify availability of materials, demolition personnel, equipment, and facilities needed to make progress and avoid delays.
 - 4. Review requirements of work performed by other trades that rely on substrates exposed by selective demolition operations.
 - 5. Review areas where existing construction is to remain and requires protection.

1.6 INFORMATIONAL SUBMITTALS

- A. Qualification Data: For refrigerant recovery technician.
- B. Engineering Survey: Submit engineering survey of condition of building.
- C. Proposed Protection Measures: Submit report, including Drawings, that indicates the measures proposed for protecting individuals and property for environmental protection, for dust control and, for noise control. Indicate proposed locations and construction of barriers.
- D. Schedule of Selective Demolition Activities: Indicate the following:
 - 1. Detailed sequence of selective demolition and removal work, with starting and ending dates for each activity. Ensure Owner's building manager's and other tenants' on-site operations are uninterrupted.
 - 2. Interruption of utility services. Indicate how long utility services will be interrupted.
 - 3. Coordination for shutoff, capping, and continuation of utility services.
 - 4. Use of elevator and stairs.
 - 5. Coordination of Owner's continuing occupancy of portions of existing building and of Owner's partial occupancy of completed Work.
- E. Predemolition Photographs or Video: Show existing conditions of adjoining construction, including finish surfaces, that might be misconstrued as damage caused by demolition operations. Comply with Section 013233 "Photographic Documentation." Submit before Work begins.
- F. Statement of Refrigerant Recovery: Signed by refrigerant recovery technician responsible for recovering refrigerant, stating that all refrigerant that was present was recovered and that recovery was performed according to EPA regulations. Include name and address of technician and date refrigerant was recovered.

- G. Warranties: Documentation indicating that existing warranties are still in effect after completion of selective demolition.

1.7 CLOSEOUT SUBMITTALS

- A. Inventory: Submit a list of items that have been removed and salvaged.

1.8 QUALITY ASSURANCE

- A. Refrigerant Recovery Technician Qualifications: Certified by an EPA-approved certification program.

1.9 FIELD CONDITIONS

- A. Owner will occupy portions of building immediately adjacent to selective demolition area. Conduct selective demolition so Owner's operations will not be disrupted.
- B. Conditions existing at time of inspection for bidding purpose will be maintained by Owner as far as practical.
 - 1. Before selective demolition, Owner will remove the following items:
 - a. As indicated on drawings.
- C. Notify Architect of discrepancies between existing conditions and Drawings before proceeding with selective demolition.
- D. Hazardous Materials: It is not expected that hazardous materials will be encountered in the Work.
 - 1. Hazardous materials will be removed by Owner before start of the Work.
 - 2. If suspected hazardous materials are encountered, do not disturb; immediately notify Architect and Owner. Hazardous materials will be removed by Owner under a separate contract.
- E. Hazardous Materials: Present in buildings and structures to be selectively demolished. A report on the presence of hazardous materials is on file for review and use. Examine report to become aware of locations where hazardous materials are present.
 - 1. Hazardous material remediation is specified elsewhere in the Contract Documents.
 - 2. Do not disturb hazardous materials or items suspected of containing hazardous materials except under procedures specified elsewhere in the Contract Documents.
 - 3. Owner will provide material safety data sheets for suspected hazardous materials that are known to be present in buildings and structures to be selectively demolished because of building operations or processes performed there.
- F. Historic Areas: Demolition and hauling equipment and other materials shall be of sizes that clear surfaces within historic spaces, areas, rooms, and openings, including temporary protection, by **12 inches**.
- G. Storage or sale of removed items or materials on-site is not permitted.

- H. Utility Service: Maintain existing utilities indicated to remain in service and protect them against damage during selective demolition operations.
 - 1. Maintain fire-protection facilities in service during selective demolition operations.

1.10 WARRANTY

- A. Existing Warranties: Remove, replace, patch, and repair materials and surfaces cut or damaged during selective demolition, by methods and with materials and using approved contractors so as not to void existing warranties.
- B. Notify warrantor on completion of selective demolition, and obtain documentation verifying that existing system has been inspected and warranty remains in effect. Submit documentation at Project closeout.

1.11 COORDINATION

- A. Arrange selective demolition schedule so as not to interfere with Owner's operations.

PART 2 - PRODUCTS

2.1 PERFORMANCE REQUIREMENTS

- A. Regulatory Requirements: Comply with governing EPA notification regulations before beginning selective demolition. Comply with hauling and disposal regulations of authorities having jurisdiction.
- B. Standards: Comply with ASSE A10.6 and NFPA 241.

PART 3 - EXECUTION

3.1 EXAMINATION

- A. Verify that utilities have been disconnected and capped before starting selective demolition operations.
- B. Review Project Record Documents of existing construction or other existing condition and hazardous material information provided by Owner. Owner does not guarantee that existing conditions are same as those indicated in Project Record Documents.
- C. Perform an engineering survey of condition of building to determine whether removing any element might result in structural deficiency or unplanned collapse of any portion of structure or adjacent structures during selective building demolition operations.
 - 1. Perform surveys as the Work progresses to detect hazards resulting from selective demolition activities.
- D. Steel Tendons: Locate tensioned steel tendons and include recommendations for de-tensioning.

- E. Verify that hazardous materials have been remediated before proceeding with building demolition operations.
- F. Survey of Existing Conditions: Record existing conditions by use of preconstruction photographs or video.
 - 1. Comply with requirements specified in Section 013233 "Photographic Documentation."
 - 2. Inventory and record the condition of items to be removed and salvaged. Provide photographs or video of conditions that might be misconstrued as damage caused by salvage operations.
 - 3. Before selective demolition or removal of existing building elements that will be reproduced or duplicated in final Work, make permanent record of measurements, materials, and construction details required to make exact reproduction.

3.2 PREPARATION

- A. Refrigerant: Before starting demolition, remove refrigerant from mechanical equipment according to 40 CFR 82 and regulations of authorities having jurisdiction.

3.3 UTILITY SERVICES AND MECHANICAL/ELECTRICAL SYSTEMS

- A. Existing Services/Systems to Remain: Maintain services/systems indicated to remain and protect them against damage.
- B. Existing Services/Systems to Be Removed, Relocated, or Abandoned: Locate, identify, disconnect, and seal or cap off utility services and mechanical/electrical systems serving areas to be selectively demolished.
 - 1. Owner will arrange to shut off indicated services/systems when requested by Contractor.
 - 2. Arrange to shut off utilities with utility companies.
 - 3. If services/systems are required to be removed, relocated, or abandoned, provide temporary services/systems that bypass area of selective demolition and that maintain continuity of services/systems to other parts of building.
 - 4. Disconnect, demolish, and remove fire-suppression systems, plumbing, and HVAC systems, equipment, and components indicated on Drawings to be removed.
 - a. Piping to Be Removed: Remove portion of piping indicated to be removed and cap or plug remaining piping with same or compatible piping material.
 - b. Piping to Be Abandoned in Place: Drain piping and cap or plug piping with same or compatible piping material and leave in place.
 - c. Equipment to Be Removed: Disconnect and cap services and remove equipment.
 - d. Equipment to Be Removed and Reinstalled: Disconnect and cap services and remove, clean, and store equipment; when appropriate, reinstall, reconnect, and make equipment operational.
 - e. Equipment to Be Removed and Salvaged: Disconnect and cap services and remove equipment and deliver to Owner.
 - f. Ducts to Be Removed: Remove portion of ducts indicated to be removed and plug remaining ducts with same or compatible ductwork material.
 - g. Ducts to Be Abandoned in Place: Cap or plug ducts with same or compatible ductwork material and leave in place.

3.4 PROTECTION

- A. Temporary Protection: Provide temporary barricades and other protection required to prevent injury to people and damage to adjacent buildings and facilities to remain.
1. Provide protection to ensure safe passage of people around selective demolition area and to and from occupied portions of building.
 2. Provide temporary weather protection, during interval between selective demolition of existing construction on exterior surfaces and new construction, to prevent water leakage and damage to structure and interior areas.
 3. Protect walls, ceilings, floors, and other existing finish work that are to remain or that are exposed during selective demolition operations.
 4. Cover and protect furniture, furnishings, and equipment that have not been removed.
 5. Comply with requirements for temporary enclosures, dust control, heating, and cooling specified in Section 015000 "Temporary Facilities and Controls."
- B. Temporary Shoring: Design, provide, and maintain shoring, bracing, and structural supports as required to preserve stability and prevent movement, settlement, or collapse of construction and finishes to remain, and to prevent unexpected or uncontrolled movement or collapse of construction being demolished.
1. Strengthen or add new supports when required during progress of selective demolition.
- C. Remove temporary barricades and protections where hazards no longer exist.

3.5 SELECTIVE DEMOLITION, GENERAL

- A. General: Demolish and remove existing construction only to the extent required by new construction and as indicated. Use methods required to complete the Work within limitations of governing regulations and as follows:
1. Proceed with selective demolition systematically, from higher to lower level. Complete selective demolition operations above each floor or tier before disturbing supporting members on the next lower level.
 2. Neatly cut openings and holes plumb, square, and true to dimensions required. Use cutting methods least likely to damage construction to remain or adjoining construction. Use hand tools or small power tools designed for sawing or grinding, not hammering and chopping. Temporarily cover openings to remain.
 3. Cut or drill from the exposed or finished side into concealed surfaces to avoid marring existing finished surfaces.
 4. Do not use cutting torches until work area is cleared of flammable materials. At concealed spaces, such as duct and pipe interiors, verify condition and contents of hidden space before starting flame-cutting operations. Maintain portable fire-suppression devices during flame-cutting operations.
 5. Maintain fire watch during and for at least 24 hours after flame-cutting operations.
 6. Maintain adequate ventilation when using cutting torches.
 7. Remove decayed, vermin-infested, or otherwise dangerous or unsuitable materials and promptly dispose of off-site.
 8. Remove structural framing members and lower to ground by method suitable to avoid free fall and to prevent ground impact or dust generation.
 9. Locate selective demolition equipment and remove debris and materials so as not to impose excessive loads on supporting walls, floors, or framing.
 10. Dispose of demolished items and materials promptly.

- B. **Site Access and Temporary Controls:** Conduct selective demolition and debris-removal operations to ensure minimum interference with roads, streets, walks, walkways, and other adjacent occupied and used facilities.
- C. **Work in Historic Areas:** Selective demolition may be performed only in areas of Project that are not designated as historic. In historic spaces, areas, and rooms, or on historic surfaces, the terms "demolish" or "remove" shall mean historic "removal" or "dismantling" as specified in Section 024296 "Historic Removal and Dismantling."
- D. **Removed and Salvaged Items:**
 - 1. Clean salvaged items.
 - 2. Pack or crate items after cleaning. Identify contents of containers.
 - 3. Store items in a secure area until delivery to Owner.
 - 4. Transport items to Owner's storage area off-site designated by Owner and as indicated on Drawings.
 - 5. Protect items from damage during transport and storage.
- E. **Removed and Reinstalled Items:**
 - 1. Clean and repair items to functional condition adequate for intended reuse.
 - 2. Pack or crate items after cleaning and repairing. Identify contents of containers.
 - 3. Protect items from damage during transport and storage.
 - 4. Reinstall items in locations indicated. Comply with installation requirements for new materials and equipment. Provide connections, supports, and miscellaneous materials necessary to make item functional for use indicated.
- F. **Existing Items to Remain:** Protect construction indicated to remain against damage and soiling during selective demolition. When permitted by Architect, items may be removed to a suitable, protected storage location during selective demolition and cleaned and reinstalled in their original locations after selective demolition operations are complete.

3.6 SELECTIVE DEMOLITION PROCEDURES FOR SPECIFIC MATERIALS

- A. **Concrete:** Demolish in small sections. Using power-driven saw, cut concrete to a depth of at least **3/4 inch (19 mm)** at junctures with construction to remain. Dislodge concrete from reinforcement at perimeter of areas being demolished, cut reinforcement, and then remove remainder of concrete. Neatly trim openings to dimensions indicated.
- B. **Concrete:** Demolish in sections. Cut concrete full depth at junctures with construction to remain and at regular intervals using power-driven saw, and then remove concrete between saw cuts.
- C. **Masonry:** Demolish in small sections. Cut masonry at junctures with construction to remain, using power-driven saw, and then remove masonry between saw cuts.
- D. **Concrete Slabs-on-Grade:** Saw-cut perimeter of area to be demolished, and then break up and remove.
- E. **Resilient Floor Coverings:** Remove floor coverings and adhesive according to recommendations in RFCI's "Recommended Work Practices for the Removal of Resilient Floor Coverings. Do not use methods requiring solvent-based adhesive strippers.
- F. **Roofing:** Remove no more existing roofing than what can be covered in one day by new roofing and so that building interior remains watertight and weathertight.

1. Remove existing roof membrane, flashings, copings, and roof accessories.
2. Remove existing roofing system down to substrate.

3.7 DISPOSAL OF DEMOLISHED MATERIALS

- A. Remove demolition waste materials from Project site and dispose of them in an EPA-approved construction and demolition waste landfill acceptable to authorities having jurisdiction.
1. Do not allow demolished materials to accumulate on-site.
 2. Remove and transport debris in a manner that will prevent spillage on adjacent surfaces and areas.
 3. Remove debris from elevated portions of building by chute, hoist, or other device that will convey debris to grade level in a controlled descent.
 4. Comply with requirements specified in Section 017419 "Construction Waste Management and Disposal."
- B. Burning: Do not burn demolished materials.

3.8 CLEANING

- A. Clean adjacent structures and improvements of dust, dirt, and debris caused by selective demolition operations. Return adjacent areas to condition existing before selective demolition operations began.

3.9 SELECTIVE DEMOLITION SCHEDULE

- A. Remove: As indicated on drawings.
- B. Remove and Salvage: As indicated on drawings.
- C. Remove and Reinstall: As indicated on drawings.
- D. Existing to Remain: As indicated on drawings.
- E. Dismantle: As indicated on drawings.

END OF SECTION 024119

SECTION 05 1200 – STRUCTURAL STEEL FRAMING

PART 1 - GENERAL

1.1 SUMMARY

- A. Section includes structural steel and grout.
- B. Related Sections:
 - 1. Section 051213 "Architecturally Exposed Structural Steel Framing" for additional requirements for architecturally exposed structural steel.

1.2 DEFINITIONS

- A. Structural Steel: Elements of structural-steel frame, as classified by AISC 303, "Code of Standard Practice for Steel Buildings and Bridges."

1.3 PERFORMANCE REQUIREMENTS

- A. Connections: Provide details of simple shear connections required by the Contract Documents to be selected or completed by structural-steel fabricator to withstand loads indicated and comply with other information and restrictions indicated.
 - 1. Select and complete connections using schematic details indicated and AISC 360.
 - 2. Use ASD; data are given at service-load level.

1.4 ACTION SUBMITTALS

- A. Shop Drawings: Show fabrication of structural-steel components.

1.5 INFORMATIONAL SUBMITTALS

- A. Qualification Data: For qualified fabricator.
- B. Welding certificates.

1.6 QUALITY ASSURANCE

- A. Fabricator Qualifications: A qualified fabricator that participates in the AISC Quality Certification Program and is designated an AISC-Certified Plant, Category STD.
- B. Installer Qualifications: A qualified installer who participates in the AISC Quality Certification Program and is designated an AISC-Certified Erector, Category CSE.

- C. Welding Qualifications: Qualify procedures and personnel according to AWS D1.1/D1.1M, "Structural Welding Code - Steel."
- D. Comply with applicable provisions of the following specifications and documents:
 - 1. AISC 303.
 - 2. AISC 360.
 - 3. RCSC's "Specification for Structural Joints Using ASTM A 325 or A 490 Bolts."
- E. Preinstallation Conference: Conduct conference at Project site.

PART 2 - PRODUCTS

2.1 STRUCTURAL-STEEL MATERIALS

- A. Structural Shapes: As indicated.
- B. Welding Electrodes: Comply with AWS requirements.

2.2 BOLTS, CONNECTORS, AND ANCHORS

- A. High-Strength Bolts, Nuts, and Washers: ASTM A 325, Type 1, heavy-hex steel structural bolts; ASTM A 563, Grade C, heavy-hex carbon-steel nuts; heavy-hex carbon-steel nuts and ASTM F 436, Type 1, hardened carbon-steel washers; all with plain finish.
- B. Shear Connectors: ASTM A 108, Grades 1015 through 1020, headed-stud type, cold-finished carbon steel; AWS D1.1/D1.1M, Type B.
- C. Unheaded Anchor Rods: As indicated.
- D. Headed Anchor Rods: As indicated.
- E. Threaded Rods: As indicated.

2.3 PRIMER

- A. Low-Emitting Materials: Paints and coatings shall comply with the testing and product requirements of the California Department of Health Services' "Standard Practice for the Testing of Volatile Organic Emissions from Various Sources Using Small-Scale Environmental Chambers."
- B. Primer: Comply with Section 099113 "Exterior Painting" and Section 099123 "Interior Painting."
- C. Primer: SSPC-Paint 25, Type I, zinc oxide, alkyd, linseed oil primer.
- D. Primer: Fabricator's standard lead- and chromate-free, nonasphaltic, rust-inhibiting primer complying with MPI#79 and compatible with topcoat.

2.4 GROUT

- A. Nonmetallic, Shrinkage-Resistant Grout: ASTM C 1107, factory-packaged, nonmetallic aggregate grout, noncorrosive and nonstaining, mixed with water to consistency suitable for application and a 30-minute working time.

2.5 FABRICATION

- A. Structural Steel: Fabricate and assemble in shop to greatest extent possible. Fabricate according to AISC's "Code of Standard Practice for Steel Buildings and Bridges" and AISC 360.
- B. Shear Connectors: Prepare steel surfaces as recommended by manufacturer of shear connectors. Use automatic end welding of headed-stud shear connectors according to AWS D1.1/D1.1M and manufacturer's written instructions.

2.6 SHOP CONNECTIONS

- A. High-Strength Bolts: Shop install high-strength bolts according to RCSC's "Specification for Structural Joints Using ASTM A 325 or A 490 Bolts" for type of bolt and type of joint specified.
 - 1. Joint Type: Snug tightened.
- B. Weld Connections: Comply with AWS D1.1/D1.1M for tolerances, appearances, welding procedure specifications, weld quality, and methods used in correcting welding work.

2.7 SHOP PRIMING

- A. Shop prime steel surfaces except the following:
 - 1. Surfaces embedded in concrete or mortar. Extend priming of partially embedded members to a depth of 2 inches.
 - 2. Surfaces to be field welded.
 - 3. Surfaces to be high-strength bolted with slip-critical connections.
 - 4. Surfaces to receive sprayed fire-resistive materials (applied fireproofing).
 - 5. Galvanized surfaces.
- B. Surface Preparation: Clean surfaces to be painted. Remove loose rust and mill scale and spatter, slag, or flux deposits. Prepare surfaces according to the following specifications and standards:
 - 1. SSPC-SP 2, "Hand Tool Cleaning."
 - 2. SSPC-SP 3, "Power Tool Cleaning."
- C. Priming: Immediately after surface preparation, apply primer according to manufacturer's written instructions and at rate recommended by SSPC to provide a minimum dry film thickness of 1.5 mils. Use priming methods that result in full coverage of joints, corners, edges, and exposed surfaces.

2.8 SOURCE QUALITY CONTROL

- A. Testing Agency: Owner will engage an independent testing and inspecting agency to perform shop tests and inspections and prepare test reports.
 - 1. Provide testing agency with access to places where structural-steel work is being fabricated or produced to perform tests and inspections.
- B. Correct deficiencies in Work that test reports and inspections indicate does not comply with the Contract Documents.
- C. Bolted Connections: Shop-bolted connections will be inspected according to RCSC's "Specification for Structural Joints Using ASTM A 325 or A 490 Bolts."
- D. Welded Connections: In addition to visual inspection, shop-welded connections will be tested and inspected according to AWS D1.1/D1.1M and the following inspection procedures, at testing agency's option:
 - 1. Liquid Penetrant Inspection: ASTM E 165.
 - 2. Magnetic Particle Inspection: ASTM E 709; performed on root pass and on finished weld. Cracks or zones of incomplete fusion or penetration will not be accepted.
 - 3. Ultrasonic Inspection: ASTM E 164.
 - 4. Radiographic Inspection: ASTM E 94.

PART 3 - EXECUTION

3.1 EXAMINATION

- A. Verify, with steel Erector present, elevations of concrete- and masonry-bearing surfaces and locations of anchor rods, bearing plates, and other embedments for compliance with requirements.
- B. Proceed with installation only after unsatisfactory conditions have been corrected.

3.2 ERECTION

- A. Set structural steel accurately in locations and to elevations indicated and according to AISC 303 and AISC 360.
- B. Base Plates: Clean concrete- and masonry-bearing surfaces of bond-reducing materials, and roughen surfaces prior to setting plates. Clean bottom surface of plates.
 - 1. Set plates for structural members on wedges, shims, or setting nuts as required.
 - 2. Weld plate washers to top of baseplate.
 - 3. Snug-tighten anchor rods after supported members have been positioned and plumbed. Do not remove wedges or shims but, if protruding, cut off flush with edge of plate before packing with grout.
 - 4. Promptly pack grout solidly between bearing surfaces and plates so no voids remain. Neatly finish exposed surfaces; protect grout and allow to cure. Comply with manufacturer's written installation instructions for shrinkage-resistant grouts.

- C. Maintain erection tolerances of structural steel within AISC's "Code of Standard Practice for Steel Buildings and Bridges."

3.3 FIELD CONNECTIONS

- A. High-Strength Bolts: Install high-strength bolts according to RCSC's "Specification for Structural Joints Using ASTM A 325 or A 490 Bolts" for type of bolt and type of joint specified.
 - 1. Joint Type: Snug tightened.
- B. Weld Connections: Comply with AWS D1.1/D1.1M for tolerances, appearances, welding procedure specifications, weld quality, and methods used in correcting welding work.
 - 1. Comply with AISC 303 and AISC 360 for bearing, alignment, adequacy of temporary connections, and removal of paint on surfaces adjacent to field welds.

3.4 FIELD QUALITY CONTROL

- A. Testing Agency: Owner will engage a qualified independent testing and inspecting agency to inspect field welds and high-strength bolted connections.
- B. Bolted Connections: Bolted connections will be inspected according to RCSC's "Specification for Structural Joints Using ASTM A 325 or A 490 Bolts."
- C. Welded Connections: Field welds will be visually inspected according to AWS D1.1/D1.1M.
 - 1. In addition to visual inspection, field welds will be tested and inspected according to AWS D1.1/D1.1M and the following inspection procedures, at testing agency's option:
 - a. Liquid Penetrant Inspection: ASTM E 165.
 - b. Magnetic Particle Inspection: ASTM E 709; performed on root pass and on finished weld. Cracks or zones of incomplete fusion or penetration will not be accepted.
 - c. Ultrasonic Inspection: ASTM E 164.
 - d. Radiographic Inspection: ASTM E 94.
- D. Correct deficiencies in Work that test reports and inspections indicate does not comply with the Contract Documents.

END OF SECTION 05 1200

SECTION 055000 - METAL FABRICATIONS

PART 1 - GENERAL

1.1 RELATED DOCUMENTS

- A. Drawings and general provisions of the Contract, including General and Supplementary Conditions and Division 1 Specification Sections, apply to this Section.

1.2 SUMMARY

- A. This Section includes the following:
 - 1. Loose bearing and leveling angles.
 - 2. Loose steel lintels.
- B. Related Sections include the following:
 - 1. Division 5 Section "Structural Steel Framing."

1.3 SUBMITTALS

- A. Shop Drawings: Show fabrication and installation details for metal fabrications.
 - 1. Include plans, elevations, sections, and details of metal fabrications and their connections. Show anchorage and accessory items.
- B. Welding certificates.

1.4 QUALITY ASSURANCE

- A. Welding: Qualify procedures and personnel according to the following:
 - 1. AWS D1.1, "Structural Welding Code--Steel."

1.5 PROJECT CONDITIONS

- A. Field Measurements: Verify actual locations of walls and other construction contiguous with metal fabrications by field measurements before fabrication and indicate measurements on Shop Drawings.
 - 1. Established Dimensions: Where field measurements cannot be made without delaying the Work, establish dimensions and proceed with fabricating metal fabrications without field measurements. Coordinate wall and other contiguous construction to ensure that actual dimensions correspond to established dimensions.

1.6 COORDINATION

- A. Coordinate installation of anchorages for metal fabrications. Furnish setting drawings, templates, and directions for installing anchorages, including sleeves, concrete inserts, anchor bolts, and items with integral anchors, that are to be embedded in concrete or masonry. Deliver such items to Project site in time for installation.

PART 2 - PRODUCTS**2.1 METALS, GENERAL**

- A. Metal Surfaces, General: Provide materials with smooth, flat surfaces, unless otherwise indicated. For metal fabrications exposed to view in the completed Work, provide materials without seam marks, roller marks, rolled trade names, or blemishes.

2.2 FERROUS METALS

- A. Steel Plates, Shapes, and Bars: ASTM A 36/A 36M.
- B. Steel Pipe: ASTM A 53/A 53M, standard weight (Schedule 40), unless another weight is indicated or required by structural loads.

2.3 FASTENERS

- A. General: Unless otherwise indicated, provide Type zinc-plated fasteners with coating complying with ASTM B 633, Class Fe/Zn 5, at exterior walls. Select fasteners for type, grade, and class required.
- B. Steel Bolts and Nuts: Regular hexagon-head bolts, ASTM A 307, Grade A; with hex nuts, ASTM A 563; and, where indicated, flat washers.
- C. Anchor Bolts: ASTM F 1554, Grade 36.
- D. Machine Screws: ASME B18.6.3.
- E. Lag Bolts: ASME B18.2.1.
- F. Plain Washers: Round, ASME B18.22.1.
- G. Expansion Anchors: Anchor bolt and sleeve assembly with capability to sustain, without failure, a load equal to six times the load imposed when installed in unit masonry and four times the load imposed when installed in concrete, as determined by testing according to ASTM E 488, conducted by a qualified independent testing agency.

2.4 MISCELLANEOUS MATERIALS

- A. Welding Rods and Bare Electrodes: Select according to AWS specifications for metal alloy welded.
- B. Universal Shop Primer: Fast-curing, lead- and chromate-free, universal modified-alkyd primer complying with MPI#79.
- C. Galvanizing Repair Paint: High-zinc-dust-content paint for regalvanizing welds in steel, complying with SSPC-Paint 20.
- D. Bituminous Paint: Cold-applied asphalt emulsion complying with ASTM D 1187.

2.5 FABRICATION, GENERAL

- A. Shop Assembly: Preassemble items in the shop to greatest extent possible. Disassemble units only as necessary for shipping and handling limitations. Use connections that maintain structural value of joined pieces. Clearly mark units for reassembly and coordinated installation.

- B. Cut, drill, and punch metals cleanly and accurately. Remove burrs and ease edges to a radius of approximately 1/32 inch, unless otherwise indicated. Remove sharp or rough areas on exposed surfaces.
- C. Form bent-metal corners to smallest radius possible without causing grain separation or otherwise impairing work.
- D. Form exposed work true to line and level with accurate angles and surfaces and straight edges.
- E. Weld corners and seams continuously to comply with the following:
 - 1. Use materials and methods that minimize distortion and develop strength and corrosion resistance of base metals.
 - 2. Obtain fusion without undercut or overlap.
 - 3. Remove welding flux immediately.
 - 4. At exposed connections, finish exposed welds and surfaces smooth and blended so no roughness shows after finishing and contour of welded surface matches that of adjacent surface.
- F. Provide for anchorage of type indicated; coordinate with supporting structure. Space anchoring devices to secure metal fabrications rigidly in place and to support indicated loads.

2.6 MISCELLANEOUS FRAMING AND SUPPORTS

- A. General: Provide steel framing and supports not specified in other Sections as needed to complete the Work.
- B. Fabricate units from steel shapes, plates, and bars of welded construction, unless otherwise indicated. Fabricate to sizes, shapes, and profiles indicated and as necessary to receive adjacent construction retained by framing and supports. Cut, drill, and tap units to receive hardware, hangers, and similar items.

2.7 LOOSE STEEL LINTELS

- A. Fabricate loose steel lintels from steel angles and shapes of size indicated for openings and recesses in walls and partitions at locations indicated. Weld adjoining members together to form a single unit where indicated.
- B. Size loose lintels to provide bearing length at each side of openings equal to 1/12 of clear span but not less than 8 inches, unless otherwise indicated.
- C. Galvanize loose steel lintels located in exterior walls.

2.8 METAL LADDERS

- A. General:
 - 1. Comply with ANSI A14.3, unless otherwise indicated.
 - 2. Space siderails 18 inches apart, unless otherwise indicated.
 - 3. Support each ladder at top and bottom and not more than 60 inches with welded or bolted brackets, made from same metal as ladder.

2.9 UNISTRUT

- A. Provide unistrut as called for on the drawings for support of suspended equipment and display walls.

2.10 STEEL AND IRON FINISHES

- A. Shop Priming: Apply shop primer to uncoated surfaces of metal fabrications, except those with galvanized finishes and those to be embedded in concrete or masonry, unless otherwise indicated. Comply with SSPC-PA 1, "Paint Application Specification No. 1: Shop, Field, and Maintenance Painting of Steel," for shop painting.

2.11 GALVANIZING

- A. Hot-Dip Galvanized Finish: Apply zinc coating by the hot-dip process to structural steel according to ASTM A 123/ A 123M.
 - 1. Fill vent holes and grind smooth after galvanizing.
 - 2. Galvanize lintels and shelf angles attached to structural and located in exterior walls.

PART 3 - EXECUTION

3.1 INSTALLATION, GENERAL

- A. Cutting, Fitting, and Placement: Perform cutting, drilling, and fitting required for installing metal fabrications. Set metal fabrications accurately in location, alignment, and elevation; with edges and surfaces level, plumb, true, and free of rack; and measured from established lines and levels.
- B. Fit exposed connections accurately together to form hairline joints. Weld connections that are not to be left as exposed joints but cannot be shop welded because of shipping size limitations. Do not weld, cut, or abrade surfaces of exterior units that have been hot-dip galvanized after fabrication and are for bolted or screwed field connections.
- C. Field Welding: Comply with the following requirements:
 - 1. Use materials and methods that minimize distortion and develop strength and corrosion resistance of base metals.
 - 2. Obtain fusion without undercut or overlap.
 - 3. Remove welding flux immediately.
 - 4. At exposed connections, finish exposed welds and surfaces smooth and blended so no roughness shows after finishing and contour of welded surface matches that of adjacent surface.
- D. Fastening to In-Place Construction: Provide anchorage devices and fasteners where metal fabrications are required to be fastened to in-place construction. Provide threaded fasteners for use with concrete and masonry inserts, toggle bolts, through bolts, lag bolts, wood screws, and other connectors.

3.2 INSTALLING MISCELLANEOUS FRAMING AND SUPPORTS

- A. General: Install framing and supports to comply with requirements of items being supported, including manufacturers' written instructions and requirements indicated on Shop Drawings.

3.3 ADJUSTING AND CLEANING

- A. Touchup Painting: Immediately after erection, clean field welds, bolted connections, and abraded areas. Paint uncoated and abraded areas with the same material as used for shop painting to comply with SSPC-PA 1 for touching up shop-painted surfaces.
- B. Galvanized Surfaces: Clean field welds, bolted connections, and abraded areas and repair galvanizing to comply with ASTM A 780.

END OF SECTION 055000

SECTION 061053 - MISCELLANEOUS ROUGH CARPENTRY

PART 1 - GENERAL

1.1 RELATED DOCUMENTS

- A. Drawings and general provisions of the Contract, including General and Supplementary Conditions and Division 1 Specification Sections, apply to this Section.

1.2 SUMMARY

- A. This Section includes the following:
 - 1. Wood blocking and nailers.

1.3 DEFINITIONS

- A. Rough Carpentry: Carpentry work not specified in other Sections and not exposed, unless otherwise indicated.
- B. Lumber grading agencies, and the abbreviations used to reference them, include the following:
 - 1. WWPA - Western Wood Products Association.

1.4 SUBMITTALS

- A. Product Data: For each type of process and factory-fabricated product. Indicate component materials and dimensions and include construction and application details.
- B. Material Certificates: For dimension lumber specified to comply with minimum allowable unit stresses. Indicate species and grade selected for each use and design values approved by the American Lumber Standards Committee Board of Review.

1.5 QUALITY ASSURANCE

- A. Source Limitations for Engineered Wood Products: Obtain each type of engineered wood product through one source from a single manufacturer.

1.6 DELIVERY, STORAGE, AND HANDLING

- A. Stack lumber, plywood, and other panels; place spacers between each bundle to provide air circulation. Provide for air circulation around stacks and under coverings.
- B. Keep materials under cover and dry. Protect from weather and contact with damp or wet surfaces. Stack lumber, plywood, and other panels. Provide for air circulation within and around stacks and under temporary coverings.

PART 2 - PRODUCTS

2.1 MANUFACTURERS

- A. Manufacturers: Subject to compliance with requirements, provide products by one of the following:
1. Wood-Preservative-Treated Materials:
 - a. Baxter: J. H. Baxter Co.
 - b. Chemical Specialties, Inc.
 - c. Continental Wood Preservers, Inc.
 - d. Hickson Corp.
 - e. Hoover Treated Wood Products, Inc.
 - f. Osmose Wood Preserving, Inc.

2.2 WOOD PRODUCTS, GENERAL

- A. Lumber: DOC PS 20 and applicable rules of lumber grading agencies certified by the American Lumber Standards Committee Board of Review.
1. Factory mark each piece of lumber with grade stamp of grading agency.
 2. Provide dressed lumber, S4S, unless otherwise indicated.
 3. Provide dry lumber with 19 percent maximum moisture content at time of dressing for 2-inch nominal thickness or less, unless otherwise indicated.
- B. Wood Structural Panels:
1. Plywood: Either DOC PS 1 or DOC PS 2, unless otherwise indicated.
 2. Thickness: As needed to comply with requirements specified but not less than thickness indicated.
 3. Comply with "Code Plus" provisions in APA Form No. E30K, "APA Design/Construction Guide: Residential & Commercial."
 4. Factory mark panels according to indicated standard.

2.3 WOOD-PRESERVATIVE-TREATED MATERIALS

- A. General: Where wood-preservative-treated wood is indicated or required, comply with applicable requirements of AWPA C20 (lumber) and AWPA C27 (plywood). Identify wood-preservative-treated wood with appropriate classification markings; U.S. Testing; Timber Products Inspection, Inc.; or another testing and inspecting agency acceptable to authorities having jurisdiction.
- B. Exterior Type: Use for exterior locations and where indicated.

2.4 MISCELLANEOUS LUMBER

- A. General: Provide lumber for support or attachment of other construction, including the following:
1. Blocking.
 2. Nailers.
 3. Furring.
- B. For items of dimension lumber size, provide No. 2 grade lumber with 19 percent maximum moisture content of the following species:
1. Douglas fir-larch; WWPA.

2.5 FASTENERS

- A. General: Provide fasteners of size and type indicated that comply with requirements specified in this Article for material and manufacture.
- B. Nails, Brads, and Staples: ASTM F 1667.
- C. Wood Screws: ASME B18.6.1.
- D. Lag Bolts: ASME B18.2.1.
- E. Bolts: Steel bolts complying with ASTM A 307, Grade A; with ASTM A 563 hex nuts and, where indicated, flat washers.

PART 3 - EXECUTION

3.1 INSTALLATION, GENERAL

- A. Set rough carpentry to required levels and lines, with members plumb, true to line, cut, and fitted. Fit rough carpentry to other construction; scribe and cope as needed for accurate fit. Locate nailers, blocking, and similar supports to comply with requirements for attaching other construction.
- B. Do not use materials with defects that impair quality of rough carpentry or pieces that are too small to use with minimum number of joints or optimum joint arrangement.
- C. Securely attach rough carpentry work to substrate by anchoring and fastening as indicated, complying with the following:
 - 1. CABO NER-272 for power-driven fasteners.
 - 2. Published requirements of metal framing anchor manufacturer.
 - 3. Table 2304.9.1 in the International Building Code.
- D. Use common wire nails, unless otherwise indicated. Select fasteners of size that will not fully penetrate members where opposite side will be exposed to view or will receive finish materials. Make tight connections between members. Install fasteners without splitting wood; predrill as required.

3.2 WOOD BLOCKING AND NAILER INSTALLATION

- A. Install where indicated and where required for attaching other work. Form to shapes indicated and cut as required for true line and level of attached work. Coordinate locations with other work involved.
- B. Attach items to substrates to support applied loading. Recess bolts and nuts flush with surfaces, unless otherwise indicated.

3.3 WOOD STRUCTURAL PANEL INSTALLATION

- A. General: Comply with applicable recommendations contained in APA Form No. E30K, "APA Design/Construction Guide: Residential & Commercial," for types of structural-use panels and applications indicated.
 - 1. Comply with "Code Plus" provisions in above-referenced guide.

END OF SECTION 061053

SECTION 079200 - JOINT SEALANTS**PART 1 - GENERAL****1.1 RELATED DOCUMENTS**

- A. Drawings and general provisions of the Contract, including General and Supplementary Conditions and Division 1 Specification Sections, apply to this Section.

1.2 SUMMARY

- A. This Section includes sealants for the following applications, including those specified by reference to this Section:
 - 1. Exterior joints in the following surfaces and nontraffic horizontal surfaces:
 - a. Perimeter joints between dissimilar materials and frames of doors and windows.
 - b. Other joints as indicated.
 - 2. Exterior joints in the following horizontal traffic surfaces:
 - a. Control, expansion, and isolation joints in cast-in-place concrete slabs.
 - b. Other joints as indicated.
 - 3. Interior joints in the following vertical surfaces and horizontal nontraffic surfaces:
 - a. Vertical control joints on exposed surfaces of interior unit masonry and concrete walls and partitions.
 - b. Perimeter joints between interior wall surfaces and frames of interior doors, windows, and elevator entrances.
 - c. Joints between plumbing fixtures and adjoining walls, floors, and counters.
 - d. Other joints as indicated.

1.3 PERFORMANCE REQUIREMENTS

- A. Provide elastomeric joint sealants that establish and maintain watertight and airtight continuous joint seals without staining or deteriorating joint substrates.

1.4 SUBMITTALS

- A. Product Data: For each joint-sealant product indicated.

1.5 DELIVERY, STORAGE, AND HANDLING

- A. Deliver materials to Project site in original unopened containers or bundles with labels indicating manufacturer, product name and designation, color, expiration date, pot life, curing time, and mixing instructions for multicomponent materials.
- B. Store and handle materials in compliance with manufacturer's written instructions to prevent their deterioration or damage due to moisture, high or low temperatures, contaminants, or other causes.

1.6 PROJECT CONDITIONS

- A. Environmental Limitations: Do not proceed with installation of joint sealants under the following conditions:
 - 1. When ambient and substrate temperature conditions are outside limits permitted by joint sealant manufacturer.
- B. Joint-Width Conditions: Do not proceed with installation of joint sealants where joint widths are less than those allowed by joint sealant manufacturer for applications indicated.
- C. Joint-Substrate Conditions: Do not proceed with installation of joint sealants until contaminants capable of interfering with adhesion are removed from joint substrates.

PART 2 - PRODUCTS

2.1 PRODUCTS AND MANUFACTURERS

- A. Products: Subject to compliance with requirements, provide one of the products indicated for each type in the sealant schedules at the end of Part 3.

2.2 MATERIALS, GENERAL

- A. Compatibility: Provide joint sealants, backings, and other related materials that are compatible with one another and with joint substrates under conditions of service and application, as demonstrated by sealant manufacturer based on testing and field experience.
- B. Colors of Exposed Joint Sealants: As selected by Architect from manufacturer's full range for this characteristic.

2.3 ELASTOMERIC JOINT SEALANTS

- A. Elastomeric Sealant Standard: Comply with ASTM C 920 and other requirements indicated for each liquid-applied chemically curing sealant in the Elastomeric Joint-Sealant Schedule at the end of Part 3, including those referencing ASTM C 920 classifications for type, grade, class, and uses.

2.4 ACOUSTICAL JOINT SEALANTS

- A. Acoustical Sealant for Exposed and Concealed Joints: For each product of this description indicated in the Acoustical Joint-Sealant Schedule at the end of Part 3, provide manufacturer's standard nonsag, paintable, nonstaining latex sealant complying with ASTM C 834 and the following:
 - 1. Product effectively reduces airborne sound transmission through perimeter joints and openings in building construction as demonstrated by testing representative assemblies according to ASTM E 90.

2.5 JOINT-SEALANT BACKING

- A. General: Provide sealant backings of material and type that are nonstaining; are compatible with joint substrates, sealants, primers, and other joint fillers; and are approved for applications indicated by sealant manufacturer based on field experience and laboratory testing.

2.6 MISCELLANEOUS MATERIALS

- A. Primer: Material recommended by joint sealant manufacturer where required for adhesion of sealant to joint substrates indicated, as determined from preconstruction joint-sealant-substrate tests and field tests.
- B. Cleaners for Nonporous Surfaces: Chemical cleaners acceptable to manufacturers of sealants and sealant backing materials, free of oily residues or other substances capable of staining or harming joint substrates and adjacent nonporous surfaces in any way, and formulated to promote optimum adhesion of sealants with joint substrates.
- C. Masking Tape: Nonstaining, nonabsorbent material compatible with joint sealants and surfaces adjacent to joints.

PART 3 - EXECUTION

3.1 EXAMINATION

- A. Examine joints indicated to receive joint sealants, with Installer present, for compliance with requirements for joint configuration, installation tolerances, and other conditions affecting joint-sealant performance.
- B. Proceed with installation only after unsatisfactory conditions have been corrected.

3.2 PREPARATION

- A. Surface Cleaning of Joints: Clean out joints immediately before installing joint sealants to comply with joint sealant manufacturer's written instructions and the following requirements:
 - 1. Remove all foreign material from joint substrates that could interfere with adhesion of joint sealant, including dust, paints (except for permanent, protective coatings tested and approved for sealant adhesion and compatibility by sealant manufacturer), old joint sealants, oil, grease, waterproofing, water repellents, water, surface dirt, and frost.
 - 2. Clean porous joint substrate surfaces by brushing, grinding, blast cleaning, mechanical abrading, or a combination of these methods to produce a clean, sound substrate capable of developing optimum bond with joint sealants. Remove loose particles remaining from above cleaning operations by vacuuming or blowing out joints with oil-free compressed air. Porous joint surfaces include the following:
 - a. Concrete.
 - b. Masonry.
 - c. Unglazed surfaces of ceramic tile.
 - 3. Remove laitance and form-release agents from concrete.
- B. Joint Priming: Prime joint substrates where recommended in writing by joint sealant manufacturer, based on preconstruction joint-sealant-substrate tests or prior experience. Apply primer to comply with joint sealant manufacturer's written instructions. Confine primers to areas of joint-sealant bond; do not allow spillage or migration onto adjoining surfaces.
- C. Masking Tape: Use masking tape where required to prevent contact of sealant with adjoining surfaces that otherwise would be permanently stained or damaged by such contact or by cleaning methods required to remove sealant smears. Remove tape immediately after tooling without disturbing joint seal.

3.3 INSTALLATION OF JOINT SEALANTS

- A. General: Comply with joint sealant manufacturer's written installation instructions for products and applications indicated, unless more stringent requirements apply.
- B. Sealant Installation Standard: Comply with recommendations of ASTM C 1193 for use of joint sealants as applicable to materials, applications, and conditions indicated.
- C. Acoustical Sealant Application Standard: Comply with recommendations of ASTM C 919 for use of joint sealants in acoustical applications as applicable to materials, applications, and conditions indicated.
- D. Install sealant backings of type indicated to support sealants during application and at position required to produce cross-sectional shapes and depths of installed sealants relative to joint widths that allow optimum sealant movement capability.
- E. Install bond-breaker tape behind sealants where sealant backings are not used between sealants and back of joints.
- F. Install sealants by proven techniques to comply with the following and at the same time backings are installed:
 - 1. Place sealants so they directly contact and fully wet joint substrates.
 - 2. Completely fill recesses provided for each joint configuration.
 - 3. Produce uniform, cross-sectional shapes and depths relative to joint widths that allow optimum sealant movement capability.
- G. Tooling of Nonsag Sealants: Immediately after sealant application and before skinning or curing begins, tool sealants according to requirements specified below to form smooth, uniform beads of configuration indicated; to eliminate air pockets; and to ensure contact and adhesion of sealant with sides of joint.
 - 1. Remove excess sealants from surfaces adjacent to joint.
 - 2. Use tooling agents that are approved in writing by sealant manufacturer and that do not discolor sealants or adjacent surfaces.

3.4 CLEANING

- A. Clean off excess sealants or sealant smears adjacent to joints as the Work progresses by methods and with cleaning materials approved in writing by manufacturers of joint sealants and of products in which joints occur.

3.5 PROTECTION

- A. Protect joint sealants during and after curing period from contact with contaminating substances and from damage resulting from construction operations or other causes so sealants are without deterioration or damage at time of Substantial Completion. If, despite such protection, damage or deterioration occurs, cut out and remove damaged or deteriorated joint sealants immediately so installations with repaired areas are indistinguishable from the original work.

3.6 ELASTOMERIC JOINT-SEALANT SCHEDULE

- A. Multicomponent Nonsag Polysulfide Sealant: Where joint sealants of this type are indicated, provide products complying with the following:
 - 1. Products: Provide one of the following:
 - a. cm-60; W.R Meadows, Inc.
 - b. T-2235-M; Morton International, Inc.

- c. T-2282; Morton International, Inc.
- d. Thiokol 2P; Morton International, Inc.
- e. GC-5 Synthacalk; Pecora Corporation.
- f. Two-Part Sealant; Sonneborn Building Products Div., ChemRex Inc.
2. Type and Grade: M (multicomponent) and NS (nonsag).
3. Class: 25.
4. Uses Related to Exposure: T (traffic)

3.7 LATEX JOINT-SEALANT SCHEDULE

- A. Latex Sealant: Where joint sealants of this type are indicated, provide products complying with the following:
 1. Products: Provide one of the following:
 - a. Chem-Calk 600; Bostik Inc.
 - b. NuFlex 330; NUCO Industries, Inc.
 - c. LC 160 All Purpose Acrylic Caulk; Ohio Sealants, Inc.
 - d. AC-20; Pecora Corporation.
 - e. PSI-701; Polymeric Systems, Inc.
 - f. Sonolac; Sonneborn Building Products Div., ChemRex, Inc.
 - g. Tremflex 834; Tremco.

3.8 ACOUSTICAL JOINT-SEALANT SCHEDULE

- A. Acoustical Sealant for Exposed and Concealed Joints: At all sound partitions and where joint sealants of this type are indicated, provide products complying with the following:
 1. Products: Provide one of the following:
 - a. AC-20 FTR Acoustical and Insulation Sealant; Pecora Corporation.
 - b. SHEETROCK Acoustical Sealant; USG Corp., United States Gypsum Co.
- B. Acoustical Sealant for Concealed Joints: At all sound partitions and where joint sealants of this type are indicated, provide products complying with the following:
 1. Products: Provide one of the following:
 - a. Pro-Series SC-170 Rubber Base Sound Sealant; Ohio Sealants, Inc.
 - b. BA-98; Pecora Corporation.
 - c. Tremco Acoustical Sealant; Tremco.

END OF SECTION 079200

SECTION 08 1113 – HOLLOW METAL DOORS AND FRAMES

PART 1 - GENERAL

1.1 RELATED DOCUMENTS

- A. Drawings and general provisions of the Contract, including General and Supplementary Conditions and Division 1 Specification Sections, apply to this Section.

1.2 SUMMARY

- A. This Section includes the following:
 1. Interior hollow metal doors.
 2. Interior hollow metal door frames with hinge reinforcement
 3. Interior hollow metal window frames.
 4. Interior sidelight frames
 5. Fire-rated door and frame assemblies.
 6. Exterior hollow metal doors
 7. Exterior hollow metal door frames

1.3 DEFINITIONS

- A. Steel Sheet Thicknesses: Thickness dimensions, including those referenced in ANSI A250.8, are minimums as defined in referenced ASTM standards for both uncoated steel sheet and the uncoated base metal of metallic-coated steel sheets.

1.4 SUBMITTALS

- A. Product Data: For each type of door and frame indicated, include door designation, type, level and model, material description, core description, construction details, label compliance, sound and fire-resistance ratings, and finishes.
- B. Shop Drawings: Show the following:
 1. Elevations of each door design.
 2. Frame details for each frame type including dimensioned profiles.
 3. Details and locations of reinforcement and preparations for hardware.
 4. Details of each different wall opening condition.
 5. Details of anchorages, accessories, joints, and connections.
 6. Coordination of glazing frames and stops with glass and glazing requirements.
- C. Door Schedule: Use same reference designations indicated on Drawings in preparing schedule for doors and frames.

1.5 QUALITY ASSURANCE

- A. Steel Door and Frame Standard: Comply with ANSI A 250.8, unless more stringent requirements are indicated.
- B. Fire-Rated Door Assemblies: Assemblies complying with NFPA 80 that are listed and labeled by a testing and inspecting agency acceptable to authorities having jurisdiction, for fire-protection ratings indicated, based on testing according to NFPA 252.
- C. Fire-Rated Window Assemblies: Assemblies complying with NFPA 80 that are listed and labeled by a testing and inspecting agency acceptable to authorities having jurisdiction, for fire ratings indicated, based on testing according to NFPA 257.

1.6 DELIVERY, STORAGE, AND HANDLING

- A. Deliver doors and frames cardboard-wrapped or crated to provide protection during transit and job storage. Provide additional protection to prevent damage to finish of factory-finished doors and frames.
- B. Inspect doors and frames on delivery for damage, and notify shipper and supplier if damage is found. Minor damages may be repaired provided refinished items match new work and are acceptable to Architect. Remove and replace damaged items that cannot be repaired as directed.
- C. Store doors and frames at building site under cover. Place units on minimum 4-inch- high wood blocking. Avoid using nonvented plastic or canvas shelters that could create a humidity chamber. If door packaging becomes wet, remove cartons immediately. Provide minimum 1/4-inch spaces between stacked doors to permit air circulation.

PART 2 - PRODUCTS

2.1 MANUFACTURERS

- A. Manufacturers: Subject to compliance with requirements, provide products by one of the following:
 - 1. Steel Doors and Frames:
 - a. Amweld Building Products, Inc.
 - b. Benchmark Commercial Doors; a division of General Products Co., Inc.
 - c. Ceco Door Products; a United Dominion Company.
 - d. Curries Company.
 - e. Kewanee Corporation (The).
 - f. Pioneer Industries Inc.
 - g. Republic Builders Products.
 - h. Steelcraft; a division of Ingersoll-Rand.

2.2 MATERIALS

- A. Hot-Rolled Steel Sheets: ASTM A 569/A 569M, Commercial Steel (CS), Type B; free of scale, pitting, or surface defects; pickled and oiled.

- B. Cold-Rolled Steel Sheets: ASTM A 366/A 366M, Commercial Steel (CS), or ASTM A 620/A 620M, Drawing Steel (DS), Type B; stretcher-leveled standard of flatness.

2.3 DOORS

- A. General: Provide doors of sizes, thicknesses, and designs indicated.
- B. Interior Doors: Provide doors complying with requirements indicated below by referencing ANSI 250.8 for level and model and ANSI A250.4 for physical-endurance level:
 - 1. Level 2 and Physical Performance Level B (Heavy Duty), Model 1 (Full Flush).
- C. Exterior Doors: Provide doors complying with requirements indicated below by referencing ANSI A250.8 for level and model and ANSI A250.4 for physical-endurance level:
 - 1. Level 3 and Physical Performance Level A (Extra Heavy Duty), Model 1 (Full Flush).

2.4 FRAMES

- A. General: Provide steel frames for doors, transoms, sidelights, borrowed lights, and other openings that comply with ANSI A250.8 and with details indicated for type and profile. Conceal fastenings, unless otherwise indicated.
- B. Frames of 0.053-inch- thick steel sheet for:
 - 1. Level 2 steel doors.
 - 2. Wood doors where indicated.
- C. Hinge Reinforcements: High frequency hinge reinforcements are to be installed on all hollow metal frames in this project, as follows:
 - 1. Provide 7 ga. hinge reinforcement, projection welded to the frame at the factory.
 - 2. Form 10 ga. auxiliary hinge reinforcement to match contour of door frame.
 - 3. Arc weld the auxiliary hinge reinforcement to the standard hinge reinforcement and to the frame in 3 locations.
- D. Door Silencers: Except on weather-stripped frames, fabricate stops to receive three silencers on strike jambs of single-door frames and two silencers on heads of double-door frames.
- E. Supports and Anchors: Fabricated from not less than 0.042-inch- thick, electrolytic zinc-coated or metallic-coated steel sheet.
 - 1. Wall Anchors in Masonry Construction: 0.177-inch- diameter, steel wire complying with ASTM A 510 (ASTM A 510M) may be used in place of steel sheet.
- F. Inserts, Bolts, and Fasteners: Manufacturer's standard units. Where zinc-coated items are to be built into exterior walls, comply with ASTM A 153/A 153M, Class C or D as applicable.

2.5 PERFORMANCE REQUIREMENTS

- A. Fire-Rated Assemblies: Complying with NFPA 80 and listed and labeled by a qualified testing agency acceptable to authorities having jurisdiction for fire-protection ratings indicated, based on testing at positive pressure according to NFPA 252 or UL 10C.
 - 1. Smoke- and Draft-Control Assemblies: Provide assemblies with gaskets listed and labeled for smoke and draft control by a qualified testing agency acceptable to authorities having jurisdiction, based on testing according to UL 1784 and installed in compliance with NFPA 105.
 - 2. Oversize Fire-Rated Door Assemblies: For units exceeding sizes of tested assemblies, provide certification by a qualified testing agency that doors comply with standard construction requirements for tested and labeled fire-rated door assemblies except for size.
- B. Fire-Rated, Borrowed-Lite Assemblies: Complying with NFPA 80 and listed and labeled by a qualified testing agency acceptable to authorities having jurisdiction, for fire-protection ratings indicated, based on testing according to NFPA 257 or UL 9.

2.6 FABRICATION

- A. General: Fabricate steel door and frame units to comply with ANSI A250.8 and to be rigid, neat in appearance, and free from defects including warp and buckle. Where practical, fit and assemble units in manufacturer's plant. Clearly identify work that cannot be permanently factory assembled before shipment, to assure proper assembly at Project site.
- B. Exterior Door Construction: For exterior locations and elsewhere as indicated, fabricate doors, panels, and frames from metallic-coated steel sheet. Close top and bottom edges of doors flush as an integral part of door construction or by addition of 0.053-inch-thick, metallic-coated steel channels with channel webs placed even with top and bottom edges.
- C. Interior Door Faces: Fabricate exposed faces of doors and panels, including stiles and rails of nonflush units, from the following material:
 - 1. Cold-rolled steel sheet.
- D. Core Construction: Manufacturer's standard core construction that produces a door complying with SDI standards.
- E. Clearances for Non-Fire-Rated Doors: Not more than 1/8 inch at jambs and heads, except not more than 1/4 inch between pairs of doors. Not more than 3/4 inch at bottom.
- F. Clearances for Fire-Rated Doors: As required by NFPA 80.
- G. Single-Acting, Door-Edge Profile: Square edge.
- H. Tolerances: Comply with SDI 117, "Manufacturing Tolerances for Standard Steel Doors and Frames."
- I. Fabricate concealed stiffeners, reinforcement, edge channels, louvers, and moldings from either cold- or hot-rolled steel sheet.

- J. Hardware Preparation: Prepare doors and frames to receive mortised and concealed hardware according to final door hardware schedule and templates provided by hardware supplier. Comply with applicable requirements in ANSI A250.6 and ANSI A115 Series specifications for door and frame preparation for hardware.
- K. Frame Construction: Fabricate frames to shape shown.
 - 1. Fabricate frames with mitered or coped and continuously welded corners.
 - 2. For exterior applications, fabricate frames with mitered or coped and continuously welded corners and seamless face joints.
 - 3. Provide welded frames with temporary spreader bars.
- L. Reinforce doors and frames to receive surface-applied hardware. Drilling and tapping for surface-applied hardware may be done at Project site.
- M. Locate hardware as indicated on Shop Drawings or, if not indicated, according to ANSI A250.8.
- N. Glazing Stops: Manufacturer's standard, formed from 0.032-inch- (0.8-mm-) thick steel sheet.
 - 1. Provide screw-applied, removable, glazing stops on inside of glass, louvers, and other panels in doors.
- O. Astragals: As required by NFPA 80 to provide fire ratings indicated.

2.7 FINISHES

- A. Prime Finish: Manufacturer's standard, factory-applied coat of rust-inhibiting primer complying with ANSI A250.10 for acceptance criteria.

PART 3 - EXECUTION

3.1 INSTALLATION

- A. General: Install steel doors, frames, and accessories according to Shop Drawings, manufacturer's data, and as specified.
- B. Placing Frames: Comply with provisions in SDI 105, unless otherwise indicated. Set frames accurately in position, plumbed, aligned, and braced securely until permanent anchors are set. After wall construction is completed, remove temporary braces and spreaders, leaving surfaces smooth and undamaged.
 - 1. Except for frames located in existing walls or partitions, place frames before construction of enclosing walls and ceilings.
 - 2. In masonry construction, provide at least three wall anchors per jamb; install adjacent to hinge location on hinge jamb and at corresponding heights on strike jamb. Acceptable anchors include masonry wire anchors and masonry T-shaped anchors.
 - 3. In metal-stud partitions, provide at least three wall anchors per jamb; install adjacent to hinge location on hinge jamb and at corresponding heights on strike jamb. Attach wall anchors to studs with screws.
 - 4. Install fire-rated frames according to NFPA 80.

- C. Door Installation: Comply with ANSI A250.8. Fit hollow-metal doors accurately in frames, within clearances specified in ANSI A250.8. Shim as necessary to comply with SDI 122 and ANSI/DHI A115.1G.
 - 1. Fire-Rated Doors: Install within clearances specified in NFPA 80.

3.2 ADJUSTING AND CLEANING

- A. Prime-Coat Touchup: Immediately after installation, sand smooth any rusted or damaged areas of prime coat and apply touch up of compatible air-drying primer.

END OF SECTION 08 1113

SECTION 083323 - OVERHEAD COILING DOORS**PART 1 - GENERAL****1.1 RELATED DOCUMENTS**

- A. Drawings and general provisions of the Contract, including General and Supplementary Conditions and Division 1 Specification Sections, apply to this Section.

1.2 SUMMARY

- A. This Section includes the following types of overhead coiling doors:
 - 1. Counter doors in Kitchen / Serving areas.

1.3 DEFINITIONS

- A. Operation Cycle: One complete cycle of a door begins with the door in the closed position. The door is then moved to the open position and back to the closed position.

1.4 PERFORMANCE REQUIREMENTS

- A. Structural Performance: Provide overhead coiling doors capable of withstanding the effects of gravity loads.
- B. Operation-Cycle Requirements: Provide overhead coiling door components and operators capable of operating for not less than 10,000 cycles.

1.5 SUBMITTALS

- A. Product Data: For each type and size of overhead coiling door and accessory. Include details of construction relative to materials, dimensions of individual components, profiles, and finishes. Provide roughing-in diagrams, operating instructions, and maintenance information. Include the following:
 - 1. Setting drawings, templates, and installation instructions for built-in or embedded anchor devices.
 - 2. Motors: Show nameplate data and ratings; characteristics; mounting arrangements; size and location of winding termination lugs, conduit entry, and grounding lug; and coatings.
- B. Shop Drawings: For special components and installations not dimensioned or detailed in manufacturer's data sheets.
 - 1. Wiring Diagrams: Detail wiring for power, signal, and control systems. Differentiate between manufacturer-installed and field-installed wiring and between components provided by door manufacturer and those provided by others.
- C. Samples for Initial Selection: Manufacturer's color charts showing the full range of colors available for units with factory-applied finishes.

1.6 QUALITY ASSURANCE

- A. Installer Qualifications: Engage an experienced installer who is an authorized representative of the overhead coiling door manufacturer for both installation and maintenance of units required for this Project.

- B. Source Limitations: Obtain overhead coiling doors through one source from a single manufacturer.
 - 1. Obtain operators and controls from the overhead coiling door manufacturer.

PART 2 - PRODUCTS

2.1 MANUFACTURERS

- A. Manufacturer: Subject to compliance with requirements, provide products by one of the following:
 - 1. Alpine Overhead Doors, Inc.
 - 2. The Cookson Company.
 - 3. Overhead Door Corporation.
 - 4. Roll-Lite Door Corp.; Div. of Clopay Building Products Co.
 - 5. Wayne-Dalton Corp.

2.2 DOOR CURTAIN MATERIALS AND CONSTRUCTION

- A. Door Curtain: Fabricate overhead coiling door curtain of interlocking slats, designed to withstand wind loading indicated, in a continuous length for width of door without splices. Unless otherwise indicated, provide slats of material thickness recommended by door manufacturer for performance, size, and type of door indicated, and as follows:
 - 1. Aluminum Door Curtain Slats: ASTM B 209 or ASTM B 221, alloy and temper recommended by aluminum producer and finisher for type of use and finish indicated.
 - a. Aluminum Extrusion Thickness: Not less than 0.051 inch.
 - b. Flat profile slats.
 - 2. Inside Curtain Slat Face: To match material of outside metal curtain slat.
- B. Endlocks for Counter Doors: Manufacturer's standard locks on not less than alternate curtain slats for curtain alignment and resistance against lateral movement.
- C. Bottom Bar for Counter Doors: Manufacturer's standard continuous channel or tubular shape, aluminum extrusions to suit type of curtain slats.
 - 1. Astragal: Provide a replaceable, adjustable, continuous, compressible gasket of flexible vinyl, rubber, or neoprene; for placement between angles or fitted to shape, as a cushion bumper for interior door.
- D. Curtain Jamb Guides for Counter Doors: Fabricate curtain jamb guides of material and finish to match curtain slats, with sufficient depth and strength to retain curtain, to allow curtain to operate smoothly, and to withstand loading. Provide continuous integral wear strips to prevent metal-to-metal contact and minimize noise of travel and removable stops on guides to prevent over-travel of curtain.

2.3 HOODS AND ACCESSORIES

- A. Hood: Form to entirely enclose coiled curtain and operating mechanism at opening head and act as weatherseal. Contour to suit end brackets to which hood is attached. Roll and reinforce top and bottom edges for stiffness. Provide closed ends for surface-mounted hoods and fascia for any portion of between-jamb mounting projecting beyond wall face. Provide intermediate support brackets as required to prevent sag.
 - 1. Fabricate hoods for aluminum doors, alloy and temper recommended by aluminum producer and finisher for type of use and finish indicated; 0.032-inch minimum thickness, complying with ASTM B 209.
 - 2. Shape: Square.

- B. Push/Pull Handles: For push-up-operated on small counter door, provide lifting handles on each side of door.
 - 1. Provide pull-down straps or pole hooks for doors more than 84 inches (2130 mm) high.
- C. Slide Bolt: Fabricate with side-locking bolts to engage through slots in tracks for locking by padlock, located on both left and right jamb sides, operable from coil side.
- D. Chain Lock Keeper: Suitable for padlock.
- E. If door unit is power operated, provide safety interlock switch to disengage power supply when door is locked.

2.4 COUNTERBALANCING MECHANISM

- A. General: Counterbalance doors by means of adjustable-tension steel helical torsion spring, mounted around a steel shaft and contained in a spring barrel connected to door curtain with required barrel rings. Use grease-sealed bearings or self-lubricating graphite bearings for rotating members.
- B. Counterbalance Barrel: Fabricate spring barrel of hot-formed, structural-quality, welded or seamless carbon-steel pipe, of sufficient diameter and wall thickness to support rolled-up curtain without distortion of slats and to limit barrel deflection to not more than 0.03 in./ft. of span under full load.
- C. Provide spring balance of one or more oil-tempered, heat-treated steel helical torsion springs. Size springs to counterbalance weight of curtain, with uniform adjustment accessible from outside barrel. Provide cast-steel barrel plugs to secure ends of springs to barrel and shaft.
- D. Fabricate torsion rod for counterbalance shaft of cold-rolled steel, sized to hold fixed spring ends and carry torsional load.
- E. Brackets: Provide mounting brackets of manufacturer's standard design, either cast-iron or cold-rolled steel plate with bell-mouth guide groove for curtain.

2.5 ELECTRIC DOOR OPERATORS

- A. General: Provide electric door operator assembly of size and capacity recommended and provided by door manufacturer for door and operation-cycle requirements specified, with electric motor and factory-rewired motor controls, starter, gear-reduction unit, solenoid-operated brake, clutch, remote-control stations, control devices, integral gearing for locking door, and accessories required for proper operation.
- B. Comply with NFPA 70.
- C. Disconnect Device: Provide hand-operated disconnect or mechanism for automatically engaging chain and sprocket operator and releasing brake for emergency manual operation while disconnecting motor without affecting timing of limit switch. Mount disconnect and operator so they are accessible from floor level where approved by the architect. Include interlock device to automatically prevent motor from operating when emergency operator is engaged.
- D. Design operator so motor may be removed without disturbing limit-switch adjustment and without affecting emergency auxiliary operator.
- E. Provide control equipment complying with NEMA ICS 1, NEMA ICS 2, and NEMA ICS 6, with NFPA 70 Class 2 control circuit, maximum 24-V, ac or dc.

- F. Door-Operator Type: Provide wall-, hood-, or bracket-mounted, jackshaft-type door operator unit consisting of electric motor, drive, and chain and sprocket secondary drive.
- G. Electric Motors: Provide high-starting torque, reversible, continuous-duty, Class A insulated, electric motors complying with NEMA MG 1; with overload protection; sized to start, accelerate, and operate door in either direction from any position, at not less than 2/3 fps and not more than 1 fps, without exceeding nameplate ratings or service factor.
 - 1. Type: Polyphase, medium-induction type.
 - 2. Service Factor: According to NEMA MG 1, unless otherwise indicated.
 - 3. Coordinate wiring requirements and electrical characteristics of motors with building electrical system.
 - 4. Provide open dripproof-type motor, and controller with NEMA ICS 6, Type 1 enclosure.
- H. Limit Switches: Provide adjustable switches, interlocked with motor controls and set to automatically stop door at fully opened and fully closed positions.

2.6 FINISHES, GENERAL

- A. General: Comply with NAAMM's "Metal Finishes Manual for Architectural and Metal Products" for recommendations for applying and designating finishes.
- B. Appearance of Finished Work: Variations in appearance of abutting or adjacent pieces are acceptable if they are within one-half of the range of approved Samples. Noticeable variations in the same piece are not acceptable. Variations in appearance of other components are acceptable if they are within the range of approved Samples and are assembled or installed to minimize contrast.

2.7 ALUMINUM FINISHES

- A. Finish designations prefixed by AA comply with the system established by the Aluminum Association for designating aluminum finishes.
- B. Manufacturer's standard mill finish.
- C. Class II, Clear Anodic Finish: AA-M12C22A31 (Mechanical Finish: nonspecular as fabricated; Chemical Finish: etched, medium matte; Anodic Coating: Architectural Class II, clear coating 0.010 mm or thicker) complying with AAMA 611.

PART 3 - EXECUTION

3.1 INSTALLATION

- A. General: Install door and operating equipment complete with necessary hardware, jamb and head mold strips, anchors, inserts, hangers, and equipment supports according to Shop Drawings, manufacturer's written instructions, and as specified.

3.2 ADJUSTING

- A. Lubricate bearings and sliding parts; adjust doors to operate easily, free from warp, twist, or distortion.

3.3 DEMONSTRATION

- A. Startup Services: Engage a factory-authorized service representative to perform startup services and to train Owner's maintenance personnel as specified below:

1. Test and adjust controls and safeties. Replace damaged and malfunctioning controls and equipment.
 - a. Test door closing when activated by detector or alarm connected fire-release system. Reset door-closing mechanism after successful test.
2. Train Owner's maintenance personnel on procedures and schedules related to startup and shutdown, troubleshooting, servicing, preventive maintenance, and procedures for testing and resetting release devices.
3. Schedule training with Owner with at least 7 days' advance notice.

END OF SECTION 083323

SECTION 08 4113 - ALUMINUM-FRAMED ENTRANCES AND STOREFRONTS

PART 1 - GENERAL

1.1 RELATED DOCUMENTS

- A. Drawings and general provisions of the Contract, including General and Supplementary Conditions and Division 01 Specification Sections, apply to this Section.

1.2 SUMMARY

- A. Section Includes:
 - 1. Aluminum-framed storefront systems.
 - 2. Aluminum-framed entrance door systems.
 - 3. Fixed windows.

1.3 ACTION SUBMITTALS

- A. Product Data: For each type of product.
 - 1. Include construction details, material descriptions, dimensions of individual components and profiles, and finishes.
- B. Shop Drawings: For aluminum-framed entrances and storefronts. Include plans, elevations, sections, full-size details, and attachments to other work.
 - 1. Include details of provisions for assembly expansion and contraction and for draining moisture occurring within the assembly to the exterior.
 - 2. Include full-size isometric details of each type of vertical-to-horizontal intersection of aluminum-framed entrances and storefronts, showing the following:
 - a. Joinery, including concealed welds.
 - b. Anchorage.
 - c. Expansion provisions.
 - d. Glazing.
 - e. Flashing and drainage.
 - 3. Show connection to and continuity with adjacent thermal, weather, air, and vapor barriers.
 - 4. Include point-to-point wiring diagrams showing the following:
 - a. Power requirements for each electrically operated door hardware.
 - b. Location and types of switches, signal device, conduit sizes, and number and size of wires.
- C. Samples for Initial Selection: For units with factory-applied color finishes.

- D. Samples for Verification: For each type of exposed finish required, in manufacturer's standard sizes.
- E. Fabrication Sample: Of each vertical-to-horizontal intersection of assemblies, made from 12-inch lengths of full-size components and showing details of the following:
 - 1. Joinery, including concealed welds.
 - 2. Anchorage.
 - 3. Expansion provisions.
 - 4. Glazing.
 - 5. Flashing and drainage.
- F. Entrance Door Hardware Schedule: Prepared by or under supervision of supplier, detailing fabrication and assembly of entrance door hardware, as well as procedures and diagrams. Coordinate final entrance door hardware schedule with doors, frames, and related work to ensure proper size, thickness, hand, function, and finish of entrance door hardware.
- G. Delegated-Design Submittal: For aluminum-framed entrances and storefronts including analysis data signed and sealed by the qualified professional engineer responsible for their preparation.

1.4 INFORMATIONAL SUBMITTALS

- A. Preconstruction Laboratory Mockup Testing Submittals:
 - 1. Testing Program: Developed specifically for Project.
 - 2. Test Reports: Prepared by a qualified preconstruction testing agency for each mockup test.
 - 3. Record Drawings: As-built drawings of preconstruction laboratory mockups showing changes made during preconstruction laboratory mockup testing.
- B. Qualification Data:
 - 1. For Installer.
 - 2. For professional engineer's experience with providing delegated-design engineering services of the kind indicated, including documentation that engineer is licensed in the state in which Project is located.
- C. Energy Performance Certificates: For aluminum-framed entrances and storefronts, accessories, and components, from manufacturer.
 - 1. Basis for Certification: NFRC-certified energy performance values for each aluminum-framed entrance and storefront.
- D. Product Test Reports: For aluminum-framed entrances and storefronts, for tests performed by a qualified testing agency.
- E. Quality-Control Program: Developed specifically for Project, including fabrication and installation, according to recommendations in ASTM C1401. Include periodic quality-control reports.

- F. Source quality-control reports.
- G. Field quality-control reports.
- H. Sample Warranties: For special warranties.

1.5 CLOSEOUT SUBMITTALS

- A. Maintenance Data: For aluminum-framed entrances and storefronts to include in maintenance manuals.
- B. Maintenance Data for Structural Sealant: For structural-sealant-glazed storefront to include in maintenance manuals. Include ASTM C1401 recommendations for post-installation-phase quality-control program.

1.6 QUALITY ASSURANCE

- A. Installer Qualifications: An entity that employs installers and supervisors who are trained and approved by manufacturer.
- B. Laboratory Mockup Testing Agency Qualifications: Qualified according to ASTM E699 for testing indicated and accredited by the International Accreditation Service or the International Laboratory Accreditation Cooperation Mutual Recognition Arrangement as complying with ISO/IEC 17025.
- C. Testing Agency Qualifications: Qualified according to ASTM E699 for testing indicated and accredited by the International Accreditation Service or the International Laboratory Accreditation Cooperation Mutual Recognition Arrangement as complying with ISO/IEC 17025 and acceptable to Owner and Architect.
- D. Product Options: Information on Drawings and in Specifications establishes requirements for aesthetic effects and performance characteristics of assemblies. Aesthetic effects are indicated by dimensions, arrangements, alignment, and profiles of components and assemblies as they relate to sightlines, to one another, and to adjoining construction.
 - 1. Do not change intended aesthetic effects, as judged solely by Architect, except with Architect's approval. If changes are proposed, submit comprehensive explanatory data to Architect for review.
- E. Structural-Sealant Glazing: Comply with ASTM C1401 for design and installation of storefront systems that include structural glazing.

1.7 WARRANTY

- A. Special Warranty: Manufacturer agrees to repair or replace components of aluminum-framed entrances and storefronts that do not comply with requirements or that fail in materials or workmanship within specified warranty period.
 - 1. Failures include, but are not limited to, the following:

- a. Structural failures, including, but not limited to, excessive deflection.
 - b. Noise or vibration created by wind and thermal and structural movements.
 - c. Deterioration of metals, metal finishes, and other materials beyond normal weathering.
 - d. Water penetration through fixed glazing and framing areas.
 - e. Failure of operating components.
2. Warranty Period: Five years from date of Substantial Completion.
- B. Special Finish Warranty, Factory-Applied Finishes: Standard form in which manufacturer agrees to repair finishes or replace aluminum that shows evidence of deterioration of factory-applied finishes within specified warranty period.
1. Deterioration includes, but is not limited to, the following:
 - a. Color fading more than 5 Delta E units when tested according to ASTM D2244.
 - b. Chalking in excess of a No. 8 rating when tested according to ASTM D4214.
 - c. Cracking, checking, peeling, or failure of paint to adhere to bare metal.
 2. Warranty Period: Five years from date of Substantial Completion.
- C. Special Finish Warranty, Anodized Finishes: Standard form in which manufacturer agrees to repair finishes or replace aluminum that shows evidence of deterioration of anodized finishes within specified warranty period.
1. Deterioration includes, but is not limited to, the following:
 - a. Color fading more than 5 Delta E units when tested according to ASTM D 2244.
 - b. Chalking in excess of a No. 8 rating when tested according to ASTM D 4214.
 - c. Cracking, peeling, or chipping.
 2. Warranty Period: Five years from date of Substantial Completion.

PART 2 - PRODUCTS

2.1 MANUFACTURERS

- A. Source Limitations: Obtain all components of aluminum-framed entrance and storefront system, including framing, spandrel panels, and accessories, from single manufacturer.

2.2 PERFORMANCE REQUIREMENTS

- A. Delegated Design: Engage a qualified professional engineer, as defined in Section 01 4000 "Quality Requirements," to design aluminum-framed entrances and storefronts.
- B. General Performance: Comply with performance requirements specified, as determined by testing of aluminum-framed entrances and storefronts representing those indicated

for this Project without failure due to defective manufacture, fabrication, installation, or other defects in construction.

1. Aluminum-framed entrances and storefronts shall withstand movements of supporting structure, including, but not limited to, twist, column shortening, long-term creep, and deflection from uniformly distributed and concentrated live loads.
2. Failure also includes the following:
 - a. Thermal stresses transferring to building structure.
 - b. Glass breakage.
 - c. Noise or vibration created by wind and thermal and structural movements.
 - d. Loosening or weakening of fasteners, attachments, and other components.
 - e. Failure of operating units.

C. Structural Loads:

1. Wind Loads: As indicated on Drawings.
2. Other Design Loads: As indicated on Drawings.

D. Deflection of Framing Members: At design wind pressure, as follows:

1. Deflection Normal to Wall Plane: Limited to edge of glass in a direction perpendicular to glass plane not exceeding 1/175 of the glass edge length for each individual glazing lite or an amount that restricts edge deflection of individual glazing lites to 3/4 inch, whichever is less.
2. Deflection Parallel to Glazing Plane: Limited to amount not exceeding that which reduces glazing bite to less than 75 percent of design dimension and that which reduces edge clearance between framing members and glazing or other fixed components to less than 1/8 inch.
 - a. Operable Units: Provide a minimum 1/16-inch clearance between framing members and operable units.
3. Cantilever Deflection: Where framing members overhang an anchor point, as follows:
 - a. Perpendicular to Plane of Wall: No greater than 1/240 of clear span plus 1/4 inch for spans greater than 11 feet 8-1/4 inches or 1/175 times span, for spans of less than 11 feet 8-1/4 inches.

E. Structural: Test according to ASTM E330/E330M as follows:

1. When tested at positive and negative wind-load design pressures, storefront assemblies, including entrance doors, do not evidence deflection exceeding specified limits.
2. When tested at 150 percent of positive and negative wind-load design pressures, storefront assemblies, including entrance doors and anchorage, do not evidence material failures, structural distress, or permanent deformation of main framing members exceeding 0.2 percent of span.
3. Test Durations: As required by design wind velocity, but not less than 10 seconds.

F. Water Penetration under Static Pressure: Test according to ASTM E331 as follows:

1. No evidence of water penetration through fixed glazing and framing areas, including entrance doors, when tested according to a minimum static-air-pressure differential of 20 percent of positive wind-load design pressure, but not less than 10 lbf/sq. ft.
- G. Water Penetration under Dynamic Pressure: Test according to AAMA 501.1 as follows:
1. No evidence of water penetration through fixed glazing and framing areas when tested at dynamic pressure equal to 20 percent of positive wind-load design pressure, but not less than 10 lbf/sq. ft.
 2. Maximum Water Leakage: According to AAMA 501.1. Water leakage does not include water controlled by flashing and gutters, or water that is drained to exterior.
- H. Seismic Performance: Aluminum-framed entrances and storefronts shall withstand the effects of earthquake motions determined according to ASCE/SEI 7.
1. Seismic Drift Causing Glass Fallout: Complying with criteria for passing based on building occupancy type when tested according to AAMA 501.6 at design displacement and 1.5 times the design displacement.
- I. Energy Performance: Certified and labeled by manufacturer for energy performance as follows:
1. Thermal Transmittance (U-factor):
 - a. Fixed Glazing and Framing Areas: U-factor for the system of not more than 0.69 Btu/sq. ft. x h x deg F as determined according to NFRC 100.
 - b. Entrance Doors: U-factor of not more than 0.68 Btu/sq. ft. x h x deg F as determined according to NFRC 100.
 2. Solar Heat-Gain Coefficient (SHGC):
 - a. Fixed Glazing and Framing Areas: SHGC for the system of not more than 0.45 as determined according to NFRC 200.
 - b. Entrance Doors: SHGC of not more than 0.45 as determined according to NFRC 200.
 3. Air Leakage:
 - a. Fixed Glazing and Framing Areas: Air leakage for the system of not more than 0.06 cfm/sq. ft. at a static-air-pressure differential of 6.24 lbf/sq. ft. when tested according to ASTM E283.
 - b. Entrance Doors: Air leakage of not more than 1.0 cfm/sq. ft. at a static-air-pressure differential of 1.57 lbf/sq. ft..
 4. Condensation Resistance Factor (CRF):
 - a. Fixed Glazing and Framing Areas: CRF for the system of not less than 70 as determined according to AAMA 1503.
 - b. Entrance Doors: CRF of not less than 68 as determined according to AAMA 1503.
 - c. Venting Windows: Whole window CRF of not less than 55 as determined according to AAMA 1503.

- J. Noise Reduction: Test according to ASTM E90, with ratings determined by ASTM E1332, as follows.
 - 1. Outdoor-Indoor Transmission Class: Minimum 30.
- K. Blast Resistance:
 - 1. Hazard Rating: Minimal Hazard according to ASTM F2912.
 - 2. Performance Condition: 2 according to GSA-TS01.
- L. Windborne-Debris Impact Resistance: Passes ASTM E1886 missile-impact and cyclic-pressure tests in accordance with ASTM E1996 for Wind Zone 3 protection.
 - 1. Large-Missile Test: For glazing located within 30 feet of grade.
 - 2. Small-Missile Test: For glazing located between 30 feet and 60 feet above grade.
- M. Thermal Movements: Allow for thermal movements resulting from ambient and surface temperature changes.
 - 1. Temperature Change: 120 deg F, ambient; 180 deg F, material surfaces.
 - 2. Thermal Cycling: No buckling; stress on glass; sealant failure; excess stress on framing, anchors, and fasteners; or reduction of performance when tested according to AAMA 501.5.
 - a. High Exterior Ambient-Air Temperature: That which produces an exterior metal-surface temperature of 180 deg F.
 - b. Low Exterior Ambient-Air Temperature: 0 deg F.
 - c. Interior Ambient-Air Temperature: 75 deg F.
- N. Structural-Sealant Joints:
 - 1. Designed to carry gravity loads of glazing.
- O. Structural Sealant: ASTM C1184. Capable of withstanding tensile and shear stresses imposed by structural-sealant-glazed, aluminum-framed entrances and storefronts without failing adhesively or cohesively. When tested for preconstruction adhesion and compatibility, cohesive failure of sealant shall occur before adhesive failure.
 - 1. Adhesive failure occurs when sealant pulls away from substrate cleanly, leaving no sealant material behind.
 - 2. Cohesive failure occurs when sealant breaks or tears within itself but does not separate from each substrate, because sealant-to-substrate bond strength exceeds sealant's internal strength.

2.3 STOREFRONT SYSTEMS

- A. Manufacturers: Subject to compliance with requirements, provide products by one of the following:
 - 1. Arcadia, Inc.
 - 2. EFCO Corporation.
 - 3. Kawneer North America, an Arconic company.

4. U.S. Aluminum; a brand of C.R. Laurence.
- B. Framing Members: Manufacturer's extruded- or formed-aluminum framing members of thickness required and reinforced as required to support imposed loads.
1. Exterior Framing Construction: Thermally broken (overall frame size: 2' X 4 ½").
 2. Interior Vestibule Framing Construction: Nonthermal.
 3. Glazing System: Retained mechanically with gaskets on four sides at a few window types and locations as indicated on drawings. Retained mechanically with gaskets on two sides and structural sealant on two sides at a few locations as indicated on drawings.
 4. Glazing Plane: Front.
 5. Finish: Baked-enamel or powder-coat finish.
 6. Fabrication Method: Field-fabricated stick system.
 7. Aluminum: Alloy and temper recommended by manufacturer for type of use and finish indicated.
 8. Steel Reinforcement: As required by manufacturer.
- C. Backer Plates: Manufacturer's standard, continuous backer plates for framing members, if not integral, where framing abuts adjacent construction.
- D. Brackets and Reinforcements: Manufacturer's standard high-strength aluminum with nonstaining, nonferrous shims for aligning system components.

2.4 ENTRANCE DOOR SYSTEMS

- A. Manufacturers: Subject to compliance with requirements, provide products by one of the following:
1. Arcadia, Inc.
 2. EFCO Corporation.
 3. Kawneer North America, an Arconic company.
 4. U.S. Aluminum; a brand of C.R. Laurence.
- B. Entrance Doors: Manufacturer's standard glazed entrance doors for manual-swing or automatic operation.
1. Door Construction: 1-3/4-inch overall thickness, with minimum 0.125-inch thick, extruded-aluminum tubular rail and stile members. Mechanically fasten corners with reinforcing brackets that are deeply penetrated and fillet welded or that incorporate concealed tie rods.
 - a. Thermal Construction: High-performance plastic connectors separate aluminum members exposed to the exterior from members exposed to the interior] <Insert description.
 2. Door Design: Wide stile; 5-inch nominal width.
 3. Glazing Stops and Gaskets: Beveled, snap-on, extruded-aluminum stops and preformed gaskets.
 - a. Provide nonremovable glazing stops on outside of door.

4. Finish: Match adjacent storefront framing finish.

2.5 ENTRANCE DOOR HARDWARE

- A. Entrance Door Hardware: Hardware not specified in this Section is specified in Section 08 7100 "Door Hardware."
- B. General: Provide entrance door hardware and entrance door hardware sets indicated in door and frame schedule for each entrance door, to comply with requirements in this Section.
 1. Entrance Door Hardware Sets: Provide quantity, item, size, finish or color indicated, and products equivalent in function and comparable in quality to named products.
 2. Sequence of Operation: Provide electrified door hardware function, sequence of operation, and interface with other building control systems indicated.
 3. Opening-Force Requirements:
 - a. Egress Doors: Not more than 15 lbf to release the latch and not more than 30 lbf to set the door in motion and not more than 15 lbf to open the door to its minimum required width.
 - b. Accessible Interior Doors: Not more than 5 lbf to fully open door.
- C. Designations: Requirements for design, grade, function, finish, quantity, size, and other distinctive qualities of each type of entrance door hardware are indicated in "Entrance Door Hardware Sets" Article. Products are identified by using entrance door hardware designations as follows:
 1. Named Manufacturers' Products: Manufacturer and product designation are listed for each door hardware type required for the purpose of establishing minimum requirements. Manufacturers' names are abbreviated in "Entrance Door Hardware Sets" Article.
 2. References to BHMA Standards: Provide products complying with these standards and requirements for description, quality, and function.
- D. Pivot Hinges: BHMA A156.4, Grade 1.
 1. Offset-Pivot Hinges: Provide top, bottom, and intermediate offset pivots at each door leaf.
- E. Butt Hinges: BHMA A156.1, Grade 1, radius corner.
 1. Nonremovable Pins: Provide setscrew in hinge barrel that, when tightened into a groove in hinge pin, prevents removal of pin while entrance door is closed.
 2. Exterior Hinges: Stainless steel, with stainless-steel pin.
 3. Quantities:
 - a. For doors up to 87 inches high, provide three hinges per leaf.
 - b. For doors more than 87 and up to 120 inches high, provide four hinges per leaf.
- F. Continuous-Gear Hinges: BHMA A156.26.

- G. Mortise Auxiliary Locks: BHMA A156.5, Grade 1.
- H. Manual Flush Bolts: BHMA A156.16, Grade 1.
- I. Automatic and Self-Latching Flush Bolts: BHMA A156.3, Grade 1.
- J. Panic Exit Devices: BHMA A156.3, Grade 1, listed and labeled by a testing and inspecting agency acceptable to authorities having jurisdiction, for panic protection, based on testing according to UL 305.
- K. Cylinders:
 - 1. As specified in Section 08 7100 "Door Hardware."
 - 2. BHMA A156.5, Grade 1.
 - a. Keying: [No master] [Master] key system. Permanently inscribe each key with a visual key control number and include notation ["DO NOT DUPLICATE"] [to be furnished by Owner].
- L. Strikes: Provide strike with black-plastic dust box for each latch or lock bolt; fabricated for aluminum framing.
- M. Operating Trim: BHMA A156.6.
- N. Removable Mullions: BHMA A156.3 extruded aluminum.
 - 1. When used with panic exit devices, provide keyed removable mullions listed and labeled by a testing and inspecting agency acceptable to authorities having jurisdiction, for panic protection, based on testing according to UL 305. Use only mullions that have been tested with exit devices to be used.
- O. Closers: BHMA A156.4, Grade 1, with accessories required for a complete installation, sized as required by door size, exposure to weather, and anticipated frequency of use; adjustable to comply with field conditions and requirements for opening force.
- P. Concealed Overhead Holders and Stops: BHMA A156.8, Grade 1.
- Q. Door Stops: BHMA A156.16, Grade 1, floor or wall mounted, as appropriate for door location indicated, with integral rubber bumper.
- R. Weather Stripping: Manufacturer's standard replaceable components.
 - 1. Compression Type: Made of ASTM D2000 molded neoprene or ASTM D2287 molded PVC.
 - 2. Sliding Type: AAMA 701/702, made of wool, polypropylene, or nylon woven pile with nylon-fabric or aluminum-strip backing.
- S. Weather Sweeps: Manufacturer's standard exterior-door bottom sweep with concealed fasteners on mounting strip.
- T. Thresholds: BHMA A156.21 raised thresholds beveled with a slope of not more than 1:2, with maximum height of 1/2 inch.

- U. Finger Guards: Manufacturer's standard collapsible neoprene or PVC gasket anchored to frame hinge-jamb at center-pivoted doors.

2.6 GLAZING

- A. Glazing: Comply with Section 08 8000 "Glazing."
- B. Glazing Gaskets: Manufacturer's standard sealed-corner pressure-glazing system of black, resilient elastomeric glazing gaskets, setting blocks, and shims or spacers.
- C. Glazing Sealants: As recommended by manufacturer.
- D. Structural Glazing Sealants: ASTM C1184 chemically curing silicone formulation that is compatible with system components with which it comes in contact; specifically formulated and tested for use as structural sealant and approved by structural-sealant manufacturer for use in storefront system indicated.
 - 1. Color: As selected by Architect from manufacturer's full range of colors.
- E. Weatherseal Sealants: ASTM C920 for Type S; Grade NS; Class 25; Uses NT, G, A, and O; chemically curing silicone formulation that is compatible with structural sealant and other system components with which it comes in contact; recommended by structural-sealant, weatherseal-sealant, and structural-sealant-glazed storefront manufacturers for this use.
 - 1. Color: Match structural sealant.

2.7 MATERIALS

- A. Sheet and Plate: ASTM B209.
- B. Extruded Bars, Rods, Profiles, and Tubes: ASTM B221.
- C. Extruded Structural Pipe and Tubes: ASTM B429/B429M.
- D. Structural Profiles: ASTM B308/B308M.
- E. Steel Reinforcement:
 - 1. Structural Shapes, Plates, and Bars: ASTM A36/A36M.
 - 2. Cold-Rolled Sheet and Strip: ASTM A1008/A1008M.
 - 3. Hot-Rolled Sheet and Strip: ASTM A1011/A1011M.
- F. Steel Reinforcement Primer: Manufacturer's standard zinc-rich, corrosion-resistant primer complying with SSPC-PS Guide No. 12.00; applied immediately after surface preparation and pretreatment. Select surface preparation methods according to recommendations in SSPC-SP COM, and prepare surfaces according to applicable SSPC standard.

2.8 ACCESSORIES

- A. Automatic Door Operators: As indicated in Door Hardware.

- B. Fasteners and Accessories: Manufacturer's standard corrosion-resistant, nonstaining, nonbleeding fasteners and accessories compatible with adjacent materials.
 - 1. Use self-locking devices where fasteners are subject to loosening or turning out from thermal and structural movements, wind loads, or vibration.
 - 2. Reinforce members as required to receive fastener threads.
 - 3. Use exposed fasteners with countersunk Phillips screw heads , finished to match framing system.
- C. Anchors: Three-way adjustable anchors with minimum adjustment of 1 inch that accommodate fabrication and installation tolerances in material and finish compatible with adjoining materials and recommended by manufacturer.
 - 1. Concrete and Masonry Inserts: Hot-dip galvanized cast-iron, malleable-iron, or steel inserts complying with ASTM A123/A123M or ASTM A153/A153M requirements.
- D. Concealed Flashing: Manufacturer's standard corrosion-resistant, nonstaining, nonbleeding flashing compatible with adjacent materials.
- E. Bituminous Paint: Cold-applied asphalt-mastic paint containing no asbestos, formulated for 30-mil thickness per coat.
- F. Rigid PVC Filler.

2.9 FABRICATION

- A. Form or extrude aluminum shapes before finishing.
- B. Weld in concealed locations to greatest extent possible to minimize distortion or discoloration of finish. Remove weld spatter and welding oxides from exposed surfaces by descaling or grinding.
- C. Fabricate components that, when assembled, have the following characteristics:
 - 1. Profiles that are sharp, straight, and free of defects or deformations.
 - 2. Accurately fitted joints with ends coped or mitered.
 - 3. Physical and thermal isolation of glazing from framing members.
 - 4. Accommodations for thermal and mechanical movements of glazing and framing to maintain required glazing edge clearances.
 - 5. Provisions for field replacement of glazing from exterior.
 - 6. Fasteners, anchors, and connection devices that are concealed from view to greatest extent possible.
- D. Mechanically Glazed Framing Members: Fabricate for flush glazing without projecting stops.
- E. Structural-Sealant-Glazed Framing Members: Include accommodations for using temporary support device to retain glazing in place while structural sealant cures.
- F. Storefront Framing: Fabricate components for assembly using shear-block system.

- G. Entrance Door Frames: Reinforce as required to support loads imposed by door operation and for installing entrance door hardware.
 - 1. At interior and exterior doors, provide compression weather stripping at fixed stops.
- H. Entrance Doors: Reinforce doors as required for installing entrance door hardware.
 - 1. At pairs of exterior doors, provide sliding-type weather stripping retained in adjustable strip and mortised into door edge.
 - 2. At exterior doors, provide weather sweeps applied to door bottoms.
- I. Entrance Door Hardware Installation: Factory install entrance door hardware to the greatest extent possible. Cut, drill, and tap for factory-installed entrance door hardware before applying finishes.
- J. After fabrication, clearly mark components to identify their locations in Project according to Shop Drawings.

2.10 ALUMINUM FINISHES

- A. General: Comply with NAAMM's "Metal Finishes Manual for Architectural and Metal Products" for recommendations for applying and designating finishes.
- B. Finish designations prefixed by AA comply with the system established by the Aluminum Association for designating aluminum finishes.
- C. Class I, Clear, Anodic Finish: AA-M12C22A41 (Mechanical Finish: nonspecular as fabricated; Chemical Finish: etched, medium matte; Anodic Coating: Architectural Class I, clear coating 0.018 mm or thicker) complying with AAMA 611.

2.11 SOURCE QUALITY CONTROL

- A. Structural Sealant: Perform quality-control procedures complying with ASTM C1401 recommendations, including, but not limited to, assembly material qualification procedures, sealant testing, and assembly fabrication reviews and checks.

PART 3 - EXECUTION

3.1 EXAMINATION

- A. Examine areas, with Installer present, for compliance with requirements for installation tolerances and other conditions affecting performance of the Work.
- B. Proceed with installation only after unsatisfactory conditions have been corrected.

3.2 INSTALLATION, GENERAL

- A. Comply with manufacturer's written instructions.

- B. Do not install damaged components.
- C. Fit joints to produce hairline joints free of burrs and distortion.
- D. Rigidly secure nonmovement joints.
- E. Install anchors with separators and isolators to prevent metal corrosion and electrolytic deterioration and to prevent impeding movement of moving joints.
- F. Seal perimeter and other joints watertight unless otherwise indicated.
- G. Metal Protection:
 - 1. Where aluminum is in contact with dissimilar metals, protect against galvanic action by painting contact surfaces with materials recommended by manufacturer for this purpose or by installing nonconductive spacers.
 - 2. Where aluminum is in contact with concrete or masonry, protect against corrosion by painting contact surfaces with bituminous paint.
- H. Set continuous sill members and flashing in full sealant bed, as specified in Section 07 9200 "Joint Sealants," to produce weathertight installation.
- I. Install joint filler behind sealant as recommended by sealant manufacturer.
- J. Install components plumb and true in alignment with established lines and grades.

3.3 INSTALLATION OF OPERABLE UNITS

- A. Install operable units level and plumb, securely anchored, and without distortion. Adjust weather-stripping contact and hardware movement to produce proper operation.

3.4 INSTALLATION OF GLAZING

- A. Install glazing as specified in Section 08 8000 "Glazing."

3.5 INSTALLATION OF STRUCTURAL GLAZING

- A. Prepare surfaces that will contact structural sealant according to sealant manufacturer's written instructions, to ensure compatibility and adhesion. Preparation includes, but is not limited to, cleaning and priming surfaces.
- B. Set glazing into framing according to sealant manufacturer and framing manufacturer's written instructions and standard practice. Use a spacer or backer as recommended by manufacturer.
- C. Set glazing with proper orientation so that coatings face exterior or interior as specified.
- D. Hold glazing in place using temporary retainers of type and spacing recommended by manufacturer, until structural sealant joint has cured.

- E. Apply structural sealant to completely fill cavity, according to sealant manufacturer and framing manufacturer's written instructions and in compliance with local codes.
- F. Apply structural sealant at temperatures indicated by sealant manufacturer for type of sealant.
- G. Allow structural sealant to cure according to manufacturer's written instructions.
- H. Clean and protect glass as indicated in Section 08 8000 "Glazing."

3.6 INSTALLATION OF WEATHERSEAL SEALANT

- A. After structural sealant has completely cured, remove temporary retainers and insert backer rod between lites of glass as recommended by sealant manufacturer.
- B. Install weatherseal sealant to completely fill cavity, according to sealant manufacturer's written instructions, to produce weatherproof joints.

3.7 INSTALLATION OF ALUMINUM-FRAMED ENTRANCE DOORS

- A. Install entrance doors to produce smooth operation and tight fit at contact points.
 - 1. Exterior Doors: Install to produce weathertight enclosure and tight fit at weather stripping.
 - 2. Field-Installed Entrance Door Hardware: Install surface-mounted entrance door hardware according to entrance door hardware manufacturers' written instructions using concealed fasteners to greatest extent possible.

3.8 ERECTION TOLERANCES

- A. Install aluminum-framed entrances and storefronts to comply with the following maximum tolerances:
 - 1. Plumb: 1/8 inch in 10 feet; 1/4 inch in 40 feet.
 - 2. Level: 1/8 inch in 20 feet; 1/4 inch in 40 feet.
 - 3. Alignment:
 - a. Where surfaces abut in line or are separated by reveal or protruding element up to 1/2 inch wide, limit offset from true alignment to 1/16 inch.
 - b. Where surfaces are separated by reveal or protruding element from 1/2 to 1 inch wide, limit offset from true alignment to 1/8 inch.
 - c. Where surfaces are separated by reveal or protruding element of 1 inch wide or more, limit offset from true alignment to 1/4 inch.
 - 4. Location: Limit variation from plane to 1/8 inch in 12 feet; 1/2 inch over total length.

3.9 MAINTENANCE SERVICE

- A. Entrance Door Hardware Maintenance:

1. Maintenance Tools and Instructions: Furnish a complete set of specialized tools and maintenance instructions as needed for Owner's continued adjustment, maintenance, and removal and replacement of entrance door hardware.
2. Initial Maintenance Service: Beginning at Substantial Completion, provide six months' full maintenance by skilled employees of entrance door hardware Installer. Include quarterly preventive maintenance, repair or replacement of worn or defective components, lubrication, cleaning, and adjusting as required for proper entrance door hardware operation at rated speed and capacity. Use parts and supplies that are the same as those used in the manufacture and installation of original equipment.

3.10 ENTRANCE DOOR HARDWARE SETS

- A. Install hardware specified in Section 08 7100 "Door Hardware" and furnished by door hardware supplier.

END OF SECTION 08 4113

SECTION 087100 - DOOR HARDWARE**PART 1 - GENERAL****1.1 RELATED DOCUMENTS**

- A. Drawings and general provisions of the Contract, including General and Supplementary Conditions and Division 1 Specification Sections, apply to this Section.

1.2 SUMMARY

- A. This Section includes commercial door hardware for the following:
 - 1. Swinging doors.
 - 2. Sliding doors.
 - 3. Other doors to the extent indicated.
- B. Door hardware includes, but is not necessarily limited to, the following:
 - 1. Mechanical door hardware.
 - 2. Electromechanical door hardware, power supplies, back-ups and surge protection.
 - 3. Cylinders specified for doors in other sections.
- C. Related Sections:
 - 1. Division 08 Section "Door Hardware Schedule".
 - 2. Division 08 Section "Hollow Metal Doors and Frames".
 - 3. Division 08 Section "Interior Aluminum Doors and Frames".
 - 4. Division 08 Section "Flush Wood Doors".
 - 5. Division 08 Section "Access Control Hardware".
- D. Codes and References: Comply with the version year adopted by the Authority Having Jurisdiction.
 - 1. ANSI A117.1 - Accessible and Usable Buildings and Facilities.
 - 2. ICC/IBC - International Building Code.
 - 3. NFPA 80 - Fire Doors and Windows.
 - 4. NFPA 101 - Life Safety Code.
 - 5. NFPA 105 - Installation of Smoke Door Assemblies.
 - 6. State Building Codes, Local Amendments.
- E. Standards: All hardware specified herein shall comply with the following industry standards:
 - 1. ANSI/BHMA Certified Product Standards - A156 Series
 - 2. UL10C – Positive Pressure Fire Tests of Door Assemblies

1.3 SUBMITTALS

- A. Product Data: Manufacturer's product data sheets including installation details, material descriptions, dimensions of individual components and profiles, operational descriptions and finishes.
- B. Door Hardware Schedule: Prepared by or under the supervision of supplier, detailing fabrication and assembly of door hardware, as well as procedures and diagrams. Coordinate the final Door Hardware Schedule with doors, frames, and related work to ensure proper size, thickness, hand, function, and finish of door hardware.
 - 1. Format: Comply with scheduling sequence and vertical format in DHI's "Sequence and Format for the Hardware Schedule."
 - 2. Organization: Organize the Door Hardware Schedule into door hardware sets indicating complete designations of every item required for each door or opening. Organize door hardware sets in same order as in the Door Hardware Sets at the end of Part 3. Submittals that do not follow the same format and order as the Door Hardware Sets will be rejected and subject to resubmission.
 - 3. Content: Include the following information:
 - a. Type, style, function, size, label, hand, and finish of each door hardware item.
 - b. Manufacturer of each item.
 - c. Fastenings and other pertinent information.
 - d. Location of door hardware set, cross-referenced to Drawings, both on floor plans and in door and frame schedule.
 - e. Explanation of abbreviations, symbols, and codes contained in schedule.
 - f. Mounting locations for door hardware.
 - g. Door and frame sizes and materials.
 - 4. Submittal Sequence: Submit the final Door Hardware Schedule at earliest possible date, particularly where approval of the Door Hardware Schedule must precede fabrication of other work that is critical in the Project construction schedule. Include Product Data, Samples, Shop Drawings of other work affected by door hardware, and other information essential to the coordinated review of the Door Hardware Schedule.
- C. Shop Drawings: Details of electrified access control hardware indicating the following:
 - 1. Wiring Diagrams: Upon receipt of approved schedules, submit detailed system wiring diagrams for power, signaling, monitoring, communication, and control of the access control system electrified hardware. Differentiate between manufacturer-installed and field-installed wiring. Include the following:
 - a. Elevation diagram of each unique access controlled opening showing location and interconnection of major system components with respect to their placement in the respective door openings.
 - b. Complete (risers, point-to-point) access control system block wiring diagrams.

2. Electrical Coordination: Coordinate with related Division 26 Electrical Sections the voltages and wiring details required at electrically controlled and operated hardware openings.
- D. Keying Schedule: Prepared under the supervision of the Owner, separate schedule detailing final keying instructions for locksets and cylinders in writing. Include keying system explanation, door numbers, key set symbols, hardware set numbers and special instructions. Owner to approve submitted keying schedule prior to the ordering of permanent cylinders.
- E. Operating and Maintenance Manuals: Provide manufacturers operating and maintenance manuals for each item comprising the complete door hardware installation in quantity as required in Division 01, Closeout Submittals. The manual to include the name, address, and contact information of the manufacturers providing the hardware and their nearest service representatives. The final copies delivered after completion of the installation test to include "as built" modifications made during installation, checkout, and acceptance.
- F. Warranties and Maintenance: Special warranties and maintenance agreements specified in this Section.

1.4 QUALITY ASSURANCE

- A. Manufacturers Qualifications: Engage qualified manufacturers with a minimum 5 years of documented experience in producing hardware and equipment similar to that indicated for this Project and that have a proven record of successful in-service performance.
- B. Installer Qualifications: Installers, trained by the primary product manufacturers, with a minimum 3 years documented experience installing both standard and electrified builders hardware similar in material, design, and extent to that indicated for this Project and whose work has resulted in construction with a record of successful in-service performance.
- C. Door Hardware Supplier Qualifications: Experienced commercial door hardware distributors with a minimum 5 years documented experience supplying both mechanical and electromechanical hardware installations comparable in material, design, and extent to that indicated for this Project. Supplier recognized as a factory direct distributor in good standing by the manufacturers of the primary materials with a warehousing facility in Project's vicinity. Supplier to have on staff a certified Architectural Hardware Consultant (AHC) available during the course of the Work to consult with Contractor, Architect, and Owner concerning both standard and electromechanical door hardware and keying.
 1. Scheduling Responsibility: Preparation of door hardware and keying schedules.
- D. Source Limitations: Obtain each type and variety of Door Hardware specified in this Section from a single source, qualified supplier unless otherwise indicated.
 1. Electrified modifications or enhancements made to a source manufacturer's product line by a secondary or third party source will not be accepted.
 2. Provide electromechanical door hardware from the same manufacturer as mechanical door hardware, unless otherwise indicated.

- E. Regulatory Requirements: Comply with NFPA 70, NFPA 80, NFPA 101 and ANSI A117.1 requirements and guidelines as directed in the model building code including, but not limited to, the following:
1. NFPA 70 "National Electrical Code", including electrical components, devices, and accessories listed and labeled as defined in Article 100 by a testing agency acceptable to authorities having jurisdiction, and marked for intended use.
 2. Where indicated to comply with accessibility requirements, comply with Americans with Disabilities Act (ADA), "Accessibility Guidelines for Buildings and Facilities (ADAAG)," ANSI A117.1 as follows:
 - a. Handles, Pulls, Latches, Locks, and other Operating Devices: Shape that is easy to grasp with one hand and does not require tight grasping, tight pinching, or twisting of the wrist.
 - b. Door Closers: Comply with the following maximum opening-force requirements indicated:
 - 1) Interior Hinged Doors: **5 lbf** applied perpendicular to door.
 - 2) Fire Doors: Minimum opening force allowable by authorities having jurisdiction.
 - c. Thresholds: Not more than **1/2 inch** high. Bevel raised thresholds with a slope of not more than 1:2.
 3. NFPA 101: Comply with the following for means of egress doors:
 - a. Latches, Locks, and Exit Devices: Not more than **15 lbf** to release the latch. Locks shall not require the use of a key, tool, or special knowledge for operation.
 - b. Thresholds: Not more than **1/2 inch** high.
 4. Fire-Rated Door Assemblies: Provide door hardware for assemblies complying with NFPA 80 that are listed and labeled by a testing and inspecting agency acceptable to authorities having jurisdiction, for fire ratings indicated, based on testing according to NFPA 252 (neutral pressure at 40" above sill) or UL-10C.
 - a. Test Pressure: Positive pressure labeling.
- F. Each unit to bear third party permanent label demonstrating compliance with the referenced standards.
- G. Keying Conference: Conduct conference to comply with requirements in Division 01 Section "Project Meetings." Keying conference to incorporate the following criteria into the final keying schedule document:
1. Function of building, purpose of each area and degree of security required.
 2. Plans for existing and future key system expansion.
 3. Requirements for key control storage and software.
 4. Installation of permanent keys, cylinder cores and software.
 5. Address and requirements for delivery of keys.

- H. Pre-Submittal Conference: Conduct coordination conference in compliance with requirements in Division 01 Section "Project Meetings" with attendance by representatives of Supplier(s), Installer(s), and Contractor(s) to review proper methods and the procedures for receiving, handling, and installing door hardware.
 - 1. Prior to installation of door hardware, arrange for manufacturers' representatives to hold a project specific training meeting to instruct the installing contractors' personnel on the proper installation and adjustment of their respective products. Product training to be attended by installers of door hardware (including electromechanical hardware) for aluminum, hollow metal and wood doors. Training will include the use of installation manuals, hardware schedules, templates and physical product samples as required.
 - 2. Inspect and discuss electrical roughing-in, power supply connections, and other preparatory work performed by other trades.
 - 3. Review sequence of operation narratives for each unique access controlled opening.
 - 4. Review and finalize construction schedule and verify availability of materials.
 - 5. Review the required inspecting, testing, commissioning, and demonstration procedures
- I. At completion of installation, provide written documentation that components were applied to manufacturer's instructions and recommendations and according to approved schedule.

1.5 DELIVERY, STORAGE, AND HANDLING

- A. Inventory door hardware on receipt and provide secure lock-up and shelving for door hardware delivered to Project site. Do not store electronic access control hardware, software or accessories at Project site without prior authorization.
- B. Tag each item or package separately with identification related to the final Door Hardware Schedule, and include basic installation instructions with each item or package.
- C. Deliver, as applicable, permanent keys, cylinders, cores, access control credentials, software and related accessories directly to Owner via registered mail or overnight package service. Instructions for delivery to the Owner shall be established at the "Keying Conference".

1.6 COORDINATION

- A. Templates: Obtain and distribute to the parties involved templates for doors, frames, and other work specified to be factory prepared for installing standard and electrified hardware. Check Shop Drawings of other work to confirm that adequate provisions are made for locating and installing hardware to comply with indicated requirements.
- B. Door Hardware and Electrical Connections: Coordinate the layout and installation of scheduled electrified door hardware and related access control equipment with required connections to source power junction boxes, low voltage power supplies, detection and monitoring hardware, and fire and detection alarm systems.
- C. Door and Frame Preparation: Related Division 08 Sections (Steel, Aluminum and Wood) doors and corresponding frames are to be prepared, reinforced and pre-wired (if applicable) to receive the installation of the specified electrified, monitoring, signaling and access control system hardware without additional in-field modifications.

1.7 WARRANTY

- A. General Warranty: Reference Division 01, General Requirements. Special warranties specified in this Article shall not deprive Owner of other rights Owner may have under other provisions of the Contract Documents and shall be in addition to, and run concurrent with, other warranties made by Contractor under requirements of the Contract Documents.
- B. Warranty Period: Written warranty, executed by manufacturer(s), agreeing to repair or replace components of standard and electrified door hardware that fails in materials or workmanship within specified warranty period after final acceptance by the Owner. Failures include, but are not limited to, the following:
 - 1. Structural failures including excessive deflection, cracking, or breakage.
 - 2. Faulty operation of the hardware.
 - 3. Deterioration of metals, metal finishes, and other materials beyond normal weathering.
 - 4. Electrical component defects and failures within the systems operation.
- C. Standard Warranty Period: One year from date of Substantial Completion, unless otherwise indicated.
- D. Special Warranty Periods:
 - 1. Seven years for heavy duty cylindrical (bored) locks and latches.
 - 2. Five years for exit hardware.
 - 3. Ten years for heavy duty floor closers.
 - 4. Two years for shallow depth floor closers.
 - 5. Two years for electromechanical door hardware.

1.8 MAINTENANCE SERVICE

- A. Maintenance Tools and Instructions: Furnish a complete set of specialized tools and maintenance instructions as needed for Owner's continued adjustment, maintenance, and removal and replacement of door hardware.
- B. Continuing Service: Beginning at Substantial Completion, and running concurrent with the specified warranty period, provide continuous (6) months full maintenance including repair and replacement of worn or defective components, lubrication, cleaning, and adjusting as required for proper door opening operation. Provide parts and supplies as used in the manufacture and installation of original products.

PART 2 - PRODUCTS

2.1 SCHEDULED DOOR HARDWARE

- A. General: Provide door hardware for each door to comply with requirements in Door Hardware Sets and each referenced section that products are to be supplied under.
 - 1. Designations: Requirements for quantity, item, size, finish or color, grade, function, and other distinctive qualities of each type of door hardware are indicated in the Door

Hardware Sets at the end of Part 3. Products are identified by using door hardware designations, as follows:

- a. Named Manufacturer's Products: Product designation and manufacturer are listed for each door hardware type required for the purpose of establishing requirements. Manufacturers' names are abbreviated in the Door Hardware Schedule.
- B. Substitutions: Requests for substitution and product approval for inclusive mechanical and electromechanical door hardware in compliance with the specifications must be submitted in writing and in accordance with the procedures and time frames outlined in Division 01, Substitution Procedures. Approval of requests is at the discretion of the architect, owner, and their designated consultants.

2.2 HANGING DEVICES

- A. Hinges: ANSI/BHMA A156.1 certified butt hinges with number of hinge knuckles as specified in the Door Hardware Sets.
 1. Quantity: Provide the following hinge quantity, unless otherwise indicated:
 - a. Two Hinges: For doors with heights up to 60 inches.
 - b. Three Hinges: For doors with heights 61 to 90 inches.
 - c. Four Hinges: For doors with heights 91 to 120 inches.
 - d. For doors with heights more than 120 inches, provide 4 hinges, plus 1 hinge for every 30 inches of door height greater than 120 inches.
 2. Hinge Size: Provide the following, unless otherwise indicated, with hinge widths sized for door thickness and clearances required:
 - a. Widths up to 3'0": 4-1/2" standard or heavy weight as specified.
 - b. Sizes from 3'1" to 4'0": 5" standard or heavy weight as specified.
 3. Hinge Weight and Base Material: Unless otherwise indicated, provide the following:
 - a. Exterior Doors: Heavy weight, non-ferrous, ball bearing or oil impregnated bearing hinges unless Hardware Sets indicate standard weight.
 - b. Interior Doors: Standard weight, steel, ball bearing or oil impregnated bearing hinges unless Hardware Sets indicate heavy weight.
 4. Hinge Options: Comply with the following where indicated in the Hardware Sets or on Drawings:
 - a. Non-removable Pins: Provide set screw in hinge barrel that, when tightened into a groove in hinge pin, prevents removal of pin while door is closed; for the following applications:
 - 1) Out-swinging exterior doors.
 - 2) Out-swinging access controlled doors.
 - 3) Out-swinging lockable doors.

5. Acceptable Manufacturers:
 - a. McKinney Products (MK).

2.3 DOOR OPERATING TRIM

- A. Flush Bolts and Surface Bolts: ANSI/BHMA A156.3 and A156.16, Grade 1, certified automatic, self-latching, and manual flush bolts and surface bolts. Manual flush bolts to be furnished with top rod of sufficient length to allow bolt location approximately six feet from the floor. Furnish dust proof strikes for bottom bolts. Surface bolts to be minimum 8" in length and U.L. listed for labeled fire doors and U.L. listed for windstorm components where applicable. Provide related accessories (mounting brackets, strikes, coordinators, etc.) as required for appropriate installation and operation.
 1. Acceptable Manufacturers:
 - a. Rockwood Manufacturing (RO).
- B. Coordinators: ANSI/BHMA A156.3 certified door coordinators consisting of active-leaf, hold-open lever and inactive-leaf release trigger. Coordinators fabricated from steel with nylon-coated strike plates and built-in adjustable safety release.
 1. Acceptable Manufacturers:
 - a. Rockwood Manufacturing (RO).

2.4 MECHANICAL LOCKS AND LATCHING DEVICES

- A. Cylindrical Locksets, Grade 1 (Heavy Duty): ANSI/BHMA A156.2, Series 4000, Grade 1 certified cylindrical (bored) locksets furnished in the functions as specified in the Hardware Sets. Lock chassis fabricated of heavy gauge steel, zinc dichromate plated, with through-bolted application. Furnish with solid cast levers, standard 2 3/4" backset, and 1/2" (3/4" at rated paired openings) throw brass or stainless steel latchbolt. Locks are to be non-handed and fully field reversible.
 1. Acceptable Manufacturers:
 - a. Corbin Russwin Hardware (RU) – CL3300 Series.
- B. Lock Trim Design: As specified in Hardware Sets.

2.5 LOCK AND LATCH STRIKES

- A. Strikes: Provide manufacturer's standard strike with strike box for each latch or lock bolt, with curved lip extended to protect frame, finished to match door hardware set, unless otherwise indicated, and as follows:
 1. Flat-Lip Strikes: For locks with three-piece antifriction latchbolts, as recommended by manufacturer.

2. Extra-Long-Lip Strikes: For locks used on frames with applied wood casing trim.
3. Aluminum-Frame Strike Box: Provide manufacturer's special strike box fabricated for aluminum framing.

B. Standards: Comply with the following:

1. Strikes for Mortise Locks and Latches: BHMA A156.13.
2. Strikes for Bored Locks and Latches: BHMA A156.2.
3. Strikes for Auxiliary Deadlocks: BHMA A156.5.
4. Dustproof Strikes: BHMA A156.16.

2.6 CONVENTIONAL EXIT DEVICES

A. General Requirements: All exit devices specified herein shall meet or exceed the following criteria:

1. At doors not requiring a fire rating, provide devices complying with NFPA 101 and listed and labeled for "Panic Hardware" according to UL305. Provide proper fasteners as required by manufacturer including sex nuts and bolts at openings specified in the Hardware Sets.
2. Where exit devices are required on fire rated doors, provide devices complying with NFPA 80 and with UL labeling indicating "Fire Exit Hardware". Provide devices with the proper fasteners for installation as tested and listed by UL. Consult manufacturer's catalog and template book for specific requirements.
 - a. Fire Exit Removable Mullions: Provide keyed removable mullions for use with fire exit devices complying with NFPA 80 that are listed and labeled by a testing and inspecting agency acceptable to authorities having jurisdiction, for fire and panic protection, based on testing according to UL 305 and NFPA 252. Mullions to be used only with exit devices for which they have been tested.
3. Except on fire rated doors, provide exit devices with hex key dogging device to hold the pushbar and latch in a retracted position. Provide optional keyed cylinder dogging on devices where specified in Hardware Sets.
4. Flush End Caps: Provide heavy weight impact resistant flush end caps made of architectural metal in the same finish as the devices as in the Hardware Sets. Plastic end caps will not be acceptable.
5. Lever Operating Trim: Where exit devices require lever trim, furnish manufacturer's heavy duty trim with cold forged escutcheons, beveled edges, and four threaded studs for thru-bolts.
 - a. Lock Trim Design: As indicated in Hardware Sets, provide finishes and designs to match that of the specified locksets. Provided free-wheeling type trim where indicated.
 - b. Where function of exit device requires a cylinder, provide an interchangeable core type keyed cylinder (Rim or Mortise) as specified in Hardware Sets.

6. Vertical Rod Exit Devices: Provide and install interior surface and concealed vertical rod exit devices as Less Bottom Rod (LBR) unless otherwise indicated.
 7. Narrow Stile Applications: At doors constructed with narrow stiles, or as specified in Hardware Sets, provide devices designed for maximum 2" wide stiles.
 8. Dummy Push Bar: Nonfunctioning push bar matching functional push bar.
 9. Rail Sizing: Provide exit device rails factory sized for proper door width application.
 10. Through Bolt Installation: For exit devices and trim as indicated in Door Hardware Sets.
- B. Conventional Push Rail Exit Devices (Heavy Duty): ANSI/BHMA A156.3, Grade 1 certified panic and fire exit hardware devices furnished in the functions specified in the Hardware Sets. Mounting rails to be formed from smooth stainless steel, brass or bronze architectural materials no less than 0.072" thick, with push rails a minimum of 0.062" thickness. Painted or aluminum metal rails are not acceptable. Exit device latch to be investment cast stainless steel, pullman type, with deadlock feature.
1. Acceptable Manufacturers:
 - a. Corbin Russwin Hardware (RU) - ED4000 / ED5000 Series.

2.7 DOOR CLOSERS

- A. All door closers specified herein shall meet or exceed the following criteria:
1. General: Door closers to be from one manufacturer, matching in design and style, with the same type door preparations and templates regardless of application or spring size. Closers to be non-handed with full sized covers including installation and adjusting information on inside of cover.
 2. Standards: Closers to comply with UL-10C and UBC 7-2 for Positive Pressure Fire Test and be U.L. listed for use of fire rated doors.
 3. Size of Units: Comply with manufacturer's written recommendations for sizing of door closers depending on size of door, exposure to weather, and anticipated frequency of use. Where closers are indicated for doors required to be accessible to the physically handicapped, provide units complying with ANSI ICC/A117.1.
 4. Closer Arms: Provide heavy duty, forged steel closer arms unless otherwise indicated in Hardware Sets.
 - a. Where closers are indicated to have mechanical dead-stop, provide heavy duty arms and brackets with an integral positive stop.
 - b. Where closers are indicated to have mechanical hold open, provide heavy duty units with an additional built-in mechanical holder assembly designed to hold open against normal wind and traffic conditions. Holder to be manually selectable to on-off position.

- c. Where closers are indicated to have a cushion-type stop, provide heavy duty arms and brackets with spring stop mechanism to cushion door when opened to maximum degree.
 - d. Closers shall not be installed on exterior or corridor side of doors; where possible install closers on door for optimum aesthetics. Provide drop plates or other accessories as required for proper mounting.
 5. Closer Accessories: Provide door closer accessories including custom templates, special mounting brackets, spacers and drop plates, and through-bolt or security type fasteners as specified in the door Hardware Sets.
- B. Door Closers, Surface Mounted (Commercial Duty): ANSI/BHMA 156.4, Grade 1 certified surface mounted, institutional grade door closers with complete spring power adjustment, sizes 1 thru 6; and fully operational adjustable according to door size, frequency of use, and opening force. Closers to be rack and pinion type, one piece cast iron or aluminum alloy body construction, with adjustable backcheck, closing sweep, and latch speed control valves. Provide non-handed units standard.
 1. Acceptable Manufacturers:
 - a. Corbin Russwin Hardware (RU) – DC8000 Series.

2.8 ARCHITECTURAL TRIM

A. Door Protective Trim

1. General: Door protective trim units to be of type and design as specified below or in the Hardware Sets.
2. Size: Fabricate protection plates (kick, armor, or mop) not more than 2" less than door width (LDW) on stop side of single doors and 1" LDW on stop side of pairs of doors, and not more than 1" less than door width on pull side. Coordinate and provide proper width and height as required where conflicting hardware dictates. Height to be as specified in the Hardware Sets.
3. Metal Protection Plates: ANSI/BHMA A156.6 certified metal protection plates (kick, armor, or mop), beveled on four edges (B4E), fabricated from the following.
 - a. Stainless Steel: .050-inch thick, with countersunk screw holes (CSK).
 - b. Brass or Bronze: .050-inch thick, with countersunk screw holes (CSK).
 - c. Laminate Plastic or Acrylic: 1/8-inch thick, with countersunk screw holes (CSK).
4. Fasteners: Provide manufacturer's designated fastener type as specified in the Hardware Sets.
5. Metal Door Edging: Door protection edging fabricated from a minimum .050-inch thick metal sheet, formed into an angle or "U" cap shapes, surface or mortised mounted onto edge of door. Provide appropriate leg overlap to account for protection plates as required. Height to be as specified in the Hardware Sets.

6. Acceptable Manufacturers:
 - a. Rockwood Manufacturing (RO).

2.9 DOOR STOPS AND HOLDERS

- A. General: Door stops and holders to be of type and design as specified below or in the Hardware Sets.
- B. Door Stops and Bumpers: ANSI/BHMA A156.16, Grade 1 certified door stops and wall bumpers. Provide wall bumpers, either convex or concave types with anchorage as indicated, unless floor or other types of door stops are specified in Hardware Sets. Do not mount floor stops where they will impede traffic. Where floor or wall bumpers are not appropriate, provide overhead type stops and holders.
 1. Acceptable Manufacturers:
 - a. Rockwood Manufacturing (RO).

2.10 ARCHITECTURAL SEALS

- A. General: Thresholds, weatherstripping, and gasket seals to be of type and design as specified below or in the Hardware Sets. Provide continuous weatherstrip gasketing on exterior doors and provide smoke, light, or sound gasketing on interior doors where indicated. At exterior applications provide non-corrosive fasteners and elsewhere where indicated.
- B. Smoke Labeled Gasketing: Assemblies complying with NFPA 105 that are listed and labeled by a testing and inspecting agency acceptable to authorities having jurisdiction, for smoke control ratings indicated, based on testing according to UL 1784.
 1. Provide smoke labeled perimeter gasketing at all smoke labeled openings.
- C. Fire Labeled Gasketing: Assemblies complying with NFPA 80 that are listed and labeled by a testing and inspecting agency acceptable to authorities having jurisdiction, for fire ratings indicated, based on testing according to UL-10C.
 1. Provide intumescent seals as indicated to meet UL10C Standard for Positive Pressure Fire Tests of Door Assemblies, and UBC 7-2, Fire Tests of Door Assemblies.
- D. Sound-Rated Gasketing: Assemblies that are listed and labeled by a testing and inspecting agency, for sound ratings indicated, based on testing according to ASTM E 1408.
- E. Replaceable Seal Strips: Provide only those units where resilient or flexible seal strips are easily replaceable and readily available from stocks maintained by manufacturer.
- F. Acceptable Manufacturers:
 1. Pemko Manufacturing (PE).

2.11 FABRICATION

- A. Fasteners: Provide door hardware manufactured to comply with published templates generally prepared for machine, wood, and sheet metal screws. Provide screws according to manufacturers recognized installation standards for application intended.

2.12 FINISHES

- A. Standard: Designations used in the Hardware Sets and elsewhere indicate hardware finishes complying with ANSI/BHMA A156.18, including coordination with traditional U.S. finishes indicated by certain manufacturers for their products.
- B. Provide quality of finish, including thickness of plating or coating (if any), composition, hardness, and other qualities complying with manufacturer's standards, but in no case less than specified by referenced standards for the applicable units of hardware.
- C. Protect mechanical finishes on exposed surfaces from damage by applying a strippable, temporary protective covering before shipping.

PART 3 - EXECUTION

3.1 EXAMINATION

- A. Examine scheduled openings, with Installer present, for compliance with requirements for installation tolerances, labeled fire door assembly construction, wall and floor construction, and other conditions affecting performance.
- B. Notify architect of any discrepancies or conflicts between the door schedule, door types, drawings and scheduled hardware. Proceed only after such discrepancies or conflicts have been resolved in writing.

3.2 PREPARATION

- A. Hollow Metal Doors and Frames: Comply with ANSI/DHI A115 series.
- B. Wood Doors: Comply with ANSI/DHI A115-W series.

3.3 INSTALLATION

- A. Install each item of mechanical and electromechanical hardware and access control equipment to comply with manufacturer's written instructions and according to specifications.
 - 1. Installers are to be trained and certified by the manufacturer on the proper installation and adjustment of fire, life safety, and security products including: hanging devices; locking devices; closing devices; and seals.

- B. **Mounting Heights:** Mount door hardware units at heights indicated in following applicable publications, unless specifically indicated or required to comply with governing regulations:
 - 1. Standard Steel Doors and Frames: DHI's "Recommended Locations for Architectural Hardware for Standard Steel Doors and Frames."
 - 2. Wood Doors: DHI WDHS.3, "Recommended Locations for Architectural Hardware for Wood Flush Doors."
 - 3. Where indicated to comply with accessibility requirements, comply with ANSI A117.1 "Accessibility Guidelines for Buildings and Facilities."
 - 4. Provide blocking in drywall partitions where wall stops or other wall mounted hardware is located.
- C. **Retrofitting:** Install door hardware to comply with manufacturer's published templates and written instructions. Where cutting and fitting are required to install door hardware onto or into surfaces that are later to be painted or finished in another way, coordinate removal, storage, and reinstallation of surface protective trim units with finishing work specified in Division 9 Sections. Do not install surface-mounted items until finishes have been completed on substrates involved.
- D. **Thresholds:** Set thresholds for exterior and acoustical doors in full bed of sealant complying with requirements specified in Division 7 Section "Joint Sealants."
- E. **Storage:** Provide a secure lock up for hardware delivered to the project but not yet installed. Control the handling and installation of hardware items so that the completion of the work will not be delayed by hardware losses before and after installation.

3.4 FIELD QUALITY CONTROL

- A. **Field Inspection:** Supplier will perform a final inspection of installed door hardware and state in report whether work complies with or deviates from requirements, including whether door hardware is properly installed, operating and adjusted.

3.5 ADJUSTING

- A. **Initial Adjustment:** Adjust and check each operating item of door hardware and each door to ensure proper operation or function of every unit. Replace units that cannot be adjusted to operate as intended. Adjust door control devices to compensate for final operation of heating and ventilating equipment and to comply with referenced accessibility requirements.

3.6 CLEANING AND PROTECTION

- A. Protect all hardware stored on construction site in a covered and dry place. Protect exposed hardware installed on doors during the construction phase. Install any and all hardware at the latest possible time frame.
- B. Clean adjacent surfaces soiled by door hardware installation.

- C. Clean operating items as necessary to restore proper finish, and provide final protection and maintain conditions that ensure door hardware is without damage or deterioration at time of owner occupancy.

3.7 DEMONSTRATION

- A. Instruct Owner's maintenance personnel to adjust, operate, and maintain mechanical and electromechanical door hardware.

3.8 DOOR HARDWARE SCHEDULE

- A. The hardware sets represent the design intent and direction of the owner and architect. They are a guideline only and should not be considered a detailed hardware schedule. Discrepancies, conflicting hardware and missing items should be brought to the attention of the architect with corrections made prior to the bidding process. Omitted items not included in a hardware set should be scheduled with the appropriate additional hardware required for proper application and functionality.

Hardware Schedule

Set: 1.0

Doors: A101

1 Continuous Hinge	780-112HD	US32D
1 Exit Device (rim, classroom)	ED5200 N955	626
1 Cylinder	3000	626
1 Closer (surface)	DC8210	689
1 Kickplate	K1050 10" X 2"LDW 3BE CSK	US32D
1 Wall Stop	409	US32D
1 Gasketing	303 AV	
1 Sweep	315 CN	

Set: 2.0

Doors: A102A, A102B, A103

1 Continuous Hinge	780-112HD	US32D
1 Cylindrical Lock (classroom)	CL3355 NZD	626
1 Closer (surface)	DC8210	689
1 Kickplate	K1050 10" X 2"LDW 3BE CSK	US32D
1 Wall Stop	409	US32D
1 Gasketing	S773D	

Set: 3.0

Doors: A105

3 Hinge	TA2714 4-1/2" x 4-1/2"	US26D
1 Cylindrical Lock (Entrance)	CL3351 NZD	626
1 Closer (surface)	DC8210	689
Balance of hardware by Door Supplier		

Set: 4.0

Doors: A106

3 Hinge	TA2714 4-1/2" x 4-1/2"	US26D
1 Cylindrical Lock (privacy)	CL3320 NZD	626
1 Closer (surface)	DC6210	689
1 Kickplate	K1050 10" X 2"LDW 3BE CSK	US32D
1 Wall Stop	409	US32D
1 Gasketing	S773D	

SECTION 08 80 00 – GLAZING**PART 1 - GENERAL****1.1 SUMMARY**

- A. Furnish labor, materials, tools, equipment, and services for Interior Glass and Glazing in accordance with provisions of Contract Documents.
- B. Completely coordinate with work of other trades.
- C. Related Sections:
 - 1. Section 08 41 00 "Aluminum Entrances and Storefronts."
 - 2. Section 08 44 13 "Glazed Aluminum Curtain Walls."

1.2 QUALITY ASSURANCE

- A. Glass Standards:
 - 1. ANSI Z97.1.
 - 2. CPSC 16 CFR 1201.
 - 3. GANA Glazing Manual.
- B. Flat Glass ASTM C1036.
 - 1. Float glass: Type I, Quality q3 and Class 1 unless otherwise indicated.
 - 2. Figured glass: Type II, Quality q7, Form 3 and Class 1, Finish f1 and Pattern p2 unless otherwise indicated.
 - 3. Mirror glass and one-way vision glass: Type I, Quality q1 or q2, Class 1 and coated for purpose.
- C. Flat Glass, Heat Treated, Coated and Uncoated, ASTM C1048.
 - 1. Heat strengthened glass: Kind HS, Type I, Quality q3, Class 1 and Condition A unless otherwise indicated.
 - 2. Tempered glass: Kind FT, Type I, Quality q3, Class 1 and Condition A unless otherwise indicated.
- D. Mirror Glass:
 - 1. ASTM C1503;
 - 2. Quality: Mirror select.
 - 3. F.S.DD-M-00411B (1).
- E. Fire-Rated Assemblies:
 - 1. General:
 - a. Where glazing products are used in fire-rated assemblies, comply with requirements of specific assembly specified in other sections of these Specifications.
 - b. Underwriters Laboratories, Inc. (UL):
 - 1) UL 9 – Fire Tests of Window Assemblies.
 - 2) UL 10B – Fire Tests of Door Assemblies.
 - 3) UL 10C – Positive Pressure Fire Tests of Door Assemblies.
 - c. Fire Protective Rated Glass: Each lite shall bear permanent, non-removable label of UL certifying it for use in tested and rated fire protective assemblies.
 - 2. Door Assemblies:
 - a. Complying with NFPA 80 and listed and labeled by a testing and inspecting agency acceptable to authorities having jurisdiction, for fire ratings indicated, based on testing according to NFPA 252.

- b. Positive Pressure Compliance: UL 10C.
- c. Fire Protective Glazing Products for Door Assemblies: Products identical to those tested per UL 10B, labeled and listed by UL.
- 3. Window Assemblies:
 - a. Complying with NFPA 80 that are listed and labeled by a testing and inspecting agency acceptable to authorities having jurisdiction, for fire ratings indicated, based on testing according to NFPA 257.
 - b. Positive Pressure Compliance: UL 10C.
- F. Laminated Glass:
 - 1. ASTM C1172 Standard Specification for Laminated Architectural Flat Glass.
 - 2. Laminated Glass Design Guide, by the Glass Association of North America (GANA).
- G. Glazing Standards:
 - 1. Glazing Manual, by the Glass Association of North America (GANA).

1.3 SUBMITTALS

- A. Samples:
 - 1. Provide one (1) 12 IN x 12 IN example of each specified type of glass.
- B. Contract Closeout Information:
 - 1. Warranties.
- C. Smoke baffle system:
 - 1. Shop drawing details, plans and elevations showing supports to building structure, interface at ceiling, blocking, baffle shoe, cap rail, grommet, cladding, sealant/adhesive, and glass.
 - 2. Product data.
 - 3. Standard warranty.
 - 4. Installation Instructions

1.4 WARRANTY

- A. Written warranty signed by manufacturer or fabricator.
- B. Laminated Glass:
 - 1. Five (5) years against deterioration including edge separation, delamination that materially obstructs vision through glass, and blemishes exceeding those allowed by referenced laminated-glass standard.
- C. Fire-rated Ceramics:
 - 1. Five (5) year manufacturer's standard warranty.

PART 2 - PRODUCTS

2.1 ACCEPTABLE MANUFACTURERS

- A. Glass Products:
 - 1. Base:
 - a. AGC Industries.
 - 2. Optional:
 - a. Guardian Industries.
 - b. Pilkington.
 - c. PPG Industries.
 - d. Saint-Gobain.

- B. Fire-rated Glass Ceramic:
 - 1. Base:
 - a. Technical Glass Products.
 - 2. Optional:
 - a. Saffi First.
 - b. Pilkington.
 - c. Saint-Gobain.
- C. Radiation-resistant Glass. Based on, but not limited to the following:
 - 1. Base:
 - a. Ray-Bar Engineering Corp.
 - 2. Optional:
 - a. Nelco.
 - b. Corning Inc.
 - c. Schott North America, Inc.
 - d. Radiation Protection Products (RPP).

2.2 MATERIALS

- A. Glass Materials:
 - 1. Comply with indicated standards.
 - 2. See Glass Types Schedule for listing of types.
 - 3. Materials specified in Glass Types Schedules are minimum acceptable products.
 - 4. Single manufacturer produced individual glass types used in fabrication of insulating units.
 - 5. Manufacturer or fabricator determine if materials should be heat strengthened or fully tempered at non-hazardous locations that do not require safety glazing and provide accordingly.
- B. Glazing Compounds:
 - 1. Nonsag, nonstain type.
 - 2. Pigmented to match frame units not requiring painting.
 - 3. Compatible with adjacent surfaces.
 - 4. For use in setting glass: Neutral-cure Silicone sealant.
 - 5. Sealants:
 - a. Sealants shall have a VOC content no greater than 250 g/L.
 - b. Sealants shall contain no carcinogen or reproductive toxicant components present at more than 1% of total mass of the product as defined in the California Office of Environmental Health Hazard Assessment's (OEHHA) list entitled "Chemicals Known to the State to Cause Cancer" or the Reproductive Toxicity, Safe Drinking Water and Toxic Enforcement Act of 1986 (Proposition 65).
 - 6. Sealant tape:
 - a. Butyl rubber sealant tape or ribbon having a continuous neoprene shim.
 - 7. Gaskets:
 - a. Polyvinyl chloride or neoprene.
 - b. Extruded, flexible, of profile and hardness required to receive glass and provide a watertight installation.
- C. Installation Setting Blocks and Spacers:
 - 1. Neoprene, compatible with sealants used.
 - 2. Setting blocks: 80-90 durometer.
 - 3. Spacers: 40-50 durometer.

4. Compressible filler stock: Closed cell jacketed rod stock of synthetic rubber or plastic foam.
5. Shims, clips, springs, angles, beads, attachment screws and other miscellaneous items: As indicated or required.

2.3 GLASS TYPES SCHEDULE

- A. Refer to Interior Glass Types Schedule and Interior Finish Schedule for basic description of Mark Numbers indicated on Drawing.
- B. Refer to Drawings for depiction of unit sizes and locations.
- C. Upgrade basic type conditions in accordance with following rules:
 1. Heat treatment upgrade based on physical size of unit:
 - a. Heat strengthened or fully tempered units between 55 and 70 SF.
 - b. Fully temper units exceeding 70 SF.
 - c. Strengthen annealed glass where units exceed length or width limitations or both as recommended by glass manufacturer.
 2. Heat treatment upgrade based on locations which are potentially hazardous to occupants:
 - a. Upgrade units to fully tempered, Kind FT, glass as required by any one of following:
 - 1) When required by local Codes.
 - 2) When specifically indicated on Drawings.
 - 3) Locations requiring Safety Glass, Kind FT, by 16 CFR 1201 and ANSI Z97.1:
 - a) Units installed in doors, sash, transom or other operable units.
 - b) Units where any part of unit is within 18 IN, measured vertically, above a floor line, sidewalk, paver, or other walking surface located within 3 FT of the glass unit, measured horizontally.
 - 4) Units in sidelights and other units located adjacent to and within 48 IN of either jamb of door or other operable units; this includes adjacent lites that are in perpendicular plane to door.
 3. Other conditions requiring heat treatment upgrades:
 - a. Units which will be exposed to irregular sun or shade combinations or both shall be Kind HS or better.
 - b. Where glass manufacturer recommends heat treatment coatings or tints specified.
 - c. Where required to resist lateral loads.

2.4 INTERIOR GLASS TYPES

A. Annealed:

1. Clear float, 6mm (1/4 IN) thick, UNO.

B. Tempered:

1. Clear, fully-tempered tongue-less float, 12 mm (1/2 IN) thick at all glass entrance and aluminum storefront systems, 6mm (1/4 IN) thick elsewhere, unless noted otherwise.

C. Laminated Fire and Safety Glass, 8mm:

1. Laminated, wireless, UL labeled for assembly indicated.
2. Impact-Safety Rated per ANSI Z97.1 and CPSC 16CFR1201.
3. Thickness: 8mm (5/16 IN), laminated.
4. Surface: Polished.
5. Base Product: FireLite Plus by Technical Glass Products.

D. Mirror Glass:

1. Color: Clear.
2. Thickness: 6mm (1/4 IN).
3. Unit Length and Width: As indicated on drawings.
4. Tempered.

E. Radiation-Resistant Glazing:

1. Composition: Lead-barium, polished float glass containing not less than 60 percent heavy metal oxides, including not less than 48 percent lead oxide by weight.
2. Color: Clear.
3. Provide glass units of sufficient thickness to provide same radiation shielding as adjacent wall areas. Provide single or multiple plies as necessary.

F. Laminated, Heat-Strengthened Glass:

1. Laminated safety glass complying with ANSI Z97.1 and CPSC 16 CFR 1201, consisting of 2 sheets of heat strengthened float glass ASTM C1036, and 60 mil interlayer.

PART 3 - EXECUTION**3.1 INSPECTION**

- A. Examine framing or glazing channel surfaces, backing, stop design, and conditions under which glazing is to be installed.

3.2 INSTALLATION

- A. Do not install glass with edge damage.
- B. Contractor is responsible for correct glass size for each opening, within tolerances and dimensions established.
- C. Comply with recommendations of manufacturers, except where more stringent requirements are indicated.
- D. Comply with GANA Glazing Manual.
- E. Install sealants as recommended by sealant manufacturer.
- F. Install setting blocks in adhesive or sealant.
- G. Provide spacers inside and out, of proper size and spacing, for glass size, except where gaskets are used for glazing.
- H. Minimum Bite:
 1. Monolithic, 6mm (1/4 IN) glass: 3/8 IN minimum bite.
 2. For other sizes: Refer to Table C of AAMA's Aluminum Curtain Wall Design Manual, Volume 6, Glass and Glazing.
- I. Sealant Depth: Equal to sealant width.
- J. Prevent sealant exudation from glazing channels.
 1. Leave void at heel or install filler at jambs and head.
 2. Do not leave void or install filler at sill.
- K. Miter cut and bond gasket ends together at corners.
- L. Immediately after installation, attach crossed streamers to framing held away from glass.
- M. Do not apply anything to surfaces of glass.

- N. Install spandrel units from exterior of building.
- O. Installation of Mirrors:
 - 1. Mastic Attachment: Install mirrors with mirror adhesive applied to back of mirror and pressed against substrate as recommended by mirror supplier.
- P. Remove and replace damaged glass.
- Q. Installation smoke baffle systems:
 - 1. Install in accordance with approved shop drawings.
 - 2. Follow manufacturers installation instructions.

3.3 CLEANING AND PROTECTION

- A. Wash and polish glass on both faces not more than 7 days prior to final completion of work in each area.
- B. Comply with glass manufacturer's recommendations and GANA 01-0300.

END OF SECTION

SECTION 09 2216 - NON-STRUCTURAL METAL FRAMING

PART 1 - GENERAL

1.1 RELATED DOCUMENTS

- A. Drawings and general provisions of the Contract, including General and Supplementary Conditions and Division 01 Specification Sections, apply to this Section.

1.2 SUMMARY

A. Section Includes:

1. Non-load-bearing steel framing systems for interior partitions.
2. Suspension systems for interior ceilings and soffits.
3. Grid suspension systems for gypsum board ceilings.

B. Related Requirements:

1. Section 05 4000 "Cold-Formed Metal Framing" for exterior and interior load-bearing and exterior non-load-bearing wall studs; floor joists; and roof rafters and ceiling joists.

1.3 ACTION SUBMITTALS

- A. Product Data: For each type of product.

1.4 INFORMATIONAL SUBMITTALS

- A. Product Certificates: For each type of code-compliance certification for studs and tracks.
- B. Evaluation Reports: For high-strength steel studs and tracks, firestop tracks, post-installed anchors and power-actuated fasteners, from ICC-ES or other qualified testing agency acceptable to authorities having jurisdiction.

1.5 QUALITY ASSURANCE

- A. Code-Compliance Certification of Studs and Tracks: Provide documentation that framing members are certified according to the product-certification program of the Steel Stud Manufacturers Association.

PART 2 - PRODUCTS

2.1 PERFORMANCE REQUIREMENTS

- A. Fire-Test-Response Characteristics: For fire-resistance-rated assemblies that incorporate non-load-bearing steel framing, provide materials and construction identical to those tested in assembly indicated, according to ASTM E119 by an independent testing agency.
- B. STC-Rated Assemblies: For STC-rated assemblies, provide materials and construction identical to those tested in assembly indicated on Drawings, according to ASTM E90 and classified according to ASTM E413 by an independent testing agency.
- C. Horizontal Deflection: For composite and non-composite wall assemblies, limited to 1/360 of the wall height based on horizontal loading of 10 lbf/sq. ft..

2.2 FRAMING SYSTEMS

- A. Framing Members, General: Comply with ASTM C754 for conditions indicated.
 - 1. Steel Sheet Components: Comply with ASTM C645 requirements for steel unless otherwise indicated.
 - 2. Protective Coating: ASTM A653/A653M, G40, hot-dip galvanized unless otherwise indicated.
- B. Studs and Tracks: ASTM C645.
 - 1. Steel Studs and Tracks:
 - a. Manufacturers: Subject to compliance with requirements, available manufacturers offering products that may be incorporated into the Work include, but are not limited to the following:
 - 1) CEMCO; California Expanded Metal Products Co.
 - 2) ClarkDietrich.
 - 3) Custom Stud.
 - 4) Jaimes Industries.
 - 5) MarinoWARE.
 - 6) MBA Building Supplies.
 - 7) MRI Steel Framing, LLC.
 - 8) Phillips Manufacturing Co.
 - 9) SCAFCO Steel Stud Company.
 - 10) Steel Construction Systems.
 - 11) Telling Industries.
 - 12) The Steel Network, Inc.
 - b. Minimum Base-Steel Thickness: As indicated on Drawings.
 - c. Depth: As indicated on Drawings.
- C. Slip-Type Head Joints: Where indicated, provide the following:

1. Clip System: Clips designed for use in head-of-wall deflection conditions that provide a positive attachment of studs to tracks while allowing 2-inch minimum vertical movement.
 - a. Manufacturers: Subject to compliance with requirements, available manufacturers offering products that may be incorporated into the Work include, but are not limited to the following:
 - 1) CEMCO; California Expanded Metal Products Co.
 - 2) ClarkDietrich.
 - 3) Fire Trak Corp.
 - 4) MarinoWARE.
 - 5) SCAFCO Steel Stud Company.
 - 6) Steel Construction Systems.
 - 7) Super Stud Building Products Inc.
 - 8) The Steel Network, Inc.
 2. Single Long-Leg Track System: ASTM C645 top track with 2-inch-deep flanges in thickness not less than indicated for studs, installed with studs friction fit into top track and with continuous bridging located within 12 inches of the top of studs to provide lateral bracing.
 3. Double-Track System: ASTM C645 top outer tracks, inside track with 2-inch-deep flanges in thickness not less than indicated for studs and fastened to studs, and outer track sized to friction-fit over inner track.
 4. Deflection Track: Steel sheet top track manufactured to prevent cracking of finishes applied to interior partition framing resulting from deflection of structure above; in thickness not less than indicated for studs and in width to accommodate depth of studs.
 - a. Manufacturers: Subject to compliance with requirements, available manufacturers offering products that may be incorporated into the Work include, but are not limited to the following:
 - 1) CEMCO; California Expanded Metal Products Co.
 - 2) ClarkDietrich.
 - 3) MarinoWARE.
 - 4) MBA Building Supplies.
 - 5) Metal-Lite.
 - 6) Perfect Wall, Inc.
 - 7) SCAFCO Steel Stud Company.
 - 8) Steel Construction Systems.
 - 9) Telling Industries.
 - 10) The Steel Network, Inc.
- D. Firestop Tracks: Top track manufactured to allow partition heads to expand and contract with movement of structure while maintaining continuity of fire-resistance-rated assembly indicated; in thickness not less than indicated for studs and in width to accommodate depth of studs.
1. Manufacturers: Subject to compliance with requirements, available manufacturers offering products that may be incorporated into the Work include, but are not limited to the following:

- a. CEMCO; California Expanded Metal Products Co.
 - b. ClarkDietrich.
 - c. Fire Trak Corp.
 - d. MarinoWARE.
 - e. Metal-Lite.
 - f. Perfect Wall, Inc.
 - g. SCAFCO Steel Stud Company.
 - h. Steel Construction Systems.
 - i. The Steel Network, Inc.
- E. Flat Strap and Backing Plate: Steel sheet for blocking and bracing in length and width indicated.
1. Manufacturers: Subject to compliance with requirements, available manufacturers offering products that may be incorporated into the Work include, but are not limited to the following:
 - a. ClarkDietrich.
 - b. MarinoWARE.
 - c. MBA Building Supplies.
 - d. MRI Steel Framing, LLC.
 - e. SCAFCO Steel Stud Company.
 - f. Steel Construction Systems.
 2. Minimum Base-Steel Thickness: As indicated on Drawings.
- F. Cold-Rolled Channel Bridging: Steel, 0.0538-inch minimum base-steel thickness, with minimum 1/2-inch-wide flanges.
1. Manufacturers: Subject to compliance with requirements, available manufacturers offering products that may be incorporated into the Work include, but are not limited to the following:
 - a. ClarkDietrich.
 - b. MarinoWARE.
 - c. MBA Building Supplies.
 - d. MRI Steel Framing, LLC.
 - e. SCAFCO Steel Stud Company.
 - f. Steel Construction Systems.
 2. Depth: 1-1/2 inches.
 3. Clip Angle: Not less than 1-1/2 by 1-1/2 inches, 0.068-inch-thick, galvanized steel.
- G. Hat-Shaped, Rigid Furring Channels: ASTM C645.
1. Manufacturers: Subject to compliance with requirements, available manufacturers offering products that may be incorporated into the Work include, but are not limited to the following:
 - a. ClarkDietrich.
 - b. Jaimes Industries.
 - c. MarinoWARE.
 - d. MBA Building Supplies.

- e. MRI Steel Framing, LLC.
 - f. SCAFCO Steel Stud Company.
 - g. Steel Construction Systems.
 2. Minimum Base-Steel Thickness: As indicated on Drawings.
 3. Depth: As indicated on Drawings.
- H. Resilient Furring Channels: 1/2-inch-deep, steel sheet members designed to reduce sound transmission.
 1. Manufacturers: Subject to compliance with requirements, available manufacturers offering products that may be incorporated into the Work include, but are not limited to the following:
 - a. ClarkDietrich.
 - b. MarinoWARE.
 - c. MBA Building Supplies.
 - d. MRI Steel Framing, LLC.
 - e. SCAFCO Steel Stud Company.
 - f. Steel Construction Systems.
 2. Configuration: Asymmetrical or hat shaped.
- I. Cold-Rolled Furring Channels: 0.053-inch uncoated-steel thickness, with minimum 1/2-inch-wide flanges.
 1. Depth: As indicated on Drawings.
 2. Furring Brackets: Adjustable, corrugated-edge-type steel sheet with minimum uncoated-steel thickness of 0.0329 inch.
 3. Tie Wire: ASTM A641/A641M, Class 1 zinc coating, soft temper, 0.062-inch-diameter wire, or double strand of 0.048-inch-diameter wire.
- J. Z-Shaped Furring: With slotted or nonslotted web, face flange of 1-1/4 inches, wall attachment flange of 7/8 inch, minimum uncoated-steel thickness of 0.0179 inch, and depth required to fit insulation thickness indicated.
 1. Manufacturers: Subject to compliance with requirements, available manufacturers offering products that may be incorporated into the Work include, but are not limited to the following:
 - a. ClarkDietrich.
 - b. MarinoWARE.
 - c. MBA Building Supplies.
 - d. MRI Steel Framing, LLC.
 - e. SCAFCO Steel Stud Company.
 - f. Steel Construction Systems.

2.3 SUSPENSION SYSTEMS

- A. Tie Wire: ASTM A641/A641M, Class 1 zinc coating, soft temper, 0.062-inch-diameter wire, or double strand of 0.048-inch-diameter wire.
- B. Hanger Attachments to Concrete:

1. Post-Installed Anchors: Fastener systems with an evaluation report acceptable to authorities having jurisdiction, based on ICC-ES AC01 as appropriate for the substrate.
 - a. Uses: Securing hangers to structure.
 - b. Type: Torque-controlled, expansion anchor.
 - c. Material for Interior Locations: Carbon-steel components zinc-plated to comply with ASTM B633 or ASTM F1941, Class Fe/Zn 5, unless otherwise indicated.
 - d. Material for Exterior or Interior Locations and Where Stainless Steel Is Indicated: Alloy Group 1 stainless-steel bolts, ASTM F593, and nuts, ASTM F594.
 2. Power-Actuated Anchors: Fastener systems with an evaluation report acceptable to authorities having jurisdiction, based on ICC-ES AC70.
- C. Wire Hangers: ASTM A641/A641M, Class 1 zinc coating, soft temper, 0.16 inch in diameter.
- D. Flat Hangers: Steel sheet, 1 by 3/16 inch by length indicated.
- E. Carrying Channels (Main Runners): Cold-rolled, commercial-steel sheet with a base-steel thickness of 0.0538 inch and minimum 1/2-inch-wide flanges.
1. Depth: As indicated on Drawings.
- F. Furring Channels (Furring Members):
1. Cold-Rolled Channels: 0.0538-inch uncoated-steel thickness, with minimum 1/2-inch-wide flanges, 3/4 inch deep.
 2. Steel Studs and Tracks: ASTM C645.
 - a. Minimum Base-Steel Thickness: As indicated on Drawings.
 - b. Depth: As indicated on Drawings.
 3. Hat-Shaped, Rigid Furring Channels: ASTM C645, 7/8 inch deep.
 - a. Minimum Base-Steel Thickness: As indicated on Drawings.
 4. Resilient Furring Channels: 1/2-inch-deep members designed to reduce sound transmission.
 - a. Configuration: Asymmetrical or hat shaped.
- G. Grid Suspension System for Gypsum Board Ceilings: ASTM C645, direct-hung system composed of main beams and cross-furring members that interlock.
1. Manufacturers: Subject to compliance with requirements, available manufacturers offering products that may be incorporated into the Work include, but are not limited to the following:
 - a. Armstrong World Industries, Inc.
 - b. Rockfon (Rockwool International).
 - c. USG Corporation.

2.4 AUXILIARY MATERIALS

- A. General: Provide auxiliary materials that comply with referenced installation standards.
 - 1. Fasteners for Steel Framing: Of type, material, size, corrosion resistance, holding power, and other properties required to fasten steel members to substrates.
- B. Isolation Strip at Exterior Walls: Provide one of the following:
 - 1. Asphalt-Saturated Organic Felt: ASTM D226/D226M, Type I (No. 15 asphalt felt), nonperforated.
 - 2. Foam Gasket: Adhesive-backed, closed-cell vinyl foam strips that allow fastener penetration without foam displacement, 1/8 inch thick, in width to suit steel stud size.

PART 3 - EXECUTION

3.1 EXAMINATION

- A. Examine areas and substrates, with Installer present, and including welded hollow-metal frames, cast-in anchors, and structural framing, for compliance with requirements and other conditions affecting performance of the Work.
- B. Proceed with installation only after unsatisfactory conditions have been corrected.

3.2 PREPARATION

- A. Suspended Assemblies: Coordinate installation of suspension systems with installation of overhead structure to ensure that inserts and other provisions for anchorages to building structure have been installed to receive hangers at spacing required to support the Work and that hangers will develop their full strength.
 - 1. Furnish concrete inserts and other devices indicated to other trades for installation in advance of time needed for coordination and construction.
- B. Coordination with Sprayed Fire-Resistive Materials:
 - 1. Before sprayed fire-resistive materials are applied, attach offset anchor plates or ceiling tracks to surfaces indicated to receive sprayed fire-resistive materials. Where offset anchor plates are required, provide continuous plates fastened to building structure not more than 24 inches o.c.
 - 2. After sprayed fire-resistive materials are applied, remove them only to extent necessary for installation of non-load-bearing steel framing. Do not reduce thickness of fire-resistive materials below that are required for fire-resistance ratings indicated. Protect adjacent fire-resistive materials from damage.

3.3 INSTALLATION, GENERAL

- A. Installation Standard: ASTM C754.

1. Gypsum Plaster Assemblies: Also comply with requirements in ASTM C841 that apply to framing installation.
 2. Portland Cement Plaster Assemblies: Also comply with requirements in ASTM C1063 that apply to framing installation.
 3. Gypsum Veneer Plaster Assemblies: Also comply with requirements in ASTM C844 that apply to framing installation.
 4. Gypsum Board Assemblies: Also comply with requirements in ASTM C840 that apply to framing installation.
- B. Install framing and accessories plumb, square, and true to line, with connections securely fastened.
- C. Install supplementary framing, and blocking to support fixtures, equipment services, heavy trim, grab bars, toilet accessories, furnishings, or similar construction.
- D. Install bracing at terminations in assemblies.
- E. Do not bridge building control and expansion joints with non-load-bearing steel framing members. Frame both sides of joints independently.

3.4 INSTALLING FRAMED ASSEMBLIES

- A. Install framing system components according to spacings indicated, but not greater than spacings required by referenced installation standards for assembly types.
1. Single-Layer Application: As required by horizontal deflection performance requirements unless otherwise indicated.
 2. Multilayer Application: As required by horizontal deflection performance requirements unless otherwise indicated.
 3. Tile Backing Panels: As required by horizontal deflection performance requirements unless otherwise indicated.
- B. Where studs are installed directly against exterior masonry walls or dissimilar metals at exterior walls, install isolation strip between studs and exterior wall.
- C. Install studs so flanges within framing system point in same direction.
- D. Install tracks at floors and overhead supports. Extend framing full height to structural supports or substrates above suspended ceilings except where partitions are indicated to terminate at suspended ceilings. Continue framing around ducts that penetrate partitions above ceiling.
1. Slip-Type Head Joints: Where framing extends to overhead structural supports, install to produce joints at tops of framing systems that prevent axial loading of finished assemblies.
 2. Door Openings: Screw vertical studs at jambs to jamb anchor clips on door frames; install track section (for cripple studs) at head and secure to jamb studs.
 - a. Install two studs at each jamb unless otherwise indicated.
 - b. Install cripple studs at head adjacent to each jamb stud, with a minimum 1/2-inch clearance from jamb stud to allow for installation of control joint in finished assembly.

- c. Extend jamb studs through suspended ceilings and attach to underside of overhead structure.
 3. Other Framed Openings: Frame openings other than door openings the same as required for door openings unless otherwise indicated. Install framing below sills of openings to match framing required above door heads.
 4. Fire-Resistance-Rated Partitions: Install framing to comply with fire-resistance-rated assembly indicated and support closures and to make partitions continuous from floor to underside of solid structure.
 - a. Firestop Track: Where indicated, install to maintain continuity of fire-resistance-rated assembly indicated.
 5. Sound-Rated Partitions: Install framing to comply with sound-rated assembly indicated.
 6. Curved Partitions:
 - a. Bend track to uniform curve and locate straight lengths so they are tangent to arcs.
 - b. Begin and end each arc with a stud, and space intermediate studs equally along arcs. On straight lengths of no fewer than two studs at ends of arcs, place studs 6 inches o.c.
- E. Direct Furring:
 1. Screw to wood framing.
 2. Attach to concrete or masonry with stub nails, screws designed for masonry attachment, or powder-driven fasteners spaced 24 inches o.c.
- F. Z-Shaped Furring Members:
 1. Erect insulation, specified in Section 07 2100 "Thermal Insulation," vertically and hold in place with Z-shaped furring members spaced 24 inches o.c.
 2. Except at exterior corners, securely attach narrow flanges of furring members to wall with concrete stub nails, screws designed for masonry attachment, or powder-driven fasteners spaced 24 inches o.c.
 3. At exterior corners, attach wide flange of furring members to wall with short flange extending beyond corner; on adjacent wall surface, screw-attach short flange of furring channel to web of attached channel. At interior corners, space second member no more than 12 inches from corner and cut insulation to fit.
- G. Installation Tolerance: Install each framing member so fastening surfaces vary not more than 1/8 inch from the plane formed by faces of adjacent framing.

3.5 INSTALLING CEILING SUSPENSION SYSTEMS

- A. Install suspension system components according to spacings indicated, but not greater than spacings required by referenced installation standards for assembly types.
 1. Hangers: 48 inches o.c.
 2. Carrying Channels (Main Runners): 48 inches o.c.
 3. Furring Channels (Furring Members): 16 inches o.c.

- B. Isolate suspension systems from building structure where they abut or are penetrated by building structure to prevent transfer of loading imposed by structural movement.
- C. Suspend hangers from building structure as follows:
 - 1. Install hangers plumb and free from contact with insulation or other objects within ceiling plenum that are not part of supporting structural or suspension system.
 - a. Splay hangers only where required to miss obstructions and offset resulting horizontal forces by bracing, countersplaying, or other equally effective means.
 - 2. Where width of ducts and other construction within ceiling plenum produces hanger spacings that interfere with locations of hangers required to support standard suspension system members, install supplemental suspension members and hangers in the form of trapezes or equivalent devices.
 - a. Size supplemental suspension members and hangers to support ceiling loads within performance limits established by referenced installation standards.
 - 3. Wire Hangers: Secure by looping and wire tying, either directly to structures or to inserts, eye screws, or other devices and fasteners that are secure and appropriate for substrate, and in a manner that will not cause hangers to deteriorate or otherwise fail.
 - 4. Flat Hangers: Secure to structure, including intermediate framing members, by attaching to inserts, eye screws, or other devices and fasteners that are secure and appropriate for structure and hanger, and in a manner that will not cause hangers to deteriorate or otherwise fail.
 - 5. Do not attach hangers to steel roof deck.
 - 6. Do not attach hangers to permanent metal forms. Furnish cast-in-place hanger inserts that extend through forms.
 - 7. Do not attach hangers to rolled-in hanger tabs of composite steel floor deck.
 - 8. Do not connect or suspend steel framing from ducts, pipes, or conduit.
- D. Fire-Resistance-Rated Assemblies: Wire tie furring channels to supports.
- E. Seismic Bracing: Sway-brace suspension systems with hangers used for support.
- F. Grid Suspension Systems: Attach perimeter wall track or angle where grid suspension systems meet vertical surfaces. Mechanically join main beam and cross-furring members to each other and butt-cut to fit into wall track.
- G. Installation Tolerances: Install suspension systems that are level to within 1/8 inch in 12 feet measured lengthwise on each member that will receive finishes and transversely between parallel members that will receive finishes.

END OF SECTION 09 2216

SECTION 092900 - GYPSUM BOARD ASSEMBLIES

PART 1 - GENERAL

1.1 RELATED DOCUMENTS

- A. Drawings and general provisions of the Contract, including General and Supplementary Conditions and Division 1 Specification Sections, apply to this Section.

1.2 SUMMARY

- A. This Section includes the following:
 - 1. Interior gypsum wallboard.
 - 2. Tile backing panels.
 - 3. Non-load-bearing steel framing.
- B. Related Sections include the following:
 - 1. Cold Formed Metal Framing
 - 2. Sheathing
 - 3. Painting

1.3 DEFINITIONS

- A. Gypsum Board Terminology: Refer to ASTM C 11 for definitions of terms for gypsum board assemblies not defined in this Section or in other referenced standards.

1.4 SUBMITTALS

- A. Product Data: For each type of product indicated.

1.5 QUALITY ASSURANCE

- A. Fire-Test-Response Characteristics: For gypsum board assemblies with fire-resistance ratings, provide materials and construction identical to those tested in assembly indicated according to ASTM E 119 by an independent testing and inspecting agency acceptable to authorities having jurisdiction.
- B. Sound Transmission Characteristics: For gypsum board assemblies with STC ratings, provide materials and construction identical to those tested in assembly indicated according to ASTM E 90 and classified according to ASTM E 413 by a qualified independent testing agency.
 - 1. STC-Rated Assemblies: Indicated by design designations from GA-600, "Fire Resistance Design Manual."

1.6 DELIVERY, STORAGE, AND HANDLING

- A. Deliver materials in original packages, containers, or bundles bearing brand name and identification of manufacturer or supplier.
- B. Store materials inside under cover and keep them dry and protected against damage from weather, direct sunlight, surface contamination, corrosion, construction traffic, and other causes. Stack gypsum panels flat to prevent sagging.

1.7 PROJECT CONDITIONS

- A. Environmental Limitations: Comply with ASTM C 840 requirements or gypsum board manufacturer's written recommendations, whichever are more stringent.

PART 2 - PRODUCTS

2.1 MANUFACTURERS

- A. Manufacturers: Subject to compliance with requirements, provide products by one of the following:
 - 1. Steel Framing and Furring:
 - a. Clark Steel Framing Systems.
 - b. Consolidated Systems, Inc.
 - c. Dale Industries, Inc. - Dale/Incor.
 - d. National Gypsum Company.
 - e. Scafco Corporation.
 - f. Western Metal Lath & Steel Framing Systems.
 - 2. Gypsum Board and Related Products:
 - a. American Gypsum Co.
 - b. G-P Gypsum Corp.
 - c. National Gypsum Company.
 - d. United States Gypsum Co.

2.2 STEEL SUSPENDED CEILING

- A. Components, General: Comply with ASTM C 754 for conditions indicated.
- B. Tie Wire: ASTM A 641/A 641M, Class 1 zinc coating, soft temper, 0.0625-inch- diameter wire, or double strand of 0.0475-inch- diameter wire.
- C. Carrying Channels: Cold-rolled, commercial-steel sheet with a base metal thickness of 0.0538 inch a minimum 1/2-inch- wide flange, with manufacturer's standard corrosion-resistant zinc coating.
 - 1. Depth: 1-1/2 inches .
- D. Furring Channels (Furring Members): Commercial-steel sheet with manufacturer's standard corrosion-resistant zinc coating.
 - 1. Hat-Shaped, Rigid Furring Channels: ASTM C 645, 7/8 inch deep.

2.3 STEEL PARTITION

- A. Components, General: As follows:
 - 1. Comply with ASTM C 754 for conditions indicated.
 - 2. Steel Sheet Components: Complying with ASTM C 645 requirements for metal and with manufacturer's standard corrosion-resistant zinc coating.
- B. Steel Studs and Runners: ASTM C 645.
 - 1. Minimum Uncoated-Steel Thickness: 0.0428 inch for wall studs and 0.0538 inch at door jambs and canopy.
 - 2. Depth: 3-5/8 inches or as indicated.
- C. Hat-Shaped, Rigid Furring Channels: ASTM C 645.
 - 1. Minimum Base Metal Thickness: 0.0312 inch.
 - 2. Depth: 7/8 inch.

- D. Cold-Rolled Furring Channels: 0.0538-inch bare steel thickness, with minimum 1/2-inch wide flange.
 - 1. Depth: 3/4 inch or as indicated.
 - 2. Furring Brackets: Adjustable, corrugated-edge type of steel sheet with minimum bare steel thickness of 0.0312 inch.
 - 3. Tie Wire: ASTM A 641/A 641M, Class 1 zinc coating, soft temper, 0.0625-inch-diameter wire, or double strand of 0.0475-inch-diameter wire.
- E. Fasteners for Metal Framing: Of type, material, size, corrosion resistance, holding power, and other properties required to fasten steel members to substrates.

2.4 INTERIOR GYPSUM WALLBOARD

- A. Panel Size: Provide in maximum lengths and widths available that will minimize joints in each area and correspond with support system indicated.
- B. Gypsum Wallboard: ASTM C 36.
 - 1. Type X:
 - a. Thickness: 5/8 inch.
 - b. Long Edges: Tapered.

2.5 TILE BACKING PANELS

- A. Panel Size: Provide in maximum lengths and widths available that will minimize joints in each area and correspond with support system indicated.
- B. Cementitious Backer Units: ANSI A118.9 and ASTM C 1288 or 1325, with manufacturer's standard edges.
 - 1. Thickness: 5/8 inch.
 - 2. Mold Resistance: ASTM D 3273, score of 10.

2.6 TRIM ACCESSORIES

- A. Interior Trim: ASTM C 1047.
 - 1. Material: Galvanized or aluminum-coated steel sheet or rolled zinc.
 - 2. Shapes:
 - a. LC-Bead (J-Bead): Use at exposed panel edges.

2.7 JOINT TREATMENT MATERIALS

- A. General: Comply with ASTM C 475.
- B. Joint Tape:
 - 1. Interior Gypsum Wallboard: Paper.
- C. Joint Compound for Interior Gypsum Wallboard: For each coat use formulation that is compatible with other compounds applied on previous or for successive coats.
 - 1. Prefilling: At open joints beveled panel edges, and damaged surface areas, use setting-type taping compound.
 - 2. Embedding and First Coat: For embedding tape and first coat on joints, fasteners, and trim flanges, use drying-type, all-purpose compound.
 - 3. Fill Coat: For second coat, use drying-type, all-purpose compound.
 - 4. Finish Coat: For third coat, use drying-type, all-purpose compound.
- D. Joint Compound for Tile Backing Panels:

1. Water-Resistant Gypsum Backing Board: Use setting-type taping and setting-type, sandable topping compounds.

2.8 AUXILIARY MATERIALS

- A. General: Provide auxiliary materials that comply with referenced installation standards and manufacturer's written recommendations.
- B. Steel Drill Screws: ASTM C 1002, unless otherwise indicated.
 1. Use screws complying with ASTM C 954 for fastening panels to steel members from 0.033 to 0.112 inch thick.
- C. Sound Attenuation Blankets: ASTM C 665, Type I (blankets without membrane facing) produced by combining thermosetting resins with mineral fibers manufactured from glass, slag wool, or rock wool.
 1. Fire-Resistance-Rated Assemblies: Comply with mineral-fiber requirements of assembly.

PART 3 - EXECUTION

3.1 EXAMINATION

- A. Examine areas and substrates, with Installer present, and including welded hollow-metal frames, cast-in anchors, and structural framing, for compliance with requirements and other conditions affecting performance. Proceed with installation only after unsatisfactory conditions have been corrected.

3.2 INSTALLING STEEL FRAMING, GENERAL

- A. Installation Standards: ASTM C 754, and ASTM C 840 requirements that apply to framing installation.
- B. Install supplementary framing, blocking, and bracing at terminations in gypsum board assemblies to support fixtures, equipment services, heavy trim, grab bars, toilet accessories, furnishings, or similar construction. Comply with details indicated and with gypsum board manufacturer's written recommendations or, if none available, with United States Gypsum's "Gypsum Construction Handbook."

3.3 INSTALLING STEEL SUSPENDED CEILING AND SOFFIT FRAMING

- A. Suspend ceiling hangers from building structure as follows:
 1. Install hangers plumb and free from contact with insulation or other objects within ceiling plenum that are not part of supporting structural or ceiling suspension system. Splay hangers only where required to miss obstructions and offset resulting horizontal forces by bracing, countersplaying, or other equally effective means.
 2. Secure wire hangers by looping and wire-tying, either directly to structures or to inserts, eyescrews, or other devices and fasteners that are secure and appropriate for substrate, and in a manner that will not cause them to deteriorate or otherwise fail
 3. Do not attach hangers to steel roof deck. Attach hangers to structural members.
- B. Wire-tie furring channels to supports, as required to comply with requirements for assemblies indicated.
- C. Install suspended steel framing components in sizes and spacings indicated, but not less than that required by the referenced steel framing and installation standards.
 1. Carrying Channels (Main Runners): 48 inches.

2. Furring Channels (Furring Members): 16 inches.

3.4 INSTALLING STEEL PARTITION

- A. Install tracks (runners) at floors, ceilings, and structural walls and columns where gypsum board assemblies abut other construction.
- B. Installation Tolerance: Install each steel framing and furring member so fastening surfaces vary not more than 1/8 inch from the plane formed by the faces of adjacent framing.
- C. Extend partition framing full height to structural supports or substrates above suspended ceilings, except where partitions are indicated to terminate at suspended ceilings. Continue framing over frames for doors and openings and frame around ducts penetrating partitions above ceiling to provide support for gypsum board.
- D. Install steel studs and furring at the following spacings:
 1. Single-Layer Construction: 16 inches, unless otherwise indicated.
- E. Install steel studs so flanges point in the same direction and leading edge or end of each panel can be attached to open (unsupported) edges of stud flanges first.
- F. Frame door openings to comply with GA-600 and with gypsum board manufacturer's applicable written recommendations, unless otherwise indicated. Screw vertical studs at jambs to jamb anchor clips on door frames; install runner track section (for cripple studs) at head and secure to jamb studs.
- G. Frame openings other than door openings the same as required for door openings, unless otherwise indicated. Install framing below sills of openings to match framing required above door heads.

3.5 APPLYING AND FINISHING PANELS, GENERAL

- A. Gypsum Board Application and Finishing Standards: ASTM C 840 and GA-216.
- B. Install sound attenuation blankets before installing gypsum panels, unless blankets are readily installed after panels have been installed on one side. Provide sound attenuation blankets in walls indicated on the drawings.
- C. Install ceiling board panels across framing to minimize the number of abutting end joints and to avoid abutting end joints in the central area of each ceiling. Stagger abutting end joints of adjacent panels not less than one framing member.
- D. Install gypsum panels with face side out. Butt panels together for a light contact at edges and ends with not more than 1/16 inch of open space between panels. Do not force into place.
- E. Locate edge and end joints over supports, except in ceiling applications where intermediate supports or gypsum board back-blocking is provided behind end joints. Do not place tapered edges against cut edges or ends. Stagger vertical joints on opposite sides of partitions. Do not make joints other than control joints at corners of framed openings.
- F. Attach gypsum panels to steel studs so leading edge or end of each panel is attached to open (unsupported) edges of stud flanges first.
- G. Attach gypsum panels to framing provided at openings and cutouts.

- H. STC-Rated Assemblies: Seal construction at perimeters, behind control and expansion joints, and at openings and penetrations with a continuous bead of acoustical sealant. Install acoustical sealant at both faces of partitions at perimeters and through penetrations. Comply with ASTM C 919 and manufacturer's written recommendations for locating edge trim and closing off sound-flanking paths around or through gypsum board assemblies, including sealing partitions above acoustical ceilings.
- I. Space fasteners in gypsum panels according to referenced gypsum board application and finishing standard and manufacturer's written recommendations.

3.6 PANEL APPLICATION METHODS

- A. Single-Layer Application:
 - 1. On ceilings, apply gypsum panels before wall/partition board application to the greatest extent possible and at right angles to framing, unless otherwise indicated.
 - 2. On partitions/walls, apply gypsum panels horizontally (perpendicular to framing), unless otherwise indicated or required by fire-resistance-rated assembly, and minimize end joints.
 - a. Stagger abutting end joints not less than one framing member in alternate courses of board.
- B. Multilayer Application on Ceilings: Apply gypsum board indicated for base layers before applying base layers on walls/partitions; apply face layers in same sequence. Apply base layers at right angles to framing members and offset face-layer joints 1 framing member, 16 inches minimum, from parallel base-layer joints, unless otherwise indicated or required by fire-resistance-rated assembly.
- C. Single-Layer Fastening Methods: Apply gypsum panels to supports with steel drill screws.
- D. Multilayer Fastening Methods: Fasten base layers and face layers separately to supports with screws.
- E. Tile Backing Panels:
 - 1. Water-Resistant Gypsum Backing Board: Install at showers. Install with 1/4-inch gap where panels abut other construction or penetrations.
 - 2. Areas Not Subject to Wetting: Install standard gypsum wallboard panels to produce a flat surface except at shower locations indicated to receive water-resistant panels.
 - 3. Where tile backing panels abut other types of panels in the same plane, shim surfaces to produce a uniform plane across panel surfaces.

3.7 INSTALLING TRIM ACCESSORIES

- A. General: For trim with back flanges intended for fasteners, attach to framing with same fasteners used for panels. Otherwise, attach trim according to manufacturer's written instructions.

3.8 FINISHING GYPSUM BOARD ASSEMBLIES

- A. General: Treat gypsum board joints, interior angles, edge trim, control joints, penetrations, fastener heads, surface defects, and elsewhere as required to prepare gypsum board surfaces for decoration. Promptly remove residual joint compound from adjacent surfaces.
- B. Prefill open joints, beveled edges, and damaged surface areas.
- C. Apply joint tape over gypsum board joints, except those with trim having flanges not intended for tape.
- D. Gypsum Board Finish Levels: Finish panels to levels indicated below, according to ASTM C 840, for locations indicated:
 - 1. Level 1: Embed tape at joints in ceiling plenum areas, concealed areas, and where indicated.

2. Level 5: Embed tape and apply separate first, fill, and finish coats of joint compound to tape, fasteners, and trim flanges, and apply skim coat of joint compound over entire surface where indicated.

END OF SECTION 092900

SECTION 093013 - CERAMIC TILING**PART 1 - GENERAL****1.1 RELATED DOCUMENTS**

- A. Drawings and general provisions of the Contract, including General and Supplementary Conditions and Division 1 Specification Sections, apply to this Section.

1.2 SUMMARY

- A. This Section includes the following:
 - 1. Quarry tile.
- B. Related Sections include the following:
 - 1. Division 9 Section "Gypsum Board Assemblies" for water-resistant backer board installed in gypsum wallboard assemblies.

1.3 DEFINITIONS

- A. Facial Dimension: Nominal tile size as defined in ANSI A137.1.
- B. Installation products: ANSI A118
- C. Installation procedures ANSI 108

1.4 SUBMITTALS

- A. Product Data: For each type of tile, mortar, grout, and other products specified.
- B. Shop Drawings: Show locations for each type of tile and tile pattern.
- C. Samples for Initial Selection: For each type of tile and grout indicated. Include Samples of accessories involving color selection.

1.5 QUALITY ASSURANCE

- A. Source Limitations for Tile: Obtain all tile of same type and color or finish from one source or producer.
 - 1. Obtain tile from same production run and of consistent quality in appearance and physical properties for each contiguous area.

1.6 DELIVERY, STORAGE, AND HANDLING

- A. Deliver and store packaged materials in original containers with seals unbroken and labels intact until time of use. Comply with requirement of ANSI A137.1 for labeling sealed tile packages.
- B. Store liquid latexes and emulsion adhesives in unopened containers and protected from freezing.

1.7 PROJECT CONDITIONS

- A. Environmental Limitations: Do not install tile until construction in spaces is completed and ambient temperature and humidity conditions are being maintained to comply with referenced standards and manufacturer's written instructions.

1.8 EXTRA MATERIALS

- A. Deliver extra materials to Owner. Furnish extra materials described below that match products installed, are packaged with protective covering for storage, and are identified with labels describing contents.
 - 1. Tile and Trim Units: Furnish quantity of full-size units equal to 3 percent of amount installed, for each type, composition, color, pattern, and size indicated.

PART 2 - PRODUCTS

2.1 MANUFACTURERS

- A. In other Part 2 articles where titles below introduce lists, the following requirements apply for product selection:
 - 1. Manufacturers: Subject to compliance with requirements, provide products by one of the following manufacturers specified:

2.2 PRODUCTS, GENERAL

- A. ANSI Ceramic Tile Standard: Provide tile that complies with ANSI A137.1, "Specifications for Ceramic Tile," for types, compositions, and other characteristics indicated.
 - 1. Provide tile complying with Standard Grade requirements, unless otherwise indicated.
- B. Colors, Textures, and Patterns: Where manufacturer's standard products are indicated for tile, grout, and other products requiring selection of colors, surface textures, patterns, and other appearance characteristics, provide specific products or materials complying with the following requirements:
 - 1. Provide Architect's selections from manufacturer's full range of colors, textures, and patterns for products of type indicated. Several colors are to be used as indicated on the drawings.

2.3 TILE PRODUCTS

- A. Unglazed Quarry Tile: Square-edged flat tile as follows:
 - 1. Wearing Surface: Nonabrasive, textured
 - 2. Facial Dimensions: 6 by 6 inches .
 - 3. Thickness: 1/2 inch
 - 4. Face: Plain
 - 5. Price Group (see finish schedule in drawings for model, style, accent pattern, etc.)

2.4 SETTING AND GROUTING MATERIALS

- A. Use non-shrink high strength grout for ceramic tilework.
- B. Manufacturers:
 - 1. Custom Building Products.
 - 2. Mapei
 - 3. Laticrete International
 - 4. TEC Specialty Products Inc.
 - 5. Bostik, Inc.

- C. Portland Cement Mortar (Thickset) Installation Materials: ANSI A108.1A and as specified below:
 - 1. Cleavage Membrane: Asphalt felt, ASTM D 226, Type I (No. 15); or polyethylene sheeting, ASTM D 4397, 4.0 mils thick.
- D. Dry-Set Portland Cement Mortar (Thin Set): ANSI A118.1 and ISO 13007
 - 1. For wall applications, provide nonsagging mortar that complies with Paragraph C-4.6.1 in addition to the other requirements in ANSI A118.1 and ISO 13007 C2TES1P1.
- E. Latex-Portland Cement Mortar (Thin Set): ANSI A118.4 and ISO 13007, consisting of the following:
 - 1. Prepackaged dry-mortar mix containing dry, redispersible, ethylene vinyl acetate additive to which only water must be added at Project site.
 - a. For wall applications, provide nonsagging mortar that complies with Paragraph F-4.6.1 in addition to the other requirements in ANSI A118.4 and ISO 13007 C2TES1P1.
- F. Epoxy/Resin-Based Thinset Mortar: Solvent-free, 100%-solids epoxy setting floor and wall mortar that is suited for areas where most chemical-resistant setting material is necessary. ISO 13007 R2.
 - 1. For floor and base in kitchen area: MAPEI, Kerapoxy 410
- G. Sand-Portland Cement Grout: ANSI A108.10 and ISO 13007 CG2WA, composed of white or gray cement and white or colored aggregate as required to produce color indicated.
- H. Epoxy/Resin-Based Grout: ISO 13007 RG 100%-solids epoxy grout, with high chemical, stain, and enzymatic resistance.
 - 1. For floor and base in kitchen area: MAPEI, Kerapoxy IEG.

2.5 ELASTOMERIC SEALANTS

- A. General: Provide manufacturer's standard chemically curing, elastomeric sealants of base polymer and characteristics required.
- B. Colors: Provide colors of exposed sealants to match colors of grout in tile adjoining sealed joints, unless otherwise indicated.
 - 1. Products:
 - a. Bostik; Chem-Calk 550.
 - b. Mameco International, Inc.; Vulkem 245.
 - c. Tremco, Inc.; THC-900.

2.6 MISCELLANEOUS MATERIALS

- A. Trowelable Underlayments and Patching Compounds: Latex-modified, portland cement-based formulation provided or approved by manufacturer of tile-setting materials for installations indicated.
 - 1. Metal Edge Strips: Angle or L-shaped brushed aluminum or stainless steel, height to match tile and setting-bed thickness.
- B. Tile Cleaner: A neutral cleaner capable of removing soil and residue without harming tile and grout surfaces, specifically approved for materials and installations indicated by tile and grout manufacturers.

- C. Grout Sealer: Manufacturer's standard product for sealing grout joints that does not change color or appearance of grout.
- D. Metal Trims: Provide metal strips (manufactured by Schluter) along tile edge and transitions as indicated on drawings.

2.7 MIXING MORTARS AND GROUT

- A. Use epoxy based grout for floors and cove base on walls conforming to ISO 13007 R2 and ISO 13007 RG Enzyme resistant formula, respectively. Equal to Mapei "OptiColor".
- B. Mix mortars and grouts to comply with referenced standards and mortar and grout manufacturers' written instructions.
- C. Add materials, water, and additives in accurate proportions.
- D. Obtain and use type of mixing equipment, mixer speeds, mixing containers, mixing time, and other procedures to produce mortars and grouts of uniform quality with optimum performance characteristics for installations indicated.

PART 3 - EXECUTION

3.1 EXAMINATION

- A. Examine substrates, areas, and conditions where tile will be installed, with Installer present, for compliance with requirements for installation tolerances and other conditions affecting performance of installed tile.
 - 1. Verify that substrates for setting tile are firm; dry; clean; free of oil, waxy films, and curing compounds; and within flatness tolerances required by referenced ANSI A108 Series of tile installation standards for installations indicated.
 - 2. Verify that installation of grounds, anchors, recessed frames, electrical and mechanical units of work, and similar items located in or behind tile has been completed before installing tile.
 - 3. Verify that joints and cracks in tile substrates are coordinated with tile joint locations; if not coordinated, adjust joint locations in consultation with Architect.
- B. Proceed with installation only after unsatisfactory conditions have been corrected.

3.2 PREPARATION

- A. Remove coatings, including curing compounds and other substances that contain soap, wax, oil, or silicone, that are incompatible with tile-setting materials.
- B. Provide concrete substrates for tile floors installed with adhesives or thin-set mortar that comply with flatness tolerances specified in referenced ANSI A108 Series of tile installation standards.
 - 1. Fill cracks, holes, and depressions with trowelable leveling and patching compound according to tile-setting material manufacturer's written instructions. Use product specifically recommended by tile-setting material manufacturer.
 - 2. Remove protrusions, bumps, and ridges by sanding or grinding.

3.3 INSTALLATION, GENERAL

- A. ANSI Tile Installation Standards: Comply with parts of ANSI A108 Series "Specifications for Installation of Ceramic Tile" that apply to types of setting and grouting materials and to methods indicated in ceramic tile installation schedules.

- B. TCA Installation Guidelines: TCA's "Handbook for Ceramic Tile Installation." Comply with TCA installation methods indicated in ceramic tile installation schedules.
- C. Extend tile work into recesses and under or behind equipment and fixtures to form complete covering without interruptions, unless otherwise indicated. Terminate work neatly at obstructions, edges, and corners without disrupting pattern or joint alignments.
- D. Accurately form intersections and returns. Perform cutting and drilling of tile without marring visible surfaces. Carefully grind cut edges of tile abutting trim, finish, or built-in items for straight aligned joints. Fit tile closely to electrical outlets, piping, fixtures, and other penetrations so plates, collars, or covers overlap tile.
- E. Jointing Pattern: Lay tile in grid pattern, unless otherwise indicated. Align joints when adjoining tiles on floor, base, walls, and trim are same size. Lay out tile work and center tile fields in both directions in each space or on each wall area. Adjust to minimize tile cutting. Provide uniform joint widths, unless otherwise indicated.
- F. Lay out tile wainscots to next full tile beyond dimensions indicated.
- G. Use crack isolation mat where poured gypsum is used for leveling.
- H. Grout tile to comply with requirements of the following tile installation standards:
 - 1. For ceramic tile grouts (sand-portland cement; dry-set, commercial portland cement; and latex-portland cement grouts), comply with ANSI A108.10.

3.4 WATERPROOFING INSTALLATION

- A. Use bonded waterproof membrane together with fiberglass tape in corners for floors and minimum 18" up walls for wet locations.
- B. Install waterproofing to comply with ANSI A108.13 and waterproofing manufacturer's written instructions to produce waterproof membrane of uniform thickness bonded securely to substrate.
- C. Do not install tile over waterproofing until waterproofing has cured and been tested to determine that it is watertight.

3.5 FLOOR TILE INSTALLATION

- A. General: Install tile to comply with requirements in the Floor Tile Installation Schedule, including those referencing TCA installation methods and ANSI A108 Series of tile installation standards.
 - 1. For installations indicated below, follow procedures in ANSI A108 Series tile installation standards for providing 95 percent mortar coverage.
 - a. Tile floors in wet areas.
 - b. Tile floors composed of tiles 8 by 8 inches or larger.
- B. Joint Widths: Install tile on floors with the following joint widths:
 - 1. Ceramic Mosaic Tile: 1/8 inch.
 - 2. Quarry Tile: 1/4 inch.
 - 3. Glazed Wall Tile: 1/16 inch.
- C. Stone Thresholds: Install stone thresholds at locations indicated; set in same type of setting bed as abutting field tile, unless otherwise indicated.
 - 1. Set thresholds in latex-portland cement mortar for locations where mortar bed would otherwise be exposed above adjacent nontile floor finish.

- D. Grout Sealer: Apply grout sealer to cementitious grout joints according to grout-sealer manufacturer's written instructions. As soon as grout sealer has penetrated grout joints, remove excess sealer and sealer that has gotten on tile faces by wiping with soft cloth.
- E. Cover finished work with Kraft paper for minimum 72 hours during drying.

3.6 WALL AND CEILING TILE INSTALLATION

- A. Install types of tile designated for wall installations to comply with requirements in the Wall Tile Installation Schedule, including those referencing TCA installation methods and ANSI setting-bed standards.
- B. Joint Widths: Install tile on walls with the following joint widths:
 - 1. Glazed Wall Tile: 4 x 4 1/8 inch
6 x 6 1/16 inch

3.7 CLEANING AND PROTECTING

- A. Cleaning: On completion of placement and grouting, clean all ceramic tile surfaces so they are free of foreign matter.
 - 1. Remove latex-portland cement grout residue from tile as soon as possible.
 - 2. Clean grout smears and haze from tile according to tile and grout manufacturer's written instructions, but no sooner than 10 days after installation. Use only cleaners recommended by tile and grout manufacturers and only after determining that cleaners are safe to use by testing on samples of tile and other surfaces to be cleaned. Protect metal surfaces and plumbing fixtures from effects of cleaning. Flush surfaces with clean water before and after cleaning.
- B. Prohibit foot and wheel traffic from tiled floors for at least seven days after grouting is completed.

3.8 FLOOR TILE INSTALLATION SCHEDULE

- A. Tile Installation FTI-#1: (for slab on grade floors with recess) Interior floor installation on concrete; cement mortar bed (thickset) with cleavage membrane; TCA F111 and ANSI A108.1B
 - 1. Tile Type: Unglazed quarry
 - 2. Mortar: Latex- portland cement mortar.
 - 3. Grout: Sand-portland cement grout or epoxy.

END OF SECTION 093013

SECTION 096530 - RESILIENT WALL BASE AND ACCESSORIES

PART 1 - GENERAL

1.1 RELATED DOCUMENTS

- A. Drawings and general provisions of the Contract, including General and Supplementary Conditions and Division 1 Specification Sections, apply to this Section.

1.2 SUMMARY

- A. This Section includes the following:
 - 1. Resilient wall base for Division 9 Sections 096510.
- B. Related Sections include the following:
 - 1. Division 9 Sections 096510.

1.3 SUBMITTALS

- A. Product Data: For each type of product specified.
- B. Samples for Initial Selection: Manufacturer's standard sample sets consisting of sections of units showing the full range of colors and patterns available for each type of product indicated.

1.4 QUALITY ASSURANCE

- A. Installer Qualifications: Engage an experienced installer to perform work of this Section who has specialized in installing resilient products similar to those required for this Project and with a record of successful in-service performance.
- B. Source Limitations: Obtain each type and color of product specified from one source with resources to provide products of consistent quality in appearance and physical properties without delaying the Work.

1.5 DELIVERY, STORAGE, AND HANDLING

- A. Deliver products to Project site in manufacturer's original, unopened cartons and containers, each bearing names of product and manufacturer, Project identification, and shipping and handling instructions.

1.6 PROJECT CONDITIONS

- A. Maintain a temperature of not less than 70 deg F or more than 95 deg F in spaces to receive resilient products for at least 48 hours before installation, during installation, and for at least 48 hours after installation, unless manufacturer's written recommendations specify longer time periods. After post installation period, maintain a temperature of not less than 55 deg F or more than 95 deg F.
- B. Do not install products until they are at the same temperature as the space where they are to be installed.

- C. For resilient products installed on traffic surfaces, close spaces to traffic during installation and for time period after installation recommended in writing by manufacturer.
- D. Coordinate resilient product installation with other construction to minimize possibility of damage and soiling during remainder of construction period. Install resilient products after other finishing operations, including painting, have been completed.

1.7 EXTRA MATERIALS

- A. Furnish extra materials described below that match products installed, are packaged with protective covering for storage, and are identified with labels describing contents.
 - 1. Furnish not less than 10 linear feet for each 500 linear feet or fraction thereof, of each different type, color, pattern, and size of resilient product installed.
 - 2. Deliver extra materials to Owner.

PART 2 - PRODUCTS

2.1 MANUFACTURERS

- A. Products: Subject to compliance with requirements, provide one of the products indicated for each designation in the Resilient Wall Base and Accessory Schedule at the end of Part 3.

2.2 RESILIENT WALL BASE

- A. Rubber Wall Base: Products complying with FS SS-W-40, Type I and with requirements specified in the Resilient Wall Base and Accessory Schedule.

2.3 RESILIENT ACCESSORIES

- A. Rubber Accessories: Products complying with requirements specified in the Resilient Wall Base and Accessory Schedule.

2.4 INSTALLATION ACCESSORIES

- A. Trowelable Leveling and Patching Compounds: Latex-modified, portland-cement-based formulation provided or approved by resilient product manufacturer for applications indicated.
- B. Adhesives: Water-resistant type recommended by manufacturer to suit resilient products and substrate conditions indicated.

PART 3 - EXECUTION

3.1 EXAMINATION

- A. Examine substrates, areas, and conditions where installation of resilient products will occur, with Installer present, for compliance with manufacturer's requirements, including those for maximum moisture content. Verify that substrates and conditions are satisfactory for resilient product installation and comply with requirements specified. Do not proceed with installation until unsatisfactory conditions have been corrected.

3.2 PREPARATION

- A. General: Comply with manufacturer's written installation instructions for preparing substrates indicated to receive resilient products.
- B. Use trowelable leveling and patching compounds, according to manufacturer's written instructions, to fill cracks, holes, and depressions in substrates.
- C. Remove coatings, including curing compounds, and other substances that are incompatible with adhesives and that contain soap, wax, oil, or silicone, using mechanical methods recommended by manufacturer. Do not use solvents.
- D. Broom and vacuum clean substrates to be covered immediately before installing resilient products. After cleaning, examine substrates for moisture, alkaline salts, carbonation, or dust. Do not proceed with installation until unsatisfactory conditions have been corrected.

3.3 INSTALLATION

- A. General: Install resilient products according to manufacturer's written installation instructions.
- B. Apply resilient wall base to walls, columns, pilasters, casework and cabinets in toe spaces, and other permanent fixtures in rooms and areas where base is required.
 - 1. Install wall base in lengths as long as practicable without gaps at seams and with tops of adjacent pieces aligned.
 - 2. Tightly adhere wall base to substrate throughout length of each piece, with base in continuous contact with horizontal and vertical substrates.
 - 3. Do not stretch base during installation.
 - 4. On masonry surfaces or other similar irregular substrates, fill voids along top edge of resilient wall base with manufacturer's recommended adhesive filler material.
 - 5. Form outside corners on job, from straight pieces of maximum lengths possible, without whitening at bends. Shave back of base at points where bends occur and remove strips perpendicular to length of base that are only deep enough to produce a snug fit without removing more than half the wall base thickness.
 - 6. Form inside corners on job, from straight pieces of maximum lengths possible, by cutting an inverted V-shaped notch in toe of wall base at the point where corner is formed. Shave back of base where necessary to produce a snug fit to substrate.
- C. Place resilient products so they are butted to adjacent materials and bond to substrates with adhesive. Install reducer strips at edges of flooring that would otherwise be exposed.
- D. Apply resilient products to stairs as indicated and according to manufacturer's written installation instructions.

3.4 CLEANING AND PROTECTING

- A. Perform the following operations immediately after installing resilient products:
 - 1. Remove adhesive and other surface blemishes using cleaner recommended by resilient product manufacturers.
 - 2. Sweep or vacuum horizontal surfaces thoroughly.
 - 3. Do not wash resilient products until after time period recommended by resilient product manufacturer.
 - 4. Damp-mop or sponge resilient products to remove marks and soil.

- B. Protect resilient products against mars, marks, indentations, and other damage from construction operations and placement of equipment and fixtures during the remainder of construction period. Use protection methods indicated or recommended in writing by resilient product manufacturer.

3.5 RESILIENT WALL BASE AND ACCESSORY SCHEDULE

- A. Rubber Wall Base: Where this designation is indicated, provide rubber wall base complying with the following and as indicated on the Drawings:
 - 1. Products: As follows:
 - a. Burke Flooring Products Division – Burke Industries, Inc.
 - b. Flexco Div. – Textile Rubber Co.
 - c. Johnson Rubber Co., Inc.
 - d. R.C. Musson Rubber Co, Inc.
 - e. Roppe Rubber Corp.
 - 2. Color and Pattern: As selected by Architect from manufacturer's full range of colors and patterns produced for rubber wall base complying with requirements indicated.
 - 3. Style: Pinnacle (by Roppe or equivalent).
 - 4. Minimum Thickness: 1/8 inch.
 - 5. Height: 4 inches.
 - 6. Lengths: Coils in lengths standard with manufacturer, but not less than 96 feet.
 - 7. Surface: Smooth.
- B. Rubber Accessory: Provide rubber accessory molding complying with the following:
 - 1. Products: As follows:
 - a. Burke Flooring Products Division – Burke Industries, Inc.
 - b. Flexco Div. – Textile Rubber Co.
 - c. Johnson Rubber Co., Inc.
 - d. R.C. Musson Rubber Co, Inc.
 - e. Roppe Rubber Corp.
 - f. RCA Rubber Company
 - 2. Color: As selected by Architect from manufacturer's full range of colors produced for rubber accessory molding complying with requirements indicated.
 - 3. Product Description: Carpet edge for glue-down applications. Reducer strip for resilient flooring. Tile and carpet joiner.

END OF SECTION 096530

SECTION 099000 - PAINTING**PART 1 - GENERAL****1.1 RELATED DOCUMENTS**

- A. Drawings and general provisions of the Contract, including General and Supplementary Conditions and Division 1 Specification Sections, apply to this Section.

1.2 SUMMARY

- A. This Section includes surface preparation and field painting of the following:
 - 1. Exposed exterior items and surfaces.
 - 2. Exposed interior items and surfaces.
- B. Paint exposed surfaces, except where the paint schedules indicate that a surface or material is not to be painted or is to remain natural. If the paint schedules do not specifically mention an item or a surface, paint the item or surface the same as similar adjacent materials or surfaces whether or not schedules indicate colors. If the schedules do not indicate color or finish, the Architect will select from standard colors and finishes available.
- C. Do not paint prefinished items, concealed surfaces, finished metal surfaces, operating parts, and labels.
 - 1. Prefinished items include the following factory-finished components:
 - a. Architectural woodwork and casework.
 - b. Metal toilet enclosures.
 - c. Metal lockers.
 - d. Elevator entrance doors and frames.
 - e. Elevator equipment.
 - f. Light fixtures.
 - 2. Concealed surfaces include walls or ceilings in the following generally inaccessible spaces:
 - a. Furred areas.
 - b. Ceiling plenums.
 - c. Pipe spaces.
 - d. Duct shafts.
 - e. Elevator shafts.
 - 3. Labels: Do not paint over Underwriters Laboratories (UL), Factory Mutual (FM), or other code-required labels or equipment name, identification, performance rating, or nomenclature plates.

1.3 SUBMITTALS

- A. Product Data: For each paint system specified. Include block fillers and primers.
 - 1. Manufacturer's Information: Provide manufacturer's technical information, including label analysis and instructions for handling, storing, and applying each coating material proposed for use.
- B. Samples for Initial Selection: Manufacturer's color charts showing the full range of colors available for each type of finish-coat material indicated.

1.4 QUALITY ASSURANCE

- A. Applicator Qualifications: Engage an experienced applicator who has completed painting system applications similar in material and extent to that indicated for this Project with a record of successful in-service performance.
- B. Source Limitations: Obtain block fillers, primers, and undercoat materials for each coating system from the same manufacturer as the finish coats.

1.5 DELIVERY, STORAGE, AND HANDLING

- A. Deliver materials to the Project Site in manufacturer's original, unopened packages and containers bearing manufacturer's name and label, and the following information:
 - 1. Product name or title of material.
 - 2. Application instructions.
 - 3. Color name and number.
- B. Store materials not in use in tightly covered containers in a well-ventilated area at a minimum ambient temperature of 45 deg F. Maintain containers used in storage in a clean condition, free of foreign materials and residue.
 - 1. Protect from freezing. Keep storage area neat and orderly. Remove oily rags and waste daily. Take necessary measures to ensure that workers and work areas are protected from fire and health hazards resulting from handling, mixing, and application.

1.6 PROJECT CONDITIONS

- A. Apply water-based paints only when the temperature of surfaces to be painted and surrounding air temperatures are between 50 and 90 deg F.
- B. Apply solvent-thinned paints only when the temperature of surfaces to be painted and surrounding air temperatures are between 45 and 95 deg F.
- C. Do not apply paint in snow, rain, fog, or mist; or when the relative humidity exceeds 85 percent; or at temperatures less than 5 deg F above the dew point; or to damp or wet surfaces.
 - 1. Painting may continue during inclement weather if surfaces and areas to be painted are enclosed and heated within temperature limits specified by manufacturer during application and drying periods.

1.7 EXTRA MATERIALS

- A. Furnish extra paint materials from the same production run as the materials applied in the quantities described below. Package paint materials in unopened, factory-sealed containers for storage and identify with labels describing contents. Deliver extra materials to the Owner.
 - 1. Quantity: Furnish the Owner with an additional 1 gal. of each material and color applied.

PART 2 - PRODUCTS

2.1 MANUFACTURERS

- A. Available Products: Subject to compliance with requirements, products that may be incorporated into the Work include, but are not limited to, products listed in the paint schedules.
 - 1. Benjamin Moore & Co. (Moore).

2. Glidden Co. (The) (Glidden).
3. ICI Dulux Paint Centers (ICI Dulux Paints).
4. PPG Industries, Inc. (PPG).
5. Pratt & Lambert, Inc. (P & L).
6. Sherwin-Williams Co. (S-W).

2.2 PAINT MATERIALS, GENERAL

- A. Material Compatibility: Provide block fillers, primers, undercoats, and finish-coat materials that are compatible with one another and the substrates indicated under conditions of service and application, as demonstrated by manufacturer based on testing and field experience.
- B. Material Quality: Provide manufacturer's best-quality paint material of the various coating types specified. Paint-material containers not displaying manufacturer's product identification will not be acceptable.
- C. Colors: Provide color selections made by the Architect.

PART 3 - EXECUTION

3.1 EXAMINATION

- A. Examine substrates, areas, and conditions, with the Applicator present, under which painting will be performed for compliance with paint application requirements.
 1. Do not begin to apply paint until unsatisfactory conditions have been corrected and surfaces receiving paint are thoroughly dry.
 2. Start of painting will be construed as the Applicator's acceptance of surfaces and conditions within a particular area.

3.2 PREPARATION

- A. General: Remove hardware and hardware accessories, plates, machined surfaces, lighting fixtures, and similar items already installed that are not to be painted. If removal is impractical or impossible because of the size or weight of the item, provide surface-applied protection before surface preparation and painting.
 1. After completing painting operations in each space or area, reinstall items removed using workers skilled in the trades involved.
- B. Cleaning: Before applying paint or other surface treatments, clean the substrates of substances that could impair the bond of the various coatings. Remove oil and grease before cleaning.
 1. Schedule cleaning and painting so dust and other contaminants from the cleaning process will not fall on wet, newly painted surfaces.
- C. Surface Preparation: Clean and prepare surfaces to be painted according to manufacturer's written instructions for each particular substrate condition and as specified.
 1. Cementitious Materials: Prepare concrete, concrete masonry block, cement plaster, and mineral-fiber-reinforced cement panel surfaces to be painted. Remove efflorescence, chalk, dust, dirt, grease, oils, and release agents. Roughen as required to remove glaze. If hardeners or sealers have been used to improve curing, use mechanical methods of surface preparation.
 2. Wood: Clean surfaces of dirt, oil, and other foreign substances with scrapers, mineral spirits, and sandpaper, as required. Sand surfaces exposed to view smooth and dust off.

3. Ferrous Metals: Clean ungalvanized ferrous-metal surfaces that have not been shop coated; remove oil, grease, dirt, loose mill scale, and other foreign substances. Use solvent or mechanical cleaning methods that comply with the Steel Structures Painting Council's (SSPC) recommendations.
- D. Materials Preparation: Mix and prepare paint materials according to manufacturer's written instructions.
1. Maintain containers used in mixing and applying paint in a clean condition, free of foreign materials and residue.
 2. Stir material before application to produce a mixture of uniform density. Stir as required during application. Do not stir surface film into material. If necessary, remove surface film and strain material before using.
 3. Use only thinners approved by paint manufacturer and only within recommended limits.
- E. Tinting: Tint each undercoat a lighter shade to simplify identification of each coat when multiple coats of the same material are applied. Tint undercoats to match the color of the finish coat, but provide sufficient differences in shade of undercoats to distinguish each separate coat.

3.3 APPLICATION

- A. General: Apply paint according to manufacturer's written instructions. Use applicators and techniques best suited for substrate and type of material being applied.
1. Paint colors, surface treatments, and finishes are indicated in the schedules.
 2. Do not paint over dirt, rust, scale, grease, moisture, scuffed surfaces, or conditions detrimental to formation of a durable paint film.
 3. Provide finish coats that are compatible with primers used.
 4. The term "exposed surfaces" includes areas visible when permanent or built-in fixtures, convector covers, covers for finned-tube radiation, grilles, and similar components are in place. Extend coatings in these areas, as required, to maintain the system integrity and provide desired protection.
 5. Paint surfaces behind movable equipment and furniture the same as similar exposed surfaces. Before the final installation of equipment, paint surfaces behind permanently fixed equipment or furniture with prime coat only.
 6. Finish exterior doors on tops, bottoms, and side edges the same as exterior faces.
 7. Sand lightly between each succeeding enamel or varnish coat.
- B. Scheduling Painting: Apply first coat to surfaces that have been cleaned, pretreated, or otherwise prepared for painting as soon as practicable after preparation and before subsequent surface deterioration.
1. The number of coats and the film thickness required are the same regardless of application method. Do not apply succeeding coats until the previous coat has cured as recommended by the manufacturer. If sanding is required to produce a smooth, even surface according to manufacturer's written instructions, sand between applications.
 2. Omit primer on metal surfaces that have been shop primed and touchup painted.
 3. If undercoats, stains, or other conditions show through final coat of paint, apply additional coats until paint film is of uniform finish, color, and appearance. Give special attention to ensure edges, corners, crevices, welds, and exposed fasteners receive a dry film thickness equivalent to that of flat surfaces.
 4. Allow sufficient time between successive coats to permit proper drying. Do not recoat surfaces until paint has dried to where it feels firm, does not deform or feel sticky under moderate thumb pressure, and where application of another coat of paint does not cause the undercoat to lift or lose adhesion.
- C. Application Procedures: Apply paints and coatings by brush, roller, spray, or other applicators according to manufacturer's written instructions.

- D. Minimum Coating Thickness: Apply paint materials no thinner than manufacturer's recommended spreading rate. Provide the total dry film thickness of the entire system as recommended by the manufacturer.
- E. Mechanical and Electrical Work: Painting of mechanical and electrical work is limited to items exposed in equipment rooms and in occupied spaces.
- F. Block Fillers: Apply block fillers to concrete masonry block at a rate to ensure complete coverage with pores filled.

3.4 CLEANING

- A. Cleanup: At the end of each workday, remove empty cans, rags, rubbish, and other discarded paint materials from the site.
 - 1. After completing painting, clean glass and paint-spattered surfaces. Remove spattered paint by washing and scraping. Be careful not to scratch or damage adjacent finished surfaces.

3.5 PROTECTION

- A. Protect work of other trades, whether being painted or not, against damage by painting. Correct damage by cleaning, repairing or replacing, and repainting, as approved by Architect.
- B. Provide "Wet Paint" signs to protect newly painted finishes. Remove temporary protective wrappings provided by others to protect their work after completing painting operations.
 - 1. At completion of construction activities of other trades, touch up and restore damaged or defaced painted surfaces. Comply with procedures specified in PDCA P1.

3.6 EXTERIOR PAINT SCHEDULE

- A. Ferrous Metal and Galvanized Metals: Provide the following system or comparable one from one of the approved manufacturers.
 - 1. Semi-Gloss Finish
 - Primer: Pro Industrial Pro-Cryl Universal Metal Primer, B66-310, <100 g/L VOC
 - 1st coat: Pro Industrial Zero VOC Acrylic Semi-Gloss, B66-650 series, 0 g/L VOC
 - 2nd coat: Pro Industrial Zero VOC Acrylic Semi-Gloss, B66-650 series, 0 g/L VOC
- B. Exposed Concrete: Provide anti graffiti coating for all exposed exterior concrete retaining walls and benches:
 - 1. S-W Anti-Graffiti Coating or Architect's approved equal.
- C. Exposed Concrete Masonry Units: Provide water-based graffiti and water repellent for CMU walls (all sides) as follows:
 - 1. "Sure Klean Weather Seal Blok-Guard & Graffiti Control II" Manufactured by Prosoco or Architect's approved equal. Install per manufacturer's recommendations.
- D. Concrete Site Flatwork (including sidewalks driveways, etc.)
 - 1. ConcreteSealers USA - PS101 Siliconate Multi-Surface (Smooth) WB Penetrating Sealer

3.7 INTERIOR PAINT SCHEDULE

- A. Concrete Masonry Units: Provide the following finish system over interior concrete masonry block units scheduled to receive paint or a comparable one from one of the approved manufacturers.
1. Satin Finish — Low Odor Zero VOC Topcoat
 - Primer:** PrepRite Block Filler, B25W25, <50 g/L VOC
 - 1st coat:** ProMar 200 Zero VOC Eg-Shel B26-2600 series, 0 g/L VOC
 - 2nd coat:** ProMar 200 Zero VOC Eg-Shel B26-2600 series, 0 g/L VOC
 2. Semi-Gloss Finish — Water-Based Epoxy System
 - Primer:** Loxon Block Surfacers, A24W200, <100 g/L VOC
 - 1st coat:** Pro Industrial Pre-Catalyzed Water-Based Epoxy Eg-Shel, K45 series, <150 g/L VOC
 - 2nd coat:** Pro Industrial Pre-Catalyzed Water-Based Epoxy Eg-Shel, K45 series, <150 g/L VOC
- B. Gypsum Board: Provide the following finish systems over interior gypsum board surfaces or a comparable one from one of the approved manufacturers:
1. Satin Finish — Low Odor Zero VOC System
 - Primer:** ProMar 200 Zero VOC Interior Latex Primer, B28W2600 0 g/L VOC
 - 1st coat:** ProMar 200 Zero VOC Eg-Shel B26-2600 series, 0 g/L VOC
 - 2nd coat:** ProMar 200 Zero VOC Eg-Shel B26-2600 series, 0 g/L VOC
 2. Semi-Gloss Finish - Water-Based Epoxy System
 - Primer:** ProMar 200 Zero VOC Primer, B28W2600, 0 g/L VOC
 - 1st coat:** Pro Industrial Pre-Catalyzed Water-Based Epoxy Semi-Gloss, K46 series, <150 g/L VOC
 - 2nd coat:** Pro Industrial Pre-Catalyzed Water-Based Epoxy Semi-Gloss, K46 series, <150 g/L VOC
- C. Woodwork and Hardboard (Stained Doors, Frames, Trim and Chair Rails): Provide the following finish systems over new, interior wood surfaces or a comparable one from one of the approved manufacturers:
1. Wood — Stained Doors, Frames, Trim and Chair Rails
 - Stain:** Wood Classics 250 g/l Stain, A49W800 series, 250 g/L VOC
 - 2nd coat:** Wood Classics WB Polyurethane A68, <350 g/L VOC
 - 3rd coat:** Wood Classics WB Polyurethane A68, <350 g/L VOC
- D. Non-Ferrous Metal & Ferrous Metal (Doors, Frames and Miscellaneous Metals): Provide the following finish systems over new, interior wood surfaces or a comparable one from one of the approved manufacturers:
1. Semi-Gloss Finish
 - Primer:** Pro Industrial Pro-Cryl Universal Primer, B66-310 series, <100 g/L VOC
 - 1st coat:** Pro Industrial Zero VOC Acrylic Semi-Gloss, B66-650 series, 0 g/L VOC
 - 2nd coat:** Pro Industrial Zero VOC Acrylic Semi-Gloss, B66-650 series, 0 g/L VOC
- E. Non-Ferrous Metal & Ferrous Metal (High Performance System for Handrails): Provide the following finish systems over new, interior wood surfaces or a comparable one from one of the approved manufacturers:
1. Egg-Shell or Semi-Gloss Finish
 - Primer:** Pro Industrial Pro-Cryl Universal Primer, B66-310 series, <100 g/L VOC
 - 1st coat:** Pro Industrial Zero VOC Water-Based Epoxy Eg-Shel, B73-360 series or Gloss, B73-300 series, 0 g/L VOC
 - 2nd coat:** Pro Industrial Zero VOC Water-Based Epoxy Eg-Shel, B73-360 series or Gloss, B73-300 series, 0 g/L VOC

- F. Galvanized Metal Decking & Ferrous Decking — Including Bar Joists: Provide the following finish systems over new, interior wood surfaces or a comparable one from one of the approved manufacturers:
1. **Flat, Egg-Shell**
 - Primer:** Pro Industrial Pro-Cryl Universal Primer, B66-310 series, <100 g/L VOC
 - 1st coat:** Low VOC Waterborne Acrylic Dryfall, Flat B42W81, Eg-Shel B42W82, Semi-Gloss, B42W83,
All sheens <50 g/L VOC

 - 2nd coat:** Low VOC Waterborne Acrylic Dryfall, Flat B42W81, Eg-Shel B42W82, Semi-Gloss, B42W83,
All sheens <50 g/L VOC
- G. Concrete Slabs with Opaque Sealers (Floors not scheduled for applied finishes)
1st and 2nd Coat: Benjamin Moore Floor Enamel C112 or Sherwin Williams – Porch and Floor Enamel.
- H. Provide the following systems for all exposed interior concrete masonry units not required to be painted:
1. Masonry (Concrete Masonry Units)
 - a. 1st/2nd Base Coat: Tex-Cote Graffiti Gard Ty-Cote (Clear)
Apply minimum two (2) coats at rate as recommended by Manufacturer, but not less than 175 to 200 sq. ft. per gallon per coat.
 - b. 3rd/4th Sealer Coat: Tex-Cote Graffiti Gard IIS System
Apply two uniform pinhole free, continuous flood coats (apply at rate of 175-200 Sq. Ft. Per Gallon over masonry block or 250-300 Sq. Ft. Per Gallon over masonry brick) over entire surface. Runs or sags shall be immediately brushed out to even the coat.

END OF SECTION 099000

SECTION 10 2800 - TOILET AND BATH ACCESSORIES

PART 1 - GENERAL

1.1 RELATED DOCUMENTS

- A. Drawings and general provisions of the Contract, including General and Supplementary Conditions and Division 1 Specification Sections, apply to this Section.

1.2 SUMMARY

- A. This Section includes the following:
 - 1. Toilet and bath accessories.

1.3 SUBMITTALS

- A. Product Data: Include construction details, material descriptions and thicknesses, dimensions, profiles, fastening and mounting methods, specified options, and finishes for each type of accessory specified.

1.4 QUALITY ASSURANCE

- A. Product Options: Accessory requirements, including those for materials, finishes, dimensions, capacities, and performance, are established by specific products indicated in the Toilet and Bath Accessory Schedule.
 - 1. Products of other manufacturers listed in Part 2 with equal characteristics, as judged solely by Architect, may be provided.

1.5 COORDINATION

- A. Coordinate accessory locations with other work to prevent interference with clearances required for access by disabled persons, proper installation, adjustment, operation, cleaning, and servicing of accessories.
- B. Deliver inserts and anchoring devices set into concrete or masonry as required to prevent delaying the Work.

PART 2 - PRODUCTS

2.1 MANUFACTURERS

- A. Manufacturers: Subject to compliance with requirements, provide accessories by one of the following:
 - 1. Toilet and Bath Accessories:
 - a. A & J Washroom Accessories, Inc.
 - b. American Specialties, Inc.
 - c. Bobrick Washroom Equipment, Inc.

- d. Bradley Corporation.
- e. Gamco.
- f. McKinney/Parker Washroom Accessories Corp.

2.2 MATERIALS

- A. Stainless Steel: ASTM A 666, Type 304, with No. 4 finish (satin), in 0.0312-inch minimum nominal thickness, unless otherwise indicated.
- B. Brass: ASTM B 19, leaded and unleaded flat products; ASTM B 16, rods, shapes, forgings, and flat products with finished edges; ASTM B 30, castings.
- C. Chromium Plating: ASTM B 456, Service Condition Number SC 2 (moderate service), nickel plus chromium electrodeposited on base metal.
- D. Mirror Glass: ASTM C 1036, Type I, Class 1, Quality q2, nominal 6.0 mm thick, with silvering, electroplated copper coating, and protective organic coating complying with FS DD-M-411.
- E. Galvanized Steel Mounting Devices: ASTM A 153/A 153M, hot-dip galvanized after fabrication.
- F. Fasteners: Screws, bolts, and other devices of same material as accessory unit, tamper and theft resistant when exposed, and of galvanized steel when concealed.

2.3 FABRICATION

- A. General: One, maximum 1-1/2-inch-diameter, unobtrusive stamped manufacturer logo, as approved by Architect, is permitted on exposed face of accessories. On interior surface not exposed to view or back surface of each accessory, provide printed, waterproof label or stamped nameplate indicating manufacturer's name and product model number.
- B. General: Names or labels are not permitted on exposed faces of accessories. On interior surface not exposed to view or on back surface of each accessory, provide printed, waterproof label or stamped nameplate indicating manufacturer's name and product model number.
- C. Surface-Mounted Toilet Accessories: Unless otherwise indicated, fabricate units with tight seams and joints, and exposed edges rolled. Hang doors and access panels with continuous stainless-steel hinge. Provide concealed anchorage where possible.
- D. Framed Glass-Mirror Units: Fabricate frames for glass-mirror units to accommodate glass edge protection material. Provide mirror backing and support system that permits rigid, tamper-resistant glass installation and prevents moisture accumulation.
- E. Mirror-Unit Hangers: Provide mirror-unit mounting system that permits rigid, tamper- and theft-resistant installation, as follows:
 - 1. One-piece, galvanized steel, wall-hanger device with spring-action locking mechanism to hold mirror unit in position with no exposed screws or bolts.

- F. Keys: Provide universal keys for internal access to accessories for servicing and resupplying. Provide minimum of six keys to Owner's representative.

PART 3 - EXECUTION

3.1 INSTALLATION

- A. Install accessories according to manufacturers' written instructions, using fasteners appropriate to substrate indicated and recommended by unit manufacturer. Install units level, plumb, and firmly anchored in locations and at heights indicated.
- B. Secure mirrors to walls in concealed, tamper-resistant manner with special hangers, toggle bolts, or screws. Set units level, plumb, and square at locations indicated, according to manufacturer's written instructions for substrate indicated.
- C. Install grab bars to withstand a downward load of at least 250 lbf, when tested according to method in ASTM F 446.

3.2 ADJUSTING AND CLEANING

- A. Adjust accessories for unencumbered, smooth operation and verify that mechanisms function properly. Replace damaged or defective items.
- B. Remove temporary labels and protective coatings.
- C. Clean and polish exposed surfaces according to manufacturer's written recommendations.

3.3 TOILET AND BATH ACCESSORY SCHEDULE

- A. Accessory items are based on Bobrick product numbers unless otherwise noted.
- B. Paper Towel Dispenser: Owner furnished, contractor installed.
- C. Toilet Tissue Dispenser: Owner furnished, contractor installed.
- D. Grab Bar: Provide stainless-steel grab bar complying with the following:
 - 1. Products: Bobrick; B-5806, 18", 36" & 42" & shower grab bar.
 - 2. Stainless-Steel Nominal Thickness: Minimum 0.05 inch. Mounting: Concealed with manufacturer's standard flanges and anchors.
 - 3. Gripping Surfaces: Smooth, satin finish.
 - 4. Outside Diameter: 1-1/4 inches for medium-duty applications.
- E. Mirror Unit: Provide mirror unit complying with the following:
 - 1. Products: Bobrick; B-165, 24"X48" and other size as indicated on drawings.
 - 2. Stainless-Steel, Channel-Framed Mirror: Fabricate frame from stainless-steel channels in manufacturer's standard satin or bright finish with square corners mitered to hairline joints and mechanically interlocked.
- F. Soap Dispenser: Owner furnished, contractor installed.

- G. Mop Rack:
 - 1. Products: Bobrick; B-223, 36" surface mounted.
- H. Sanitary Napkin Disposal: Owner furnished, contractor installed.
- I. Folding Shower Seat:
 - 1. Products: Bobrick B-5191
- J. Shower Curtain:
 - 1. Products: Bobrick 204-2
- K. Towel Bar:
 - 1. Products: Bobrick B-76737

END OF SECTION 10 2800

SECTION 10 5113 - METAL LOCKERS

PART 1 - GENERAL

1.1 RELATED DOCUMENTS

- A. Drawings and general provisions of the Contract, including General and Supplementary Conditions and Division 1 Specification Sections, apply to this Section.

1.2 SUMMARY

- A. This Section includes the following:
 - 1. Wardrobe lockers, including the following:
 - a. Single tier (In Locker Room)
 - b. Accessible Lockers (At locations shown on drawings or not less than 5% of total units installed).

1.3 SUBMITTALS

- A. Product Data: Include construction details, material descriptions, dimensions of individual components and profiles, and finishes for each type of locker and bench.
- B. Shop Drawings: Include plans, elevations, sections, details, and attachments to other Work.
 - 1. Show locker fillers, trim, base, sloping tops, and accessories. Include locker-numbering sequence.
- C. Samples for Initial Selection: Manufacturer's color charts showing the full range of colors available for units with factory-applied color finishes.

1.4 QUALITY ASSURANCE

- A. Source Limitations: Obtain locker units and accessories through one source from a single manufacturer.

1.5 CLOSEOUT SUBMITTALS

- A. Maintenance Data: For adjusting, repairing, and replacing locker doors and latching mechanisms to include in maintenance manuals.

1.6 MAINTENANCE MATERIAL SUBMITTALS

- A. Furnish extra materials that match products installed and that are packaged with protective covering for storage and identified with labels describing contents.
 - 1. The following metal locker hardware items equal to 10 percent of amount installed for each type and finish installed, but no fewer than five units:

- a. Locks.
- b. Blank identification plates.
- c. Hooks.

1.7 DELIVERY, STORAGE, AND HANDLING

- A. Do not deliver lockers until spaces to receive them are clean, dry, and ready for locker installation.
- B. Protect lockers from damage during delivery, handling, storage, and installation.

PART 2 - PRODUCTS

2.1 MANUFACTURERS

- A. Manufacturer: Subject to compliance with requirements, provide products by one of the following:
 1. Art Metal Products; Div. of Fort Knox Storage Co.
 2. Interior/Medart.
 3. Lyon Metal Products, Inc.
 4. Penco Products, Inc.; Subsidiary of Vesper Corporation.
 5. Republic Storage Systems Co., Inc.
 6. Tensco Corporation.
 7. WEC Manufacturing
 8. Hadrian Manufacturing, Inc.

2.2 MATERIALS

- A. Cold-Rolled Steel Sheet: ASTM A 366/A 366M, matte finish, suitable for exposed applications, and stretcher leveled or roller leveled to stretcher-leveled flatness.
- B. Fasteners: Zinc- or nickel-plated steel, slotless-type exposed bolt heads, and self-locking nuts or lock washers for nuts on moving parts.

2.3 WARDROBE LOCKERS

- A. Body: Form backs, tops, bottoms, sides, and intermediate partitions from steel sheet; flanged for double thickness at back vertical corners. Comply with the following:
 1. Back-Material Sheet Thickness: 0.0239 inch.
 2. Side-Material Sheet Thickness: 0.0239 inch.
 3. Exposed Ends: Form exposed ends of nonrecessed lockers from minimum 0.0598-inch- thick steel sheet.
- B. Frames: Form channel frames from minimum 0.0598-inch- thick steel sheet; lapped and welded at corners. Form continuous integral door strike on vertical frame members. Provide resilient bumpers to cushion door closing.
 1. Latch Hooks: Form from minimum 0.1046-inch- thick steel; welded or riveted to door frames.

- C. Doors: One-piece steel sheet, formed into channel shape at vertical edges and flanged at right angles at top and bottom edges. Fabricate to prevent springing when opening or closing, and to swing 180 degrees. Comply with the following:
 - 1. Sheet Thickness: 0.0598 inch minimum.
 - 2. Reinforcing and Sound-Dampening Panels: Brace or reinforce inner face of doors with manufacturer's standard reinforcing angles, channels, or stiffener panels.
 - 3. Louvered Vents: Stamped, louvered vents in door face, as follows:
 - a. Double-Tier Lockers: No fewer than three louver openings at top and bottom.
- D. Shelves: Provide hat shelf in single-tier units; fabricated from minimum 0.0239-inch- thick, formed steel sheet; flanged on all edges.
- E. Hinges: Steel, full loop, five or seven knuckle; tight pin; minimum 2 inches high. Weld to inside of door frame and attach to door with at least two factory-installed fasteners that are completely concealed and tamper resistant when door is closed.
 - 1. Provide at least three hinges for each door more than 42 inches high and at least two hinges for each door 42 inches high or less.
- F. Projecting Handle and Latch: Manufacturer's standard, positive automatic, prelocking, pry-resistant latch and pull; chromium-plated, heavy-duty, vandal-resistant, lift-up handle, as follows:
 - 1. Provide minimum three-point latching for each door more than 42 inches high; minimum two-point latching for each door 42 inches high or less.

2.4 LOCKS

- A. Fabricate lockers to receive the following locking devices, installed on lockers using security-type fasteners:
 - 1. Built-in Combination Locks: Key-controlled, three-number dialing combination locks; capable of at least five combination changes made automatically with a control key.

2.5 LOCKER ACCESSORIES

- A. Interior Equipment: Furnish each locker with the following items, unless otherwise indicated:
 - 1. Hooks: Manufacturer's standard zinc-plated, ball-pointed steel. Provide one double-prong ceiling hook, and not fewer than two single-prong wall hooks for single-, double-, and triple-tier units. Attach hooks with at least two fasteners.
- B. Number Plates: Manufacturer's standard etched, embossed, or stamped, aluminum number plates with numerals at least 3/8 inch high. Number lockers in sequence indicated. Attach plates to each locker door, near top, centered, with at least two aluminum rivets.
- C. Continuously Sloping Tops: Manufacturer's standard, fabricated from minimum 0.0359-inch- thick steel sheet, for installation over lockers with separate flat tops. Fabricate tops in lengths as long as practicable, without visible fasteners at splice locations, finished to match lockers. Provide fasteners, filler plates, supports, and closures, as follows:
 - 1. Closures: Hipped-end type.

2.6 FABRICATION

- A. Unit Principle: Fabricate each locker with an individual door and frame, individual top, bottom, back, and shelves, and common intermediate uprights separating compartments.
- B. Fabricate lockers square, rigid, and without warp, with metal faces flat and free of dents or distortion. Make exposed metal edges free of sharp edges and burrs, and safe to touch. Weld frame members together to form a rigid, one-piece assembly.

2.7 FINISHES, GENERAL

- A. Finish all steel surfaces and accessories, except prefinished stainless steel and chrome-plated surfaces.
- B. Comply with NAAMM's "Metal Finishes Manual for Architectural and Metal Products" for recommendations for applying and designating finishes.

2.8 STEEL SHEET FINISHES

- A. Surface Preparation: Clean surfaces of dirt, oil, grease, mill scale, rust, and other contaminants that could impair paint bond. Use manufacturer's standard methods.
- B. Baked-Enamel Finish: Immediately after cleaning and pretreating, apply manufacturer's standard baked-enamel finish consisting of a thermosetting topcoat. Comply with paint manufacturer's written instructions for applying and baking to achieve a minimum dry film thickness of 1.4 mils on doors, frames, and legs, and 1.1 mils elsewhere.
 - 1. Color and Gloss: As selected by Architect from manufacturer's full range.

PART 3 - EXECUTION

3.1 INSTALLATION

- A. Install metal lockers and accessories level, plumb, rigid, and flush according to manufacturer's written instructions.
- B. Anchor lockers to floors and walls at intervals recommended by manufacturer, but not more than 36 inches o.c. Install anchors through backup reinforcing plates where necessary to avoid metal distortion, using concealed fasteners.
- C. Fit exposed connections of trim, fillers, and closures accurately together to form tight, hairline joints, with concealed fasteners and splice plates.
 - 1. Attach sloping top units to lockers, with closures at exposed ends.
- D. Attach finished end panels with fasteners only at perimeter to conceal exposed ends of nonrecessed lockers.

3.2 ADJUSTING, CLEANING, AND PROTECTION

- A. Adjust doors and latches to operate easily without binding. Verify that integral locking devices operate properly.
- B. Clean interior and exposed exterior surfaces and polish stainless-steel and nonferrous-metal surfaces.
- C. Protect lockers from damage, abuse, dust, dirt, stain, or paint. Do not permit locker use during construction.
- D. Touch up marred finishes, or replace locker units that cannot be restored to factory-finished appearance. Use only materials and procedures recommended or furnished by locker manufacturer.

END OF SECTION 10 5113

SECTION 12 3661.16 - SOLID SURFACING COUNTERTOPS

PART 1 - GENERAL

1.1 RELATED DOCUMENTS

- A. Drawings and general provisions of the Contract, including General and Supplementary Conditions and Division 01 Specification Sections, apply to this Section.

1.2 SUMMARY

- A. Section Includes:
 - 1. Solid surface material countertops.
 - 2. Solid surface material backsplashes.
 - 3. Solid surface material end splashes.
 - 4. Solid surface material apron fronts.
 - 5. Solid surface material sinks.

1.3 ACTION SUBMITTALS

- A. Product Data: For countertop materials and sinks.
- B. Shop Drawings: For countertops. Show materials, finishes, edge and backsplash profiles, methods of joining, and cutouts for plumbing fixtures.
 - 1. Show locations and details of joints.
 - 2. Show direction of directional pattern, if any.
- C. Samples for Initial Selection: For each type of material exposed to view.
- D. Samples for Verification: For the following products:
 - 1. Countertop material, 6 inches square.
 - 2. Wood trim, 8 inches long.
 - 3. One full-size solid surface material countertop, with front edge and backsplash, 8 by 10 inches, of construction and in configuration specified.

1.4 INFORMATIONAL SUBMITTALS

- A. Qualification Data: For fabricator.

1.5 CLOSEOUT SUBMITTALS

- A. Maintenance Data: For solid surface material countertops to include in maintenance manuals. Include Product Data for care products used or recommended by Installer and names, addresses, and telephone numbers of local sources for products.

1.6 QUALITY ASSURANCE

- A. Fabricator Qualifications: Shop that employs skilled workers who custom-fabricate countertops similar to that required for this Project, and whose products have a record of successful in-service performance.
- B. Installer Qualifications: Fabricator of countertops.
- C. Mockups: Build mockups to demonstrate aesthetic effects and to set quality standards for fabrication and execution.
 - 1. Build mockup of typical countertop as shown on Drawings.
 - 2. Subject to compliance with requirements, approved mockups may become part of the completed Work if undisturbed at time of Substantial Completion.

1.7 FIELD CONDITIONS

- A. Field Measurements: Verify dimensions of countertops by field measurements after base cabinets are installed but before countertop fabrication is complete.

1.8 COORDINATION

- A. Coordinate locations of utilities that will penetrate countertops or backsplashes.

PART 2 - PRODUCTS

2.1 SOLID SURFACE COUNTERTOP MATERIALS

- A. Solid Surface Material: Homogeneous-filled plastic resin complying with ICPA SS-1.
 - 1. Manufacturers: Subject to compliance with requirements, provide products by one of the following:
 - a. Avonite Surfaces.
 - b. E. I. du Pont de Nemours and Company.
 - c. Formica Corporation.
 - d. LG Chemical, Ltd.
 - e. Samsung Chemical USA, Inc.
 - f. Wilsonart LLC.
 - 2. Type: Provide Standard type unless Special Purpose type is indicated.
 - 3. Integral Sink Bowls: Comply with CSA B45.5/IAPMO Z124.
 - 4. Colors and Patterns: As selected by Architect from manufacturer's full range.

- B. Particleboard: ANSI A208.1, Grade M-2-Exterior Glue.
- C. Plywood: Exterior softwood plywood complying with DOC PS 1, Grade C-C Plugged, touch sanded.

2.2 COUNTERTOP FABRICATION

- A. Fabricate countertops according to solid surface material manufacturer's written instructions and to the AWI/AWMAC/WI's "Architectural Woodwork Standards."
 - 1. Grade: Premium.
- B. Configuration:
 - 1. Front: Straight, slightly eased at top
 - 2. Backsplash: Straight, slightly eased at corner.
 - 3. End Splash: Matching backsplash.
- C. Countertops: 3/4-inch thick, solid surface material with front edge built up with same material.
- D. Backsplashes: 3/4-inch thick, solid surface material.
- E. Fabricate tops with shop-applied edges and backsplashes unless otherwise indicated. Comply with solid surface material manufacturer's written instructions for adhesives, sealers, fabrication, and finishing.
 - 1. Fabricate with loose backsplashes for field assembly.
 - 2. Install integral sink bowls in countertops in the shop.
- F. Joints: Fabricate countertops without joints.
- G. Cutouts and Holes:
 - 1. Undercounter Plumbing Fixtures: Make cutouts for fixtures in shop using template or pattern furnished by fixture manufacturer. Form cutouts to smooth, even curves.
 - a. Provide vertical edges, slightly eased at juncture of cutout edges with top and bottom surfaces of countertop and projecting 3/16 inch into fixture opening.
 - b. Provide vertical edges, rounded to 3/8-inch radius at juncture of cutout edges with top surface of countertop, slightly eased at bottom, and projecting 3/16 inch into fixture opening.
 - c. Provide 3/4-inch full bullnose edges projecting 3/8 inch into fixture opening.
 - 2. Counter-Mounted Plumbing Fixtures: Prepare countertops in shop for field cutting openings for counter-mounted fixtures. Mark tops for cutouts and drill holes at corners of cutout locations. Make corner holes of largest radius practical.
 - 3. Fittings: Drill countertops in shop for plumbing fittings, undercounter soap dispensers, and similar items.

4. Counter-Mounted Cooktops: Prepare countertops in shop for field cutting openings for cooktops. Mark tops for cutouts and drill holes at corners of cutout locations. Make corner holes of largest radius practical.

2.3 INSTALLATION MATERIALS

- A. Adhesive: Product recommended by solid surface material manufacturer.
- B. Sealant for Countertops: Comply with applicable requirements in Section 07 9200 "Joint Sealants."

PART 3 - EXECUTION

3.1 EXAMINATION

- A. Examine substrates to receive solid surface material countertops and conditions under which countertops will be installed, with Installer present, for compliance with requirements for installation tolerances and other conditions affecting performance of countertops.
- B. Proceed with installation only after unsatisfactory conditions have been corrected.

3.2 INSTALLATION

- A. Install countertops level to a tolerance of 1/8 inch in 8 feet, 1/4 inch maximum. Do not exceed 1/64-inch difference between planes of adjacent units.
- B. Fasten countertops by screwing through corner blocks of base units into underside of countertop. Pre-drill holes for screws as recommended by manufacturer. Align adjacent surfaces and, using adhesive in color to match countertop, form seams to comply with manufacturer's written instructions. Carefully dress joints smooth, remove surface scratches, and clean entire surface.
- C. Fasten subtops to cabinets by screwing through subtops into cornerblocks of base cabinets. Shim as needed to align subtops in a level plane.
- D. Secure countertops to subtops with adhesive according to solid surface material manufacturer's written instructions. Align adjacent surfaces and, using adhesive in color to match countertop, form seams to comply with manufacturer's written instructions. Carefully dress joints smooth, remove surface scratches, and clean entire surface.
- E. Bond joints with adhesive and draw tight as countertops are set. Mask areas of countertops adjacent to joints to prevent adhesive smears.
 1. Install metal splines in kerfs in countertop edges at joints where indicated. Fill kerfs with adhesive before inserting splines and remove excess immediately after adjoining units are drawn into position.
 2. Clamp units to temporary bracing, supports, or each other to ensure that countertops are properly aligned and joints are of specified width.

- F. Install backsplashes and end splashes by adhering to wall and countertops with adhesive. Mask areas of countertops and splashes adjacent to joints to prevent adhesive smears.
- G. Install aprons to backing and countertops with adhesive. Mask areas of countertops and splashes adjacent to joints to prevent adhesive smears. Fasten by screwing through backing. Pre-drill holes for screws as recommended by manufacturer.
- H. Complete cutouts not finished in shop. Mask areas of countertops adjacent to cutouts to prevent damage while cutting. Make cutouts to accurately fit items to be installed, and at right angles to finished surfaces unless beveling is required for clearance. Ease edges slightly to prevent snipping.
 - 1. Seal edges of cutouts in particleboard subtops by saturating with varnish.
- I. Apply sealant to gaps at walls; comply with Section 07 9200 "Joint Sealants."

END OF SECTION 12 3661.16

SECTION 11400 – FOOD SERVICE EQUIPMENT**PART 1 - GENERAL****1.1 DESCRIPTION OF WORK**

- A. The extent of Food Service Equipment is shown on the drawings and by schedules and equipment lists.

1.2 RELATED DOCUMENTS

- A. Drawings and general provisions of the contract documents, including General and Supplementary Conditions and Division 1- Specification sections apply to work of this section.
- B. Bidder is responsible for information and requirements located and identified on every part of the contract plans and specifications.
- C. Mechanical and Electrical Work: Refer to this project's specification sections Division 15 and Division 16, respectively, for mechanical and electrical services and connections for individual items of Food Service Equipment.

1.3 QUALITY ASSURANCE

- A. Standards:
 - 1. Except as otherwise indicated, comply with the following standards as applicable to the manufacture, fabrication and installation of the work of this section:
 - 2. NSF Standards: Comply with National Sanitation Foundation standards and criteria, and provide NSF "Seal of Approval" on each manufactured item and on major items of custom-fabricated work.
 - 3. UL Standards: For electrical components and assemblies provide either UL labeled products or, where no labeling service is available, "recognized markings" to indicate listing in the UL "Recognized Component Index".
 - 4. ANSI Standards: For gas-burning equipment. Comply with ANSI Z21-Series standard and provide labels indicating name of testing agency. Comply with ANSI B57.1 for compressed Gas Association for compressed gas piping. Comply with ANSI A40.4 and A40.6 for water connection air gaps and vacuum breakers.
 - 5. NFPA Standards: Comply with NFPA No. 96 for exhaust systems.
 - 6. BISSC Certified: For bakery equipment
 - 7. ASME Code: Comply with ASME Boiler code requirements for steam generating and steam heated equipment; provide ASME inspection stamp and registration with National Board.
 - 8. National Electrical Code: comply with NFPA Volume 5 for electrical wiring and devices included with Food Service Equipment, ANSI C2 and C73, and applicable NEMA and NECA standards.
 - 9. Seismic Restraints: Complies with SMACNA's details.
- B. Manufactured Products; Fabrication: Provide standard or custom manufactured products to comply with requirements; otherwise, shop fabricate the work to the greatest extent possible, in shops which are skilled and experienced with a minimum of three years experience in the production of Food Service equipment.

1.4 SUBMITTALS

A. Production Data:

1. Submit (1) complete electronic set, prior to ordering and/or fabrication, of manufacturer's or shop fabricator's product information and installation instructions for each item of Food Service Equipment. For operating equipment include data on performance and operating characteristics, power/fuel consumption, rough-in dimensions and sizes, drainage requirements and similar information.
2. Submit (1) complete electronic set and (3) three sets of bound maintenance manuals, operating instructions, spare parts list, precautions against hazards, manufacturer's warranties and similar information. Distribute an additional copy of installation and start-up instructions to the installer. Mark each data sheet or brochure with the project name and applicable project equipment number(s).

B. Shop Drawings

1. Submit (1) complete electronic set of documents, prior to ordering and/or fabrication, of shop drawings showing layouts, elevations, sections and details of custom fabricated work (work not shown by manufacturer's standard product data sheets). Show plan layouts at 1/4" scale, elevations at 1/2" scale and details at 1 1/2" or larger scales, as required.

C. Samples

1. Submit (3) samples of each exposed finish on shop-fabricated and field-fabricated Food Service Equipment. Submit 12" squares of sheet materials and 24" lengths of linear materials. Architect for color, pattern, and texture will review samples; compliance with other requirements is the exclusive responsibility of the contractor.

1.5 PRODUCT HANDLING

- A. Protect metal finishes from damage during shipping, storage, handling, installation and construction of other work in the same space. Wrap and crate each item of equipment as needed for protection from damage. Covers exposed stainless steel surfaces with self-adhesive protective paper, of a type recommended by the metal manufacturer, and do not remove until work is installed and ready for cleaning and start-up.

PART 2 - PRODUCTS

2.1 MATERIALS

A. Metals:

1. Stainless Steel (S/S): AISI Type 302/304, hardest workable temper, No. 4 directional polish.
2. Galvanized Steel Sheet (G.I.): ASTM A526, except ASTM A527 for extensive forming; ASTM A525, G90 zinc coating, chemical treatment. Where painted finish is indicated, provide mill-phosphatized treatment in lieu of chemical treatment.
3. Steel Sheet: ASTM A 569 hot-rolled carbon steel.
4. Galvanized Steel Pipe: ASTM A53 or ASTM A120, welded or seamless, schedule 40, galvanized.

5. Steel Structure Members: Hot rolled or cold formed, carbon steel unless stainless is indicated.
 6. Galvanized Finish (G.I): ASTM A123 hot-dipped zinc coating applied after fabrication.
 7. Aluminum: ASTM B209/B221 sheet, plate and extrusions (as indicated); alloy, temper and finish as determined by manufacturer/fabricator, except 0.40-mil natural anodized finish on exposed work unless another finish is indicated.
- B. Plastic Laminate:
1. NEMA LD3, Type 2, 0.051" thick, except Type 3, 0.042" for post-forming smooth (non-texture) white unless another texture and color is indicated or selected by Architect. Comply with NSF No. 35 where applicable.
- C. Hardwood Work Surfaces:
1. Laminated edge-grained hard maple (*Acer saccharum*), NHLA First Grade with Knots, holes and other blemishes culled out, kiln dried at 8% or less moisture, waterproof glue, machined, sanded, and finished with NSF approved oil-sealer.
- D. Insulation:
1. Cooled Component Insulation: Rigid, closed-cell polyurethane foam; either heat-aged slab stock for adhesive lamination with face sheets, or foamed in place using Freon 11 as expanding agent; k-value of 0.15; not less than 1.7 lbs. Per cu ft. density.
 2. Heated-Component Insulation: Rigid board, semi-rigid blanket or adhesive applied blanket of glass fiber or other mineral fiber insulation, certified by manufacturer to withstand long-term exposure to heat (temperature rating of each insulated equipment item) without deterioration. K-value of not more than 0.30; density of not less than 1.5 lbs. Per cu. Ft.
- E. Joint Materials:
1. Sealant: 1-part or 2-part, polyurethane or silicone based, liquid elastomeric sealant, non-solvent release type, Shore A hardness of 30 except 45 if subject to traffic.
 2. Backer Rod: Polyurethane rod stock, larger than joint width.
 3. Gaskets: Solid or hollow (but not cellular) neoprene or polyvinyl chloride; light gray, minimum of 40 Shore A hardness, self-adhesive or prepared for either adhesive application or mechanical anchorage.
- F. Paint and Coatings:
1. Provide the types of painting and coating materials which, after drying or curing are suitable for use in conjunction with foodservice, and which are durable, non-toxic, non-dusting, non-flaking, mildew resistant, and comply with governing regulations for Food Service.
- G. Sound Deadening:
1. Heavy-bodied resinous coating, filled with granulated cork or other resilient material, compounded for permanent, non-flaking adhesion to metal in a 1/8" thick coating.
 - a. Galvanized Repair Paint: MIL-P-21035.
 - b. Pretreatment: SSPC-PT2 or PT3, or FT C490.
 2. Primer Coating for Metal: FS TT-P-86 type suitable for baking where indicated.
 3. Enamel for Metal: Synthetic types, FS TT-P-491, type suitable for baking where indicated.

2.2 FABRICATED PRODUCTS

A. Hardware:

1. General: Manufacturer's standard, but not less than ANSI 156.9 Type 2 (Institutional), satin finish stainless steel or dull chrome finish on brass, bronze or steel.
 - a. Cabinet Catches: Heavy-duty magnetic type, except as otherwise indicated.
 - b. Drawer Slides: Ball bearing type, side-mounting, self-closing, 250 lb. capacity.
 - c. Sliding Door Hardware: Overhead track with tandem nylon wheel hangers for door leaves over 5 sq. ft. area; roller less sanitary slides for smaller doors (comply with NSF standards).

B. Casters:

1. Type and size as recommended by caster manufacturer, NSF approved, for the type and weight of equipment supported; but not less than 4" diameter with 15/16" tread width, with sealed self-lubricating ball bearings, cadmium-plated steel disc wheels and solid light-gray synthetic rubber tires. Provide stainless steel horns and accessories. Unless otherwise indicated, equip each item with 2 swivel-type casters and 2 fixed casters, and provide foot brakes on 2 casters on opposite corners of equipment.
 - a. Caster Bumpers: Unless equipment item is equipped with another form of all-around protective bumper provide circular rotating bumper above each caster, 5" diameter tire of light gray synthetic rubber (hollow or closed-cell) on cadmium-plated disc.

C. Plumbing Fittings, Trim and Accessories:

1. General: Where exposed or semi-exposed, provide bright chrome-plated brass or polished stainless steel units. Provide copper or brass where not exposed.

D. Water Outlets:

1. Water Fill Devices: At sinks and at other locations where water is supplied (by manual, automatic or remote control), provide commercial quality faucets, valves, dispensers or fill devices, of the type and size indicated, and as required to operate as indicated.
2. Vacuum Breakers: Provide with Food Service Equipment where specified/required.
3. Waste Fittings: Except as otherwise indicated, provide 2" remote-lever waste valves, and 3.5" strainer basket. Integrate unit for direct connection with waste grinder where indicated.
4. P-Traps: Include removable P-traps where drains are indicated for direct connection to drainage system.

E. Electrical Materials:

1. General: Provide standard materials, devices and components as recommended by the manufacturer/fabricator, selected and installed in accordance with NEMA standards and recommendations; and as required for safe and efficient use and operation of the Food Service Equipment without objectionable noise, vibration and sanitation problems.
 - a. Controls and Signals: Provide recognized and commercial grade signals, "on-off" push button or switches, and other speed and temperature controls as required for operation, complete with pilot lights and permanent signs and graphics to assist the user of each item. Provide stainless steel cover plates at control and signal electrical boxes.

- b. Connections: Equip each item requiring electrical power with either a terminal box for permanent connection or cord-and-plug for interruptible connection as indicated. Provide standard ground-type plugs, matching outlets (specified in Division 15), light gray (plug and cord)
- c. Motors: Totally enclosed type, except drip-proof type where not exposed to a dust or moisture condition; ball bearings, except sleeve bearings and small timing motors; windings impregnated to resist moisture; horse-power and duty-cycle ratings as required for the service indicated.
- d. Power Characteristics: Refer to Division 16 specifications for project power characteristics. Also, refer to individual equipment requirements for loads and ratings.

2.3 FABRICATION OF METALWORK

A. General Fabrication Requirements:

1. Remove burrs from sheared edges of metalwork, ease the corners and smooth to eliminate cutting hazard. Bend sheets of metal at not less than the minimum radius required avoiding grain-separation in the metal. Maintain flat, smooth surfaces without damage to finish. Reinforce metal at locations of hardware, anchorage and accessory attachments, wherever metal is less than 14 gage or requires mortise application. Conceal reinforcements to the greatest extent possible. Weld in place on concealed faces.
2. Where fasteners are permitted, provide Phillips head, flat or oval head machine screws. Cap threads with acorn nuts unless fully concealed in inaccessible construction, and provide nuts and lock washers unless metal for tapping is at least 12 gauge. Match fastener head finish with finish of metal fastened.
3. Provide removable panels for access to mechanical and electrical service connections that are concealed behind or within foodservice equipment, but only where access is not possible and not indicated through other work.

B. Metal and Gauges:

1. Except as otherwise indicated, fabricate exposed metalwork of stainless steel; fabricate the following components from the gauge of metal indicated, and other components from not less than 20-gauge metal:
 - a. Table tops, Counter tops, Sinks, Drain-boards: 14 Gauge.
 - b. Shelves: 16 gauge, 18 gauge if less than 12" wide.
 - c. Front Drawer/Door Panels: 18 gauge (double-pan type).
 - d. Single-Pan Doors and Drawer Fronts: 16 gauge
 - e. Enclosed Base Cabinets: 18 gauge
 - f. Enclosed Wall Cabinets: 18 gauge
 - g. Exhaust Hoods: 18 gauge
 - h. Pan Type Inserts and Trays: 16 gauge
 - i. Skirts and Enclosure Panels: 18 gauge
 - j. Closure and Trim strips over 4" wide: 18 gauge
 - k. Hardware Reinforcement: 12 gauge
 - l. Gusset Plates: 10 gauge

C. Work-Surface Fabrication:

1. Fabricate metal work surfaces by forming and welding to provide seamless construction, using welding rods matching sheet metal, grinding and polishing. Where necessary for disassembly, provide waterproof gaskets draw-type joints with concealed bolting.

2. Reinforce work-surfaces 30" o.c. both ways with galvanized or stainless concealed structural members, reinforce edges which are not self-reinforced by formed edges.
3. Sound deaden underside of metal work-surfaces, including sinks and similar units, with a coating of sound deadening material. Hold coating back 3" from sanitary edges that are open for cleaning.

D. Structural Framing:

1. Except as otherwise indicated, provide framing of minimum 1"-pipe-size round pipe or tube members, with mitered and welded joints and gusset plates, ground smooth. Provide 14 gauge stainless steel tube joints for exposed framing and galvanized steel pips for concealed framing.
2. Where indicated, flange rear and end edges up to form splashes integrally with top, with vertical and horizontal corners coved on not less than $\frac{1}{4}$ " radius, die formed. Turn back splashes 1" to wall across top and ends with rounded edge on break unless otherwise specified.
3. For die-crimped edges, use inverted "V" $\frac{1}{2}$ " deep inside and 2" deep on outside, unless otherwise shown. For straight down flanges, make 1 $\frac{3}{4}$ " deep on outside. For bull nose edges, roll down 1 $\frac{3}{4}$ ".
 - a. Edges: die-formed, integral with top. For rounded corners, form to 1" radius, weld, and polish to original finish.

E. Field Joints:

1. For any field joint required because of size of fixture, butt-joint, reinforce on underside with angles of same material, bolt together with non-corrosive bolts and nuts, field weld, grind and polish.

F. Pipe Bases:

1. Construct pipe bases of 1-5/8" diameter 18 gauge stainless steel tubing. Fit legs with polished stainless steel sanitary adjustable bullet feet to provide for adjustment of approximately 1 $\frac{1}{2}$ " without exposing threads.
2. Space legs to provide ample support for tops, preclude any possibility of buckling or sagging and in no case more than 6'-0" centers.

G. Shelves:

1. Construct solid shelves under pipe base tables of 16 gauge stainless steel, with 1 $\frac{1}{2}$ " turned down and under edges, and 2" turn up at rear, against walls, welded to pipe legs.

H. Sinks:

1. Construct sinks of 14 gauge stainless steel No. 4 finish inside and outside. Form back, bottom, front, of one piece with ends, partitions, welded into place.
2. Partitions: double thickness, 1" minimum space between walls.
3. Cove interior vertical and horizontal corners of each tub not less than $\frac{1}{4}$ " radius, die formed. Outside ends of drain boards to have roll rim risers not less than 2 $\frac{1}{2}$ " high.
4. Drill faucet holes in splashes 2 $\frac{1}{2}$ " below top edge on 8" centers.
5. Weld sinks set into drain boards by 1 $\frac{1}{2}$ " x 14 gauge stainless steel angle brackets, securely welded to sinks and galvanized cross angles spot welded to underside of drain boards.
6. Sink Drains: Install in center of bottom of each sink bowl 1 $\frac{1}{2}$ " I.P.S. quick opening pop-up lever type drain approximately 4" high, with a 4 $\frac{1}{2}$ " flange with lugs, and fit with 3-1/8" stainless steel strainer plate.

7. Lever Handle: Of sufficient length to extend to front of sink, threaded at one end and fitted with tension spring. No riveting, screws or soldering permitted to fit drains to sinks, with all parts of drains easily removable for servicing and replacement.
 8. Slope bottom of sink bowls toward outlet. Include chrome-plated tailpiece and trap.
- I. Workmanship:
1. Best quality in the trade. Field verify dimensions, check measurements before fabricating; conform all items to dimensions of building; neatly fit around pipes, offsets and other obstructions.
 2. Fabricate only in accordance with approved shop drawings, showing all pipes, obstructions to be built around, and location of Utility Requirements and services.
 3. After the General Contractor has approved Shop Drawings, he is responsible for preventing additional obstructions being placed in way of kitchen equipment.
 4. Where equipment is exposed to customer view, provide enclosure of service lines, operating components and mechanical and electrical devices.
- J. Enclosures:
1. Provide enclosures, including panels, housings and skirts for service lines, operating components and mechanical and electrical devices associated with the Food Service Equipment, except as specifically indicated to be "open".
- K. Casework:
1. At fabricator's option, and unless otherwise indicated, provide either box-type face framing or open-channel-type (complying with NSF requirements in either case).
 - a. Enclosure: Except as otherwise indicated, provide each unit of casework (base, wall, overhead and free-standing) with a complete enclosure metal cabinet, including fronts, backs, tops, bottoms, and sides.
 - b. Door and Drawer Fronts: Except where single-pan construction is indicated, provide double-pan type, not less than 5/8" thick, with seams on inside face. Weld hardware reinforcement inside of inner pan. Sound deaden by either coating both pans on concealed face, or inserting mineral wool insulation between pans.
 - c. Shelves: Except as otherwise indicated, provide adjustable standards for positioning and support of shelves in casework. Turn back-edge of shelf unit up 2" and hem. Turn other edges down to form open channel. Reinforce shelf units to support 40 lbs. per sq. ft. loading, plus 100% impact loading.
 - d. Drawer Bodies: Except as otherwise indicated, draw-form drawer bodies from a single piece of metal to provide seamless construction. Flange top edge to protect slides from spillage.
 - e. Closed Base: Where casework is indicated to be located on a raised-floor base, prepare casework for support without legs, and for anchorage and sealant application, as required for a completely enclosed and concealed base.
 - f. Support from Floor: Equip floor-supported mobile units with casters and equip items indicated as "roll-out" units with manufacturer's standard one-directional rollers. Otherwise, and except for closed-base units, provide pipe or tube legs, with adjustable bullet-design feet for floor-supported items of fabricated metalwork. Provide 1 1/2" adjustment of feet (concealed threading).
- L. Exhaust Hood Fabrication:
1. Comply with NFPA -96, including Appendix A.
 2. Grease Removal: Provide type indicated (removable filters if not otherwise indicated), with drip-channel gutters, drains and collection basing.

3. Light Fixtures: Fluorescent fixtures, UL listed for hoods with sealed safety lenses flush with inside of hood; stainless steel conduit for wiring/or UL listed for hoods, incandescent fixtures with sealed safety lenses surface mount.
4. Exhaust Duct: Galvanized steel, except stainless steel where exposed to view inside the building.
5. Exhaust Fan: Manufacturer's standard type (complying with section 5 of NFPA-96) (see also Mech. Section).

M. Fire Extinguishing System:

1. Material: System is to utilize a Wet Chemical system complying with NFPA No. 17 and 96.
2. The bidder is responsible to submit the necessary shop drawings and submittals required by the local authorities for a review of the Fire and Life Safety requirements of the specified system(s).
3. Shop Drawings: The Fire Suppression System Contractor is to submit shop drawings for the fire suppression system that are to include:
 - a. The name of the Owner/Occupant.
 - b. Site address and compass orientation indication.
 - c. Installing Fire Suppression Contractor's name, address and telephone number.
 - d. Graphic representation of scale for the drawings.
 - e. Hazard analysis with sufficient detail and dimensions to evaluate the hazard. Details are to include materials involved, location and arrangement and exposure to the hazard, combustibles, air handling equipment and heat sources.
 - f. Information and calculations on the amount of suppression agent to be used.
 - g. Indicate the size, length and arrangement of connected piping or piping and hose, including all fittings.
 - h. Indicate the description and location of nozzles to be used including flow rates of nozzles for engineered systems.
 - i. Indicate with details to identify apparatus and devices to be used.
 - j. Indicate location of all alarm-initiating and alarm-signaling devices.
 - k. Indicate location and function of operating devices, auxiliary equipment and electrical circuitry if used.
 - l. Show location of annunciation panel.
 - m. Show location of power connection for fire extinguishing system as applicable including breaker number(s).
 - n. Show location of gas connection and shut off as applicable.
 - o. Identify type and location of manual activating device to operate the fire extinguishing system.
4. Certificate of Compliance: The Fire Suppression System Contractor must provide at the completion of the project, certification that the system has been installed in accordance with the approved plans and the manufacturer's listed installation and maintenance manual.
5. Operation Instructions and As-Built Drawings: The Fire Suppression System Contractor must provide at the completion of the project, one set of manufacturer's listed installation and maintenance manuals or listed owner's manual that describes the system's operation, required maintenance and recharging to the Owner.
6. System Alterations: When field conditions necessitate any substantial changes from the approved plans, the corrected As-Installed plans are to be prepared and submitted.
7. Equipment List: Provide a complete equipment list for approval and before the installation of the fire alarm system identifying:
 - a. Type and model of fire extinguishing devices.
 - b. Manufacturer of fire extinguishing devices.

- c. Manufacturer catalog data sheets for fire extinguishing devices.
- d. Listing and capability of all equipment with the fire extinguishing system.

N. Shop Painting:

- 1. Clean and prepare metal surfaces to be painted; remove rust and dirt, apply treatment to zinc-coated surface that has not been mill-phosphatized. Coat welded and abraded areas of zinc-coated surfaces with galvanized repair paint. Apply 1.5 mil (dry film thickness) metal primer coating, followed by 2, 1.0 mil (dry film thickness) metal, enamel finish coatings. Bake primer and finish coatings in accordance with paint manufacturer's instructions for a baked enamel finish.

2.4 REFRIGERATION EQUIPMENT

- A. Provide either single or multiple compressor units, as recommended by the manufacturer for the sizes and variations between connected evaporator loads as indicated.
- B. Provide units of the capacities indicated, arranged to respond to multiple-evaporator thermostats and defrosting timers. Include coils, receivers, compressors, motors, motor starters, mounting bases, vibrations insulation units, fans, dryers, valves, piping, insulation, gauges, winter control equipment, high ambient control equipment, and complete automatic control system.
- C. Refrigerant: Pre-charge units with type or types recommended by manufacturer for services indicated, with quick disconnect type connections where specified, ready to receive refrigerant piping runs to evaporators and (where remote) to condensers.
- D. Provide air-cooled condensers, located with the compressors, complete with refrigerant piping installed at the factory. Locate exterior units as shown with weather housings and protective enclosures.
- E. The minimum outdoor operating ambient temperature for design of units is -10 degrees F. Maximum ambient condition for load on the air cooled condenser is 95 degrees F. with 75% relative humidity in basically still air, or units to be provided with high ambient temperature controls.

2.5 CARBON DIOXIDE (CO2) EQUIPMENT

- A. Where equipment requires connection with compressor CO2 cylinder for operation, provide 2-cylinders manifold and control system (integral with equipment) with proper connectors for Department of Transportation's (DOT) approved type cylinders, and complete with cylinder safety devices and supports. Comply with ANSA B57.1 "Compressed Gas Cylinder Valve Outlet and Inlet Connections", and comply with applicable standards of the Compressed Gas Association.

2.6 MISCELLANEOUS MATERIALS AND FABRICATION

- A. Nameplate:
 - 1. Wherever possible, locate nameplates and labels on manufactured items in accessible position, but not within customer's normal view. Do not apply nameplates or labels on custom-fabricated work, except as required for compliance with governing regulations, insurance requirements or operator performance.

B. Manufactured Equipment Items:

1. Furnish items as scheduled or herein specified. Verify dimensions, spaces, rough in and service requirements and electrical characteristics before ordering. Provide all trim, accessories, and miscellaneous items for complete installation.

PART 3 - EXECUTION

3.1 INSPECTION AND PREPARATION

- A. The installer of the Food Service Equipment must examine the rough in of mechanical and electrical services by others, and the conditions under which the work is to be done and must verify dimensions of the services and substrates before fabricating the work. Notification of unsatisfactory conditions for the proper installation of the Food Service Equipment must be made in writing to the General Contractor.
- B. Do not proceed with the fabrication and installation until unsatisfactory dimensions and conditions have been corrected in a manner acceptable to the installer.
- C. Bidder is to verify site conditions to allow for the physical installation of each piece of equipment. Any consideration or associated cost required allowing for the installation is to be the responsibility of the bidder.

3.2 INSTALLATION

- A. Water Connections: Install water connections and outlets at each item of equipment, with air gaps, vacuum breakers and similar provisions to comply with governing regulations, but not less than compliance with ANSI Standards A40.4 and A40.6.
- B. Gas burners: Install gas burning appliances, including gas vents if necessary, to comply with NFPA No. 54.
- C. Electrical Work: Assemble electrical components of equipment in accordance with applicable "Standards of Installation" by the National Electrical Contractors Association.
- D. Service Line and Equipment Connections: Refer to division 15 sections for piping connections and piping systems. Refer to division 16 sections for electrical work including equipment connections.
- E. Jointing and Anchoring:
 1. Set each items of non-mobile and non-portable equipment securely in place and level and adjust to correct height. Anchor to supporting substrate where indicated and where required for sustained operation and use without shifting or dislocation. Conceal anchorage wherever possible. Adjust counter tops and other work surfaces to a level tolerance of 1/6" (maximum offset, and plus-or-minus on dimensions, and maximum variation in 2'-0" run from level of indicated slope).
 2. Complete field assemble joints in the work (joints which cannot be completed in the shop) by welding, bolting and gaskets, or similar methods as indicated. Grind welds smooth and restore finish. Set or trim flush, except for "T" gaskets as indicated.
 3. Treat enclosed spaces (inaccessible after equipment installation) by covering horizontal surfaces with powdered borax at a rate of 4 oz. per sq. ft..

4. Install closure plates and strips where required, with joints coordinated with units of equipment.
5. Install sealant and gaskets all around each unit to make joints air tight, waterproof, vermin-proof, and sanitary for cleaning purposes.
6. In general, make sealed joints not less than 1/8" wide, and stuff with backer rod to shape sealant bead properly, at 1/4" depth.
7. Shape exposed surfaces of sealant slightly concave, with edges flush with faces of material joint.
8. At internal-corner joints, apply sealant or gasket to form a sanitary cove, of not less than 3/8" radius.
9. Provide sealant-filled or gasket joints up to 3/8" joint width; metal closure strips for wider joints, with sealant application each side of strips. Anchor gaskets mechanically or with adhesives to prevent displacement.

3.3 CLEANING:

- A. After completion of installation, and completion of other major work in Food Service areas, remove protective coverings, if any, and clean Food Service Equipment, internally and externally.
- B. Restore exposed and semi-exposed finishes to remove abrasions and other damages; polish exposed-metal surfaces; touch-up painted surfaces. Replace work that cannot be successfully restored.
- C. Remove and dispose off site any and all crating and packaging material.

3.4 TESTING AND START-UP:

- A. Delay the start-up of equipment until service lines have been tested, balanced, and adjusted for pressure, voltage and similar consideration; and until water and steam lines have been cleaned and treated for sanitation.
- B. Test each item of operational equipment to demonstrate that it is operating properly, and that controls and safety devices are functioning. Repair or replace equipment that is found to be defective in its operation, including units that are below capacity or operating with excessive noise or vibration.
- C. Final Cleaning: After testing and start-up, clean and sanitize the Food Service Equipment, and leave in a condition ready for use in food service.

3.5 INSTRUCTIONS AND TRAINING:

- A. Instruct the owner and any and all representatives of the owner in the proper operation and maintenance of each piece of operational equipment.

3.6 WARRANTY:

- A. Each item is to include a parts and labor warranty of no less than one year, and longer as standard to the manufacturer's warranty.

3.7 INSTALLATION SCHEDULE:

- A. Bidder is to review the projected construction schedule with the General Contractor prior to bidding and be able to accomplish the installation of the Food Service Equipment within the requirements of the project schedule.

3.8 BIDDING FORMAT:

- A. Bidder will provide a completed bid form for each section of work being bid, as per the General Conditions of this specification.
- B. The successful bidder will be required to submit an itemized list with individual costs for each piece of equipment included in the bid. Freight is to be included in the itemized cost for each item. Installation costs are to be itemized separately. A total amount is to be listed that includes all costs to complete the work.
- C. Change orders requested by the owner or required by job conditions to add to the equipment requirements are to be on a 'cost plus' basis. Bidder is to submit a proposal for a percentage amount that will be applied to equipment costs for all change orders.
- D. Change orders to delete equipment items will be directly related to the itemized costs breakdown provided.

3.9 DISCREPANCIES:

- A. Any discrepancies or errors located or identified in or between the specifications and plans are to be brought to the attention of the designer in writing prior to, or with the bid submittal. Any such item not identified which would cause the bid to increase, will be the responsibility of the bidder to correct.

3.10 ACCEPTABLE SUBSTITUTE MANUFACTURERS:

- A. The items listed are to be bid as specified. Manufacturers requesting to be approved as an equal substitute are to submit their request in writing to the Food Service Consultant for consideration at least (7) days prior to the bid date. Manufacturers will be considered approved and will be accepted as part of the bid only after being stated as such in writing in the form of an addendum and will be accepted only if they equally meet the specifications and standards of the specified manufacturer. A list of approved substitute manufacturers is to be submitted with the successful bidders itemized equipment list.
- B. The bidder is solely responsible to insure that the requirements of any alternate or approved equal manufacturer's piece of equipment provided by them, comply with the design intent of these documents including physical size, utility requirements and function.

3.11 EXCLUSIONS:

- A. The Owner reserves the right to exclude any and all items from the final contract.

PART 4 - ITEMIZED LIST OF EQUIPMENT

ITEM #K-01	HIGH CAPACITY DRY STORAGE SHELVING
Quantity:	(1) lot
Manufacturer:	Inter Metro
Model Number:	qwikTRACK, Chrome
Dimensions:	(4) 42"W x 21"D x 86"H Fixed End Units (4) 42"W x 21"D x 86"H Mobile Units
Utility Requirements:	None
Accessories:	A) Lot to include: (4) #BTEC Stationary Chrome End Unit Assemblies. (4) #BTMC Mobile Chrome Unit Assemblies (3) #LBTS15NA 7' Long Track Sets. (40) #2142NC shelves.
Installation Instructions:	A) Assemble, set and level as per plan. (Verify actual field dimensions for compliance.)
ITEM #K-02	DRY STORAGE SHELVING
Quantity:	(1) lot
Manufacturer:	Inter Metro
Model Number:	qwikTRACK, Chrome
Dimensions:	(1) 54"W x 24"D x 86"H Fixed Shelving Units (3) 48"W x 24"D x 86"H Fixed Shelving Units
Utility Requirements:	None
Accessories:	A) Lot to include: (5) #2454NC shelves. (15) #2448NC shelves. (10) #86PS posts. (30) #9995Z 'S' clips
Installation Instructions:	A) Assemble, set and level as per plan. (Verify actual field dimensions for compliance.)
ITEM #K-03	WALK-IN COOLER BOX
Quantity:	(1) lot
Manufacturer:	Kolpack
Model Number:	#NS (Nominal Size/Custom)
Dimensions:	16'-4 1/2"W x 8'-8 1/2"D x 9'-0"H, as per plan
Utility Requirements:	A) 115/60/1, 1.76 amps at cooler door. Interconnect with (4) LED lights.
Accessories:	A) Provide 36" stainless steel door unit with view window. B) Provide (3) additional LED vapor proof lights for a total of (4) lights at in cooler box. C) Provide vacuum relief heated air vent at door. D) Provide stainless steel side trim to walls. E) Provide with integral 4" insulated floor panel with Structural Era Floor with overlay. F) Provide additional door hinge to door. G) Stainless steel finish on exposed exterior surface of box. Galvalume finish on all other exterior surfaces of box. H) White galvalume finish on interior exposed surface of box. I) Provide 'Thermo Curtain' at door. J) Provide with integral interior ramp.

- Installation Instructions:
- A) Assemble and set in place as per plans to sub floor with PVC floor screens.
 - B) General Contractor to provide floor tile and base up to exterior wall panels and into ramp.
 - C) Tile floor with base to be applied after box installation. Door height to compensate for floor tile dimension.

ITEM #K-04A

COOLER REFRIGERATION SYSTEM: CONDENSER

- Quantity: (1) system
 Manufacturer: Kolpak
 Model Number: #PC99MOP-2E
 Dimensions: 33"W x 26"D x 20"H
 Utility Requirements: A) 208/60/1, 11.4 amps, 1 H.P. (To be connected to emergency generator)
 B) Interconnect refrigeration lines with Evaporator Coil, item #K-4B
- Accessories: A) Include: Pre piped Tecumseh hermetic compressors with dryers, sight glasses and head pressure controls; pre-wired electrical panel, defrost clock, pressure controls and crankcase heaters. (Verify all requirements with manufacturer).
 B) Interconnect with Evaporator Coil, item #K-4B.
 C) Verify location of unit on roof above.
 D) Provide with low ambient temperature kit.
 E) Provide with mounting skids.
 F) Size to maintain +35°F in box as per plan.
 G) Exterior housing.
- Installation Instructions: A) Mount on roof as per manufacturers shop drawings.
 B) Interconnect refrigeration lines with Evaporator Coil, item #K-4B.
 C) Set refrigeration equipment on roof curb, mount evaporator coils in cooler box, provide and install expansion coils, T-Stat, solenoid valves.
 D) Provide and install refrigeration piping, insulation, fittings, hangers, supports and hook-ups.
 E) Charge each system with the refrigerant as specified by the manufacturer.
 F) Check, test, start up and final adjustments are to be provided.
 G) General Contractor to provide floor and wall penetrations to roof installation location, roof curb and roof penetration sealing at refrigeration lines.
 H) Electrical Contractor to interconnect refrigeration system as required.

ITEM #K-04B

COOLER REFRIGERATION SYSTEM: EVAPORATOR COIL

- Quantity: (1) system
 Manufacturer: Kolpak
 Model Number: #AM26-117-1EC-PR-4
 Dimensions: 44"W x 16"D x 17"H
 Utility Requirements: A) 115/60/1, 1.6 amps. (To be connected to emergency generator)
 B) Indirect drain to floor sink.
 C) Interconnect refrigeration lines with item #K-4A.
 Accessories: A) Mounting hardware.
 B) Size to maintain +35°F in box as per plan.
 C) Provide with temperature sensor capable of monitoring and reporting 24 hour temperature record via communication cable to owner computer system.
 Installation Instructions: A) Mount from Walk-In Box ceiling.
 B) Interconnect with Refrigeration Condenser Item #K-4A.
 C) Plumbing Contractor to provide and install drain line from evaporator coil in box to floor sink.

ITEM #K-05

WALK-IN BOX SHELVING

- Quantity: (1) lot
 Manufacturer: Inter Metro
 Model Number: Super Erecta, Metro Seal III
 Dimensions: (2) 60"W x 24"D x 74"H
 (2) 54"W x 24"D x 74"H
 (1) 42"W x 24"D x 74"H
 Utility Requirements: None
 Accessories: A) Lot to include: (8) #2460NK3 shelves
 (8) #2454NK3 shelves
 (4) #2442NK3 shelves
 (14) #86PK3 posts
 (24) #9995Z 'S' clips
 Installation Instructions: A) Assemble, set and level as per plan. (Verify actual field dimensions for compliance.)

ITEM #K-06

WALK-IN DUNNAGE RACK

- Quantity: (1) lot
 Manufacturer: InterMetro, Stainless Steel
 Model #: Super Erecta, (1) #MHP55S; (1) #MHP53S
 Dimensions: (1) 48"W x 24"D x 14-1/2"H
 (1) 36"W x 24"D x 14-1/2"H
 Utility Requirements: None
 Accessories: A) Wire Mat.
 B) Set of heavy-duty casters.
 C) Stainless steel finish.
 Installation Instructions: A) Assemble and set in place as per plan.

ITEM #K-07

SPEED RACK: MOBILE

Quantity: (4) each
 Manufacturer: New Age
 Model Number: #1331 PBCL
 Dimensions: 21"W x 28"D x 69"H
 Utility Requirements: None
 Accessories: A) Perimeter bumpers.
 B) (20) 18" x 26" pan capacity.
 C) Set of heavy-duty locking casters.
 Installation Instructions: A) Assemble and set in place as per plan.

ITEM #K-08

LOCKERS: PROVIDED BY OTHER SECTION

Quantity: (5) each
 Manufacturer: Penco
 Model Number: #6161V
 Dimensions: 12"W x 12"D x 72"H
 Utilities: None
 Accessories: A) Vanguard double tier locker.
 B) Two door/compartments per section, constructed of painted metal with louvered front for ventilation and lockable latching system.
 C) Verify with architect the finish color.
 D) Matching trim to walls at sides and top
 Installation Notes: A) Assemble, set and level as per plan.

ITEM #K-09

MOP SINK: PROVIDED BY PLUMBING SECTION

Quantity: (1) each
 Manufacturer: Provided by Plumber
 Model Number: -
 Dimensions: -
 Utility Requirements: Verify utility requirements with contractor
 A) 1/2" hot and cold water.
 B) 1-1/2" direct drain.
 Accessories: A) Faucet and drain.
 Installation Instructions: A) Mount as per plan.

ITEM #K-10

SPARE NUMBER

ITEM #K-11

STAINLESS STEEL WALL CABINET

Quantity: (1) each
 Manufacturer: Advance Tabco
 Model Number: #WCH-15-24-300
 Dimensions: 24"W x 15"D x 33"H
 Utility Requirements: None.
 Accessories: A) (1) #TA-46 Door lock.
 B) Provide stainless steel trim to side walls.
 Installation Instructions: A) Mount to wall at 60" to the bottom of the cabinet.
 B) Seal to wall.

ITEM #K-12

STAINLESS STEEL CORNER GUARDS

Quantity: (1) lot
 Manufacturer: Custom Metal Fabricated
 Model Number: Custom
 Dimensions: 3" x 3" x 72"H
 Utility Requirements: None
 Accessories: A) Lot to include (11) guards as per plan.
 Installation Instructions: A) Attach to wall with glue and stainless steel screws as per plan.

ITEM #K-13

HAND SINK

Quantity: (2) each
 Manufacturer: Advance
 Model Number: #7-PS-62
 Dimensions: 17"W x 15"D x 18"H
 Utilities: A) 1/2" hot and cold water.
 B) 1-1/2" Direct drain.
 Accessories: A) Owner to provide towel and soap dispenser.
 B) Provide with gooseneck faucet with knee valve and drain.
 C) Provide with right side splash.
 Installation Notes: A) Clip and seal to wall as per plan.
 B) General Contractor to provide blocking in wall as required.

ITEM #K-14

ICE MAKER and BIN

Quantity: (1) each
 Manufacturer: Manitowoc
 Model Number: #IY-0504A
 Dimensions: 30"W x 25"D x 27"H (34"D x 72"H with Bin)
 Utility Requirements: A) 3/8" cold water.
 B) 1/2" indirect drain to floor sink. (Ice Maker).
 C) 1/2" indirect drain to floor sink. (Ice Maker).
 D) 3/4" Indirect drain to floor sink. (Bin).
 E) 115/60/1, 14.2 amp.
 Accessories: A) Stainless steel finish.
 B) 570 lb. ice production capacity per 24 hours.
 C) Provide filter for incoming water.
 D) Self-contained, air cooled unit.
 E) Provide ice bin #B-570. 430 lb capacity.
 Installation Instructions: A) Water pressure to be 20 to 80 psi.
 B) Mount to Bin as per plan.

ITEM #K-15

STAINLESS STEEL TWO COMPARTMENT PREP SINK

Quantity:	(1) each
Manufacturer:	Custom Fabricated
Model Number:	Custom
Dimensions:	6'-6"W x 2'-6"D x 36"H
Utility Requirements:	A) 1/2" Hot and cold water. B) 1-1/2" Indirect drain.
Accessories:	A) 6" Back splash. B) (2) Lever handle drains with basket strainers. C) Two 18" x 24" x 12" sink compartments. D) Two 18" drainboards at each side.
Installation Instructions:	A) Set and level as per plan. B) Clip and seal back splash to wall.

ITEM #K-16

PRE-RINSE SPRAY FAUCET

Quantity:	(1) each
Manufacturer:	T & S Brass
Model Number:	#MPR-8WLN-08
Dimensions:	22"H
Utility Requirements:	A) 1/2" hot and cold water.
Accessories:	A) Provide wall bracket. B) Includes 8" swing faucet. C) Splash mounted. D) #B-0108 Swing nozzle spray head.
Installation Instructions:	A) Mount to Two Compartment Sink, item #K-15, as per plan.

ITEM #K-17

STAINLESS STEEL WALL SHELF

Quantity:	(1) each
Manufacturer:	Custom Metal Fabricated
Model Number:	Custom, as per plans and details.
Dimensions:	6'-6"W x 1'-2"D.
Utility Requirements:	None
Accessories:	A) Provide with (3) mounting brackets.
Installation Instructions:	A) Mount to wall at +60" A.F.F. as per plan. B) General Contractor to provide blocking in wall as required.

ITEM #K-18

STAINLESS STEEL WALL FLASHING

Quantity:	(1) lot
Manufacturer:	Custom Metal Fabricated
Model Number:	Custom, as per plans and details.
Dimensions:	6'-6"W on wall behind Two Compartment Sink, item #K-15, as per plan.
Utility Requirements:	None
Accessories:	A) Stainless steel wall flashing on wall from floor base to ceiling. B) Provide stainless steel "J" and "T" trim at seams and at top edge.
Installation Instructions:	A) Mount to wall as required.

ITEM #K-19

KITCHEN SHELVING

Quantity: (1) lot
 Manufacturer: Inter Metro
 Model #: Super Erecta, Chrome
 Dimensions: (2) 60"W x 24"D x 86"H
 (1) 30"W x 24"D x 86"H
 Utility Requirements: None
 Accessories: A) Lot to include: (10) #2460NC shelves.
 (5) #2430NC shelves.
 (12) #86PZ posts
 Installation Instructions: A) Assemble, set and level as per plan. (Verify actual field dimensions for compliance.)

ITEM #K-20

SPARE NUMBER

ITEM #K-21

STAINLESS STEEL WORK TABLE

Quantity: (1) each
 Manufacturer: Custom Fabricated
 Model Number: Custom
 Dimensions: 8'-0"W x 2'-6"D x 36"H
 Utility Requirements: None.
 Accessories: A) 6" back splash.
 B) Stainless steel under shelf.
 C) (2) 15" x 20" Drawers mounted at each side.
 Installation Instructions: A) Set and level as per plan.
 B) Clip and seal back splash to wall.

ITEM #K-22

STAINLESS STEEL WALL SHELF

Quantity: (1) each
 Manufacturer: Custom Metal Fabricated
 Model Number: Custom, as per plans and details.
 Dimensions: 8'-0"W x 1'-2"D.
 Utility Requirements: None
 Accessories: A) Provide with (3) mounting brackets.
 Installation Instructions: A) Mount to wall at +60" A.F.F. as per plan. (Verify clearance to slicer, item #K-23 below)
 B) General Contractor to provide blocking in wall as required.

ITEM #K-23

SLICER: AUTOMATIC

Quantity: (1) each
 Manufacturer: Hobart
 Model #: #HS9
 Dimensions: 30"W x 24"D x 28"H
 Utilities: A) 115/60/1, 5.6 amps.
 Accessories: A) Removeable Knife.
 B) Automatic.
 Installation Instructions: A) Set in place as per plan.

ITEM #K-28

STAINLESS STEEL WORK TABLE

Quantity:	(1) each
Manufacturer:	Custom Metal Fabricated
Model Number:	Custom, as per plans and details.
Dimensions:	8'-0"W x 3'-0"D x 36"H
Utility Requirements:	None.
Accessories:	A) Stainless steel under shelf. B) (2) 15" x 20" Drawers mounted as per plan. C) Provide with (2) duplex receptacles mounted to underside of table at end and pre-wired to junction box ready for field connection. D) Anchor feet to floor to prevent movement.
Installation Instructions:	A) Set and level as per plan.

ITEM #K-29

STAINLESS STEEL UTENSIL RACK:

Quantity:	(1) each
Manufacturer:	Custom Metal Fabricated
Model Number:	Custom, as per plans and details.
Dimensions:	6'-0"W x 2'-0"D
Utility Requirements:	None
Accessories:	A) Triple 1-1/2" x 3/16" stainless steel bar type rack, table mounted with 1-5/8" O.D. stainless steel tubing supports extended through the tabletop below and anchored to the under shelf with concealed fasteners. B) Provide with (36) pot hooks.
Installation Instructions:	A) Mount to worktable, item #K-28 as per plan.

ITEM #K-30

SPARE NUMBER

ITEM #K-31

STAINLESS STEEL WORK TABLE

Quantity:	(1) each
Manufacturer:	Custom Metal Fabricated
Model Number:	Custom, as per plans and details.
Dimensions:	8'-0"W x 3'-0"D x 36"H
Utility Requirements:	None.
Accessories:	A) Stainless steel under shelf. B) (2) 15" x 20" Drawers mounted as per plan. C) Provide with (2) duplex receptacles mounted to underside of table at end and pre-wired to junction box ready for field connection. D) Anchor feet to floor to prevent movement.
Installation Instructions:	A) Set and level as per plan.

ITEM #K-32

STAINLESS STEEL EXHAUST HOOD with MAKE UP AIR PLENUM:
TYPE I

- Quantity: (2) each
 Manufacturer: Aqua-Matic
 Model #: #AM-ND-2-PSP-F
 Dimensions: (2) Sections at 8'-0"W x 5'-0"D (6'-2" at MUA) x 2'-0"H
 Utilities: A) 120/60/1, 600 watt. Wired to remote control panel.
 B) Total exhaust for both hoods 3200 CFM at (2) duct collars at 14"D" each 1600 CFM each at 0.551" SP and 1497 Duct Velocity.
 C) Total make-up air for both hoods 2560 CFM (4) duct collars at 8" x 36" each 640 CFM each at 0.183" SP.
- Accessories: A) Wall canopy type units mounted to center wall and from structure above. Provide hanger rods and seismic restraints.
 B) Hoods to be UL listed, #710, NFS Approved and built in compliance to the prevailing NFPA Standard #96.
 C) Captrate Solo filters with hooks.
 D) Integral 3" dead air space as required.
 E) Provide hanger rods and seismic restraints.
 F) Provide duct heat sensor assembly at each exhaust duct connections to comply with current code. Connect to remote control panel.
 G) Recessed LED light fixtures.
 H) Stainless steel enclosure panels from hood to ceiling.
 I) Full-length concealed grease drip tray below the filters pitched to an enclosed metal grease container.
 J) Perforated front make-up air plenum at each hood.
 K) Provide control panel to be mounted in wall recess as per plan.
 L) Provide duct heat sensor assembly at each exhaust duct connections and control box to comply with current code.
- Installation Notes: A) Mount from structure above as per plan. (1,106 lb.)
 B) Mechanical Contractor to connect exhaust and make-up air ducts to duct collars.
 C) Heat Sensor to be installed by K.E.C. and interconnected by the Electrical Contractor to the hood exhaust system as required to activate exhaust system when activated by heat.

ITEM #K-33

FIRE PROTECTION SYSTEM

- Quantity: (1) lot
 Manufacturer: Ansul
 Model Number: #R-102
 Dimensions: -
 Utility Requirements: -
 Accessories: A) Provide gas shut off valve and five electrical shut off contacts as required for protected equipment, for installation by mechanical and electrical contractors.
- Installation Instructions: A) Provide a complete self-contained and certified system.
 B) To protect Exhaust Hoods, items #K-32. Tanks to be located on end of hood as per plan. Verify placement.
 C) All conduits and piping to be concealed in walls and ceiling. Exposed piping in hood to be chrome.
 D) Verify placement of emergency pull station with architect.

ITEM #K-34

STAINLESS STEEL WALL FLASHING

Quantity: (1) lot
 Manufacturer: Custom Metal Fabricated
 Model Number: Custom, as per plans and details.
 Dimensions: (2) 8'-0"W on wall behind and to underside of Exhaust Hoods, item #K-32, as per plan. Provide opening at wall opening with sill, side and head jamb trim.

Utility Requirements: None
 Accessories: A) Stainless steel wall flashing on cook line wall from floor base to bottom of hood.
 B) Provide stainless steel "J" and "T" trim at seams and at top edge.

Installation Instructions: A) Mount to wall as required.

ITEM #K-35

STACKED CONVECTION OVEN: ELECTRIC

Quantity: (1) each
 Manufacturer: Vulcan
 Model Number: #VC66E
 Dimensions: 41"W x 42"D x 70"H

Utility Requirements: A) 208/60/3, 35.2 amps. (2) each per item.
 Accessories: A) Stainless steel finish including top and sides.
 B) Heavy duty casters, (2) with locks.
 C) Double oven configuration.
 D) Dependent doors.

Installation Instructions: A) Set in place as per plan.

ITEM #K-36

STACKED CONVECTION OVEN: EXISTING TO BE RE-USED

Quantity: (1) each
 Manufacturer: Verify with Existing
 Model Number: Verify with Existing
 Dimensions: Verify with Existing
 Utility Requirements: Verify with Existing
 Accessories: A) (2) each 208/60/3, 35 amps.
 As per Existing

Installation Instructions: A) K.E.C. to remove existing Convection Oven and store for re-installation.
 B) Assemble, set and level as per plan. (Verify actual field dimensions for compliance.)

ITEM #K-37

STACKED COMBI STEAMER/OVEN

- Quantity: (1) each
 Manufacturer: Rational
 Model Number: #SCC-62/102-E
 Dimensions: 43"W x 46"D x 74"H
 Utility Requirements:
- A) (1) each 208/60/3, 61.4 amps.
 - B) (1) each 208/60/3, 102.7 amps.
 - C) (2) each 3/4" cold water. Drinking quality only. (21) to (87) psi required. Consumes 3 to 6.6 GPM. Provide flexible connection to allow for movement of oven.
 - D) (2) each 1" cold water direct connection to drain tempering device.
 - E) (2) each 2" indirect drain to floor sink.
- Accessories:
- A) HDC HiDensityControl
 - B) ELC Efficient Level Control.
 - C) Right hand door hinge.
 - D) CleanJet auto-clean, Care Control self-clean.
 - E) (10) 18" x 26" or (20) 12" x 20" pan capacity.
 - F) Accessories including:
 - a. (10) each 12"x 20" x 2-1/2" perforated gastronorm pans.
 - b. (5) each 12" x 20" stainless steel grid shelves.
 - c. (10) each 12" x 20" fry baskets.
 - d. (4) each 12" x 20" Teflon perforated baking trays.
 - e. (4) 12" x 20" non-stick coated pans.
 - G) Rational Certified Installation.
 - H) Rational Certified Chef training
 - I) Installation Kit "10"
 - J) 6" feet
 - K) Water filter to meet quality standards set above.
 - L) Provide (2) CDF #DTV-HV drain water tempering kit for installation at drain by plumbing contractor.
- Installation Instructions:
- A) Set in place on stand and level as per plan, set as far back under the hood as possible.
 - B) Adjust for local altitude as required.
 - C) Plumbing Contractor to provide water connections and copper drain connection.

ITEM #K-38	STEAMER
Quantity:	(1) each
Manufacturer:	Cleveland
Model Number:	24-CEA-10
Dimensions:	24"W x 36"D x 66"H
Utility Requirements:	A) 208/60/3, 91.7 amps. B) 3/8" Cold water. 35 PSI Min. / 60 PSI Max. Generator C) 3/8" Cold water. 35 PSI Min. / 60 PSI Max. Condenser D) 1-1/2" Indirect drain to floor sink.
Accessories:	A) Left hand door hinging as per plan. B) Claris or 3MCuno water filter system to provide proper water quality at Generator connection. C) Provide drain water tempering kit for installation at drain by plumbing contractor.
Installation Instructions:	A) Set and level as per plans. Bolt to floor. B) Water to be minimum requirements of: Total dissolved solids of no greater than 60 parts per million; pH no greater than 7.5; silica less than 13 parts per million; alkalinity less than 20 parts per million. C) Adjust for local altitude and environmental conditions as required.
ITEM #K-39	SPARE NUMBER
ITEM #K-40	SPARE NUMBER
ITEM #K-41	HOT HOLDING/PROOFING CABINET: EXISTING TO BE RE-USED
Quantity:	(1) each
Manufacturer:	Verify with Existing
Model Number:	Verify with Existing
Dimensions:	Verify with Existing (27"W x 30"D x 71"H)
Utility Requirements:	Verify with Existing A) 120/60/1, 17.5 amps.
Accessories:	As per Existing A) Set of heavy-duty locking casters. B) Viewing windows. C) Dutch doors. D) Hinged as per plan.
Installation Instructions:	A) K.E.C. to remove existing Warming Cabinets and store for re-installation. B) Set in place as per plan.

ITEM #K-42

REACH-IN REFRIGERATOR

Quantity: (1) each
 Manufacturer: True
 Model Number: #STR1R-1S-HC
 Dimensions: 28"W x 34"D x 85"H
 Utility Requirements: A) 115/60/1, 3.8 amps.
 Accessories: A) Self-contained, air-cooled refrigeration.
 B) Finished sides.
 C) Door lock.
 D) Casters, two with locks.
 E) Kit #4 Chrome shelves on top and bottom sections.
 Installation Instructions: A) Set in place as per plan.

ITEM #K-43

STAINLESS STEEL SERVICE COUNTER

Quantity: (1) each
 Manufacturer: Custom Metal Fabricated
 Model Number: Custom, as per plans and details.
 Dimensions: 28'-4"W x 1'-10"D (3'-0"D at wall openings) and 4'-0"W x 2'-0"D right return x 36"H, 34" at front tray slide (Verify with field measurements.)
 Utility Requirements: None
 Accessories: A) Finished sides and back.
 B) 34"H x 11"D Stone top tray slide with inlaid stainless steel strips mounted on wall opening top as per plan and detail.
 C) 36"H x 2'-1"D Stone top on solid stainless steel work surface as per details
 D) Unit includes:
 Install (1) Four Pan Hot/Cold/Frozen Pan, item #K-45, and (1) Three Pan Hot/Cold/Frozen Pan, item #K-46 into unit as per plans and details.
 E) Provide apron and bottom shelf with turned up back, as per plans details.
 F) Install controls in apron panel as per details.
 G) Stainless steel adjustable bullet feet on steel frame as per details.
 H) Removable stainless steel base plate attached to counter feet at back.
 I) Stone selection as per architect's finish schedule.
 Installation Instructions: A) Set and level as per plan.
 B) Build in items #K-45 and #K-46, as per plan.
 C) Build on item #K-44, as per plan.

ITEM #K-44

FOOD GUARD SERVING SHELF

Quantity: (1) lot
 Manufacturer: BSI
 Model Number: #XG3500-2
 Dimensions: (2) 11'-8"W x 14"D x 1'-11"H. Verify with field measurements.
 Utility Requirements: None
 Accessories: A) Each with (2) 4'-3" and (1) 3'-2" sections and seven supports with adjustable front food shields and top shelf in stainless steel finish at Serving Counter, item #K-43, as per plans and details. Verify finish with architect.
 B) Stainless steel under-counter heavy-duty flange supports mounted through counter top to base counter structure.
 C) 1" Radius corners, 3/8" Tempered Glass.
 Installation Instructions: A) Build onto Service Counters, item #K-43.

ITEM #K-45

HOT/COLD/FROZEN FOOD WELLS: FOUR SECTION

Quantity: (1) each
 Manufacturer: LTI
 Model Number: Quick Switch Slim Line #QSCHFP-4S-T
 Dimensions: 98"W x 17"D x 30"H
 Utilities: A) 3/4" indirect drain to floor sink.
 B) 120/60/1, 23.7 Amp.
 Accessories: A) Drain manifold with four quarter turn ball valve drains and one exit.
 B) Individual thermostat controls per pan.
 C) Wet or dry operation per compartment.
 D) Mount controls to back apron of Counter, item #K-43.
 E) Manual water fill to individual compartments.
 Installation Notes: A) Build into Service Counter, item #K-43, as per plan.

ITEM #K-46

HOT/COLD/FROZEN FOOD WELLS: THREE SECTION

Quantity: (1) each
 Manufacturer: LTI
 Model Number: Quick Switch Slim Line #QSCHFP-3S-T
 Dimensions: 74"W x 17"D x 30"H
 Utilities: A) 3/4" indirect drain to floor sink.
 B) 120/60/1, 18.7 Amp.
 Accessories: A) Drain manifold with four quarter turn ball valve drains and one exit.
 B) Individual thermostat controls per pan.
 C) Wet or dry operation per compartment.
 D) Mount controls to back apron of Counter, item #K-43.
 E) Manual water fill to individual compartments.
 Installation Notes: A) Build into Service Counter, item #K-43, as per plan.

ITEM #K-47

STAINLESS STEEL WALL SHELF

Quantity: (1) each
 Manufacturer: Custom Metal Fabricated
 Model Number: Custom, as per plans and details.
 Dimensions: 4'-0"W x 1'-2"D.
 Utility Requirements: None
 Accessories: A) Provide with (2) mounting brackets.
 Installation Instructions: A) Mount to wall at +60" A.F.F. as per plan.
 B) General Contractor to provide blocking in wall as required.

ITEM #K-48

STAINLESS STEEL WALL SHELF

Quantity: (1) each
 Manufacturer: Custom Metal Fabricated
 Model Number: Custom, as per plans and details.
 Dimensions: 1'-6"W x 1'-2"D.
 Utility Requirements: None
 Accessories: A) Provide with (2) mounting brackets.
 Installation Instructions: A) Mount to wall at +60" A.F.F. as per plan.
 B) General Contractor to provide blocking in wall as required.

ITEM #K-49

CASHIER STAND: MOBILE. EXISTING TO BE RE-USED

Quantity: (2) each
 Manufacturer: Verify with Existing
 Model Number: Verify with Existing
 Dimensions: Verify with Existing (46"W x 28"D x 34"H)
 Utility Requirements: None
 Accessories: As per Existing
 Installation Instructions: A) K.E.C. to remove existing Cashier Stands and store for re-installation.
 A) Set in place as per plan

ITEM #K-50

TRAY-SILVERWARE DISPENSER CART

Quantity: (2) each
 Manufacturer: Cambro
 Model Number: #TDCR12 (Verify tray size)
 Dimensions: 39"W x 23"D x 42"H
 Utility Requirements: None
 Accessories: A) Bottom cart with casters with locks.
 B) Cutlery rack top with (12) Nylon flatware cylinders.
 Installation Instructions: A) Set in place as per plan.

ITEM #K-51

MILK COOLERS: MOBILE. EXISTING TO BE RE-USED

Quantity:	(2) each
Manufacturer:	Verify with Existing
Model Number:	Verify with Existing
Dimensions:	Verify with Existing (58"W x 34"D x 42"H)
Utility Requirements:	Verify with Existing A) 115/60/1, 8.2 amps.
Accessories:	As per Existing A) Set of casters, two with brakes. B) Lid Locking device. C) Cord and plug. D) White exterior, stainless steel interior.
Installation Instructions:	A) K.E.C. to remove existing Milk Cooler and store for re-installation. A) Set in place as per plan

ITEM #K-52

NUTRITION CART: MOBILE. EXISTING TO BE RE-USED

Quantity:	(1) each
Manufacturer:	Verify with Existing
Model Number:	Verify with Existing
Dimensions:	Verify with Existing (69"W x 43"D x 34"H)
Utility Requirements:	None
Accessories:	As per Existing
Installation Instructions:	A) K.E.C. to remove existing Nutrition Cart and store for re-installation. A) Set in place as per plan

ITEM #K-53

STAINLESS STEEL DIRTY DISH TABLE

Quantity:	(1) each
Manufacturer:	Custom Metal Fabricated
Model Number:	Custom, as per plans and details.
Dimensions:	8'-9" x 5'-6" "L" x 2'-6"D x 34"H. Verify with field measurements.
Utility Requirements:	None
Accessories:	A) Built-in pre-rinse sink. B) 8" back splash. C) 4'-6"W Stainless steel under shelf. D) Provide trough drain with removable perforated top insert at dishwasher entry.
Installation Instructions:	A) Set and level as per plans. B) Clip and seal back splash to wall. C) Verify entry requirements of dish machine to gently slope table back to machine.

ITEM #K-54

STAINLESS STEEL DISH RACK SHELF

Quantity: (1) each
 Manufacturer: Custom Metal Fabricator
 Model Number: Custom, as per plans and details.
 Dimensions: 8'-9"W x 21"D
 Utility Requirements: None
 Accessories: A) Provide with (3) mounting brackets.
 Installation Instructions: A) Mount to wall at +54" A.F.F. as per plan.
 B) General Contractor to provide blocking in wall as required.

ITEM #K-55

DISPOSER

Quantity: (1) each
 Manufacturer: Salvajor
 Model Number: #150-CA-ARSS-(208/60/3)
 Dimensions: 13"Diameter x 19"H
 Utility Requirements: A) 1/2" Cold water.
 B) 2" Direct drain.
 C) 208/60/3, 1-1/2 HP
 Accessories: A) 3-1/2" Sink Assembly.
 B) Pre-wired control panel, mounted to Dirty Dish Table, item #K-53.
 C) Short body to allow for mounting under sink compartment.
 Installation Instructions: A) Mount to pre-rinse sink compartment of item #K-53.
 B) Verify fit under sink.

ITEM #K-56

PRE-RINSE SPRAY

Quantity: (1) each
 Manufacturer: T&S Brass
 Model Number: #B-0163/B-0107
 Dimensions: 33"H
 Utility Requirements: A) 1/2" hot and cold water.
 Accessories: A) Provide wall bracket.
 B) Splash Mount.
 C) Provide with B-0107 Spray Valve
 Installation Instructions: A) Mount to Dirty Dish Table, item #K-53, as per plan.

ITEM #K-57

DISHWASHER: ELECTRIC

- Quantity: (1) each
 Manufacturer: Hobart
 Model Number: #CL44eN-EGR ELECTRIC
 Dimensions: 44"W x 24"D x 67"H
 Utilities:
- A) 1/2" Hot water connection. (Minimum 110 F)
 - B) 1/2" Cold water connection. (Max 80 F)
 - C) 1/2" Cold water connection. For drain tempering device.
 - D) 1/8" Inlet to be provided for detergent dispenser as required.
 - E) 2" indirect drain to extra deep floor sink.
 - F) 208/60/3, 55.7 amps. Motors, Controls and Electric Tank Heat.
 - G) 208/60/3, 83.9 amps. Booster Heater.
- Accessories:
- A) Electric tank heat.
 - B) Right to left operation as per plan.
 - C) Integral booster heater.
 - D) Stainless steel finish.
 - E) Single point electrical connection.
 - F) Provide with table limit switch installed in clean dish table, item #K-62.
- Installation Notes:
- A) Set and level owner provided unit as per plan.
 - B) Attach dish tables as required.

ITEM #K-58

STAINLESS STEEL VENT HOOD: TYPE II

- Quantity: (1) each
 Manufacturer: Aqua-Matic
 Model Number: #AM-VHB-G
 Dimensions: 6'-0"W x 4'-0"D x 2'-0"H
 Utility Requirements:
- A) Exhaust connection to one 12" diameter exhaust duct collar at (900) CFM for a total exhaust of (900) CFM at 0.105" SP at 1146 Duct Velocity.
 - B) Mechanical system to provide (720) CFM tempered air while hood is on.
- Accessories:
- A) Stainless steel enclosure panels to ceiling and trim to wall.
- Installation Instructions:
- A) Mount from structure above at +6'-9" a.f.f. to the bottom of the hood, as per plan. (217) lb.
 - B) To be provided and installed by the Food Service Equipment Contractor.
 - C) General Contractor to provide structural reinforcement and support as required.

ITEM #K-59

STAINLESS STEEL WALL FLASHING

Quantity: (1) each
 Manufacturer: Custom Metal Fabricated
 Model Number: Custom, as per plans and details.
 Dimensions: 2'-6" x 15'-2" x 8'-9" x 2'-6", as per plan from base to ceiling (approximately 10'-0"H). Verify with field measurements.
 Utility Requirements: None
 Accessories: A) Provide 20 gauge stainless steel wall flashing from base to ceiling a.f.f., from left side return, across full width of two dish room walls to return at end of dish table, as per plan.
 Installation Instructions: A) Securely mount to wall with high temperature construction adhesive. Seal all penetrations.

ITEM #K-60

SPARE NUMBER

ITEM #K-61

SPARE NUMBER

ITEM #K-62

STAINLESS STEEL CLEAN DISH TABLE

Quantity: (1) each
 Manufacturer: Custom Metal Fabricated.
 Model Number: Custom.
 Dimensions: 6'-0"W x 2'-6"D x 34"H
 Utility Requirements: None
 Accessories: A) 8" back and side splash.
 B) Provide 4'-0"W under shelf as per plan.
 Installation Instructions: A) Set and level as per plan.
 B) Clip and seal back splash to wall.
 C) Verify entry requirements of dishwasher. Gently slope table back to dishwasher.

ITEM #K-63

STAINLESS STEEL WALL SHELF

Quantity: (1) each
 Manufacturer: Custom Metal Fabricated
 Model Number: Custom, as per plans and details.
 Dimensions: 4'-9"W x 1'-2"D
 Utility Requirements: None
 Accessories: A) Provide with (2) mounting brackets.
 Installation Instructions: A) Mount to wall at +60" a.f.f., as per plan.
 B) General Contractor to provide blocking as required.

ITEM #K-64

STAINLESS STEEL FOUR COMPARTMENT SINK

Quantity:	(1) each
Manufacturer:	Custom Metal Fabricated
Model #:	Custom, as per plans and details.
Dimensions:	9'-8"W x 30"D x 37"H
Utility Requirements:	A) 1/2" hot and cold water. B) 1-1/2" indirect drain.
Accessories:	A) 8"H back and side splash. B) (1) each 14" swing faucets. C) (3) each lever operated drain with built in overflow. D) (2) each faucet knock outs. E) Sink compartments to be 18"W x 24"D. F) 18" Drain board on each side.
Installation Instructions:	A) Set and level as per plan. B) Clip and seal back splash to wall.

ITEM #K-65

DISPOSER

Quantity:	(1) each
Manufacturer:	Salvajor
Model Number:	#150-CA-ARSS-(208/60/3)
Dimensions:	13"Diameter x 19"H
Utility Requirements:	A) 1/2" Cold water. B) 2" Direct drain. C) 208/60/3, 1-1/2 HP
Accessories:	A) 3-1/2" Sink Assembly. D) Pre-wired control panel, mounted to Four Compartment Sink, item #K-64. E) Short body to allow for mounting under sink compartment.
Installation Instructions:	A) Mount to left compartment of Four Compartment Sink, item #K-64. B) Verify fit under sink.

ITEM #K-66

PRE-RINSE SPRAY

Quantity:	(1) each
Manufacturer:	T&S Brass
Model Number:	#B-0163/B-0107
Dimensions:	33"H
Utility Requirements:	A) 1/2" hot and cold water.
Accessories:	A) Provide wall bracket. B) Splash Mount. C) Provide with B-0107 Spray Valve. D) Provide with add on 14" swing faucet
Installation Instructions:	A) Mount to Four Compartment Sink, item #K-64, as per plan.

ITEM #K-67

STAINLESS STEEL WALL SHELF

Quantity: (1) each
 Manufacturer: Custom Metal Fabricated
 Model Number: Custom, as per plans and details.
 Dimensions: (2) Sections, 2'-9"W and 5'-11"W x 14"D
 Utility Requirements: None
 Accessories: A) Provide with (4) mounting brackets.
 Installation Instructions: A) Mount level to wall at +66" a.f.f. (Verify with User) to top of unit shelf as per plan.
 B) Provide 12" gap at Pre-Rinse, item #K66.
 B) General Contractor to provide wall blocking as required.

ITEM #K-68

STAINLESS STEEL WALL FLASHING

Quantity: (1) lot
 Manufacturer: Custom Metal Fabricated
 Model Number: Custom, as per plans and details.
 Dimensions: 9'-8" x 6'-4" "L" to Ceiling, as per plan.
 Utility Requirements: None
 Accessories: A) Provide 20 gauge stainless steel wall flashing on pot sink back wall and side wall to clean dish table, from floor base to ceiling. Provide stainless steel "J" and "T" trim at seams and at top edge.
 Installation Instructions: A) Securely mount to wall with high temperature construction adhesive. Seal all penetrations.

ITEM #K-69

HOSE REEL

Quantity: (1) each
 Manufacturer: T&S Brass
 Model Number: #B-1444-CV
 Dimensions: Verify
 Utility Requirements: A) 1/2" Hot & Cold Water.
 Accessories: A) Concealed Installation.
 B) Retractable Reel.
 C) Provide with continuous pressure back flow preventers.
 D) Shut off valve.
 E) 50' of hose.
 F) High pressure trigger gun spray #MV-2522.
 G) Stainless steel enclosure
 Installation Instructions: A) Mount to wall and to underside of right drain board of pot sink, item #K-64. Verify height at top to be approximately 30" a.f.f.
 B) Plumbing Contractor to install mixing valve concealed in accessible adjacent wall.

ITEM #E-01

BASE OFFICE COMPUTER: PROVIDED BY OWNER

Quantity: (1) each

ITEM #E-02

CASHIER REGISTER COMPUTER: PROVIDED BY OWNER

Quantity: (1) each

END OF SECTION

INDEX

SECTION	TITLE
PLUMBING	
22 0500	COMMON WORK RESULTS FOR PLUMBING
22 0519	METERS AND GAGES FOR PLUMBING PIPING
22 0529	HANGERS AND SUPPORTS FOR PLUMBING PIPING AND EQUIPMENT
22 0553	IDENTIFICATION FOR PLUMBING PIPING
22 0700	PLUMBING INSULATION
22 1116	DOMESTIC WATER PIPING
22 1119	DOMESTIC WATER PIPING SPECIALTIES
22 1316	STORM, SANITARY WASTE AND VENT PIPING
22 1319	SANITARY WASTE PIPING SPECIALTIES
22 4000	PLUMBING FIXTURES
MECHANICAL	
23 0500	COMMON WORK RESULTS FOR HVAC
23 0548	VIBRATION AND SEISMIC CONTROLS FOR HVAC PIPING AND EQUIPMENT
23 0553	IDENTIFICATION FOR HVAC PIPING AND EQUIPMENT
23 0593	TESTING, ADJUSTING, AND BALANCING FOR HVAC
23 0700	HVAC INSULATION
23 0900	INSTRUMENTATION AND CONTROL FOR HVAC
23 1123	FACILITY NATURAL-GAS PIPING
23 2300	REFRIGERANT PIPING
23 3113	METAL DUCTS
23 3300	AIR DUCT ACCESSORIES
23 3423	HVAC POWER VENTILATORS
23 7433	PACKAGED, OUTDOOR, MAKEUP AIR-UNITS
23 8126	INTERIOR VRF UNITS
23 8146	AIR COOLED UNITARY HEAT PUMPS

SECTION 22 0500 - COMMON WORK RESULTS FOR PLUMBING**PART 1 - GENERAL****1.1 SUMMARY**

A. This Section includes the following:

1. Piping materials and installation instructions common to most piping systems.
2. Dielectric fittings.
3. Selective Plumbing Demolition
4. Supports and anchorages.

1.2 SUBMITTALS

A. Welding certificates.

1.3 QUALITY ASSURANCE

A. Steel Support Welding: Qualify processes and operators according to AWS D1.1, "Structural Welding Code--Steel."

PART 2 - PRODUCTS**2.1 PIPE, TUBE, AND FITTINGS**

- A. Refer to individual Division 22 piping Sections for pipe, tube, and fitting materials and joining methods.
- B. Pipe Threads: ASME B1.20.1 for factory-threaded pipe and pipe fittings.

2.2 JOINING MATERIALS

- A. Refer to individual Division 22 piping Sections for special joining materials not listed below.
- B. Solder Filler Metals: ASTM B 32, lead-free alloys. Include water-flushable flux according to ASTM B 813.
- C. Brazing Filler Metals: AWS A5.8, BCuP Series or BAg1, unless otherwise indicated.
- D. Welding Filler Metals: Comply with AWS D10.12.

2.3 DIELECTRIC FITTINGS

- A. Description: Combination fitting of copper alloy and ferrous materials with threaded, solder-joint, plain, or weld-neck end connections that match piping system materials.

2.4 ESCUTCHEONS

- A. Description: Manufactured wall and ceiling escutcheons and floor plates, with an ID to closely fit around pipe, tube, and insulation of insulated piping and an OD that completely covers opening.
- B. One-Piece, Deep-Pattern or Flat Face Type: Deep-drawn brass with polished chrome-plated finish.

PART 3 - EXECUTION

3.1 PLUMBING DEMOLITION

- A. Disconnect, demolish, and remove plumbing systems, equipment, and components indicated to be removed.
 - 1. Piping to Be Removed: Remove portion of piping indicated to be removed and cap or plug remaining piping with same or compatible piping material.
 - 2. Piping to Be Abandoned in Place: Drain piping and cap or plug piping with same or compatible piping material.
- B. If pipe, insulation, or equipment to remain is damaged in appearance or is unserviceable, remove damaged or unserviceable portions and replace with new products of equal capacity and quality.

3.2 PIPING SYSTEMS - COMMON REQUIREMENTS

- A. Install piping according to the following requirements and Division 22 Sections specifying piping systems.
- B. Make connections to existing piping systems where indicated. Field verify locations of required connections to existing piping systems or services prior to removing ceiling systems.
- C. Drawing plans, schematics, and diagrams indicate general location and arrangement of piping systems. Indicated locations and arrangements were used to size pipe and calculate friction loss, expansion, pump sizing, and other design considerations. Install piping as indicated unless deviations to layout are approved on Coordination Drawings.
- D. Install piping in concealed locations, unless otherwise indicated and except in equipment rooms and service areas.
- E. Install piping indicated to be exposed and piping in equipment rooms and service areas at right angles or parallel to building walls. Diagonal runs are prohibited unless specifically indicated otherwise.

- F. Install piping above accessible ceilings to allow sufficient space for ceiling panel removal.
- G. Install piping to permit valve servicing.
- H. Install piping at indicated slopes.
- I. Install piping free of sags and bends.
- J. Install fittings for changes in direction and branch connections.
- K. Install piping to allow application of insulation.
- L. Select system components with pressure rating equal to or greater than system operating pressure.
- M. Install escutcheons for penetrations of finished walls, ceilings, and floors.
- N. Install sleeves for pipes passing through concrete and masonry walls, gypsum-board partitions, and concrete floor and roof slabs.
- O. Verify final equipment locations for roughing-in.
- P. Refer to equipment specifications in other Sections of these Specifications for roughing-in requirements.

3.3 PIPING JOINT CONSTRUCTION

- A. Join pipe and fittings according to the following requirements and Division 22 Sections specifying piping systems.
- B. Ream ends of pipes and tubes and remove burrs. Bevel plain ends of steel pipe.
- C. Remove scale, slag, dirt, and debris from inside and outside of pipe and fittings before assembly.
- D. Soldered Joints: Apply ASTM B 813, water-flushable flux, unless otherwise indicated, to tube end. Construct joints according to ASTM B 828 or CDA's "Copper Tube Handbook," using lead-free solder alloy complying with ASTM B 32.
- E. Brazed Joints: Construct joints according to AWS's "Brazing Handbook," "Pipe and Tube" Chapter, using copper-phosphorus brazing filler metal complying with AWS A5.8.
- F. Threaded Joints: Thread pipe with tapered pipe threads according to ASME B1.20.1. Cut threads full and clean using sharp dies. Ream threaded pipe ends to remove burrs and restore full ID. Join pipe fittings and valves as follows:
 - 1. Apply appropriate tape or thread compound to external pipe threads unless dry seal threading is specified.
 - 2. Damaged Threads: Do not use pipe or pipe fittings with threads that are corroded or damaged. Do not use pipe sections that have cracked or open welds.
- G. Welded Joints: Construct joints according to AWS D10.12, using qualified processes and welding operators according to Part 1 "Quality Assurance" Article.

H. Plastic Piping Solvent-Cement Joints: Clean and dry joining surfaces. Join pipe and fittings according to the following:

1. Comply with ASTM F 402, for safe-handling practice of cleaners, primers, and solvent cements.
2. PVC Nonpressure Piping: Join according to ASTM D 2855.

3.4 PIPING CONNECTIONS

A. Make connections according to the following, unless otherwise indicated:

1. Install unions, in piping NPS 2 and smaller, adjacent to each valve and at final connection to each piece of equipment.
2. Install flanges, in piping NPS 2-1/2 and larger, adjacent to flanged valves and at final connection to each piece of equipment.

END OF SECTION 22 0500

SECTION 22 0519 - METERS AND GAGES FOR PLUMBING PIPING

PART 1 - GENERAL

1.1 SUMMARY

- A. Section Includes:
 - 1. Thermometers.

1.2 SUBMITTALS

- A. Product Data: For each type of product indicated.

PART 2 - PRODUCTS

2.1 METAL-CASE, LIQUID-IN-GLASS THERMOMETERS

- A. Manufacturers: Subject to compliance with requirements, provide products by one of the following manufacturers:
 - 1. Palmer - Wahl Instruments Inc.
 - 2. Trerice, H. O. Co.
 - 3. Weiss Instruments, Inc.
 - 4. Weksler Instruments Operating Unit; Dresser Industries; Instrument Div.
- B. Case: Die-cast aluminum 7 inches long.
- C. Tube: Red or blue reading, organic-liquid filled, with magnifying lens.
- D. Tube Background: Satin-faced, nonreflective aluminum with permanently etched scale markings.
- E. Window: Glass
- F. Connector: Adjustable type, 180 degrees in vertical plane, 360 degrees in horizontal plane, with locking device.
- G. Stem: Copper-plated steel, aluminum, or brass for thermowell installation and of length to suit installation.
- H. Accuracy: Plus or minus 1 percent of range or plus or minus 1 scale division to maximum of 1.5 percent of range.

2.2 THERMOWELLS

- A. Manufacturers: Same as manufacturer of thermometer being used.

- B. Description: Pressure-tight, socket-type metal fitting made for insertion into piping and of type, diameter, and length required to hold thermometer.

PART 3 - EXECUTION

3.1 THERMOMETER APPLICATIONS

- A. Install liquid-in-glass thermometers above the isolation ball valve of each hot water system in the plumbing chase. Provide the following temperature ranges for thermometers:
 - 1. Domestic Hot Water: 30 to 180 deg F, with 2-degree scale divisions

3.2 INSTALLATIONS

- A. Install direct-mounting thermometers and adjust vertical and tilted positions.
- B. Install thermowells with socket extending a minimum of 2 inches into fluid pipe and in vertical position in piping tees where thermometers are indicated.
- C. Install thermometers and gages adjacent to machines and equipment to allow service and maintenance for thermometers, gages, machines, and equipment.
- D. Adjust faces of thermometers and gages to proper angle for best visibility.

END OF SECTION 22 0519

SECTION 22 0529 - HANGERS AND SUPPORTS FOR PLUMBING PIPING AND EQUIPMENT

PART 1 - GENERAL

1.1 SUMMARY

- A. This Section includes the following:
 - 1. Steel pipe hangers and supports.
 - 2. Thermal-hanger shield inserts.

1.2 DEFINITIONS

- A. Terminology: As defined in MSS SP-90, "Guidelines on Terminology for Pipe Hangers and Supports."

1.3 PERFORMANCE REQUIREMENTS

- A. Design supports for multiple pipes capable of supporting combined weight of supported systems, system contents, and test water.
- B. Design equipment supports capable of supporting combined operating weight of supported equipment and connected systems and components.

1.4 SUBMITTALS

- A. Product Data: For the following:
 - 1. Steel pipe hangers and supports.
 - 2. Thermal-hanger shield inserts.

1.5 QUALITY ASSURANCE

- A. Welding: Qualify procedures and personnel according to ASME Boiler and Pressure Vessel Code: Section IX.

PART 2 - PRODUCTS

2.1 STEEL PIPE HANGERS AND SUPPORTS

- A. Description: MSS SP-58, Types 1 through 58, factory-fabricated components. Refer to Part 3 "Hanger and Support Applications" Article for where to use specific hanger and support types.
- B. Manufacturers:
 - 1. B-Line Systems, Inc.; a division of Cooper Industries.

2. Globe Pipe Hanger Products, Inc.
 3. Grinnell Corp.
- C. Galvanized, Metallic Coatings: Pregalvanized or hot dipped.
- D. Nonmetallic Coatings: Plastic coating, jacket, or liner.
- E. Padded Hangers: Hanger with fiberglass or other pipe insulation pad or cushion for support of bearing surface of piping.

2.2 THERMAL-HANGER SHIELD INSERTS

- A. Description: 100-psig- minimum, compressive-strength insulation insert encased in sheet metal shield.

PART 3 - EXECUTION

3.1 HANGER AND SUPPORT APPLICATIONS

- A. Specific hanger and support requirements are specified in Sections specifying piping systems and equipment. Comply with MSS SP-69 for pipe hanger selections and applications that are not specified in piping system Sections.
- B. Use hangers and supports with galvanized, metallic coatings for piping and equipment that will not have field-applied finish.
- C. Use nonmetallic coatings on attachments for electrolytic protection where attachments are in direct contact with copper tubing.
- D. Horizontal-Piping Hangers and Supports: Unless otherwise indicated and except as specified in piping system Sections, install the following types:
1. Adjustable, Steel Clevis Hangers: For suspension of non-insulated or insulated stationary pipes, NPS 1/2 to NPS 6
- E. Vertical-Piping Clamps: Unless otherwise indicated and except as specified in piping system Sections, install the following types:
1. Extension Pipe or Riser Clamps: For support of pipe risers, NPS 3/4 to NPS 6.
- F. Hanger-Rod Attachments: Unless otherwise indicated and except as specified in piping system Sections, install the following types:
1. Steel Turnbuckles: For adjustment up to 6 inches for heavy loads.
- G. Building Attachments: Unless otherwise indicated and except as specified in piping system Sections, install the following types:
1. Steel or Malleable Concrete Inserts: For upper attachment to suspend pipe hangers from concrete ceiling.

2. Top-Beam C-Clamps: For use under roof installations with bar-joist construction to attach to top flange of structural shape.
 3. Side-Beam or Channel Clamp: For attaching to bottom flange of beams, channels, or angles.
 4. Center-Beam Clamps: For attaching to center of bottom flange of beams.
 5. Welded Beam Attachments: For attaching to bottom of beams if loads are considerable and rod sizes are large.
 6. C-Clamps: For structural shapes.
 7. Welded-Steel Brackets: For support of pipes from below, or for suspending from above by using clip and rod. Use one of the following for indicated loads:
 - a. Light: 750 lb
 8. Side-Beam Brackets: For sides of steel or wooden beams.
 9. Plate Lugs: For attaching to steel beams if flexibility at beam is required.
- H. Saddles and Shields: Unless otherwise indicated and except as specified in piping system Sections, install the following types:
1. Steel Pipe-Covering Protection Saddles (MSS Type 39): To fill interior voids with insulation that matches adjoining insulation.
 2. Protection Shields (MSS Type 40): Of length recommended in writing by manufacturer to prevent crushing insulation.
 3. Thermal-Hanger Shield Inserts: For supporting insulated pipe.
- I. Comply with MFMA-102 for metal framing system selections and applications that are not specified in piping system Sections.
- J. Use powder-actuated fasteners of building attachments where required in concrete construction.
- K. Provide non conductive saddles, shields or inserts to prevent galvanic action between bare un-insulated piping and clevis hangers.

3.2 HANGER AND SUPPORT INSTALLATION

- A. Steel Pipe Hanger Installation: Comply with MSS SP-69 and MSS SP-89. Install hangers, supports, clamps, and attachments as required to properly support piping from building structure.
- B. Install hangers and supports complete with necessary inserts, bolts, rods, nuts, washers, and other accessories.
- C. Equipment Support Installation: Fabricate from welded-structural-steel shapes.
- D. Install hangers and supports to allow controlled thermal and seismic movement of piping systems, to permit freedom of movement between pipe anchors, and to facilitate action of expansion joints, expansion loops, expansion bends, and similar units.
- E. Install lateral bracing with pipe hangers and supports to prevent swaying.

- F. Install building attachments within concrete slabs or attach to structural steel. Install additional attachments at concentrated loads, including valves, flanges, and strainers, NPS 2-1/2 and larger and at changes in direction of piping.
- G. Load Distribution: Install hangers and supports so piping live and dead loads and stresses from movement will not be transmitted to connected equipment.
- H. Pipe Slopes: Install hangers and supports to provide indicated pipe slopes and so maximum pipe deflections allowed by ASME B31.9 for building services piping are not exceeded.
- I. Insulated Piping: Comply with the following:
 - 1. Attach clamps and spacers to piping.
 - a. Piping Operating above Ambient Air Temperature: Clamp may project through insulation.
 - b. Piping Operating below Ambient Air Temperature: Use thermal-hanger shield insert with clamp sized to match OD of insert.
 - c. Do not exceed pipe stress limits according to ASME B31.9 for building services piping.
 - 2. Install MSS SP-58, Type 39, protection saddles if insulation without vapor barrier is indicated. Fill interior voids with insulation that matches adjoining insulation.
 - 3. Thermal-Hanger Shields: Install with insulation same thickness as piping insulation.

3.3 ADJUSTING

- A. Hanger Adjustments: Adjust hangers to distribute loads equally on attachments and to achieve indicated slope of pipe. Where pipe slope is not indicated, adjust hangers to allow piping to drain.

END OF SECTION 22 0529

SECTION 22 0553 - IDENTIFICATION FOR PLUMBING PIPING**PART 1 - GENERAL****1.1 SUMMARY**

- A. Section Includes:
1. Pipe labels.

1.2 SUBMITTAL

Submittal in this article is defined in Division 01 Section "Submittal Procedures" as an "Action Submittal."

- A. Product Data: For each type of product indicated.

PART 2 - PRODUCTS**2.1 PIPE LABELS**

- A. General Requirements for Manufactured Pipe Labels: Preprinted, color-coded, with lettering indicating service, and showing flow direction.
- B. Self-Adhesive Pipe Labels: Printed plastic with contact-type, permanent-adhesive backing.
- C. Pipe Label Contents: Include identification of piping service using same designations or abbreviations as used on Drawings, pipe size, and an arrow indicating flow direction.
1. Flow-Direction Arrows: Integral with piping system service lettering to accommodate both directions, or as separate unit on each pipe label to indicate flow direction.
 2. Lettering Size: At least 1-1/2 inches high.

PART 3 - EXECUTION**3.1 PIPE LABEL INSTALLATION**

- A. Locate pipe labels where piping is exposed or above accessible ceilings in finished spaces; machine rooms; accessible maintenance spaces such as plenums as follows:
1. Near each valve and control device.
 2. Near each branch connection, excluding short takeoffs for fixtures and terminal units. Where flow pattern is not obvious, mark each pipe at branch.
 3. Near penetrations through walls, floors, ceilings, and inaccessible enclosures.
 4. Near major equipment items and other points of origination and termination.
 5. Spaced at maximum intervals of 50 feet along each run.
 6. On piping above removable acoustical ceilings.
- B. Pipe Label Color Schedule:

1. Domestic Water Piping:
 - a. Background Color: Green
 - b. Letter Color: White
2. Natural Gas Piping:
 - a. Background Color: Yellow
 - b. Letter Color: Black

END OF SECTION 22 0553

SECTION 22 0700 - PLUMBING INSULATION**PART 1 - GENERAL****1.1 SUMMARY**

- A. Section Includes:
1. Insulation Materials:
 - a. Mineral fiber.
 2. Insulating cements.
 3. Adhesives.
 4. Mastics.

1.2 SUBMITTALS

- A. Product Data: For each type of product indicated.

1.3 QUALITY ASSURANCE

- A. Fire-Test-Response Characteristics: Insulation and related materials shall have fire-test-response characteristics indicated, as determined by testing identical products per ASTM E 84, by a testing and inspecting agency acceptable to authorities having jurisdiction. Factory label insulation and jacket materials and adhesive, mastic, tapes, and cement material containers, with appropriate markings of applicable testing and inspecting agency.
1. Insulation Installed Indoors: Flame-spread index of 25 or less, and smoke-developed index of 50 or less.

PART 2 - PRODUCTS**2.1 INSULATION MATERIALS**

- A. Mineral-Fiber, Preformed Pipe Insulation:
1. Products: Subject to compliance with requirements, provide one of the following:
 - a. Fibrex Insulations Inc.; Coreplus 1200.
 - b. Johns Manville; Micro-Lok.
 - c. Knauf Insulation; 1000 Pipe Insulation.
 - d. Manson Insulation Inc.; Alley-K.
 - e. Owens Corning; Fiberglas Pipe Insulation.
 2. Type I, 850 deg F Materials: Mineral or glass fibers bonded with a thermosetting resin. Comply with ASTM C 547, Type I, Grade A, with factory-applied ASJ. .

2.2 INSULATING CEMENTS

- A. Mineral-Fiber, Hydraulic-Setting Insulating and Finishing Cement: Comply with ASTM C 449/C 449M.

2.3 ADHESIVES

- A. Materials shall be compatible with insulation materials, jackets, and substrates and for bonding insulation to itself and to surfaces to be insulated, unless otherwise indicated.
- B. Mineral-Fiber Adhesive: Comply with MIL-A-3316C, Class 2, Grade A.
 - 1. For indoor applications, use adhesive that has a VOC content of 80 g/L or less when calculated according to 40 CFR 59, Subpart D (EPA Method 24).

2.4 MASTICS

- A. Materials shall be compatible with insulation materials, jackets, and substrates; comply with MIL-C-19565C, Type II.
 - 1. For indoor applications, use mastics that have a VOC content calculated according to 40 CFR 59, Subpart D (EPA Method 24).

2.5 FACTORY-APPLIED JACKETS

- A. Insulation system schedules indicate factory-applied jackets on various applications. When factory-applied jackets are indicated, comply with the following:
 - 1. ASJ: White, kraft-paper, fiberglass-reinforced scrim with aluminum-foil backing; complying with ASTM C 1136, Type I.
- B. PVC Jacket and Fitting Covers: High-impact-resistant, UV-resistant PVC complying with ASTM D 1784, Class 16354-C; roll stock ready for shop or field cutting and forming.
 - 1. Products: Subject to compliance with requirements, provide one of the following:
 - a. Johns Manville; Zeston.
 - b. P.I.C. Plastics, Inc.; FG Series.
 - c. Proto PVC Corporation; LoSmoke.
 - d. Speedline Corporation; SmokeSafe.
 - 2. Adhesive: As recommended by jacket material manufacturer.
 - 3. Color: White
 - 4. Factory-fabricated fitting covers:
 - a. Shapes: 45- and 90-degree, short- and long-radius elbows, tees, valves, flanges, unions, reducers, end caps, soil-pipe hubs, traps, mechanical joints, and P-trap and supply covers for lavatories.

2.6 TAPES

- A. ASJ Tape: White vapor-retarder tape matching factory-applied jacket with acrylic adhesive, complying with ASTM C 1136.

PART 3 - EXECUTION

3.1 GENERAL INSTALLATION REQUIREMENTS

- A. Install insulation materials, accessories, and finishes with smooth, straight, and even surfaces; free of voids throughout the length of equipment and piping including fittings, valves, and specialties.
- B. Install accessories compatible with insulation materials and suitable for the service. Install accessories that do not corrode, soften, or otherwise attack insulation or jacket in either wet or dry state.
- C. Install insulation with longitudinal seams at top and bottom of horizontal runs.
- D. Install multiple layers of insulation with longitudinal and end seams staggered.
- E. Install insulation with tight longitudinal seams and end joints. Bond seams and joints with adhesive recommended by insulation material manufacturer.
- F. Install insulation with least number of joints practical.
- G. Apply adhesives, mastics, and sealants at manufacturer's recommended coverage rate and wet and dry film thicknesses.
- H. Cut insulation in a manner to avoid compressing insulation more than 75 percent of its nominal thickness.
- I. Finish installation with systems at operating conditions. Repair joint separations and cracking due to thermal movement.
- J. Install PVC Jacket covers at all elbows, tees, valves, unions, reducers and other areas where insulated piping is exposed.
- K. Install PVC pipe jacket on all piping subject to water damage or in wet areas.
- L. Repair damaged insulation facings by applying same facing material over damaged areas. Extend patches at least 4 inches beyond damaged areas. Adhere, staple, and seal patches similar to butt joints.

3.2 PENETRATIONS

- A. Insulation Installation at Aboveground Exterior Wall Penetrations: Install insulation continuously through wall penetrations.
 - 1. Seal penetrations with flashing sealant.

2. For applications requiring only indoor insulation, terminate insulation inside wall surface and seal with joint sealant. For applications requiring indoor and outdoor insulation, install insulation for outdoor applications tightly joined to indoor insulation ends. Seal joint with joint sealant.
3. Seal jacket to wall flashing with flashing sealant.

- B. Insulation Installation at Interior Wall and Partition Penetrations (That Are Not Fire Rated): Install insulation continuously through walls and partitions.

3.3 GENERAL PIPE INSULATION INSTALLATION

- A. Insulation Installation on Fittings, Valves, Strainers, Flanges, and Unions:

1. Install insulation over fittings, valves, strainers, flanges, unions, and other specialties with continuous thermal and vapor-retarder integrity, unless otherwise indicated.
2. Insulate pipe elbows using preformed fitting insulation or mitered fittings made from same material and density as adjacent pipe insulation. Each piece shall be butted tightly against adjoining piece and bonded with adhesive. Fill joints, seams, voids, and irregular surfaces with insulating cement finished to a smooth, hard, and uniform contour that is uniform with adjoining pipe insulation. Cover with PVC Jacket.
3. Insulate tee fittings with preformed fitting insulation or sectional pipe insulation of same material and thickness as used for adjacent pipe. Cut sectional pipe insulation to fit. Butt each section closely to the next and hold in place with tie wire. Bond pieces with adhesive. Cover with PVC Jacket.
4. Insulate valves using preformed fitting insulation or sectional pipe insulation of same material, density, and thickness as used for adjacent pipe. Overlap adjoining pipe insulation by not less than two times the thickness of pipe insulation, or one pipe diameter, whichever is thicker. For valves, insulate up to and including the bonnets, valve stuffing-box studs, bolts, and nuts. Fill joints, seams, and irregular surfaces with insulating cement. Cover with PVC Jacket.
5. Insulate strainers using preformed fitting insulation or sectional pipe insulation of same material, density, and thickness as used for adjacent pipe. Overlap adjoining pipe insulation by not less than two times the thickness of pipe insulation, or one pipe diameter, whichever is thicker. Fill joints, seams, and irregular surfaces with insulating cement. Insulate strainers so strainer basket flange or plug can be easily removed and replaced without damaging the insulation and jacket. Provide a removable reusable insulation cover.
6. Insulate flanges and unions using a section of oversized preformed pipe insulation. Overlap adjoining pipe insulation by not less than two times the thickness of pipe insulation, or one pipe diameter, whichever is thicker.
7. Cover segmented insulated surfaces with a layer of finishing cement and coat with a mastic. Install vapor-barrier mastic for below ambient services and a breather mastic for above ambient services. Reinforce the mastic with fabric-reinforcing mesh. Trowel the mastic to a smooth and well-shaped contour.

- B. Insulate instrument connections for thermometers, pressure gages, pressure temperature taps, test connections, flow meters, sensors, switches, and transmitters on insulated pipes, vessels, and equipment. Shape insulation at these connections by tapering it to and around the connection with insulating cement and finish with finishing cement, mastic, and flashing sealant.

3.4 MINERAL-FIBER INSULATION INSTALLATION

A. Insulation Installation on Straight Pipes and Tubes:

1. Secure each layer of preformed pipe insulation to pipe with wire or bands and tighten bands without deforming insulation materials.
2. Seal longitudinal seams, end joints, and protrusions with vapor-barrier mastic and joint sealant.
3. For insulation with factory-applied jackets on above ambient surfaces, secure laps with outward clinched staples at 6 inches o.c.
4. For insulation with factory-applied jackets on below ambient surfaces, do not staple longitudinal tabs but secure tabs with additional adhesive as recommended by insulation material manufacturer and seal with vapor-barrier mastic and flashing sealant.

B. Insulation Installation on Pipe Fittings and Elbows:

1. Install preformed sections of same material as straight segments of pipe insulation when available.
2. When preformed insulation elbows and fittings are not available, install mitered sections of pipe insulation, to a thickness equal to adjoining pipe insulation. Secure insulation materials with wire or bands.

C. Insulation Installation on Valves and Pipe Specialties:

1. Install preformed sections of same material as straight segments of pipe insulation when available.
2. When preformed sections are not available, install mitered sections of pipe insulation to valve body.
3. Arrange insulation to permit access to packing and to allow valve operation without disturbing insulation.
4. Install insulation to flanges as specified for flange insulation application.

3.5 INDOOR PIPING INSULATION SCHEDULE

A. Domestic Hot and Re-circulated Hot Water: Insulation shall be the following:

1. Mineral-Fiber, Preformed Pipe Insulation, Type I with ASJ: 1 inch thick.

B. Domestic Cold Water: Insulation shall be the following:

1. Mineral-Fiber, Preformed Pipe Insulation, Type I with ASJ: 1 inch thick.

END OF SECTION 22 0700

SECTION 22 1116 - DOMESTIC WATER PIPING**PART 1 - GENERAL****1.1 SUMMARY****A. Section Includes:**

1. Aboveground domestic water pipes, tubes, fittings, and specialties inside the building.
2. Escutcheons.

1.2 PERFORMANCE REQUIREMENTS

- A. Seismic Performance: Domestic water piping and support and installation shall withstand effects of earthquake motions determined according to ASCE/SEI 7

1.3 SUBMITTALS

- A. Product Data: For each type of product indicated.

1.4 QUALITY ASSURANCE

- A. Domestic Made Copper Pipe Only.
- B. Piping materials shall bear label, stamp, or other markings of specified testing agency.

PART 2 - PRODUCTS**2.1 COPPER TUBE AND FITTINGS**

- A. Hard Copper Tube: ASTM B 88, Type L water tube, drawn temper.
1. Wrought-Copper Solder-Joint Fittings: ASME B16.22, wrought-copper pressure fittings.
 2. Copper Unions: MSS SP-123, cast-copper-alloy, hexagonal-stock body, with ball-and-socket, metal-to-metal seating surfaces, and solder-joint or threaded ends.

2.2 PIPING JOINING MATERIALS

- A. Solder Filler Metals: ASTM B 32, lead-free alloys. Include water-flushable flux according to ASTM B 813.
- B. Brazing Filler Metals: AWS A5.8/A5.8M, BCuP Series, copper-phosphorus alloys for general-duty brazing unless otherwise indicated.

2.3 TRANSITION FITTINGS

- A. Fitting-Type Transition Couplings: Manufactured piping coupling or specified piping system fitting.

2.4 DIELECTRIC FITTINGS

- A. General Requirements: Assembly of copper alloy and ferrous materials or ferrous material body with separating nonconductive insulating material suitable for system fluid, pressure, and temperature.

2.5 ESCUTCHEONS

- A. General: Manufactured chrome plated brass or polished stainless steel ceiling, floor, and wall escutcheons and floor plates.

PART 3 - EXECUTION

3.1 PIPING INSTALLATION

- A. Drawing plans, schematics, and diagrams indicate general location and arrangement of domestic water piping. Indicated locations and arrangements are used to size pipe and calculate friction loss, expansion, and other design considerations. Install piping as indicated unless deviations to layout are approved.
- B. Make connections to existing water piping systems as indicated on the drawings or as required to provide for a complete and ample supply of hot and cold domestic water to all plumbing fixtures and equipment indicated. Provide isolation ball valves at each point of connection (P.O.C.). Provide di-electric unions at each P.O.C. where dissimilar piping materials exist.
- C. Install shutoff valves at each branch connection. In plumbing chases, provide readily accessible isolation valves at 48-60 inches above the finished floor. Valves shall provide isolation of sets or groups of plumbing fixtures.
- D. Install thermometer on inlet and outlet of water heaters.
- E. Install domestic water piping sloped downward toward drain.
- F. Install seismic restraints on piping.
- G. Install piping concealed from view and protected from physical contact by building occupants unless otherwise indicated and except in equipment rooms and service areas. Install piping at right angles or parallel to building walls. Diagonal runs are prohibited unless specifically indicated otherwise.
- H. Install piping above accessible ceilings to allow sufficient space for ceiling panel removal, and coordinated with other services and trades, including mechanical and electrical, occupying that space.
- I. Install piping adjacent to equipment and specialties to allow service and maintenance. Install piping to permit valve servicing.

- J. Install nipples, unions, di-electric unions, special fittings, and valves with pressure ratings the same as or higher than system pressure rating used in applications below unless otherwise indicated.
- K. Install piping free of sags and bends. Install fittings for changes in direction and branch connections.
- L. Install unions in copper tubing at final connection to each piece of equipment, machine, and specialty.
- M. Install thermometers in hot-water piping where indicated.

3.2 JOINT CONSTRUCTION

- A. Ream ends of pipes and tubes and remove burrs. Bevel plain ends of steel pipe. Remove scale, slag, dirt, and debris from inside and outside of pipes, tubes, and fittings before assembly.
- B. Brazed Joints: Join copper tube and fittings according to CDA's "Copper Tube Handbook," "Braze Joints" Chapter.
- C. Soldered Joints: Apply ASTM B 813, water-flushable flux to end of tube. Join copper tube and fittings according to ASTM B 828 or CDA's "Copper Tube Handbook."

3.3 VALVE INSTALLATION

- A. Install shutoff valve on each branch serving plumbing fixtures or equipment, on each water supply to equipment.
- B. Install drain valves for equipment at base of each water riser, at low points in horizontal piping, and where required to drain water piping.

3.4 DIELECTRIC FITTING INSTALLATION

- A. Install dielectric fittings in piping at connections of dissimilar metal piping and tubing.

3.5 HANGER AND SUPPORT INSTALLATION

- A. Support piping and tubing according to MSS SP-69 and manufacturer's written instructions.
- B. Comply with requirements in Division 22 Section "Hangers and Supports for Plumbing Piping and Equipment" for pipe hanger and support products and installation.
 - 1. Vertical Piping: MSS Type 8 or 42, clamps.
 - 2. Individual, Straight, Horizontal Piping Runs:
 - a. 100 Feet and Less: MSS Type 1, adjustable, steel clevis hangers.
 - 3. Base of Vertical Piping: MSS Type 52, spring hangers.
- C. Support vertical piping and tubing at base and at each floor.

- D. Rod diameter may be reduced one size for double-rod hangers, to a minimum of 3/8 inch
- E. Install supports for vertical copper tubing every 10 feet

3.6 CONNECTIONS

- A. Drawings indicate general arrangement of piping, fittings, and specialties.
- B. Install piping adjacent to equipment and machines to allow service and maintenance.
- C. Install isolation valves adjacent to each piece of equipment or appliance to allow service and maintenance.
- D. Connect domestic water piping to water-service piping with shutoff valve; extend and connect to the following:
 - 1. Plumbing Fixtures: Cold- and hot-water supply piping in sizes indicated, but not smaller than required by plumbing code.
 - 2. Install ASSE 1070 tempering valves or mixing valves to mix hot water and cold water to provide tempered warm water to all public sinks and lavatories indicated.

3.7 ESCUTCHEON INSTALLATION

- A. Install chrome plated brass or polished stainless steel escutcheons for penetrations of all finished walls, ceilings, and floors. Provide escutcheons for penetrations of plumbing piping in cabinetry.

3.8 SLEEVE INSTALLATION

- A. General Requirements: Install sleeves for pipes and tubes passing through penetrations in floors, partitions, roofs, and walls.
- B. Fire-Barrier Penetrations: Maintain indicated fire rating of walls, partitions, ceilings, and floors at pipe penetrations. Seal pipe penetrations with firestop materials.

3.9 FIELD QUALITY CONTROL

- A. Perform tests and inspections.
- B. Piping Inspections:
 - 1. Do not enclose, cover, or put piping into operation until it has been inspected and approved by authorities having jurisdiction.
 - 2. During installation, notify authorities having jurisdiction at least one day before inspection must be made. Perform tests specified below in presence of authorities having jurisdiction:
 - a. Roughing-in Inspection: Arrange for inspection of piping before concealing or closing-in after roughing-in and before setting fixtures.
 - b. Final Inspection: Arrange final inspection for authorities having jurisdiction to observe tests specified below and to ensure compliance with requirements.

3. Reinspection: If authorities having jurisdiction find that piping will not pass tests or inspections, make required corrections and arrange for reinspection.
4. Reports: Prepare inspection reports and have them signed by authorities having jurisdiction.

C. Piping Tests:

1. Fill domestic water piping. Check components to determine that they are not air bound and that piping is full of water.
2. Test for leaks and defects in new piping and parts of existing piping that have been altered, extended, or repaired. If testing is performed in segments, submit a separate report for each test, complete with diagram of portion of piping tested.
3. Leave new, altered, extended, or replaced domestic water piping uncovered and unconcealed until it has been tested and approved. Expose work that was covered or concealed before it was tested.
4. Cap and subject piping to static water pressure of 50 psig above operating pressure, without exceeding pressure rating of piping system materials. Isolate test source and allow to stand for four hours. Leaks and loss in test pressure constitute defects that must be repaired.
5. Repair leaks and defects with new materials and retest piping or portion thereof until satisfactory results are obtained.
6. Prepare reports for tests and for corrective action required.

D. Domestic water piping will be considered defective if it does not pass tests and inspections.

E. Prepare test and inspection reports.

3.10 CLEANING

A. Clean and disinfect domestic water piping as follows:

1. Purge new piping and parts of existing piping that have been altered, extended, or repaired before using.
2. Use purging and disinfecting procedures prescribed by authorities having jurisdiction; if methods are not prescribed, use procedures described in either AWWA C651 or AWWA C652 or follow procedures described below:
 - a. Flush piping system with clean, potable water until dirty water does not appear at outlets.
 - b. Fill and isolate system according to either of the following:
 - 1) Fill system or part thereof with water/chlorine solution with at least 50 ppm of chlorine. Isolate with valves and allow to stand for 24 hours.
 - c. Flush system with clean, potable water until no chlorine is in water coming from system after the standing time.
 - d. Submit water samples in sterile bottles to authorities having jurisdiction. Repeat procedures if biological examination shows contamination.

B. Prepare and submit reports of purging and disinfecting activities.

C. Clean interior of domestic water piping system. Remove dirt and debris as work progresses.

END OF SECTION 22 1116

SECTION 22 1119 - DOMESTIC WATER PIPING SPECIALTIES

PART 1 - GENERAL

1.1 SUMMARY

- A. This Section includes the following domestic water piping specialties:

Adjust list below to suit Project.

1. Water hammer arresters.
2. Tempering Valves

1.2 SUBMITTALS

- A. Product Data: For each type of product indicated.

PART 2 - PRODUCTS

2.1 WATER HAMMER ARRESTERS

- A. Water Hammer Arresters:
1. Manufacturers: Subject to compliance with requirements, provide products by one of the following:
 - a. PPP Inc.
 - b. Smith, Jay R. Mfg. Co.; Division of Smith Industries, Inc.
 - c. Watts Drainage Products Inc.
 - d. Zurn Plumbing Products Group; Specification Drainage Operation.
 2. Standard: ASSE 1010 or PDI-WH 201.
 3. Size: ASSE 1010, Sizes AA and A through F or PDI-WH 201, Sizes A through F.

2.2 TEMPERING VALVES

- A. Tempering Valves:
1. Manufacturers: Subject to compliance with requirements, provide products by one of the following:
 - a. Leonard.
 - b. Bradley
 - c. Watts Drainage Products Inc.
 - d. Zurn Plumbing Products Group
- B. Design Standard: Leonard Model TM-1520A-RF-STSTL-EXP-D high/low manifold.
1. Size: ASSE 1070, Sizes ½ through 2 inch.

PART 3 - EXECUTION

3.1 INSTALLATION

- A. Install water hammer arresters in water piping according to PDI-WH 201 and where indicated on the drawings.
- B. Install water hammer arrestors where indicated and in each bank or set of water closets and urinals using snap acting flush valves.
- C. Install ASSE 1070 mixing valves below each individual lavatory. Set discharge temperature to 110 degrees F

END OF SECTION 22 1119

SECTION 22 1316 – STORM, SANITARY WASTE AND VENT PIPING

PART 1 - GENERAL

1.1 SUMMARY

- A. This Section includes the following soil and waste, sanitary drainage and vent piping inside the building:
 - 1. Pipe, tube, and fittings.
 - 2. Make connections to Storm, Sanitary Waste and Vent Piping installed under slab or in crawl space as indicated or as required.

1.2 PERFORMANCE REQUIREMENTS

- A. Components and installation shall be capable of withstanding the following minimum working pressure, unless otherwise indicated:
 - 1. Soil, Waste, and Vent Piping: 10-foot head of water

1.3 QUALITY ASSURANCE

- A. Piping materials shall bear label, stamp, or other markings of specified testing agency.

PART 2 - PRODUCTS

2.1 PIPING MATERIALS

- A. Sanitary Waste and Vent Piping Systems - Above Grade:

ABS Schedule 40 solid-wall ASTM D 2661, plastic pipe and socket type fittings, made to ASTM D 3311, drain, waste, and vent patterns. Joined using pipe cement meeting requirements of ASTM 2235.

Dishwasher Waste Piping - Crawl Space. Service weight, no-hub type cast iron soil pipe and fittings meeting requirements of ASTM A 74 with neoprene gaskets with type 304 and 24 ga type 304 stainless steel clamps. Minimum of 4 clamps.

Prep and Wash Sink Indirect Waste - PVC Schedule 40 solid-wall ASTM D 2665, plastic pipe and socket type fittings, made to ASTM D 3311, drain, waste, and vent patterns. Joined using cement primer meeting requirements of ASTM F 656 and pipe cement meeting requirements of ASTM D 2564.

PART 3 - EXECUTION

3.1 PIPING APPLICATIONS

- A. Special pipe fittings with pressure ratings at least equal to piping pressure ratings may be used in applications below, unless otherwise indicated.
- B. Flanges and unions may be used on aboveground pressure piping, unless otherwise indicated.
- C. Above Grade Storm, Sanitary Waste and Vent piping above grade shall be standard weight cast iron pipe with no-hub, gasketed fittings for sizes 2" and larger.
- D. Dishwasher Waste Piping - Crawl Space. Service weight, no-hub type cast iron soil pipe and fittings meeting requirements of ASTM A 74 with neoprene gaskets with type 304 and 24 ga type 304 stainless steel clamps. Minimum of 4 clamps.
- E. Prep and Wash Sink Indirect Waste - PVC Schedule 40 solid-wall ASTM D 2665, plastic pipe and socket type fittings, made to ASTM D 3311, drain, waste, and vent patterns. Joined using cement primer meeting requirements of ASTM F 656 and pipe cement meeting requirements of ASTM D 2564.

3.2 PIPING INSTALLATION

- A. Install waste and vent systems as indicated. Field verify location of existing piping systems in crawl space and above ceiling. Make all required connections to existing storm, waste and vent systems as indicated or as required.
- B. Install cast-iron soil piping according to CISPI's "Cast Iron Soil Pipe and Fittings Handbook," Chapter IV, "Installation of Cast Iron Soil Pipe and Fittings." Provide required transitions between cast iron and PVC or ABS piping.
- C. Make changes in direction for soil and waste drainage and vent piping using appropriate branches, bends, and long-sweep bends. Sanitary tees and short-sweep 1/4 bends may be used on vertical stacks if change in direction of flow is from horizontal to vertical. Use long-turn, double Y-branch and 1/8-bend fittings if 2 fixtures are installed back to back or side by side with common drain pipe. Straight tees, elbows, and crosses may be used on vent lines. Do not change direction of flow more than 90 degrees. Use proper size of standard increasers and reducers if pipes of different sizes are connected. Reducing size of drainage piping in direction of flow is prohibited.
- D. Install piping to drain. Install true to grades and alignment indicated, with unbroken continuity of invert. Verify inverts of existing piping systems prior to installation.
- E. Install storm, soil and waste drainage and vent piping at the following minimum slopes, unless otherwise indicated:
 - 1. Building Sanitary Drain: 2 percent downward in direction of flow.
- F. Do not enclose, cover, or put piping into operation until it is inspected and approved by authorities having jurisdiction.

3.3 JOINT CONSTRUCTION

- A. Cast-Iron, Soil-Piping Joints: Make joints according to CISPI's "Cast Iron Soil Pipe and Fittings Handbook," Chapter IV, "Installation of Cast Iron Soil Pipe and Fittings."
 - 1. Hubless Joints: Make with rubber gasket and sleeve or clamp.

3.4 HANGER AND SUPPORT INSTALLATION

- A. Support piping and tubing according to MSS SP-69 and manufacturer's written instructions.
- B. Pipe hangers and supports are specified in Division 22 Section "Hangers and Supports for Plumbing Piping and Equipment." Install the following:
 - 1. Vertical Piping: MSS Type 8 or Type 42, clamps.
 - 2. Individual, Straight, Horizontal Piping Runs: According to the following:
 - a. 100 Feet and Less: MSS Type 1, adjustable, steel clevis hangers.
 - 3. Base of Vertical Piping: MSS Type 52, spring hangers.
- C. Install supports according to Division 22 Section "Hangers and Supports for Plumbing Piping and Equipment."
- D. Support vertical piping and tubing at base and at each floor.

3.5 CONNECTIONS

- A. Connect soil and waste piping to exterior sanitary sewerage piping. Use transition fitting to join dissimilar piping materials.
- B. Connect storm drain piping to exterior storm drain piping. Use transition fitting to join dissimilar piping materials.
- C. Connect drainage and vent piping to the following:
 - 1. Plumbing Fixtures: Connect drainage piping in sizes indicated, but not smaller than required by plumbing code.

3.6 FIELD QUALITY CONTROL

- A. During installation, notify authorities having jurisdiction at least 24 hours before inspection must be made. Perform tests specified below in presence of authorities having jurisdiction.
 - 1. Roughing-in Inspection: Arrange for inspection of piping before concealing or closing-in after roughing-in and before setting fixtures.
 - 2. Final Inspection: Arrange for final inspection by authorities having jurisdiction to observe tests specified below and to ensure compliance with requirements.
- B. Re-inspection: If authorities having jurisdiction find that piping will not pass test or inspection, make required corrections and arrange for re-inspection.
- C. Reports: Prepare inspection reports and have them signed by authorities having jurisdiction.
- D. Test sanitary drainage and vent piping according to procedures of authorities having jurisdiction.

1. Repair leaks and defects with new materials and retest piping, or portion thereof, until satisfactory results are obtained.
2. Prepare reports for tests and required corrective action.

3.7 CLEANING

- A. Clean interior of piping. Remove dirt and debris as work progresses.
- B. Protect drains during remainder of construction period to avoid clogging with dirt and debris and to prevent damage from traffic and construction work.
- C. Place plugs in ends of uncompleted piping at end of day and when work stops.

END OF SECTION 22 1316

SECTION 22 1319 - SANITARY WASTE PIPING SPECIALTIES**PART 1 - GENERAL****1.1 SUMMARY**

- A. This Section includes the following sanitary drainage piping specialties:

Adjust list below to suit Project.

1. Cleanouts.
2. Floor drains.
3. Floor Sinks
4. Miscellaneous sanitary drainage piping specialties.
5. Flashing materials.

- B. Refer to Kitchen Equipment Contractor (KEC) drawings for additional waste and drain piping requirements.

1.2 SUBMITTALS

- A. Product Data: For each type of product indicated. Include rated capacities, operating characteristics, and accessories for grease interceptors.

1.3 QUALITY ASSURANCE

- A. Drainage piping specialties shall bear label, stamp, or other markings of specified testing agency.

PART 2 - PRODUCTS**2.1 CLEANOUTS**

- A. Exposed Cast-Iron Cleanouts
1. Manufacturers: Subject to compliance with requirements, provide products by one of the following:
 - a. Josam Company; Josam Div.
 - b. Smith, Jay R. Mfg. Co.; Division of Smith Industries, Inc.
 - c. Tyler Pipe; Wade Div.
 - d. Watts Drainage Products Inc.
 - e. Zurn Plumbing Products Group; Specification Drainage Operation.
 2. Standard: ASME A112.36.2M for cast iron for cleanout test tee.
 3. Size: Same as connected drainage piping
 4. Body Material: As required to match connected piping.
 5. Closure: Countersunk or raised-head plug.
 6. Closure Plug Size: Same as or not more than one size smaller than cleanout size.
- B. Cleanouts General

1. Manufacturers: Subject to compliance with requirements, provide products by one of the following:
 - a. Josam Company; Josam Div.
 - b. Smith, Jay R. Mfg. Co.; Division of Smith Industries, Inc.
 - c. Tyler Pipe; Wade Div.
 - d. Watts Drainage Products Inc.
 - e. Zurn Plumbing Products Group; Light Commercial Operation.

C. Floor Cleanouts

1. Standard: ASME A112.36.2M.
2. Size: Same as connected branch.
3. Type: Adjustable
4. Body or Ferrule: Cast iron
5. Frame and Cover Material and Finish: Nickel-bronze, copper alloy
6. Frame and Cover Shape: Round
7. Top Loading Classification: Light Duty.

D. Cast-Iron Wall Cleanouts

1. Standard: ASME A112.36.2M.
2. Size: Same as connected drainage piping.
3. Body: Hub-and-spigot or Hubless, cast-iron soil pipe test tee as required to match connected piping.
4. Closure: Countersunk plug.
5. Closure Plug Size: Same as or not more than one size smaller than cleanout size.
6. Wall Access: Round, flat, chrome-plated brass cover plate with screw.

2.2 FLOOR DRAINS

A. Cast-Iron Floor Drains

1. Manufacturers: Subject to compliance with requirements, provide products by one of the following:
 - a. Josam Company; Josam Div.
 - b. Smith, Jay R. Mfg. Co.; Division of Smith Industries, Inc.
 - c. Tyler Pipe; Wade Div.
 - d. Watts Drainage Products Inc.
 - e. Zurn Plumbing Products Group; Light Commercial Operation.
2. Standard: ASME A112.6.3
3. Body Material: Gray iron
4. Clamping Device: As Needed
5. Outlet: Bottom
6. Top or Strainer Material: Nickel bronze
7. Top of Body and Strainer Finish: Nickel bronze
8. Top Shape: Round or Square to match floor covering.
9. Trap Pattern: Deep-seal P-trap with Proset Trap Guard

2.3 FLOOR SINKS

A. Enameled Cast-Iron Floor Sinks

1. Manufacturers: Subject to compliance with requirements, provide products by one of the following:

- a. Josam Company; Josam Div.
 - b. Smith, Jay R. Mfg. Co.; Division of Smith Industries, Inc.
 - c. Tyler Pipe; Wade Div.
 - d. Watts Drainage Products Inc.
 - e. Zurn Plumbing Products Group; Light Commercial Operation.
2. Standard: ASME A112.6.3
 3. Body Material: Gray iron with white enamel interior
 4. Clamping Device: As Needed
 5. Outlet: Bottom
 6. Top or Strainer Material: Nickel bronze 1/2, 3/4 or full grate
 7. Top of Body and Strainer Finish: Nickel bronze
 8. Top Shape: Square to match floor covering.
 9. Trap Pattern: Deep-seal P-trap with Proset Trap Guard

2.4 MISCELLANEOUS SANITARY DRAINAGE PIPING SPECIALTIES

A. Deep-Seal Traps

1. Description: Cast-iron or bronze casting, with inlet and outlet matching connected piping and Proset Trap Guard
2. Size: Same as connected waste piping.

B. Stack Flashing Fittings

1. Description: Counterflashing-type, cast-iron fitting, with bottom recess for terminating roof membrane, and with threaded or hub top for extending vent pipe.
2. Size: Same as connected stack vent or vent stack.

2.5 FLASHING MATERIALS

A. Lead Sheet: ASTM B 749, Type L51121, copper bearing, with the following minimum weights and thicknesses, unless otherwise indicated:

1. General Use: 4.0-lb/sq. ft. thickness.
2. Vent Pipe Flashing: 3.0-lb/sq. ft. thickness.

B. Fasteners: Metal compatible with material and substrate being fastened.

C. Metal Accessories: Sheet metal strips, clamps, anchoring devices, and similar accessory units required for installation; matching or compatible with material being installed.

D. Solder: ASTM B 32, lead-free alloy.

E. Bituminous Coating: SSPC-Paint 12, solvent-type, bituminous mastic.

PART 3 - EXECUTION

3.1 INSTALLATION

- A. Refer to Division 22 Section "Common Work Results for Plumbing" for piping joining materials, joint construction, and basic installation requirements.

- B. Install cleanouts in aboveground piping and building drain piping according to the following, unless otherwise indicated:
 - 1. Size same as drainage piping up to NPS 4
 - 2. Locate at each change in direction of piping greater than 45 degrees.
 - 3. Locate at minimum intervals of 50 feet for piping NPS 4 and smaller.
 - 4. Locate at base of each vertical soil and waste stack.
- C. For floor cleanouts for piping below floors, install cleanout deck plates with top flush with finished floor.
- D. For cleanouts located in concealed piping, install cleanout wall access covers, of types indicated, with frame and cover flush with finished wall.
- E. Install floor drains at low points of surface areas to be drained. Set grates of drains flush with finished floor, unless otherwise indicated.
 - 1. Position floor drains for easy access and maintenance.
 - 2. Set floor drains at elevation of surrounding finished floor.
 - 3. Install floor-drain flashing collar or flange so no leakage occurs between drain and adjoining flooring. Maintain integrity of waterproof membranes where penetrated.
 - 4. Install individual traps for floor drains connected to sanitary building drain, unless otherwise indicated.
- F. Install floor sinks where indicated for indirect waste receiving. Set grates of type required for indirect waste flush with finished floor, unless otherwise indicated.
- G. Install roof flashing assemblies on sanitary stack vents and vent stacks that extend through roof. Install flashing fittings on sanitary stack vents and vent stacks that extend through roof.
- H. Install deep-seal traps with Proset trap guards or trap seals on floor drains, floor sinks and other waste outlets.
- I. Install traps on plumbing specialty drain outlets. Omit traps on indirect wastes unless trap is indicated.
- J. Install escutcheons at wall, floor, and ceiling penetrations in exposed finished locations and within cabinets and millwork. Use deep-pattern escutcheons if required to conceal protruding pipe fittings.

3.2 CONNECTIONS

- A. Piping installation requirements are specified in other Division 22 Sections. Drawings indicate general arrangement of piping, fittings, and specialties.
- B. Pipe indirect waste lines from dishwashers, prep sinks, wash sinks and other plumbing fixtures as required. Coordinate installation of kitchen equipment plumbing fixtures with required indirect wastes.
- C. Install piping adjacent to equipment to allow service and maintenance.

3.3 FLASHING INSTALLATION

- A. Fabricate flashing from single piece unless large pans, sumps, or other drainage shapes are required.
- B. Install sheet flashing on pipes, sleeves, and specialties passing through roofs with waterproof membrane.
- C. Set flashing on roofs in solid coating of bituminous cement.
- D. Secure flashing into sleeve and specialty clamping ring or device.
- E. Install flashing for piping passing through roofs with counterflashing or commercially made flashing fittings.

3.4 PROTECTION

- A. Protect drains during remainder of construction period to avoid clogging with dirt or debris and to prevent damage from traffic or construction work.
- B. Place plugs in ends of uncompleted piping at end of each day or when work stops.

END OF SECTION 22 1319

SECTION 22 4000 – PLUMBING FIXTURES**PART 1 - GENERAL****SUMMARY**

- A. This Section includes the following:
 - 1. Plumbing Fixtures
 - 2. Plumbing Equipment
 - 3. Floor drains.
 - 4. Roof flashing assemblies.
 - 5. Miscellaneous sanitary drainage piping specialties.
 - 6. Flashing materials.

- B. Refer to Kitchen Equipment Contractor (KEC) drawings and kitchen equipment submittals for additional plumbing or kitchen equipment fixtures and required plumbing connections. This contractor is responsible for installing all kitchen equipment and plumbing fixtures furnished by the KEC and as noted on the KEC drawings. Make all required drainage, waste, vent, water, gas and indirect piping connections for a complete and functional installation.

SUBMITTALS

- C. Product Data: For each type of product or equipment indicated. Include rated capacities, operating characteristics, and accessories.

- D. Shop Drawings: Diagram power, signal, and control wiring.

- E. Operation and maintenance data.

1.2 QUALITY ASSURANCE

- A. Electrical Components, Devices, and Accessories: Listed and labeled as defined in NFPA 70, Article 100, by a testing agency acceptable to authorities having jurisdiction, and marked for intended use.

- B. Regulatory Requirements: Comply with requirements in ICC A117.1, "Accessible and Usable Buildings and Facilities, "Americans with Disabilities Act"; for plumbing fixtures for people with disabilities.

- C. Select combinations of fixtures and trim, faucets, fittings, and other components that are compatible.

PART 2 - PRODUCTS

- A. Manufacturers: Subject to compliance with requirements, provide fixtures, products, valves and or accessories by one of the following:
 - a. American Standard Companies, Inc.

- b. Bradley Corporation.
- c. Crane Plumbing, L.L.C./Fiat Products.
- d. Chicago Faucets.
- e. Coyne & Delany Co.
- f. Delta Faucet Company.
- g. Elkay Manufacturing Co.
- h. Just Manufacturing Company.
- i. Kohler Co.
- j. Moen, Inc.
- k. Royal Brass Mfg. Co.
- l. Sayco; a Briggs Plumbing Products, Inc. Company.
- m. Speakman Company.
- n. T & S Brass and Bronze Works, Inc.
- o. Zurn Plumbing Products Group; Commercial Brass Operation.
- p. Central Brass Manufacturing Company.
- q. Symmons Industries, Inc.
- r. Sloan Valve Company.
- s. TOTO USA, Inc.
- t. Bemis Manufacturing Company.
- u. Church Seats.
- v. Kohler Co.
- w. Olsonite Corp.
- x. Josam Company.
- y. Smith, Jay R. Mfg. Co.
- z. Tyler Pipe; Wade Div.
- aa. Watts Drainage Products Inc.; a div. of Watts Industries, Inc.

B. Plumbing Equipment

- a. Rheem Inc Water Heaters and Tanks
- b. Bradford-White Water Heaters and Tanks
- c. A.O. Smith Water Heaters and Tanks
- d. PVI Water Heaters
- e. Bell & Gossett, Xylem Pumps, Expansion Tanks
- f. Grundfos Pumps
- g. Taco Pumps and Expansion Tanks
- h. Amtrol Expansion Tanks
- i. Schier, Grease Interceptors

C. Water Closet Supports

1. Description: Heavy duty with fixture support plates and coupling with seal and fixture bolts and hardware matching fixture for wall-mounting, water closet fixtures. Include steel uprights with feet.

- D. The contractor shall furnish and install all plumbing fixtures shown on the plumbing drawings or specified hereinafter, clean and adjust all fixtures and replace any damaged fixtures at the contractor's expense. The fixtures shall be new and complete as shown and described in manufacturer's catalog, and as required for the work, including accessible loose key 1/4 turn ball valve stops above the floor in supplies to all fixtures, and cast brass P-traps, unless otherwise shown. Trim for all fixtures shall be chrome-plated, and all trim shall match in design. Supply faucets shall have renewable seats and barrels.

PLUMBING FIXTURES

WC/1	Water Closet (ADA):	Kohler K-4330 'Kingston' syphon jet, wall hung, elongated bowl, 1-1/2" top spud; Zurn Z6000AV 1.6 gpf chrome plated manual flush valve; K-666C 'Bemis 1955C extra heavy solid plastic white open front seat with stainless steel check hinge; Wade W-311 (horizontal) or W-331 (vertical) series carrier, as required, with foot support.
L/1	Lavatory (ADA):	Kohler K-2032 "Greenwich" 20" x 18" - 4" center set vitreous china, front overflow, anti-splash rim, center basin, wall hanger, punched for concealed arm carrier, Moen L64601 #505 faucet with grid strainer (no substitutions), Watts USG-B ASSE 1070 thermostatic mixing valve. Tailpiece and flexible supplies w/stops and brass P-trap. Support lavatory with Zurn ZN1231 concealed arm carrier with foot support. Provide ADA Insulation Kit by Plumberex or Truebro.
SS/1	Service Sink:	Kohler K-6710 "Whitby" 28" x 28" cast iron enameled service sink, floor mounted, drain channels; Kohler 8928-CP polished chrome faucet with vacuum breaker, hose end with hose, bucket hook, wall brace integral stops and rough chrome finish. Faucet to be mounted 36" above finished floor; K-8940 rim guard; K-9146 drain with strainer for 3" connection. Furnish with 30 inch hose and wall mounted hose retainer clamp
MV/1	Mixing Valve:	Watts USG-B ASSE 1070 thermostatic mixing valve. Under lavatory mount with 3/8" male compression inlets and 3/8" tempered outlet, integral check valves, tamper resistant locking nut and integral strainer. Set at 110 deg F outlet temperature.
HB/1	Hose Bibb:	Zurn Z-1350 Encased Ecolotrol "anti-siphon" wall hydrant, for exterior, non-freeze, flush wall installation. Complete with integral backflow preventer, all bronze casing and interior parts, non-turning operating coupling with hemispherical neoprene plunger and 3/4" solder inlet. Nickel bronze box and hinged cover with operating key lock and "WATER" stamped or cast on cover. Sawcut existing foundation wall as needed for installation.
FD-1	Floor Drain:	Zurn #Z-415-4 cast iron floor drain with nickel bronze top. Size as noted on the drawings. Drain to have deep seal P-trap with Proset trap guard.
FS-1	Floor Sink:	Zurn ZN-1900 Sanitor floor sink. Size as noted on the drawings. With 12" x 12" square top, full removable grate with center opening. N.B. dome, sani-coated exterior, acid resistant enamel interior, and Z-100 deep seal trap. Sink shall be complete with full grate, 3/4 grate, 1/2 grate, etc. as necessary to match application. Sink to be installed flush with floor.
A/1	Arrestor:	JR Smith 5060. Stainless steel bellows type, 1 inch connection size. Furnish with ball isolation valve.

PLUMBING EQUIPMENT

- WH-1 Water Heater: Bradford White EF-100T-150E-3N. Natural gas fired, 96% efficient with AGA approved gas train, 100 gallon storage capacity, electronic controls, glass lined insulated tank, full port brass drain valve, dielectric fittings, magnesium anodes. 199 MBH input with 239 GPH recovery thru 100 deg F temperature rise. 3" dia. Schedule 40 solid wall PVC vent and combustion air intakes. Furnish complete with P&T relief valve, 4 inch high concrete pad and seismic restraint cables or straps. Provide 120 volt dedicated power circuit and localized toggle switch disconnect for water heater controls.
- CP-1 Water Heater: Bell & Gossett Model PL-55 domestic water, all bronze construction circulation pump. Permanently lubricated bearings, in-line type configuration for 140 deg F water. 10 GPM at 20 Feet head capacity rating. 1/5 HP pump motor, 3250 RPM, 3/4" inlet and outlet connections. Provide 120 volt dedicated power circuit and localized toggle switch disconnect. Provide inlet and outlet unions and ball valves for service duty and disconnect.
- EX-1 Expansion Tank: Amtrol ST-12 domestic water expansion tank. Non-ASME type, 5.0 gallon total volume, 0.45 acceptance factor, 1/2" NPT inlet connection. Maximum working pressure = 150 PSI, Maximum working temperature = 200 deg F. NSF 61 listed for domestic water service. 12" dia x 18" high. Provide wall mounting kit for securing to wall.
- GI-1 Grease Interceptor: Schier GB-75 heavy duty grease interceptor. Heavy duty polyethylene construction, 75 GPM flowrate, 616 LBS grease capacity, 125 gallon liquid capacity. 4 inch PVC inlet and outlet, heavy duty 24" dia. bolted composite cover. 46" long x 32" wide and 38-1/2" tall. Install on 4 inch high concrete pad with seismic anchor straps. Provide flow control valve on inlet of Grease Interceptor.

PART 3 - EXECUTION

INSTALLATION

- A. Assemble plumbing fixtures, equipment, trim, fittings, and other components according to manufacturers' written instructions.
- B. Coordinate with the Kitchen Equipment Contractor (KEC) regarding the installation and piping of all fixtures and equipment provided by them. This contractor is responsible for installing all kitchen equipment and plumbing fixtures furnished by the KEC and as noted on the KEC drawings. Make all required drainage, waste, vent, water, gas and indirect piping connections for a complete and functional installation.
- C. Install off-floor supports, affixed to building substrate, for wall-mounting fixtures.
 1. Use carrier supports with waste fitting and seal for back-outlet fixtures.
 2. Use carrier supports without waste fitting for fixtures with tubular waste piping.

- D. Install back-outlet, wall-mounting fixtures onto waste fitting seals and attach to supports.
- E. Install floor-mounting fixtures on closet flanges or other attachments to piping or building substrate.
- F. Install wall-mounting fixtures with tubular waste piping attached to supports.
- G. Install fixtures level and plumb according to manufacturer's roughing-in drawings.
- H. Install water-supply piping with stop on each supply to each fixture to be connected to water distribution piping. Attach supplies to supports or substrate within pipe spaces behind fixtures. Install stops in locations where they can be easily reached for operation.
- I. Install trap and tubular waste piping on drain outlet of each fixture to be directly connected to sanitary drainage system.
- J. Install tubular waste piping on drain outlet of each fixture to be indirectly connected to drainage system.
- K. Install flushometer valves for accessible water closets with handle mounted on wide side of compartment. Install other actuators in locations that are easy for people with disabilities to reach.
- L. Install toilet seats with sustaining check hinge on water closets.
- M. Install faucet-spout fittings with specified flow rates and patterns in faucet spouts if faucets are not available with required rates and patterns. Include adapters if required.
- N. Install water-supply flow-control fittings with specified flow rates in fixture supplies at stop valves.
- O. Install faucet flow-control fittings with specified flow rates and patterns in faucet spouts if faucets are not available with required rates and patterns. Include adapters if required.
- P. Install grease interceptor flow-control fittings.
- Q. Install traps on fixture outlets.
 - 1. Exception: Omit trap on fixtures with integral traps.
 - 2. Exception: Omit trap on indirect wastes, unless otherwise indicated.
- R. Install escutcheons at piping wall and ceiling penetrations in exposed, finished locations and within cabinets and millwork. Use deep-pattern escutcheons if required to conceal protruding fittings.
- S. Seal joints between fixtures and walls, floors, and countertops using sanitary-type, one-part, mildew-resistant silicone sealant. Match sealant color to fixture color. Sealants are specified in Division 07 Section "Joint Sealants."
- T. Piping installation requirements are specified in other Division 22 Sections. Drawings indicate general arrangement of piping, fittings, and specialties. Make all required water, waste, vent and drain connections for a complete and functional plumbing system.

- U. Connect fixtures with water supplies, stops, and risers, and with traps, soil, waste, and vent piping. Use size fittings required to match fixtures.
- V. Verify that installed plumbing fixtures are categories and types specified for locations where installed. Check that plumbing fixtures are complete with trim, faucets, fittings, and other specified components. Inspect installed plumbing fixtures for damage. Replace damaged fixtures and components.
- W. Test installed fixtures after water systems are pressurized for proper operation. Replace malfunctioning fixtures and components, then retest. Repeat procedure until units operate properly.
- X. Provide protective covering for installed fixtures and fittings. Do not allow use of plumbing fixtures for temporary facilities unless approved in writing by Owner.

END OF SECTION 22 4000

SECTION 23 0500 - COMMON WORK RESULTS FOR HVAC**PART 1 - GENERAL****1.1 SUMMARY**

- A. This Section includes the following:
 - 1. HVAC demolition.
 - 2. Equipment installation requirements common to equipment sections.
 - 3. Supports and anchorages.

1.2 QUALITY ASSURANCE

- A. Steel Support Welding: Qualify processes and operators according to AWS D1.1, "Structural Welding Code--Steel."

PART 2 - PRODUCTS (Not Used)**PART 3 - EXECUTION****3.1 HVAC DEMOLITION**

- A. Disconnect, demolish, and remove HVAC systems, equipment, and components indicated to be removed.
 - 1. Ducts to Be Removed: Remove complete ducts indicated to be removed. Remove all associated ductwork supports that are not re-used as part of the new work.
 - 2. Equipment to Be Removed: Disconnect and cap services and remove equipment. Remove mechanical equipment complete. Remove all roof curb and equipment supports.
- B. Disconnect and remove existing cabinet unit heaters and fan coils as indicated. Remove heating hot water piping back to mains in crawl space and cap.
- C. Disconnect and remove roof mounted exhaust fans indicated to be removed complete. Remove all associated roof curbs and ductwork.
- D. Remove refrigeration equipment indicated to be removed complete. Reclaim all refrigerant. Do not vent to atmosphere. Remove all associated refrigeration piping, piping and equipment supports.
- E. If pipe, insulation, or equipment to remain is damaged in appearance or is unserviceable, remove damaged or unserviceable portions and replace with new products of equal capacity and quality.

3.2 EQUIPMENT INSTALLATION - COMMON REQUIREMENTS

- A. Install equipment to allow maximum possible headroom unless specific mounting heights are not indicated.
- B. Install roof top equipment on 14 inch high minimum factory insulated and fabricated roof curbs. Provide minimum of 12 inches separation between finished roof line and bottom of mechanical equipment.
- C. Install 4 inch high concrete sweep curb for equipment indicated.

- D. Install roof mounted utility set exhaust fans on 14 inch high roof curb or base. Infill roof curb with water-proof polyiso insulation board to provide sound attenuation and thermal integrity
- E. Install Outside Air Penthouses 14 inch high minimum factory insulated and fabricated roof curbs. Provide minimum of 12 inches separation between finished roof line and bottom of mechanical equipment.
- F. Install mechanical equipment level and plumb, parallel and perpendicular to other building systems and components in exposed interior spaces, unless otherwise indicated.
- G. All materials and equipment shall be installed in strict compliance with the manufacturer's recommendations. Furnish and set, in all necessary locations, before or during construction, unistrut inserts for use in connection with the support and seismic restraint of piping, ductwork, and equipment furnished under this division of the work.
- H. Provide galvanized iron sleeves with collar on each side of wall for all ducts passing thru masonry or concrete construction.
- I. Steel roof deck shall not be used to support loads from HVAC ducts or equipment of any kind, unless specifically noted otherwise. Provide supports staggered to distribute the load over multiple deck flutes.
- J. All materials and equipment shall be installed in strict compliance with the manufacturer's recommendations.
- K. Under no circumstances shall plastic piping or ducting materials be run inside of supply or return air plenums. Where PVC flues or combustion air piping are installed in return air plenums, piping shall be wrapped with 1-1/2" thick fire wrap insulation.
- L. Roof curbs shall provide a free height from the roof membrane to the top of the curb of at least 12" minimum. All roof curbs and platforms shall have a wood nailer strip around the top perimeter for securing the roof membrane and attaching roof flashings. Roof curbs shall be infilled with polyiso insulation board of thickness to match roof thermal barrier.
- M. Roof curbs shall be attached to building structure as required by the IMC and local codes.
- N. All mechanical equipment furnished under this division shall have single point power connections. All roof top mounted exhaust fans and roof top heating and cooling units shall be furnished with factory mounted disconnects for single point power connections.
- O. Magnetic starters shall provide both overload and undervoltage protection and shall have integral hand-off-auto switch, auxiliary contacts, and pilot. All motors installed under this contract shall have a disconnect switch in the immediate vicinity of the motor. Starters on three phase motors shall protect all three legs of the circuit. Starters to be Cutler-Hammer, Square "D", or Westinghouse.
- P. All Division 23 equipment, piping, and ductwork shall be anchored and seismically restrained as required by the IBC for Seismic Zone C, NFPA 90A (current edition), UL Standard 181, Tri-services Manual Fagel Et Al 1973, and the SMACNA Guidelines for seismic restraints of mechanical systems.
- Q. The Division 23 contractor shall be responsible for supplying and installing equipment, vibration isolators, flexible connections, rigid steel frames, anchors, inserts, hangers and attachments, supports, seismic snubbers and bracing to comply with Seismic Zone C of the International Building Code.

- R. All supports, hangers, bases, anchorage and bracing for all isolated equipment shall be designed by a professional engineer employed by the restraint manufacturer, qualified with seismic experience in bracing for mechanical equipment.
- S. All equipment which is to be furnished in factory prefinished conditions by the mechanical contractor shall be left without mark, scratch, or impairment to finish upon completion of job. Any necessary refinishing to match original shall be done. Do not paint over nameplates, serial numbers, or other identifying marks.
- T. All valves and equipment shall be located to allow easy access for inspection, service and maintenance, test and balance, and operation. If valves are installed in inaccessible locations it shall be this contractor's responsibility to furnish and install access doors of a type approved by the owner's representative.
- U. Install HVAC equipment to facilitate service, maintenance, and repair or replacement of components. Connect equipment for ease of disconnecting, with minimum interference to other installations. Extend grease fittings to accessible locations.
- V. Install equipment to allow right of way for piping installed at required slope.

3.3 ERECTION OF METAL SUPPORTS AND ANCHORAGES

- A. Refer to Division 05 Section "Metal Fabrications" for structural steel.
- B. Cut, fit, and place miscellaneous metal supports accurately in location, alignment, and elevation to support and anchor HVAC materials and equipment.
- C. Field Welding: Comply with AWS D1.1.

END OF SECTION 23 0500

SECTION 23 0548 - VIBRATION AND SEISMIC CONTROLS FOR HVAC PIPING AND EQUIPMENT**PART 1 - GENERAL****1.1 SUMMARY**

- A. This Section includes the following:
 - 1. Restraining braces and cables.

1.2 PERFORMANCE REQUIREMENTS

- A. Seismic-Restraint Loading:
 - 1. Site Class as Defined in the IBC: C

1.3 SUBMITTALS

- A. Product Data: For each product indicated.

1.4 QUALITY ASSURANCE

- A. Comply with seismic-restraint requirements in the IBC unless requirements in this Section are more stringent.
- B. Seismic-restraint devices shall have horizontal and vertical load testing and analysis and shall bear anchorage preapproval OPA number from OSHPD, preapproval by ICC-ES, or preapproval by another agency acceptable to authorities having jurisdiction, showing maximum seismic-restraint ratings. Ratings based on independent testing are preferred to ratings based on calculations. If preapproved ratings are not available, submittals based on independent testing are preferred. Calculations (including combining shear and tensile loads) to support seismic-restraint designs must be signed and sealed by a qualified professional engineer.

PART 2 - PRODUCTS**2.1 SEISMIC-RESTRAINT DEVICES**

- A. Manufacturers: Subject to compliance with requirements, provide products by one of the following:
 - 1. Amber/Booth Company, Inc.
 - 2. Mason Industries.
 - 3. Unistrut; Tyco International, Ltd.
 - 4. Seismic Restraint Systems
- B. Restraint Cables: ASTM A 492 stainless-steel cables with end connections made of steel assemblies with thimbles, brackets, swivel, and bolts designed for restraining cable service; and with a minimum of two clamping bolts for cable engagement.

PART 3 - EXECUTION

3.1 APPLICATIONS

- A. Strength of Support and Seismic-Restraint Assemblies: Where not indicated, select sizes of components so strength will be adequate to carry present and future static and seismic loads within specified loading limits.

3.2 VIBRATION-CONTROL AND SEISMIC-RESTRAINT DEVICE INSTALLATION

- A. Piping Restraints:
 - 1. Comply with requirements in MSS SP-127.
- B. Install cables so they do not bend across edges of adjacent equipment or building structure.
- C. Install seismic-restraint devices using methods approved by an evaluation service member of an agency acceptable to authorities having jurisdiction providing required submittals for component.
- D. Install bushing assemblies for anchor bolts for floor-mounted equipment, arranged to provide resilient media between anchor bolt and mounting hole in concrete base.
- E. Attachment to Structure: If specific attachment is not indicated, anchor bracing to structure at flanges of beams, at upper truss chords of bar joists, or at concrete members.
- F. Drilled-in Anchors:
 - 1. Identify position of reinforcing steel and other embedded items prior to drilling holes for anchors. Do not damage existing reinforcing or embedded items during coring or drilling. Notify the structural engineer if reinforcing steel or other embedded items are encountered during drilling. Locate and avoid prestressed tendons, electrical and telecommunications conduit, and gas lines.
 - 2. Do not drill holes in concrete or masonry until concrete, mortar, or grout has achieved full design strength.
 - 3. Wedge Anchors: Protect threads from damage during anchor installation. Heavy-duty sleeve anchors shall be installed with sleeve fully engaged in the structural element to which anchor is to be fastened.
 - 4. Set anchors to manufacturer's recommended torque, using a torque wrench.
 - 5. Install zinc-coated steel anchors for interior and stainless-steel anchors for exterior applications.

3.3 ACCOMMODATION OF DIFFERENTIAL SEISMIC MOTION

- A. Install flexible connections in piping where they cross seismic joints, where adjacent sections or branches are supported by different structural elements, and where the connections terminate with connection to equipment that is anchored to a different structural element from the one supporting the connections as they approach equipment.

3.4 FIELD QUALITY CONTROL

- A. Perform tests and inspections.
- B. Tests and Inspections:
 - 1. Provide evidence of recent calibration of test equipment by a testing agency acceptable to authorities having jurisdiction.
 - 2. Schedule test with Owner, through Architect, before connecting anchorage device to restrained component unless post.connection testing has been approved, and with at least seven days' advance notice.
 - 3. Obtain Architect's approval before transmitting test loads to structure. Provide temporary load-spreading members.
- C. Remove and replace malfunctioning units and retest as specified above.
- D. Prepare test and inspection reports.

3.5 ADJUSTING

- A. Adjust isolators after piping system is at operating weight.
- B. Adjust limit stops on restrained spring isolators to mount equipment at normal operating height. After equipment installation is complete, adjust limit stops so they are out of contact during normal operation.
- C. Adjust active height of spring isolators.
- D. Adjust restraints to permit free movement of equipment within normal mode of operation.

END OF SECTION 23 0548

SECTION 23 0553 - IDENTIFICATION FOR HVAC PIPING AND EQUIPMENT**PART 1 - GENERAL****1.1 SUMMARY**

- A. Section Includes:
 - 1. Equipment labels.
 - 2. Pipe labels.
 - 3. Duct labels.

1.2 SUBMITTAL

- A. Product Data: For each type of product indicated.

PART 2 - PRODUCTS**2.1 EQUIPMENT LABELS**

- A. Plastic Labels for Equipment:
 - 1. Material and Thickness: Multilayer, multicolor, plastic labels for mechanical engraving, 1/16 inch thick, and having predrilled holes for attachment hardware.
 - 2. Letter Color: White
 - 3. Background Color: Black
 - 4. Minimum Label Size: Length and width vary for required label content, but not less than 2-1/2 by 3/4 inch
 - 5. Minimum Letter Size: 1/4 inch for name of unit
 - 6. Fasteners: Stainless-steel rivets or self-tapping screws
- B. Label Content: Include equipment's Drawing designation or unique equipment number, Drawing numbers where equipment is indicated (plans, details, and schedules), plus the Specification Section number and title where equipment is specified.

2.2 PIPE LABELS

- A. General Requirements for Manufactured Pipe Labels: Preprinted, color-coded, with lettering indicating service, and showing flow direction.
- B. Self-Adhesive Pipe Labels: Printed plastic with contact-type, permanent-adhesive backing.
- C. Pipe Label Contents: Include identification of piping service using same designations or abbreviations as used on Drawings, pipe size, and an arrow indicating flow direction.
 - 1. Flow-Direction Arrows: Integral with piping system service lettering to accommodate both directions, or as separate unit on each pipe label to indicate flow direction.
 - 2. Lettering Size: At least 1-1/2 inches high.

PART 3 - EXECUTION**3.1 PREPARATION**

- A. Clean piping and equipment surfaces of substances that could impair bond of identification devices, including dirt, oil, grease, release agents, and incompatible primers, paints, and encapsulants.

3.2 EQUIPMENT LABEL INSTALLATION

- A. Install or permanently fasten labels on each major item of mechanical equipment.
- B. Locate equipment labels where accessible and visible.

3.3 PIPE LABEL INSTALLATION

- A. Locate pipe labels where piping is exposed or above accessible ceilings in finished spaces; machine rooms; accessible maintenance spaces such as shafts, tunnels, and plenums; and exterior exposed locations as follows:
 - 1. Near each valve and control device.
 - 2. Near each branch connection, excluding short takeoffs for fixtures and terminal units. Where flow pattern is not obvious, mark each pipe at branch.
 - 3. Near penetrations through walls, floors, ceilings, and inaccessible enclosures.
 - 4. At access doors, manholes, and similar access points that permit view of concealed piping.
 - 5. Near major equipment items and other points of origination and termination.
 - 6. Spaced at maximum intervals of 50 feet along each run. Reduce intervals to 25 feet in areas of congested piping and equipment.
 - 7. On piping above removable acoustical ceilings. Omit intermediately spaced labels.
- B. Pipe Label Color Schedule:
 - 1. Natural Gas Piping:
 - a. Background Color: Yellow
 - b. Letter Color: Black
 - 2. Heating Hot Water Piping Supply:
 - a. Background Color: Yellow
 - b. Letter Color: Black
 - 3. Heating Hot Water Piping Return:
 - a. Background Color: Yellow
 - b. Letter Color: Black
 - 4. Refrigeration Piping
 - a. Background Color: Yellow
 - b. Letter Color: Black

END OF SECTION 23 0553

SECTION 23 0593 - TESTING, ADJUSTING, AND BALANCING FOR HVAC**PART 1 - GENERAL****1.1 SUMMARY**

- A. This Section includes TAB to produce design objectives for the following:
 - 1. Air Systems:
 - a. Make Up Air Systems
 - b. Exhaust Fan Systems
 - 2. Refrigeration Heat Pump Piping Systems:
 - a. Variable-flow systems..
 - 3. Reporting results of activities and procedures specified in this Section.

1.2 SUBMITTALS

- A. Certified TAB Reports: Submit two copies of reports prepared, as specified in this Section, on approved forms certified by TAB firm.
- B. Warranties specified in this Section.

1.3 QUALITY ASSURANCE

- A. TAB Firm Qualifications: Engage a TAB firm certified by AABC and/or NEBB.
- B. Certification of TAB Reports: Certify TAB field data reports. This certification includes the following:
 - 1. Review field data reports to validate accuracy of data and to prepare certified TAB reports.
 - 2. Certify that TAB team complied with approved TAB plan and the procedures specified and referenced in this Specification.

1.4 COORDINATION

- A. Coordinate the efforts of factory-authorized service representatives for systems and equipment, HVAC controls installers, and other mechanics to operate HVAC systems and equipment to support and assist TAB activities.
- B. Heat pump refrigeration piping to be balanced to correct capacities by the manufacturer's trained and authorized installer.

PART 2 - PRODUCTS (Not Applicable)**PART 3 - EXECUTION****3.1 EXAMINATION**

- A. The mechanical contractor shall provide and coordinate services of qualified, responsible subcontractors, suppliers, and personnel as required to correct, repair, or replace any and all deficient items or conditions found during the testing, adjusting, and balancing period.

- B. Before any adjustments are made, the air systems are to be checked for such items as dirty filters, duct leakage, damper leakage, equipment vibrations, correct damper operations, correct fan rotation etc.
 - C. It shall be the responsibility of the CAB personnel to check, adjust, and balance the components of the various systems as listed above using an applicable "proportionate balance procedure" in order that each of them will operate under optimum noise, temperature and air flow conditions in the conditioned spaces in the building "while simultaneously operating at the most energy efficient condition."
 - D. During the balancing process, if abnormalities or malfunctions of equipment or components are discovered by the CAB personnel, the owner's representative shall be advised promptly so that the condition may be corrected by the project contractor. Data from malfunctioning equipment or components shall not be recorded in the final CAB report.
 - E. Temperature Tabulation: Of all conditioned spaces on a room-by-room basis, a total of at least three readings will be taken of each room on successive days. Record outside ambient temperature at two-hour intervals. The total variation in conditioned space temperatures shall not exceed 2 deg. variance from the thermostat settings.
 - F. Air Volumes and Velocities: As measured at each supply grille, return air grille, and exhaust air grille or air handling device. In all fan systems, the air quantities indicated on the plans may be varied as required to secure a maximum temperature variation of two degrees within each separately controlled space, but the total air quantity indicated for each zone must be obtained. It shall be the obligation of the contractor to furnish or revise fan drives, belts, drive sheaves, pulleys and/or motors, if necessary, without cost to the Owner, to attain the specified air volumes.
 - G. Examine HVAC system and equipment installations to verify that manual volume dampers, are properly installed, and that their locations are accessible and appropriate for effective balancing and for efficient system and equipment operation.
 - H. Examine equipment for installation and for properly operating safety interlocks and controls.
 - I. Report deficiencies discovered before and during performance of TAB procedures. Observe and record system reactions to changes in conditions. Record default set points if different from indicated values.
- 3.2 GENERAL PROCEDURES FOR TESTING AND BALANCING
- A. Perform testing and balancing procedures on each system according to the procedures contained in AABC's "National Standards for Testing and Balancing Heating, Ventilating, and Air Conditioning Systems"
 - 1. Comply with requirements in ASHRAE 62.1-2004, Section 7.2.2 - "Air Balancing."
- 3.3 GENERAL PROCEDURES FOR BALANCING AIR SYSTEMS
- A. Prepare test reports for both fans and outlets. Obtain manufacturer's outlet factors and recommended testing procedures. Crosscheck the summation of required outlet volumes with required fan volumes.
 - B. Check dampers for proper position to achieve desired airflow path.
- 3.4 PROCEDURES FOR CONSTANT VOLUME AIR SYSTEMS
- A. Adjust fans to deliver total indicated airflows within the maximum allowable fan speed listed by fan manufacturer.

1. Measure fan static pressures to determine actual static pressure as follows:
 - a. Measure outlet static pressure as far downstream from the fan as practicable and upstream from restrictions in ducts such as elbows and transitions.
 - b. Measure static pressure directly at the fan outlet or through the flexible connection.
 - c. Measure inlet static pressure of single-inlet fans in the inlet duct as near the fan as possible, upstream from flexible connection and downstream from duct restrictions.
 - d. Measure inlet static pressure of double-inlet fans through the wall of the plenum that houses the fan.
 - B. Adjust volume dampers for main duct, sub-main ducts, and major branch ducts to indicated airflows within specified tolerances.
 - C. Adjust terminal outlets and inlets for each space to indicated airflows within specified tolerances of indicated values. Make adjustments using volume dampers rather than extractors and the dampers at air terminals.
- 3.5 TEMPERATURE-CONTROL VERIFICATION
- A. Verify that controllers are calibrated and commissioned.
- 3.6 TOLERANCES
- A. Set HVAC system airflow and water flow rates within the following tolerances:
 1. Supply, Return, and Exhaust Fans and Equipment with Fans: Plus 5 to plus 10 percent.
 2. Air Outlets and Inlets: 0 to minus 10 percent.
- 3.7 FINAL REPORT
- A. General: Typewritten, or computer printout in letter-quality font, on standard bond paper, in three-ring binder, tabulated and divided into sections by tested and balanced systems.
 - B. General Report Data: In addition to form titles and entries, include the following data in the final report, as applicable:
 1. Title page.
 2. Name and address of TAB firm.
 3. Project name.
 4. Project location.
 5. Architect's name and address.
 6. Engineer's name and address.
 7. Contractor's name and address.
 8. Report date.
 9. Signature of TAB firm who certifies the report.
 10. Table of Contents with the total number of pages defined for each section of the report. Number each page in the report.
 11. Summary of contents including the following:
 - a. Indicated versus final performance.
 - b. Notable characteristics of systems.
 - c. Description of system operation sequence if it varies from the Contract Documents.
 12. Nomenclature sheets for each item of equipment.
 13. Data for terminal units, including manufacturer, type size, and fittings.
 14. Notes to explain why certain final data in the body of reports varies from indicated values.
 15. Test conditions for fans and pump performance forms including the following:
 - a. Settings for outside-, return-, and exhaust-air dampers.
 - b. Conditions of filters.
 - c. Cooling coil, wet- and dry-bulb conditions.
 - d. Face and bypass damper settings at coils.

- e. Fan drive settings including settings and percentage of maximum pitch diameter.
 - f. Settings for variable-air-volume systems.
 - g. Settings for supply-air, static-pressure controller.
 - h. Other system operating conditions that affect performance.
- C. System Diagrams: Include schematic layouts of air distribution systems. Present each system with single-line diagram and include the following:
- 1. Quantities of outside, supply, return, and exhaust airflows.
 - 2. Duct, outlet, and inlet sizes.
 - 3. Pipe and valve sizes and locations.
 - 4. Terminal units.
 - 5. Balancing stations.
 - 6. Position of balancing devices.

END OF SECTION 23 0593

SECTION 23 0700 - HVAC INSULATION**PART 1 - GENERAL****1.1 SUMMARY**

- A. Section Includes:
1. Insulation Materials:
 - a. Cellular glass.
 - b. Flexible elastomeric.
 - c. Mineral fiber.
 2. Fire-rated insulation systems.
 3. Insulating cements.
 4. Adhesives.
 5. Mastics.
 6. Factory-applied jackets.
 7. Tapes.
 8. Securements.
- B. Exterior Ductwork: All exterior make up air ductwork shall be insulated with 2 inch thick, waterproof Polyisocyanurate insulation board with a resistance of R-10 or better. The insulating board shall be wrapped with a 20 mil thick waterproof exterior aluminum jacket with all seams lapped and sealed watertight with silicone or aluminum hard cast duct sealant.
- C. Insulate all heat pump refrigeration suction and liquid lines with flexible elastomeric pre-formed pipe insulation.
- D. Insulate all interior grease ducts with 3 inch thick fire duct wrap.
- E. Do not insulate exterior grease duct.

1.2 SUBMITTALS

- A. Product Data: For each type of product indicated.

1.3 QUALITY ASSURANCE

- A. Fire-Test-Response Characteristics: Insulation and related materials shall have fire-test-response characteristics indicated, as determined by testing identical products per ASTM E 84, by a testing and inspecting agency acceptable to authorities having jurisdiction. Factory label insulation and jacket materials and adhesive, mastic, tapes, and cement material containers, with appropriate markings of applicable testing and inspecting agency.
1. Insulation Installed Indoors: Flame-spread index of 25 or less, and smoke-developed index of 50 or less.

PART 2 - PRODUCTS**2.1 INSULATION MATERIALS**

- A. Polyisocyanurate closed-cell, rigid foam board: R-10, 2 inch thick insulation board bonded to facers on both sides, Inorganic, incombustible, foamed or cellulated glass with annealed, rigid, hermetically sealed cells.
1. Products: Subject to compliance with requirements, provide the following
 - a. R-max

2. Johns Manville ISOfoam APF board Preformed Insulation with Factory-Applied ASJ-SSL: Comply with ASTM C 552, Type II, Class 2.
- B. Flexible Elastomeric: Closed-cell, sponge- or expanded-rubber materials. Comply with ASTM C 534, Type I for tubular materials and Type II for sheet materials.
 1. Products: Subject to compliance with requirements, provide the following
 - a. Aeroflex USA Inc.; Aerocel.
 - b. Armacell LLC; AP Armaflex.
 - c. RBX Corporation; Insul-Sheet 1800 and Insul-Tube 180.
- C. Mineral-Fiber Blanket Insulation: Mineral or glass fibers bonded with a thermosetting resin. Comply with ASTM C 553, Type II and ASTM C 1290, Type I with factory-applied jacket
 1. Products: Subject to compliance with requirements, provide the following
 - a. CertainTeed Corp.; Duct Wrap.
 - b. Johns Manville; Microlite.
 - c. Knauf Insulation; Duct Wrap.
 - d. Owens Corning; All-Service Duct Wrap.
 - e.
- D. Mineral-Fiber, Preformed Pipe Insulation:
 1. Products: Subject to compliance with requirements, provide the following
 - a. Johns Manville; Micro-Lok.
 - b. Knauf Insulation; 1000 Pipe Insulation.
 - c. Manson Insulation Inc.; Alley-K.
 - d. Owens Corning; Fiberglas Pipe Insulation.

2.2 FIRE-RATED INSULATION SYSTEMS

- A. Fire-Rated Blanket: High-temperature, flexible, blanket insulation with FSK jacket that is tested and certified to provide a 1 hour fire rating by a NRTL acceptable to authority having jurisdiction.
 1. Products: Subject to compliance with requirements, provide the following
 - a. CertainTeed Corp.; FlameChek.
 - b. Johns Manville; Firetemp Wrap.
 - c. Thermal Ceramics; FireMaster Duct Wrap.
 - d. 3M; Fire Barrier Wrap Products.

2.3 INSULATING CEMENTS

- A. Mineral-Fiber, Hydraulic-Setting Insulating and Finishing Cement: Comply with ASTM C 449/C 449M.

2.4 ADHESIVES

- A. Materials shall be compatible with insulation materials, jackets, and substrates and for bonding insulation to itself and to surfaces to be insulated, unless otherwise indicated.
- B. Cellular-Glass, Phenolic, Polyisocyanurate, and Polystyrene Adhesive: Solvent-based resin adhesive, with a service temperature range of minus 75 to plus 300 deg F
- C. Flexible Elastomeric and Polyolefin Adhesive: Comply with MIL-A-24179A, Type II, Class I.
- D. Mineral-Fiber Adhesive: Comply with MIL-A-3316C, Class 2, Grade A.
- E. ASJ Adhesive, and FSK and PVDC Jacket Adhesive: Comply with MIL-A-3316C, Class 2, Grade A for bonding insulation jacket lap seams and joints.
- F. Aluminum Jacket: Comply with ASTM B 209 Alloy 3003, 3005, 3105 or 5005, Temper H-14.

2.5 TAPES

- A. ASJ Tape: White vapor-retarder tape matching factory-applied jacket with acrylic adhesive, complying with ASTM C 1136.
- B. FSK Tape: Foil-face, vapor-retarder tape matching factory-applied jacket with acrylic adhesive; complying with ASTM C 1136.
- C. PVC Tape: White vapor-retarder tape matching field-applied PVC jacket with acrylic adhesive. Suitable for indoor and outdoor applications.
- D. Aluminum-Foil Tape: Vapor-retarder tape with acrylic adhesive.

2.6 SECUREMENTS

- A. Aluminum Bands: ASTM B 209 Alloy 3003, 3005, 3105, or 5005; Temper H-14, 0.020 inch thick, 1/2 inch wide
- B. Insulation Pins and Hangers:
 - 1. Metal, Adhesively Attached, Perforated-Base Insulation Hangers: Baseplate welded to projecting spindle that is capable of holding insulation, of thickness indicated, securely in position indicated when self-locking washer is in place. Comply with the following requirements:
 - 2. Insulation-Retaining Washers: Self-locking washers formed from 0.016-inch- thick, galvanized-steel sheet, with beveled edge sized as required to hold insulation securely in place but not less than 1-1/2 inches in diameter.
 - a. Protect ends with capped self-locking washers incorporating a spring steel insert to ensure permanent retention of cap in exposed locations.
- C. Staples: Outward-clinching insulation staples, nominal 3/4-inch- (19-mm-) wide, stainless steel or Monel..

PART 3 - EXECUTION

3.1 GENERAL INSTALLATION REQUIREMENTS

- A. All exterior rectangular and square make up air ducts shall be insulated with 2 inch thick Polyisocyanurate closed-cell, rigid duct board and jacketed with 20 mil aluminum jacket. Board shall be secured to the duct with mechanical fasteners and adhesive, either impact-driven or weld-secured. The insulating board shall be wrapped with a 20 mil thick waterproof exterior aluminum jacket with all seams lapped and sealed watertight with silicone or aluminum hard cast duct sealant.
- B. All interior grease ducts shall be wrapped with 3 inches of high-temperature, flexible, blanket insulation and sealed with aluminum duct tape.
- C. Insulate all interior and exterior refrigeration piping with flexible elastomeric pipe insulation equal to Armaflex. Tape all joints. Paint exterior pipe insulation with two coats of white UV resistant paint.
- D. Install insulation materials, accessories, and finishes with smooth, straight, and even surfaces; free of voids throughout the length of equipment, ducts and fittings, and piping including fittings, valves, and specialties.

- E. Install sealants and tape compatible with insulation materials and suitable for the service. Install accessories that do not corrode, soften, or otherwise attack insulation or jacket in either wet or dry state.
- F. Install insulation with longitudinal seams at top and bottom of horizontal runs.
- G. Install multiple layers of insulation with longitudinal and end seams staggered.
- H. Install insulation with tight longitudinal seams and end joints. Bond seams and joints with adhesive recommended by insulation material manufacturer.
- I. Install insulation with least number of joints practical.
- J. Apply adhesives, mastics, and sealants at manufacturer's recommended coverage rate and wet and dry film thicknesses.
- K. Install insulation with factory-applied jackets as follows:
 - 1. Draw jacket tight and smooth.
 - 2. Cover circumferential joints with 3-inch- wide strips, of same material as insulation jacket. Cover joints and seams with tape as recommended by insulation material manufacturer to maintain vapor seal.
 - 3. Where vapor barriers are indicated, apply vapor-barrier mastic on seams and joints and at ends adjacent to duct and pipe flanges and fittings.
- L. Cut insulation in a manner to avoid compressing insulation more than 75 percent of its nominal thickness.
- M. Finish installation with systems at operating conditions. Repair joint separations and cracking due to thermal movement.
- N. Repair damaged insulation facings by applying same facing material over damaged areas. Extend patches at least 4 inches beyond damaged areas. Adhere, staple, and seal patches similar to butt joints.

3.2 PENETRATIONS

- A. Insulation Installation at Roof Penetrations: Install insulation continuously through roof penetrations.
 - 1. Seal penetrations with flashing sealant.
 - 2. For applications requiring only indoor insulation, terminate insulation above roof surface and seal with joint sealant. For applications requiring indoor and outdoor insulation, install insulation for outdoor applications tightly joined to indoor insulation ends. Seal joint with joint sealant.
 - 3. Extend jacket of outdoor insulation outside roof flashing at least 2 inches below top of roof flashing.
 - 4. Seal jacket to roof flashing with flashing sealant.
- B. Insulation Installation at Interior Wall and Partition Penetrations (That Are Not Fire Rated): Install insulation continuously through walls and partitions.
- C. Insulation Installation at Fire-Rated Wall and Partition Penetrations: Install insulation continuously through penetrations of fire-rated walls and partitions. Terminate insulation at fire damper sleeves for fire-rated wall and partition penetrations. Externally insulate damper sleeves to match adjacent insulation and overlap duct insulation at least 2 inches

3.3 GENERAL PIPE INSULATION INSTALLATION

- A. Insulate all refrigeration suction and liquid piping.
- B. Insulation Installation on Fittings, Valves, Strainers, Flanges, and Unions:
1. Install insulation over fittings, valves, strainers, flanges, unions, and other specialties with continuous thermal and vapor-retarder integrity, unless otherwise indicated.
 2. Insulate pipe elbows using preformed fitting insulation or mitered fittings made from same material and density as adjacent pipe insulation. Each piece shall be butted tightly against adjoining piece and bonded with adhesive. Fill joints, seams, voids, and irregular surfaces with insulating cement finished to a smooth, hard, and uniform contour that is uniform with adjoining pipe insulation.
 3. Insulate tee fittings with preformed fitting insulation or sectional pipe insulation of same material and thickness as used for adjacent pipe. Cut sectional pipe insulation to fit. Butt each section closely to the next and hold in place with tie wire. Bond pieces with adhesive.
 4. Insulate valves using preformed fitting insulation or sectional pipe insulation of same material, density, and thickness as used for adjacent pipe. Overlap adjoining pipe insulation by not less than two times the thickness of pipe insulation, or one pipe diameter, whichever is thicker. For valves, insulate up to and including the bonnets, valve stuffing-box studs, bolts, and nuts. Fill joints, seams, and irregular surfaces with insulating cement.
 5. Insulate strainers using preformed fitting insulation or sectional pipe insulation of same material, density, and thickness as used for adjacent pipe. Overlap adjoining pipe insulation by not less than two times the thickness of pipe insulation, or one pipe diameter, whichever is thicker. Fill joints, seams, and irregular surfaces with insulating cement. Insulate strainers so strainer basket flange or plug can be easily removed and replaced without damaging the insulation and jacket. Provide a removable reusable insulation cover. For below ambient services, provide a design that maintains vapor barrier.
 6. Insulate flanges and unions using a section of oversized preformed pipe insulation. Overlap adjoining pipe insulation by not less than two times the thickness of pipe insulation, or one pipe diameter, whichever is thicker.
 7. Cover segmented insulated surfaces with a layer of finishing cement and coat with a mastic. Install vapor-barrier mastic for below ambient services and a breather mastic for above ambient services. Reinforce the mastic with fabric-reinforcing mesh. Trowel the mastic to a smooth and well-shaped contour.
- C. Install removable insulation covers at locations indicated. Installation shall conform to the following:
1. Make removable flange and union insulation from sectional pipe insulation of same thickness as that on adjoining pipe. Install same insulation jacket as adjoining pipe insulation.
 2. When flange and union covers are made from sectional pipe insulation, extend insulation from flanges or union long at least two times the insulation thickness over adjacent pipe insulation on each side of flange or union. Secure flange cover in place with stainless-steel or aluminum bands. Select band material compatible with insulation and jacket.

3.4 CELLULAR-GLASS INSULATION INSTALLATION

- A. Insulation Installation on Straight Pipes and Tubes:
1. Secure each layer of insulation to pipe with wire or bands and tighten bands without deforming insulation materials.
 2. Where vapor barriers are indicated, seal longitudinal seams, end joints, and protrusions with vapor-barrier mastic and joint sealant.
 3. For insulation with factory-applied jackets on above ambient services, secure laps with outward clinched staples at 6 inches o.c.

- B. Insulation Installation on Pipe Fittings and Elbows:
 - 1. Install preformed sections of same material as straight segments of pipe insulation when available. Secure according to manufacturer's written instructions.
 - 2. When preformed sections of insulation are not available, install mitered sections of cellular-glass insulation. Secure insulation materials with wire or bands.
- C. Insulation Installation on Valves and Pipe Specialties:
 - 1. Install preformed sections of cellular-glass insulation to valve body.
 - 2. Arrange insulation to permit access to packing and to allow valve operation without disturbing insulation.
 - 3. Install insulation to flanges as specified for flange insulation application.

3.5 FLEXIBLE ELASTOMERIC INSULATION INSTALLATION

- A. Seal longitudinal seams and end joints with manufacturer's recommended adhesive to eliminate openings in insulation that allow passage of air to surface being insulated.
- B. Insulation Installation on Pipe Fittings and Elbows:
 - 1. Install mitered sections of pipe insulation.
 - 2. Secure insulation materials and seal seams with manufacturer's recommended adhesive to eliminate openings in insulation that allow passage of air to surface being insulated.
- C. Insulation Installation on Valves and Pipe Specialties:
 - 1. Install preformed valve covers manufactured of same material as pipe insulation when available.
 - 2. When preformed valve covers are not available, install cut sections of pipe and sheet insulation to valve body. Arrange insulation to permit access to packing and to allow valve operation without disturbing insulation.
 - 3. Install insulation to flanges as specified for flange insulation application.
 - 4. Secure insulation to valves and specialties and seal seams with manufacturer's recommended adhesive to eliminate openings in insulation that allow passage of air to surface being insulated.

3.6 MINERAL-FIBER INSULATION INSTALLATION

- A. Insulation Installation on Straight Pipes and Tubes:
 - 1. Secure each layer of preformed pipe insulation to pipe with wire or bands and tighten bands without deforming insulation materials.
 - 2. Where vapor barriers are indicated, seal longitudinal seams, end joints, and protrusions with vapor-barrier mastic and joint sealant.
 - 3. For insulation with factory-applied jackets on above ambient surfaces, secure laps with outward clinched staples at 6 inches o.c.
 - 4. For insulation with factory-applied jackets on below ambient surfaces, do not staple longitudinal tabs but secure tabs with additional adhesive as recommended by insulation material manufacturer and seal with vapor-barrier mastic and flashing sealant.
- B. Insulation Installation on Pipe Fittings and Elbows:
 - 1. Install preformed sections of same material as straight segments of pipe insulation when available.
 - 2. When preformed insulation elbows and fittings are not available, install mitered sections of pipe insulation, to a thickness equal to adjoining pipe insulation. Secure insulation materials with wire or bands.
- C. Insulation Installation on Valves and Pipe Specialties:
 - 1. Install preformed sections of same material as straight segments of pipe insulation when available.

2. When preformed sections are not available, install mitered sections of pipe insulation to valve body.
3. Arrange insulation to permit access to packing and to allow valve operation without disturbing insulation.
4. Install insulation to flanges as specified for flange insulation application.

- D. Blanket Insulation Installation on Ducts and Plenums: Secure with adhesive and insulation pins.
1. Apply adhesives according to manufacturer's recommended coverage rates per unit area, for 100 percent coverage of duct and plenum surfaces.
 2. Apply adhesive to entire circumference of ducts and to all surfaces of fittings and transitions.
 3. Install either capacitor-discharge-weld pins and speed washers or cupped-head, capacitor-discharge-weld pins on sides and bottom of horizontal ducts and sides of vertical ducts as follows:
 - a. On duct sides with dimensions 18 inches and smaller, place pins along longitudinal centerline of duct. Space 3 inches maximum from insulation end joints, and 16 inches o.c.
 - b. On duct sides with dimensions larger than 18 inches place pins 16 inches o.c. each way, and 3 inches maximum from insulation joints. Install additional pins to hold insulation tightly against surface at cross bracing.
 - c. Pins may be omitted from top surface of horizontal, rectangular ducts and plenums.
 - d. Do not overcompress insulation during installation.
 - e. Impale insulation over pins and attach speed washers.
 - f. Cut excess portion of pins extending beyond speed washers or bend parallel with insulation surface. Cover exposed pins and washers with tape matching insulation facing.
 4. For ducts and plenums with surface temperatures below ambient, install a continuous unbroken vapor barrier. Create a facing lap for longitudinal seams and end joints with insulation by removing 2 inches from 1 edge and 1 end of insulation segment. Secure laps to adjacent insulation section with 1/2-inch outward-clinching staples, 1 inch o.c.

3.7 FIRE-RATED INSULATION SYSTEM INSTALLATION

- A. Where fire-rated insulation system is indicated, secure system to pipe and pipe hangers and supports to maintain a continuous fire rating.

3.8 FIELD QUALITY CONTROL

- A. Perform tests and inspections.
- B. All insulation applications will be considered defective Work if sample inspection reveals noncompliance with requirements.

3.9 DUCT INSULATION SCHEDULE, GENERAL

- A. Ducts Requiring Insulation:
1. Interior and exterior make up air ducts.
 2. Indoor, exposed supply and outdoor air unless otherwise noted.
 3. Interior exhaust ducts. Except grease or dishwasher exhaust.
 4. Grease ducts. Fire rated duct wrap.

3.10 PIPE INSULATION SCHEDULE, GENERAL

- A. Pipes Requiring Insulation:
1. Indoor, exposed and concealed refrigeration piping.
 2. Outdoor, exposed refrigeration piping.

3.11 INDOOR DUCT INSULATION SCHEDULE

- A. Concealed, Exhaust-Air Duct and Plenum Insulation: Mineral-fiber blanket, 1-1/2 inches thick nominal density.
- B. Concealed, Grease Duct Insulation: Fire wrap blanket, 3 inches thick nominal density.
- C. Concealed, Make Up-Air Duct Insulation: Mineral-fiber blanket, 1-1/2 inches thick nominal density.

3.12 OUTDOOR DUCT INSULATION SCHEDULE

- A. Exposed, Make Up-Air Duct Insulation: Polyisocyanurate closed-cell, rigid duct board, 2 inches thick with 20 mil aluminum jacket finish .

3.13 PIPING INSULATION SCHEDULE, GENERAL

- A. Acceptable preformed pipe and tubular insulation materials and thicknesses are identified for each piping system and pipe size range. If more than one material is listed for a piping system, selection from materials listed is Contractor's option.

3.14 INDOOR PIPE INSULATION SCHEDULE

- A. Concealed, Refrigeration Piping. Insulation: Preformed Flexible Elastomeric Pipe insulation. 1 inches thick.
- B. Exterior, Refrigeration Piping. Insulation: Preformed Flexible Elastomeric Pipe insulation. 1 inches thick with two coats UV resistant paint or aluminum jacket.

END OF SECTION 230700

SECTION 23 0900 - INSTRUMENTATION AND CONTROL FOR HVAC

PART 1 - GENERAL

1.1 SUMMARY

A. This Section includes control equipment for HVAC systems and components, including control components for factory heat pump heating and cooling systems with factory-wired controls.

B. Provide the following:

Local DDC Control Panels
ATC Interface Panels
Room Temperature and Fan Control
Building Fire Alarm Interlocks

C. Indoor VRF Unit:

1. Occupied Time Schedule:

- a. Input Device: DDC system time schedule.
- b. Output Device: Binary output.
- c. Action: Start and stop fan, and enable control.

2. Room Temperature:

- a. Input Device: Room thermostat or controller
- b. Output Device: Electronic control-valve operators.
- c. Action: Modulate multiport control valves to maintain temperature.

3. Display:

- a. DDC system graphic.
- b. DDC system on-off indication.
- c. DDC system occupied/unoccupied mode.
- d. Room temperature indication.
- e. Room temperature set point.
- f. Control-valve position.

1.2 SYSTEM DESCRIPTION:

A. A system of DDC automatic temperature controls shall be furnished and installed as a part of this contract to give the owner a completely operable system for monitoring and controlling the heat pump system. Acceptable manufacturer and installer shall be: TAC, as supplied and installed by Utah/Yamas Controls to remain consistent with the district wide automation system.

B. Heat pump systems control shall be BACnet compatible and configured and connected to the district Network. System shall be accessible from any remote site through an internet connection.

C. Heat pump control systems shall be supplied and installed by the heat pump manufacturer. Acceptable manufacturers include Mitsubishi, LG and Daiken. The ATC contractor shall work closely with the Heat Pump Manufacturer to provide monitoring and control of the Heat Pump system.

- D. Kitchen Make Up Air and Kitchen Hood Exhaust Systems including interlocks and fire alarm shutdown.
- E. Dishwasher Hood Exhaust.
- F. The entire building automation system shall tie into the Ogden School District Lan Network. The ATC contractor shall include all software and hardware to permit district wide network and complete intranet access to the DDC system.
- G. The system shall be as indicated on the drawings and specified herein. Building HVAC systems and unitary heating devices shall be entirely controlled by the DDC system. System shall include local DDC controllers mounted at each heat pump or fan system. These local DDC controllers shall be interconnected by a 2-wire or 3-wire LAN.
- H. The master/central DDC controller, in turn, shall communicate with the existing school district host computer located in the district offices.
- I. The DDC/Energy Management system will have dynamic alarm display capability. If an alarm should occur at a remote location or system, that alarm shall generate a message on whatever screen happens to be on the current display. All alarms shall be logged on the system printer. The system will be capable of printing logs and trends. It will also be capable of displaying graphic trend information for all points.

1.3 WORK TO BE PERFORMED BY OTHERS

- A. The ATC contractor is required to supply and install a complete 100% conduit system for the DDC control system in the remodeled area. Plenum rated cable is acceptable means of installation above ceilings. Refer to the Installation by the ATC contractor section in this specification for installation requirements.
- B. Division 26 shall furnish and install all single phase and multiple phase electrical power wiring to magnetic starters, disconnect switches, and motors. Division 26 shall also provide 120 VAC, 20 Ampere power sources to each group of ATC panels. The ATC contractor shall be responsible for all step down transformers and 24 VAC wiring to ATC equipment.
- C. The mechanical contractor shall install all valves, immersion wells and pressure taps supplied him by the ATC contractor.

1.4 INSTALLATION BY AUTOMATIC TEMPERATURE CONTROL (ATC) CONTRACTOR

- A. The successful control contractor shall furnish and install all necessary electrical control wiring and conduit for the complete temperature control system, heating and ventilating equipment motor starting circuit controls and all electrical control interlocks for same, and for control wiring for miscellaneous HVAC equipment furnished by the Owner.
- B. The ATC contractor shall furnish & install all necessary electrical control wiring and conduit of all temperature controls, heating and ventilating equipment motor starting circuit controls, all electrical control interlocks for same and for miscellaneous packaged equipment.
- C. All line and low voltage electrical and control wiring in walls shall be installed in EMT conduit & in accordance with the National Electrical Code and applicable local codes and in accordance with Division 26 of this specification. 3/4" nominal trade conduit shall be installed. Plenum cable may be installed above accessible ceiling areas. All cable must be neatly installed and adequately supported..

- D. All ATC rough-in boxes shall be identified with the letters "ATC" written across the inside of the box. In addition, each ATC cover plate shall be painted white with the letters "ATC" stenciled in black.

1.5 SUBMITTALS

- A. Product Data: For each control device indicated.
- B. Submit shop drawings (6 sets) and manufacturer's data for the following items to the mechanical engineer:
 - C. Wiring and installation diagrams. ATC device specification sheets
 - D. Control flow diagrams, complete with all control schematics and sequences of operation.

1.6 QUALITY ASSURANCE

- A. Electrical Components, Devices, and Accessories: Listed and labeled as defined in NFPA 70, Article 100, by a testing agency acceptable to authorities having jurisdiction, and marked for intended use.
- B. Provide an unconditional TWO-YEAR parts and service warranty. This warranty shall commence at the time of substantial completion of the various portions of the system.

1.7 PROJECT COMPLETION REQUIREMENTS

- A. Engage a factory-authorized service representative to train Owner's maintenance personnel to adjust, operate, and maintain HVAC instrumentation and controls.

PART 2 - PRODUCTS

2.1 MANUFACTURERS

- A. Manufacturers:
 - 1. Controls Systems International by Utah Yamas Inc
 - 2. Heat Pump VRF Systems Control: Mitsubishi, LG or Daiken.
- B. Control system shall consist of programmable devices and other apparatus, and accessories to control roof top VRF heat pump system, interior evaporator units systems with interface for heating, cooling, ventilation control.
- C. All DDC input devices shall provide industry standard signals and shall be compatible with the DDC controllers used.
- D. All temperature input devices shall have a rated accuracy of 1% or better.

2.2 DDC OUTPUTS

- A. Modulating outputs shall be in accordance with industry standards and shall be compatible with the driven DDC devices.
- B. Outputs shall be 0-10 VAC/VOC or 0.5 sec - 5.0 sec. 4-20 MA.

2.3 CONTROL CABLE

- A. Electronic and fiber-optic cables for control wiring are specified in Division 27 Section "Communications Horizontal Cabling."

2.4 DUCT SMOKE DETECTORS

- A. Duct smoke detectors are to be furnished and wired by Division 26. Detectors shall be installed by the ATC contractor.
- B. Division 26 shall furnish & install a fire alarm/fan shutdown relay at each fan system.
- C. The ATC contractor shall wire between the alarm relay contacts and the makeup air fan system starter to lock out the fan when the building is in fire alarm.
- D. Shutdown relay shall be wired to allow monitoring by the DDC System.

2.5 MOTORIZED ATC DAMPERS

- A. Motorized control dampers that are not supplied with the make up air units shall be furnished by the Automatic Temperature Control Contractor. Dampers shall be factory-built, low leakage units such as Ruskin CD-50 or approved equal. Blades shall be 6" maximum width, 6063-T5 extruded aluminum width, 1/2" axles, and Oilite or Cycology bearings.
- B. Dampers shall be low leakage type with compressible end seals and neoprene or extruded vinyl blade and jamb seals. Leakage shall not exceed 6.2 cfm/sq. ft. at 4" W.G. Dampers shall require less than 7#-in/sq. ft. torque at the operating shaft for proper operation.
- C. Outdoor air dampers shall be parallel blade with blade direction oriented to assist mixing of air streams with spring return to fail closed. Relief air and other volume control dampers shall be opposed blade.

2.6 DAMPER ACTUATORS

- A. Damper actuators shall be of the gear-train type. All moving parts shall be permanently lubricated and not require addition or replacement of oil. Actuators shall meet the NEMA 3R rainproof rating and shall have an ambient temperature operating rating of -40°F to 140°F, without the addition of extra equipment. Actuators shall also carry the UL 94-5V rating for installation in return air plenums.
- B. Damper actuators linked to outdoor air dampers shall close their attached dampers upon power failure or fan shutdown by means of a mechanical spring return.
- C. Actuator manufacturers shall be Belimo or Honeywell. No substitutions.

2.7 HEAT PUMP ROOM THERMOSTATS AND FAN CONTROLLERS

- A. Wall-mounted space temperature thermostat and fan controller provided and installed by the Heat Pump manufacturer. Hard wired to control the respective interior heat pump evaporators and their respective fans in addition to controlling the exterior heat pump and control solenoid box for heating and cooling. Thermostats shall have an adjustment dial or digital screen that can be given a programmable setpoint along with variable fan speed selections for fan speed control.

2.8 LOCAL DDC CONTROL PANELS

- A. Local DDC control panels shall be located near mechanical systems as necessary to provide both digital and analog input and output points as specified and/or required to achieve specified system performance.

2.9 ATC INTERFACE PANELS

- A. ATC interface panels shall be mounted in the mechanical storage closet. Each panel shall be made of not less than 16 gage steel. Panel shall have a full back plate and full hinged door such that when the door is closed, the assembly provides a completely enclosed, NEMA 1 enclosure. Panels shall be fully painted and fitted with key locks. Appropriately sized nameplates shall be used to identify all panel mounted devices.

- B. Panels shall contain the following devices as applicable:

1. Control transformers
2. NEC required fusing
3. Local DDC controllers
4. NEC required grounding
5. Logic relays
6. Terminal wiring strips

2.10 LABELING

- A. All ATC supplied panels and devices shall be permanently labeled with engraved plastic laminate labels indicating device name, system identifier and function within the system.

PART 3 - EXECUTION

3.1 INSTALLATION

- A. Verify location of programmable devices with Drawings and room details before installation. Install sensors, thermostats and devices 54 inches above the floor.
- B. Install labels and nameplates at each thermostat and device to identify control components.
- C. Coordinate with the Heat Pump VRF supplier regarding the location, installation and monitoring of all heat pump controllers, sensors and devices.

3.2 ELECTRICAL WIRING AND CONNECTION INSTALLATION

- A. Install raceways, boxes, and cabinets according to Division 26 Section "Raceway and Boxes for Electrical Systems."
- B. Install building wire and cable according to Division 26 Section "Low-Voltage Electrical Power Conductors and Cables."
- C. Install signal and communication cable according to Division 27 Section "Communications Horizontal Cabling."

1. Conceal cable, except in mechanical rooms and areas where other conduit and piping are exposed.
 2. Install exposed cable in raceway.
 3. Install concealed cable in raceway.
 4. Bundle and harness multiconductor instrument cable in place of single cables where several cables follow a common path.
 5. Fasten flexible conductors, bridging cabinets and doors, along hinge side; protect against abrasion. Tie and support conductors.
 6. Number-code or color-code conductors for future identification and service of control system, except local individual room control cables.
 7. Install wire and cable with sufficient slack and flexible connections to allow for vibration of piping and equipment.
- D. Connect hand-off-auto selector switches to override automatic interlock controls when switch is in hand position.

3.3 GENERAL SYSTEM DESCRIPTION

- A. The mechanical heating and cooling systems for the kitchen area consist of an exterior roof mounted air cooled heat pump, refrigeration solenoid controller box, interior fan heating and cooling evaporators.
- B. The kitchen hood ventilation system is comprised of a roof mounted grease exhaust duct fan and a roof mounted, gas fired, evaporative cooled make up unit. The make up air unit is to be interlocked to provide constant volume make up air whenever the exhaust fan serving the kitchen hoods is activated.
- C. Ceiling mounted exhaust fans for ventilating restrooms
- D. Roof mounted dishwasher hood exhaust fan.
- E. Storage room heating and cooling heat pump unit.

3.4 SEQUENCE OF OPERATION

3.5 HEAT PUMP SYSTEM (HP-1)

- A. The heat pump systems consist of a roof mounted air cooled heat pump with interior wall mounted evaporator fan heat pump unit with individual DX coils and fan.
- B. The interior heat pump shall be started from a local thermostat and fan controller to provide heating and cooling of the space. The temperature setpoint and fan speed shall be adjustable from the face of the thermostat/fan speed controller.
- C. In operating mode the interior heat pump fans shall cycle on and the exterior heat pump unit shall be cycled on to maintain minimum space temperature heating and cooling setpoints. Fan shall run continuous.
- D. If the heat pump system is shut-down, or fails to start due to abnormal conditions, an alarm shall be sent to the DDC system. The DDC system shall monitor the operation of the heat pump control system.

3.6 HEAT PUMP SYSTEM (HP-2)

- A. The heat pump VRF systems consist of a roof mounted, variable flow refrigerant (VRF) air cooled heat pump with above ceiling mounted solenoid valved multizone controller for switching between

heating and cooling modes. In addition, the system consists of multizone interior wall mounted heat pump units with individual DX coils and fans.

- B. The interior wall heat pump shall be started from a local thermostat and fan controller to provide heating and cooling of the spaces they serve. The temperature setpoint and fan speed shall be adjustable from the face of the thermostat/fan speed controllers. The controllers shall be located in a convenient and operable locations, not adjacent to any kitchen equipment.
- C. In operating mode the interior heat pump fans shall cycle on and the exterior heat pump unit shall be cycled on to maintain minimum space temperature heating and cooling setpoints. Fans shall run continuous.
- D. The BC refrigeration controller shall be mounted above the ceiling and shall switch between heating and cooling mode as needed to automatically maintain setpoint temperatures of the various zones.
- E. If the heat pump system is shut-down, or fails to start due to abnormal conditions, an alarm shall be sent to the DDC system. The DDC system shall monitor the operation of the heat pump control system.

3.7 MAKE UP AIR SYSTEM (MAU-1):

- A. The roof mounted, gas fired, evaporative cooled make up air unit shall be interlocked to operate whenever the kitchen cooking hood system exhaust fan is energized.
- B. In operation mode, the motorized outside air damper on the make up air unit shall open to a full 100% open position to provide 100% outside air to the kitchen hood supply air ceiling plenum furnished with the kitchen hoods. The gas fired heating and the evaporative cooling systems furnished with the make up air unit acting through a logic controller shall start and stop the heating and cooling systems as needed to provide a discharge air setpoint temperature of 68 degrees(adjustable) to the kitchen hood supply air plenum.
- C. The ATC contractor shall furnish and install the discharge air setpoint sensor in the discharge air ductwork in a convenient and accessible location.
- D. The ATC contractor shall furnish and install the motorized outside air damper and actuator if not furnished with the Make Up Air Unit.
- E. When the exhaust fan serving the kitchen hoods is de- energized, the make up air unit shall be de-energized and the outside air damper shall close.
- F. The make up air unit system shall be interlocked with the kitchen hood and building fire alarm system to shut down in the event of alarm.

3.8 FIRE ALARM FAN SHUT-DOWN:

- A. All make up air supply fans shall automatically shut off when the building fire alarm system is energized. All fans to automatically start up again when fire alarm system is reset. Fire alarm system fan relays shall be "normally energized" and shall be installed by Division 26 at each fan system.

3.9 ELECTRIC UNIT HEATER CONTROL

- A. Entry Electric Unit Heater (EH-1): A localized low voltage wall mounted thermostat shall control the wall mounted electric unit heater to maintain space temperature. Upon a call for heat the electric unit heater shall energize the electric heating coils and integral supply air fan of the electric unit

heater. Unit heater fans shall run continuously whenever the electric heating elements are energized. When space temperature is satisfied, the electric unit heater shall be de-energized.

- B. Restroom Electric Unit Heater (EH-2): A localized low voltage wall mounted thermostat shall control the wall mounted electric unit heater to maintain space temperature. Upon a call for heat the electric unit heater shall energize the electric heating coils and integral supply air fan of the electric unit heater. Unit heater fans shall run continuously whenever the electric heating elements are energized. When space temperature is satisfied, the electric unit heater shall be de-energized.
- C. Storage Room Electric Unit Heater (EH-3): The electric unit heater shall be controlled from a wall mounted line voltage thermostat. When temperature inside the room drops below setpoint of 50 deg F (adjustable) the unit heater shall start and continue to run. Upon a call for heat the electric unit heater shall energize the electric heating coils and integral supply air fan. Unit heater fans shall run whenever the electric heating elements are energized. When space temperature is satisfied, the electric unit heater shall be de-energized.

3.10 EXHAUST FAN CONTROL

- A. Cooking Hood Exhaust Fan (EF-1). Roof mounted, constant volume, grease duct exhaust fan shall be controlled from a cooking hood mounted control panel. When the panel exhaust fan button is pushed the grease duct exhaust fan shall start and run continuously. The fan shall stop when the panel exhaust fan button is de-activated. The exhaust fan shall be interlocked with the makeup air unit (MAU-1) to operate simultaneously subject to cooking hood and building fire alarm status.
- B. Dishwasher Hood Exhaust Fan (EF-2). Roof mounted, constant volume exhaust fan shall be controlled from a on/off switch located on the fume hood front panel. When the fan switch is activated the motorized damper located near the roof curb shall open and the exhaust fan shall start and run continuous. When the fume hood fan control switch is de-energized the exhaust fan shall stop and the motorized damper shall close.
- C. Restroom Fan (EF-3). Ceiling mounted, rest room exhaust fans shall be controlled from a wall mounted digital timer line voltage switch equal to Leviton provided and installed by the ATC contractor. The digital timer shall have multiple time selection settings. When the timer is energized the exhaust fan shall start and run for the pre-set time limit.

3.11 AREA SECURITY TEMPERATURE ALARMS

- A. Temperature sensors located in the kitchen freezer and cooler shall continuously monitor the space temperature and alarm the building Host computer anytime the space temperature rises above preset setpoints. The Host computer shall then notify the District Remote Security Facility that an alarm has occurred.

END OF SECTION 23 0900

SECTION 23 1123 - FACILITY NATURAL-GAS PIPING**PART 1 - GENERAL****1.1 SUMMARY**

- A. Section Includes:
 - 1. Pipes, tubes, and fittings.
 - 2. Piping specialties.
 - 3. Piping and tubing joining materials.
 - 4. Valves.
 - 5. Pressure regulators.

1.2 PERFORMANCE REQUIREMENTS

- A. Minimum Operating-Pressure Ratings:
 - 1. Piping and Valves: 100 psig minimum unless otherwise indicated.
 - 2. Pressure Regulators: 65 psig minimum unless otherwise indicated.
- B. Natural-Gas System Pressure within Buildings: 2 psig regulated to 4 ounces at appliances.
- C. Delegated Design: Design restraints and anchors for natural-gas piping and equipment, including comprehensive engineering analysis by a qualified professional engineer, using performance requirements and design criteria indicated.
- D. Connect to existing gas piping system located in the crawl space.

1.3 SUBMITTALS

- A. Product Data: For each type of product indicated.
- B. Welding certificates.
- C. Field quality-control reports.
- D. Operation and maintenance data.

1.4 QUALITY ASSURANCE

- A. Steel Support Welding Qualifications: Qualify procedures and personnel according to AWS D1.1/D1.1M, "Structural Welding Code - Steel."
- B. Pipe Welding Qualifications: Qualify procedures and operators according to ASME Boiler and Pressure Vessel Code.
- C. Electrical Components, Devices, and Accessories: Listed and labeled as defined in NFPA 70, by a qualified testing agency, and marked for intended location and application.

PART 2 - PRODUCTS**2.1 PIPES, TUBES, AND FITTINGS**

- A. Steel Pipe: ASTM A 53/A 53M, black steel, Schedule 40, Type E or S, Grade B.
 - 1. Malleable-Iron Threaded Fittings: ASME B16.3, Class 150, standard pattern.

2. Wrought-Steel Welding Fittings: ASTM A 234/A 234M for butt welding and socket welding.
3. Unions: ASME B16.39, Class 150, malleable iron with brass-to-iron seat, ground joint, and threaded ends.
4. ALL 2 PSIG GAS PIPING INSTALLED IN CRAWL SPACE SHALL BE SOCKET WELDED

2.2 PIPING SPECIALTIES

A. Appliance Flexible Connectors:

1. Indoor, Fixed-Appliance Flexible Connectors: Comply with ANSI Z21.24.
2. Indoor, Movable-Appliance Flexible Connectors: Comply with ANSI Z21.69.
3. Corrugated stainless-steel tubing with polymer coating.
4. Operating-Pressure Rating: 0.5 psig
5. End Fittings: Zinc-coated steel.
6. Threaded Ends: Comply with ASME B1.20.1.

B. Y-Pattern Strainers:

1. Body: ASTM A 126, Class B, cast iron with bolted cover and bottom drain connection.
2. End Connections: Threaded ends for NPS 2 (DN 50) and smaller.
3. Strainer Screen: [40] [60]-mesh startup strainer, and perforated stainless-steel basket with 50 percent free area.
4. CWP Rating: 125 psig).

2.3 JOINING MATERIALS

A. Joint Compound and Tape: Suitable for natural gas.

B. Welding Filler Metals: Comply with AWS D10.12/D10.12M for welding materials appropriate for wall thickness and chemical analysis of steel pipe being welded.

2.4 VALVES

A. General Requirements for Metallic Valves, NPS 2 and Smaller: Comply with ASME B16.33.

B. Two-Piece, Full-Port, Bronze Ball Valves with Bronze Trim: MSS SP-110.

1. Manufacturers: Subject to compliance with requirements, provide products by one of the following
 - a. BrassCraft Manufacturing Company; a Masco company.
 - b. Conbraco Industries, Inc.; Apollo Div.
 - c. McDonald, A. Y. Mfg. Co.
2. Body: Bronze, complying with ASTM B 584.
3. Ball: Chrome-plated bronze.
4. Stem: Bronze; blowout proof.
5. Seats: Reinforced TFE; blowout proof.
6. Packing: Threaded-body packnut design with adjustable-stem packing.
7. Ends: Threaded, flared, or socket as indicated in "Underground Manual Gas Shutoff Valve Schedule" and "Aboveground Manual Gas Shutoff Valve Schedule" Articles.
8. CWP Rating: 600 psig
9. Listing: Valves NPS 1 and smaller shall be listed and labeled by an NRTL acceptable to authorities having jurisdiction.
10. Service: Suitable for natural-gas service with "WOG" indicated on valve body.

2.5 PRESSURE REGULATORS

A. Appliance Pressure Regulators: Comply with ANSI Z21.18.

1. Manufacturers: Subject to compliance with requirements, provide products by one of the following
 - a. Pietro Fiorentini.
 - b. Maxitrol Company.
 - c. SCP, Inc.
2. Body and Diaphragm Case: Die-cast aluminum.
3. Springs: Zinc-plated steel; interchangeable.
4. Diaphragm Plate: Zinc-plated steel.
5. Seat Disc: Nitrile rubber.
6. Seal Plug: Ultraviolet-stabilized, mineral-filled nylon.
7. Factory-Applied Finish: Minimum three-layer polyester and polyurethane paint finish.
8. Regulator may include vent limiting device, instead of vent connection, if approved by authorities having jurisdiction.
9. Maximum Inlet Pressure: 2 psig

2.6 DIELECTRIC UNIONS

- A. Minimum Operating-Pressure Rating: 150 psig
- B. Combination fitting of copper alloy and ferrous materials.
- C. Insulating materials suitable for natural gas.
- D. Combination fitting of copper alloy and ferrous materials with threaded, brazed-joint, plain, or welded end connections that match piping system materials.

2.7 PAINTING AND IDENTIFYING

- A. Label all interior and exterior gas piping with self sealing adhesive type pipe labels.
- B. Paint all exterior gas piping with two coats of Yellow enamel paint.

PART 3 - EXECUTION

3.1 INDOOR PIPING INSTALLATION

- A. Connect to existing 2 PSIG gas piping where indicated on the drawings. Field verify location of piping and gas service pressure prior to making connection.
- B. All 2 PSI gas pipe inside the building and inside the crawl space of the building shall be socket welded.
- C. Comply with NFPA 54 and the International Fuel Gas Code for installation and purging of natural-gas piping.
- D. Drawing plans, schematics, and diagrams indicate general location and arrangement of piping systems. Indicated locations and arrangements are used to size pipe and calculate friction loss, expansion, and other design considerations. Install piping as indicated unless deviations to layout are approved on Coordination Drawings.
- E. Install piping in crawl spaces and above accessible ceilings to allow sufficient space for ceiling panel removal.
- F. Locate valves for easy access.

- G. Drips and Sediment Traps: Install drips at points where condensate may collect. Locate where accessible to permit cleaning and emptying. Do not install where condensate is subject to freezing.
- H. Conceal pipe installations in walls, pipe spaces, utility spaces, above ceilings, below grade or floors, and in floor channels unless indicated to be exposed to view.
- I. Use eccentric reducer fittings to make reductions in pipe sizes. Install fittings with level side down.
- J. Connect branch piping from top or side of horizontal piping.
- K. Install unions in pipes NPS 2 and smaller, adjacent to each valve, at final connection to each piece of equipment.
- L. Do not use natural-gas piping as grounding electrode.
- M. Install strainer on inlet of each line-pressure regulator and automatic or electrically operated valve.
- N. Install gas pressure limiter and non-venting gas pressure regulator at each gas fired appliance. Regulate gas pressure at each appliance to comply with manufacturers recommendations.
- O. Install isolation ball valves at each appliance for servicing.
- P. Make required gas line connections to all service equipment with flexible gas connectors and shut-off valves.

3.2 VALVE INSTALLATION

- A. Install manual gas shutoff valve for each gas appliance ahead of corrugated stainless-steel tubing or copper connector.
- B. Install regulators and overpressure protection devices with maintenance access space adequate for servicing and testing.

3.3 PIPING JOINT CONSTRUCTION

- A. Ream ends of pipes and tubes and remove burrs.
- B. Remove scale, slag, dirt, and debris from inside and outside of pipe and fittings before assembly.
- C. Threaded Joints (1 PSIG or Less):
 - 1. Thread pipe with tapered pipe threads complying with ASME B1.20.1.
 - 2. Cut threads full and clean using sharp dies.
 - 3. Ream threaded pipe ends to remove burrs and restore full inside diameter of pipe.
 - 4. Apply appropriate tape or thread compound to external pipe threads unless dryseal threading is specified.
 - 5. Damaged Threads: Do not use pipe or pipe fittings with threads that are corroded or damaged. Do not use pipe sections that have cracked or open welds.
- D. Welded Joints (2 PSIG or greater):
 - 1. Construct joints according to AWS D10.12/D10.12M, using qualified processes and welding operators.
 - 2. Bevel plain ends of steel pipe.

3. Patch factory-applied protective coating as recommended by manufacturer at field welds and where damage to coating occurs during construction.

3.4 CONNECTIONS

- A. Install natural-gas piping electrically continuous, and bonded to gas appliance equipment grounding conductor of the circuit powering the appliance according to NFPA 70.
- B. Install piping adjacent to appliances to allow service and maintenance of appliances.
- C. Connect piping to appliances using manual gas shutoff valves and unions. Install valve within 72 inches of each gas-fired appliance and equipment. Install union between valve and appliances or equipment.
- D. Sediment Traps: Install tee fitting with capped nipple in bottom to form drip, as close as practical to inlet of each appliance.

3.5 LABELING AND IDENTIFYING.

- A. Paint and label all new gas piping as specified above.
- B. Gas piping exposed to outdoors shall be painted with two coats of Yellow enamel paint and labeled with appropriate gas labels.

3.6 FIELD QUALITY CONTROL

- A. Test, inspect, and purge natural gas according to International Fuel Gas Code and authorities having jurisdiction.
- B. Natural-gas piping will be considered defective if it does not pass tests and inspections.
- C. Prepare test and inspection reports.

END OF SECTION 23 1123

SECTION 23 2300 - REFRIGERANT PIPING

PART 1 - GENERAL

1.1 SUMMARY

- A. This Section includes refrigerant piping used for heat pump and air-conditioning applications.

1.2 PERFORMANCE REQUIREMENTS

- A. Line Test Pressure for Refrigerant R-410A:
 - 1. Suction Lines for Air-Conditioning Applications: 550 psig positive pressure and 1500 microns negative pressure.
 - 2. Hot-Gas and Liquid Lines: 550 psig positive pressure and 1500 microns negative pressure.
- B. Refrigerant piping systems shall be subjected to both positive and negative pressure testing as noted above for a period not less than 24 hours.

1.3 SUBMITTALS

- A. Product Data: For each type of valve and refrigerant piping specialty indicated. Include pressure drop based on manufacturer's test data.
- B. Refrigeration Box Controllers furnished with the Heat Pump System.
- C. Shop Drawings: Show layout of refrigerant piping and specialties, including pipe, tube, and fitting sizes, flow capacities, valve arrangements and locations, slopes of horizontal runs, oil traps, double risers, wall and floor penetrations, and equipment connection details. Show interface and spatial relationships between piping and equipment.
 - 1. Refrigerant piping indicated on Drawings is schematic only. Size piping and design actual piping layout, including oil traps, double risers, specialties, and pipe and tube sizes to accommodate, as a minimum, equipment provided, elevation difference between compressor and evaporator, and length of piping to ensure proper operation and compliance with warranties of connected equipment.
- D. Field quality-control test reports.
- E. Operation and maintenance data.

1.4 QUALITY ASSURANCE

- A. Comply with ASHRAE 15, "Safety Code for Refrigeration Systems."
- B. Comply with ASME B31.5, "Refrigeration Piping and Heat Transfer Components."

1.5 PRODUCT STORAGE AND HANDLING

- A. Store piping in a clean and protected area with end caps in place to ensure that piping interior and exterior are clean when installed.

PART 2 - PRODUCTS

2.1 COPPER TUBE AND FITTINGS

- A. Copper Tube: ASTM B 88, Type L
- B. Wrought-Copper Fittings: ASME B16.22.
- C. Wrought-Copper Unions: ASME B16.22.
- D. Brazing Filler Metals: AWS A5.8.
- E. Flexible Connectors:
 1. Body: Tin-bronze bellows with woven, flexible, tinned-bronze-wire-reinforced protective jacket.
 2. End Connections: Socket ends.
 3. Offset Performance: Capable of minimum 3/4-inch misalignment in minimum 7-inch- long assembly.
 4. Pressure Rating: Factory test at minimum 500 psig
 5. Maximum Operating Temperature: 250 deg F

2.2 VALVES AND SPECIALTIES

- A. Diaphragm Packless Valves:
 1. Body and Bonnet: Forged brass or cast bronze; globe design with straight-through or angle pattern.
 2. Diaphragm: Phosphor bronze and stainless steel with stainless-steel spring.
 3. Operator: Rising stem and hand wheel.
 4. Seat: Nylon.
 5. End Connections: Socket, union, or flanged.
 6. Working Pressure Rating: 500 psig
 7. Maximum Operating Temperature: 275 deg F
- B. Packed-Angle Valves:
 1. Body and Bonnet: Forged brass or cast bronze.
 2. Packing: Molded stem, back seating, and replaceable under pressure.
 3. Operator: Rising stem.
 4. Seat: Nonrotating, self-aligning polytetrafluoroethylene.
 5. Seal Cap: Forged-brass or valox hex cap.
 6. End Connections: Socket, union, threaded, or flanged.
 7. Working Pressure Rating: 500 psig
 8. Maximum Operating Temperature: 275 deg F
- C. Check Valves:
 1. Body: Ductile iron, forged brass, or cast bronze; globe pattern.
 2. Bonnet: Bolted ductile iron, forged brass, or cast bronze; or brass hex plug.
 3. Piston: Removable polytetrafluoroethylene seat.
 4. Closing Spring: Stainless steel.

5. Manual Opening Stem: Seal cap, plated-steel stem, and graphite seal.
 6. End Connections: Socket, union, threaded, or flanged.
 7. Maximum Opening Pressure: 0.50 psig
 8. Working Pressure Rating: 500 psig
 9. Maximum Operating Temperature: 275 deg F
- D. Service Valves:
1. Body: Forged brass with brass cap including key end to remove core.
 2. Core: Removable ball-type check valve with stainless-steel spring.
 3. Seat: Polytetrafluoroethylene.
 4. End Connections: Copper spring.
 5. Working Pressure Rating: 500 psig
- E. Solenoid Valves: Comply with ARI 760 and UL 429; listed and labeled by an NRTL.
1. Body and Bonnet: Plated steel.
 2. Solenoid Tube, Plunger, Closing Spring, and Seat Orifice: Stainless steel.
 3. Seat: Polytetrafluoroethylene.
 4. End Connections: Threaded.
 5. Working Pressure Rating: 400 psig
 6. Maximum Operating Temperature: 240 deg F
- F. Safety Relief Valves: Comply with ASME Boiler and Pressure Vessel Code; listed and labeled by an NRTL.
1. Body and Bonnet: Ductile iron and steel, with neoprene O-ring seal.
 2. Piston, Closing Spring, and Seat Insert: Stainless steel.
 3. Seat Disc: Polytetrafluoroethylene.
 4. End Connections: Threaded.
 5. Working Pressure Rating: 400 psig
 6. Maximum Operating Temperature: 240 deg F
- G. Thermostatic Expansion Valves: Comply with ARI 750.
1. Body, Bonnet, and Seal Cap: Forged brass or steel.
 2. Diaphragm, Piston, Closing Spring, and Seat Insert: Stainless steel.
 3. Packing and Gaskets: Non-asbestos.
 4. Capillary and Bulb: Copper tubing filled with refrigerant charge.
 5. Suction Temperature: 40 deg F.
 6. Superheat: Adjustable
 7. End Connections: Socket, flare, or threaded union.
 8. Working Pressure Rating: 700 psig
- H. Angle-Type Strainers:
1. Body: Forged brass or cast bronze.
 2. Drain Plug: Brass hex plug.
 3. Screen: 100-mesh monel.
 4. End Connections: Socket or flare.
 5. Working Pressure Rating: 500 psig
 6. Maximum Operating Temperature: 275 deg F
- I. Moisture/Liquid Indicators:
1. Body: Forged brass.
 2. Window: Replaceable, clear, fused glass window with indicating element protected by filter screen.
 3. Indicator: Color coded to show moisture content in ppm.
 4. Minimum Moisture Indicator Sensitivity: Indicate moisture above 60 ppm.
 5. End Connections: Socket or flare.
 6. Working Pressure Rating: 500 psig
 7. Maximum Operating Temperature: 240 deg F

- J. Replaceable-Core Filter Dryers: Comply with ARI 730.
 - 1. Body and Cover: Painted-steel shell with ductile-iron cover, stainless-steel screws, and neoprene gaskets.
 - 2. Filter Media: 10 micron, pleated with integral end rings; stainless-steel support.
 - 3. Desiccant Media: Activated alumina
 - 4. End Connections: Socket.
 - 5. Access Ports: NPS 1/4 connections at entering and leaving sides for pressure differential measurement.
 - 6. Maximum Pressure Loss: 2 psig
 - 7. Working Pressure Rating: 500 psig
 - 8. Maximum Operating Temperature: 240 deg F

2.3 REFRIGERANTS

- A. R-410A:

PART 3 - EXECUTION

3.1 PIPING APPLICATIONS

- A. Suction Lines NPS 1-5/8 and Smaller for Conventional Air-Conditioning Applications: Copper, Type L drawn-temper tubing and wrought-copper fittings with brazed joints.
- B. Hot-Gas and Liquid Lines: Copper, Type L drawn-temper tubing and wrought-copper fittings with brazed joints.

3.2 VALVE AND SPECIALTY APPLICATIONS

- A. Install diaphragm packless valves in suction and discharge lines of compressor.
- B. Install service valves for gage taps at strainers if they are not an integral part of strainers.
- C. Install a check valve at the compressor discharge and at the compressor suction connection.
- D. Except as otherwise indicated, install diaphragm packless valves on inlet and outlet side of filter dryers.
- E. Install a full-sized, three-valve bypass around filter dryers.
- F. Install solenoid valves upstream from each expansion valve. Install solenoid valves in horizontal lines with coil at top.
- G. Install thermostatic expansion valves as close as possible to distributors on evaporators.
 - 1. Install valve so diaphragm case is warmer than bulb.
 - 2. Secure bulb to clean, straight, horizontal section of suction line using two bulb straps. Do not mount bulb in a trap or at bottom of the line.
 - 3. If external equalizer lines are required, make connection where it will reflect suction-line pressure at bulb location.
- H. Install safety relief valves where required by ASME Boiler and Pressure Vessel Code. Pipe safety-relief-valve discharge line to outside according to ASHRAE 15.

- I. Install moisture/liquid indicators in liquid line at the inlet of the thermostatic expansion valve or at the inlet of the evaporator coil capillary tube.
- J. Install strainers upstream from and adjacent to the following unless they are furnished as an integral assembly for device being protected:
 - 1. Solenoid valves.
 - 2. Thermostatic expansion valves.
 - 3. Compressor.
- K. Install filter dryers in liquid line between compressor and thermostatic expansion valve.
- L. Install flexible connectors at compressors.

3.3 PIPING INSTALLATION

- A. Drawing plans, schematics, and diagrams indicate general location and arrangement of piping systems; indicated locations and arrangements were used to size pipe and calculate friction loss, expansion, pump sizing, and other design considerations. Install piping as indicated unless deviations to layout are approved on Shop Drawings.
- B. Install VRF Heat Pump refrigerant piping in accordance with manufacturers written instructions. Include solenoid valve controllers and refrigeration box controller.
- C. Install refrigerant piping according to ASHRAE 15.
- D. Install piping in concealed locations unless otherwise indicated and except in equipment rooms and service areas.
- E. Install piping indicated in areas at right angles or parallel to building walls. Diagonal runs are prohibited unless specifically indicated otherwise.
- F. Install piping above accessible ceilings to allow sufficient space for ceiling panel removal.
- G. Install VRF heat pump box controller and solenoid valve controllers above accessible ceiling to allow for service access.
- H. Install piping adjacent to machines to allow service and maintenance.
- I. Install piping free of sags and bends.
- J. Install fittings for changes in direction and branch connections.
- K. Select system components with pressure rating equal to or greater than system operating pressure.
- L. Refer to Division 23 Sections "Instrumentation and Control for HVAC" and "Sequence of Operations for HVAC Controls" for solenoid valve controllers, control wiring, and sequence of operation.
- M. Install piping as short and direct as possible, with a minimum number of joints, elbows, and fittings.
- N. Arrange piping to allow inspection and service of refrigeration equipment. Install valves and specialties in accessible locations to allow for service and inspection. Install access doors or

panels as specified in Division 08 Section "Access Doors and Frames" if valves or equipment requiring maintenance is concealed behind finished surfaces.

- O. Slope refrigerant piping as follows:
 1. Install horizontal hot-gas discharge piping with a uniform slope downward away from compressor.
 2. Install horizontal suction lines with a uniform slope downward to compressor.
 3. Install traps and double risers to entrain oil in vertical runs.
 4. Liquid lines may be installed level.
- P. When brazing remove solenoid-valve coils and sight glasses; also remove valve stems, seats, and packing, and accessible internal parts of refrigerant specialties. Do not apply heat near expansion-valve bulb.
- Q. Install pipe sleeves at penetrations in exterior walls, roof and floor assemblies.
- R. Seal penetrations through fire and smoke barriers according to Division 07 Section "Penetration Firestopping."
- S. Install piping with adequate clearance between pipe and adjacent walls and hangers or between pipes for insulation installation.
- T. Install sleeves through floors, walls, or ceilings, sized to permit installation of full-thickness insulation.
- U. Seal pipe penetrations through exterior walls according to Division 07 Section "Joint Sealants" for materials and methods.
- V. Identify refrigerant piping and valves according to Division 23 Section "Identification for HVAC Piping and Equipment."

3.4 PIPE JOINT CONSTRUCTION

- A. Brazed Joints: Construct joints according to AWS's "Brazing Handbook," Chapter "Pipe and Tube."
 1. Use Type BcuP, copper-phosphorus alloy for joining copper socket fittings with copper pipe.

3.5 HANGERS AND SUPPORTS

- A. Hanger, support, and anchor products are specified in Division 23 Section "Hangers and Supports for HVAC Piping and Equipment."
- B. Install the following pipe attachments:
 1. Adjustable steel clevis hangers for individual horizontal runs less than 20 feet long.
 2. Copper-clad hangers and supports for hangers and supports in direct contact with copper pipe.
- C. Install hangers for copper tubing with the following maximum spacing and minimum rod sizes:
 1. NPS 1/2 Maximum span, 60 minimum rod size, 1/4 inch
 2. NPS 5/8 Maximum span, 60 inches minimum rod size, 1/4 inch
 3. NPS 1 Maximum span, 72 inches minimum rod size, 1/4 inch
 4. NPS 1-1/4 Maximum span, 96 inches minimum rod size, 3/8 inch
 5. NPS 1-1/2 Maximum span, 96 inches minimum rod size, 3/8 inch (

- D. Support multifloor vertical runs at least at each floor.

3.6 FIELD QUALITY CONTROL

- A. Perform tests and inspections and prepare test reports.
- B. Tests and Inspections:
 - 1. Comply with ASME B31.5, Chapter VI.
 - 2. Test refrigerant piping and specialties. Isolate compressor, condenser, evaporator, and safety devices from test pressure if they are not rated above the test pressure.
 - 3. Test high- and low-pressure side piping of each system separately at not less than the pressures indicated in Part 1 "Performance Requirements" Article.
 - a. Fill system with nitrogen to the required test pressure.
 - b. System shall maintain test pressure at the manifold gage throughout duration of test.
 - c. Test joints and fittings with electronic leak detector or by brushing a small amount of soap and glycerin solution over joints.
 - d. Remake leaking joints using new materials, and retest until satisfactory results are achieved.

3.7 SYSTEM CHARGING

- A. Charge system using the following procedures:
 - 1. Install core in filter dryers after leak test but before evacuation.
 - 2. Charge system with a new filter-dryer core in charging line and with new refrigerant.

3.8 ADJUSTING

- A. Adjust thermostatic expansion valve to obtain proper evaporator superheat.
- B. Adjust high- and low-pressure switch settings to avoid short cycling in response to fluctuating suction pressure.
- C. Adjust set-point temperature of air-conditioning or chilled-water controllers to the system design temperature.
- D. Perform the following adjustments before operating the refrigeration system, according to manufacturer's written instructions:
 - 1. Open shutoff valves in condenser water circuit.
 - 2. Verify that compressor oil level is correct.
 - 3. Open compressor suction and discharge valves.
 - 4. Open refrigerant valves except bypass valves that are used for other purposes.
 - 5. Check open compressor-motor alignment and verify lubrication for motors and bearings.
- E. Replace core of replaceable filter dryer after system has been adjusted and after design flow rates and pressures are established.

END OF SECTION 23 2300

SECTION 23 3113 - METAL DUCTS**PART 1 - GENERAL****1.1 SUMMARY**

- A. Section Includes:
 - 1. Rectangular ducts and fittings.
 - 2. Round ducts and fittings.
 - 3. Sheet metal materials.
 - 4. Sealants and gaskets.
 - 5. Hangers and supports.
 - 6. Seismic-restraint devices.
- B. Related Sections:
 - 1. Division 23 Section "Testing, Adjusting, and Balancing for HVAC" for testing, adjusting, and balancing requirements for metal ducts.
 - 2. Division 23 Section "Air Duct Accessories" for dampers, sound-control devices, duct-mounting access doors and panels, turning vanes, and flexible ducts.

1.2 PERFORMANCE REQUIREMENTS

- A. Delegated Duct Design: Duct construction, including sheet metal thicknesses, seam and joint construction, reinforcements, and hangers and supports, shall comply with SMACNA's "HVAC Duct Construction Standards - Metal and Flexible" and performance requirements and design criteria indicated in "Duct Schedule" Article.
- B. Structural Performance: Duct hangers and supports and seismic restraints shall withstand the effects of gravity and seismic loads and stresses within limits and under conditions described in SMACNA's "HVAC Duct Construction Standards
- C. Airstream Surfaces: Surfaces in contact with the airstream shall comply with requirements in ASHRAE 62.1-2004.

1.3 SUBMITTALS

- A. Product Data: For each type of product indicated.
- B. Welding certificates.

1.4 QUALITY ASSURANCE

- A. Welding Qualifications: Qualify procedures and personnel according to the following:
 - 1. AWS D1.1/D1.1M, "Structural Welding Code - Steel," for hangers and supports.

PART 2 - PRODUCTS**2.1 RECTANGULAR DUCTS AND FITTINGS**

- A. General Fabrication Requirements: Comply with SMACNA's "HVAC Duct Construction Standards - Metal and Flexible" based on indicated static-pressure class unless otherwise indicated.
- B. Transverse Joints: Select joint types and fabricate according to SMACNA's "HVAC Duct Construction Standards - Metal and Flexible," Figure 1-4, "Transverse (Girth) Joints," for static-

pressure class, applicable sealing requirements, materials involved, duct-support intervals, and other provisions in SMACNA's "HVAC Duct Construction Standards - Metal and Flexible."

- C. Longitudinal Seams: Select seam types and fabricate according to SMACNA's "HVAC Duct Construction Standards - Metal and Flexible," Figure 1-5, "Longitudinal Seams - Rectangular Ducts," for static-pressure class, applicable sealing requirements, materials involved, duct-support intervals, and other provisions in SMACNA's "HVAC Duct Construction Standards - Metal and Flexible."
- D. Elbows, Transitions, Offsets, Branch Connections, and Other Duct Construction: Select types and fabricate according to SMACNA's "HVAC Duct Construction Standards - Metal and Flexible," Chapter 2, "Fittings and Other Construction," for static-pressure class, applicable sealing requirements, materials involved, duct-support intervals, and other provisions in SMACNA's "HVAC Duct Construction Standards - Metal and Flexible."

2.2 ROUND DUCTS AND FITTINGS

- A. General Fabrication Requirements: Comply with SMACNA's "HVAC Duct Construction Standards - Metal and Flexible," Chapter 3, "Round, Oval, and Flexible Duct," based on indicated static-pressure class unless otherwise indicated.
- B. Transverse Joints: Select joint types and fabricate according to SMACNA's "HVAC Duct Construction Standards - Metal and Flexible," Figure 3-2, "Transverse Joints - Round Duct," for static-pressure class, applicable sealing requirements, materials involved, duct-support intervals, and other provisions in SMACNA's "HVAC Duct Construction Standards - Metal and Flexible."
- C. Longitudinal Seams: Select seam types and fabricate according to SMACNA's "HVAC Duct Construction Standards - Metal and Flexible," Figure 3-1, "Seams - Round Duct and Fittings," for static-pressure class, applicable sealing requirements, materials involved, duct-support intervals, and other provisions in SMACNA's "HVAC Duct Construction Standards - Metal and Flexible."
- D. Tees and Laterals: Select types and fabricate according to SMACNA's "HVAC Duct Construction Standards - Metal and Flexible," Figure 3-4, "90 Degree Tees and Laterals," and Figure 3-5, "Conical Tees," for static-pressure class, applicable sealing requirements, materials involved, duct-support intervals, and other provisions in SMACNA's "HVAC Duct Construction Standards - Metal and Flexible."

2.3 SHEET METAL MATERIALS

- A. General Material Requirements: Comply with SMACNA's "HVAC Duct Construction Standards - Metal and Flexible" for acceptable materials, material thicknesses, and duct construction methods unless otherwise indicated. Sheet metal materials shall be free of pitting, seam marks, roller marks, stains, discolorations, and other imperfections.
- B. Galvanized Sheet Steel: Comply with ASTM A 653/A 653M.
 - 1. Galvanized Coating Designation: G60
 - 2. Finishes for Surfaces Exposed to View: Mill phosphatized.
- C. Reinforcement Shapes and Plates: ASTM A 36/A 36M, steel plates, shapes, and bars; black and galvanized.
 - 1. Where black- and galvanized-steel shapes and plates are used to reinforce aluminum ducts, isolate the different metals with butyl rubber, neoprene, or EPDM gasket materials.

2.4 STAINLESS STEEL DUCT MATERIALS

- A. All exhaust ducts serving dishwasher hood shall be constructed of 304 stainless steel with welded joints and seams.

2.5 GREASE DUCT MATERIALS

- A. All exhaust ducts serving kitchen cooking hoods shall be constructed of double wall 18 gauge stainless steel grease duct rated and labeled for grease duct applications. Grease duct shall be double wall with insulation barrier for zero clearance to combustible rating. Grease duct shall be round and suitable for both exterior and interior use. Interior grease duct shall be fire wrapped in accordance with the specifications.
- B. A light test shall be performed to determine that all welded joints are liquid tight. A light test shall be performed by passing a lamp having a power rating of not less than 100 watts through the entire section of duct work to be tested. The lamp shall be open so as to emit light equally in all directions perpendicular to the duct walls with no light evident.

2.6 SEALANTS

- A. General Sealant and Gasket Requirements: Surface-burning characteristics for sealants and gaskets shall be a maximum flame-spread index of 25 and a maximum smoke-developed index of 50 when tested according to UL 723; certified by an NRTL.
- B. Water-Based Joint and Seam Sealant:
 - 1. Application Method: Brush on.
 - 2. Solids Content: Minimum 65 percent.
 - 3. Shore A Hardness: Minimum 20.
 - 4. Water resistant.
 - 5. Mold and mildew resistant.
 - 6. VOC: Maximum 75 g/L (less water).
 - 7. Maximum Static-Pressure Class: 10-inch wg positive and negative.
 - 8. Service: Indoor or outdoor.
 - 9. Substrate: Compatible with galvanized sheet steel (both PVC coated and bare), stainless steel, or aluminum sheets.

2.7 HANGERS AND SUPPORTS

- A. Hanger Rods for Noncorrosive Environments: Cadmium-plated steel rods and nuts.
- B. Hanger Rods for Corrosive Environments: Electrogalvanized, all-thread rods or galvanized rods with threads painted with zinc-chromate primer after installation.
- C. Strap and Rod Sizes: Comply with SMACNA's "HVAC Duct Construction Standards - Metal and Flexible," Table 4-1 "Rectangular Duct Hangers Minimum Size," and Table 4-2, "Minimum Hanger Sizes for Round Duct."
- D. Steel Cables for Galvanized-Steel Ducts: Galvanized steel complying with ASTM A 603.
- E. Steel Cable End Connections: Cadmium-plated steel assemblies with brackets, swivel, and bolts designed for duct hanger service; with an automatic-locking and clamping device.
- F. Duct Attachments: Sheet metal screws, blind rivets, or self-tapping metal screws; compatible with duct materials..

2.8 SEISMIC-RESTRAINT DEVICES

- A. General Requirements for Restraint Components: Rated strengths, features, and applications shall be as defined in reports
- B. Restraint Cables: ASTM A 603, galvanized-steel cables with end connections made of cadmium-plated steel assemblies with brackets, swivel, and bolts designed for restraining cable service; and with an automatic-locking and clamping device or double-cable clips.

PART 3 - EXECUTION

3.1 DUCT INSTALLATION

- A. Drawing plans, schematics, and diagrams indicate general location and arrangement of duct system. Indicated duct locations, configurations, and arrangements were used to size ducts and calculate friction loss for air-handling equipment sizing and for other design considerations. Install duct systems as indicated unless deviations to layout are approved on Shop Drawings and Coordination Drawings.
- B. Install ducts according to SMACNA's "HVAC Duct Construction Standards - Metal and Flexible" unless otherwise indicated.
- C. Install round ducts in maximum practical lengths.
- D. Install ducts with fewest possible joints.
- E. Install factory- or shop-fabricated fittings for changes in direction, size, and shape and for branch connections.
- F. Unless otherwise indicated, install ducts vertically and horizontally, and parallel and perpendicular to building lines.
- G. Install ducts close to walls, overhead construction, columns, and other structural and permanent enclosure elements of building.
- H. Install ducts with a clearance of 1 inch plus allowance for insulation thickness.
- I. Route ducts to avoid passing through transformer vaults and electrical equipment rooms and enclosures.
- J. Where ducts pass through non-fire-rated interior partitions and exterior walls and are exposed to view, cover the opening between the partition and duct or duct insulation with sheet metal flanges of same metal thickness as the duct. Overlap openings on four sides by at least 1-1/2 inches
- K. Protect duct interiors from moisture, construction debris and dust, and other foreign materials. Comply with SMACNA's "Duct Cleanliness for New Construction Guidelines."

3.2 DUCT SEALING

- A. Seal ducts for duct static-pressure, seal classes, and leakage classes specified in "Duct Schedule" Article according to SMACNA's "HVAC Duct Construction Standards - Metal and Flexible."
- B. Seal ducts to the following seal classes according to SMACNA's "HVAC Duct Construction Standards - Metal and Flexible":

1. Comply with SMACNA's "HVAC Duct Construction Standards - Metal and Flexible."
2. Unconditioned Space, Supply-Air Ducts in Pressure Classes 2-Inch wg (500 Pa) and Lower: Seal Class B.
3. Unconditioned Space, Supply-Air Ducts in Pressure Classes Higher Than 2-Inch wg (500 Pa): Seal Class A.
4. Unconditioned Space, Exhaust Ducts: Seal Class C.
5. Unconditioned Space, Return-Air Ducts: Seal Class B.

3.3 HANGER AND SUPPORT INSTALLATION

- A. Comply with SMACNA's "HVAC Duct Construction Standards - Metal and Flexible," Chapter 4, "Hangers and Supports."
- B. Building Attachments: Concrete inserts, powder-actuated fasteners, or structural-steel fasteners appropriate for construction materials to which hangers are being attached.
- C. Hanger Spacing: Comply with SMACNA's "HVAC Duct Construction Standards - Metal and Flexible," Table 4-1 .
- D. Hangers Exposed to View: Threaded rod and angle or channel supports.
- E. Support vertical ducts with steel angles or channel secured to the sides of the duct with welds, bolts, sheet metal screws, or blind rivets; support at each floor and at a maximum intervals of 16 feet
- F. Install upper attachments to structures. Select and size upper attachments with pull-out, tension, and shear capacities appropriate for supported loads and building materials where used.

3.4 SEISMIC-RESTRAINT-DEVICE INSTALLATION

- A. Install ducts with hangers and braces designed to support the duct and to restrain against seismic forces required by applicable building codes. Comply with SMACNA's "Seismic Restraint Manual: Guidelines for Mechanical Systems." and ASCE/SEI 7..

3.5 CONNECTIONS

- A. Make connections to equipment with flexible connectors complying with Division 23 Section "Air Duct Accessories."
- B. Comply with SMACNA's "HVAC Duct Construction Standards - Metal and Flexible" for branch, outlet and inlet, and terminal unit connections.

3.6 DUCT CLEANING

- A. Clean new duct system(s) before testing, adjusting, and balancing.
 1. .

3.7 START UP

- A. Air Balance: Comply with requirements in Division 23 Section "Testing, Adjusting, and Balancing for HVAC."

3.8 DUCT SCHEDULE

- A. Fabricate ducts with galvanized sheet steel except as otherwise indicated and as follows:

- B. Supply Ducts:
 - 1. Ducts Connected to Constant-Volume Air-Handling Units
 - a. Pressure Class: Positive 2-inch wg
 - b. Minimum SMACNA Seal Class: A

- C. Exhaust Ducts:
 - 1. Ducts Connected to Fans Exhausting Air:
 - a. Pressure Class: Negative 1-inch wg
 - b. Minimum SMACNA Seal Class: A and A if positive pressure.

- D. Branch Configuration:
 - 1. Rectangular Duct: Comply with SMACNA's "HVAC Duct Construction Standards - Metal and Flexible," Figure 2-6, "Branch Connections."
 - a. Rectangular Main to Rectangular Branch: 45-degree entry.
 - b. Rectangular Main to Round Branch: Spin in.
 - 2. Round: Comply with SMACNA's "HVAC Duct Construction Standards - Metal and Flexible," Figure 3-4, "90 Degree Tees and Laterals," and Figure 3-5, "Conical Tees." Saddle taps are permitted in existing duct.

END OF SECTION 23 3113

SECTION 23 3300 - AIR DUCT ACCESSORIES**PART 1 - GENERAL****1.1 SUMMARY**

- A. Section Includes:
 - 1. Backdraft and pressure relief dampers.
 - 2. Manual volume dampers.
 - 3. Flange connectors.
 - 4. Turning vanes.

1.2 SUBMITTALS

- A. Product Data: For each type of product indicated.
- B. Operation and maintenance data.

1.3 QUALITY ASSURANCE

- A. Comply with NFPA 90A, "Installation of Air Conditioning and Ventilating Systems," and with NFPA 90B, "Installation of Warm Air Heating and Air Conditioning Systems."
- B. Comply with AMCA 500-D testing for damper rating.

PART 2 - PRODUCTS**2.1 MATERIALS**

- A. Comply with SMACNA's "HVAC Duct Construction Standards - Metal and Flexible" for acceptable materials, material thicknesses, and duct construction methods unless otherwise indicated. Sheet metal materials shall be free of pitting, seam marks, roller marks, stains, discolorations, and other imperfections.
- B. Galvanized Sheet Steel: Comply with ASTM A 653/A 653M.
 - 1. Galvanized Coating Designation: G60
 - 2. Exposed-Surface Finish: Mill phosphatized.
- C. Reinforcement Shapes and Plates: Galvanized-steel reinforcement where installed on galvanized sheet metal ducts; compatible materials for aluminum and stainless-steel ducts.

2.2 BACKDRAFT AND PRESSURE RELIEF DAMPERS

- A. Description: Gravity balanced.
- B. Maximum Air Velocity: 2000 fpm
- C. Maximum System Pressure: 1-inch wg
- D. Frame: 0.052-inch- thick, galvanized sheet steel and mounting flange.
- E. Blades: Multiple single-piece blades, center-pivoted,] maximum 6-inch width with sealed edges.
- F. Blade Action: Parallel.

- G. Blade Seals: Vinyl foam
- H. Blade Axles:
 - 1. Material: Nonferrous metal

2.3 MANUAL VOLUME DAMPERS

- A. Standard, Steel, Manual Volume Dampers:
 - 1. Manufacturers: Subject to compliance with requirements, provide products by one of the following
 - a. Air Balance Inc.; a division of Mestek, Inc.
 - b. American Warming and Ventilating; a division of Mestek, Inc.
 - c. Flexmaster U.S.A., Inc.
 - d. METALAIR, Inc.
 - e. Nailor Industries Inc.
 - f. Pottorff; a division of PCI Industries, Inc.
 - g. Ruskin Company.
 - 2. Standard leakage rating
 - 3. Suitable for horizontal or vertical applications.
 - 4. Frames:
 - a. Hat-shaped, galvanized channels, 0.064-inch minimum thickness.
 - b. Mitered and welded corners.
 - c. Flanges for attaching to walls and flangeless frames for installing in ducts.
 - 5. Blades:
 - a. Multiple or single blade.
 - b. Parallel- or opposed-blade design.
 - c. Stiffen damper blades for stability.
 - 6. Blade Axles: Galvanized steel
 - 7. Bearings:
 - a. Oil-impregnated bronze
 - b. Dampers in ducts with pressure classes of 3-inch wg or less shall have axles full length of damper blades and bearings at both ends of operating shaft.
- B. Damper Hardware:
 - 1. Zinc-plated, die-cast core with dial and handle made of 3/32-inch- thick zinc-plated steel, and a 3/4-inch hexagon locking nut.
 - 2. Include center hole to suit damper operating-rod size.
 - 3. Include elevated platform for insulated duct mounting.

2.4 FLANGE CONNECTORS

- A. Manufacturers: Subject to compliance with requirements, provide products by one of the following
 - 1. Ductmate Industries, Inc.
 - 2. Nexus PDQ; Division of Shilco Holdings Inc.
 - 3. Ward Industries, Inc.; a division of Hart & Cooley, Inc.
- B. Description: Factory-fabricated, slide-on transverse flange connectors, gaskets, and components.
- C. Material: Galvanized steel.
- D. Gage and Shape: Match connecting ductwork.

2.5 TURNING VANES

- A. Manufactured Turning Vanes for Metal Ducts: Curved blades of galvanized sheet steel; support with bars perpendicular to blades set; set into vane runners suitable for duct mounting.
 - 1. Acoustic Turning Vanes: Fabricate airfoil-shaped aluminum extrusions with perforated faces and fibrous-glass fill.
- B. General Requirements: Comply with SMACNA's "HVAC Duct Construction Standards - Metal and Flexible"; Figures 2-3, "Vanes and Vane Runners," and 2-4, "Vane Support in Elbows."
- C. Vane Construction: Single wall.

2.6 DUCT ACCESSORY HARDWARE

- A. Instrument Test Holes: Cast iron or cast aluminum to suit duct material, including screw cap and gasket. Size to allow insertion of pitot tube and other testing instruments and of length to suit duct-insulation thickness.
- B. Adhesives: High strength, quick setting, neoprene based, waterproof, and resistant to gasoline and grease.

PART 3 - EXECUTION

3.1 INSTALLATION

- A. Install duct accessories according to applicable details in SMACNA's "HVAC Duct Construction Standards - Metal and Flexible" for metal ducts and in NAIMA AH116, "Fibrous Glass Duct Construction Standards," for fibrous-glass ducts.
- B. Install duct accessories of materials suited to duct materials; use galvanized-steel accessories in galvanized-steel and fibrous-glass ducts, stainless-steel accessories in stainless-steel ducts, and aluminum accessories in aluminum ducts.
- C. Install volume dampers at points on supply and exhaust systems where branches extend from larger ducts.
 - 1. Install steel volume dampers in steel ducts.
 - 2. Install aluminum volume dampers in aluminum ducts.
- D. Set dampers to fully open position before testing, adjusting, and balancing.
- E. Connect diffusers to ducts with maximum 60-inch lengths of flexible duct clamped or strapped in place.
- F. Connect flexible ducts to metal ducts with dual draw bands.
- G. Install duct test holes where required for testing and balancing purposes.

3.2 FIELD QUALITY CONTROL

- A. Tests and Inspections:
 - 1. Operate dampers to verify full range of movement.
 - 2. Inspect locations of access doors and verify that purpose of access door can be performed.
 - 3. Inspect turning vanes for proper and secure installation.

END OF SECTION 23 3300

SECTION 23 3423 - HVAC POWER VENTILATORS**PART 1 - GENERAL****1.1 SUMMARY**

- A. This Section includes the following:
 - 1. Utility set fans
 - 2. Centrifugal roof ventilators.
 - 3. Ceiling Exhaust Fans

1.2 SUBMITTALS

- A. Product Data: Include rated capacities, furnished specialties, and accessories for each type of product indicated and include the following:
- B. Operation and maintenance data.

1.3 QUALITY ASSURANCE

- A. Electrical Components, Devices, and Accessories: Listed and labeled as defined in NFPA 70, Article 100, by a testing agency acceptable to authorities having jurisdiction, and marked for intended use.
- B. NEMA Compliance: Motors and electrical accessories shall comply with NEMA standards.
- C. UL Standard: Power ventilators shall comply with UL 705.
- D. Manufacturers: Subject to compliance with requirements, provide products by one of the following:
 - 1. Breidert Air Products.
 - 2. Broan Mfg. Co., Inc.
 - 3. Carnes Company HVAC.
 - 4. Loren Cook Company.
 - 5. Penn Ventilation.

E.

PART 2 - PRODUCTS**2.1 UTILITY SET FANS**

- A. Description: Belt driven, heavy gauge steel utility set fan, rotated to vertical discharge position. Consisting of heavy gauge steel housing, fan wheel, fan shaft, bearings, motor, weather proof cover, factory disconnect switch, drive assembly, and accessories.
- B. Configured and labeled for high temperature grease exhaust serving kitchen hood complete with grease tube and grease trough.
- C. Fan Wheels: Heavy gauge black steel with backward-inclined blades.
- D. Belt-Driven Drive Assembly: Resiliently mounted to housing, with the following features:
 - 1. Fan Shaft: Turned, ground, and polished steel; keyed to wheel hub.
 - 2. Shaft Bearings: Permanently lubricated, permanently sealed, self-aligning ball bearings.
 - 3. Pulleys: Cast-iron, adjustable-pitch motor pulley.

4. Fan and motor isolated from exhaust airstream.

E. Accessories:

1. Disconnect Switch: Nonfusible type, with thermal-overload protection mounted inside fan housing, factory wired through an internal aluminum conduit.
2. Grease tube with grease trough for collecting grease waste inside the fan scroll

- F. Roof Curbs: Galvanized steel; mitered and welded corners with plywood deck and covered in stainless steel cladding. Size as specified but no less than 14 inches high.

2.2 CENTRIFUGAL ROOF VENTILATORS

- A. Description: Belt driven centrifugal fans consisting of housing, wheel, fan shaft, bearings, motor and disconnect switch, drive assembly, 18 inch high curb base, and accessories.

- B. Housing: Removable, spun-aluminum, dome top and outlet baffle square, one-piece, aluminum base with venturi inlet cone.

- C. Fan Wheels: Aluminum hub and wheel with backward-inclined blades.

- D. Belt-Driven Drive Assembly: Resiliently mounted to housing, with the following features:

1. Fan Shaft: Turned, ground, and polished steel; keyed to wheel hub.
2. Shaft Bearings: Permanently lubricated, permanently sealed, self-aligning ball bearings.
3. Pulleys: Cast-iron, adjustable-pitch motor pulley.
4. Fan and motor isolated from exhaust airstream.

E. Accessories:

1. Disconnect Switch: Nonfusible type, with thermal-overload protection mounted inside fan housing, factory wired through an internal aluminum conduit.
2. Bird Screens: Removable, 1/2-inch mesh, aluminum or brass wire.
3. Dampers: Motorized, parallel-blade, backdraft dampers mounted in curb base; ATC controlled to open when fan starts and to close when fan stops.

- F. Roof Curbs: Galvanized steel; mitered and welded corners; 1-1/2-inch- thick, rigid, fiberglass insulation adhered to inside walls; and 1-1/2-inch wood nailer. Size as specified but no less than 14 inches high.

1. Configuration: Self-flashing without a cant strip, with mounting flange
2. Overall Height: 14 inches
3. Sound Curb: Curb with sound-absorbing insulation matrix.
4. Pitch Mounting: Manufacture curb for roof slope.
5. Metal Liner: Galvanized steel.

2.3 CEILING-MOUNTING VENTILATORS

- A. Manufacturers: Subject to compliance with requirements, provide products by one of the following:

1. Breidert Air Products.
2. Broan Mfg. Co., Inc.
3. Loren Cook Company.
4. Penn Ventilation.

- B. Description: Centrifugal fans designed for installing in ceiling.

- C. Housing: Steel, lined with acoustical insulation.

- D. Fan Wheel: Centrifugal wheels directly mounted on motor shaft. Fan shrouds, motor, and fan wheel shall be removable for service.

- E. Grille: Painted aluminum, louvered grille with flange on intake and thumbscrew attachment to fan housing.
- F. Electrical Requirements: Junction box for electrical connection on housing and receptacle for motor plug-in.

PART 3 - EXECUTION

3.1 INSTALLATION

- A. Install power ventilators level and plumb.
- B. Support units using elastomeric mounts
- C. Secure roof-mounting fans to roof curbs with cadmium-plated hardware.
- D. Install units with clearances for service and maintenance.
- E. Label units according to requirements specified in Division 23 Section "Identification for HVAC Piping and Equipment."
- F. Duct installation and connection requirements are specified in other Division 23 Sections. Drawings indicate general arrangement of ducts and duct accessories. Make final duct connections with flexible connectors. Flexible connectors are specified in Division 23 Section "Air Duct Accessories."
- G. Install ducts adjacent to power ventilators to allow service and maintenance.

3.2 FIELD QUALITY CONTROL

- A. Perform the following field tests and inspections and prepare test reports:
 - 1. Verify that shipping, blocking, and bracing are removed.
 - 2. Verify that unit is secure on mountings and supporting devices and that connections to ducts and electrical components are complete. Verify that proper thermal-overload protection is installed in motors, starters, and disconnect switches.
 - 3. Verify that cleaning and adjusting are complete.
 - 4. Disconnect fan drive from motor, verify proper motor rotation direction, and verify fan wheel free rotation and smooth bearing operation. Reconnect fan drive system, align and adjust belts, and install belt guards.
 - 5. Adjust belt tension.
 - 6. Adjust damper linkages for proper damper operation.
 - 7. Verify lubrication for bearings and other moving parts.
 - 8. Verify that manual and automatic volume control and fire and smoke dampers in connected ductwork systems are in fully open position.
 - 9. Disable automatic temperature-control operators, energize motor and adjust fan to indicated rpm, and measure and record motor voltage and amperage.
 - 10. Shut unit down and reconnect automatic temperature-control operators.
 - 11. Remove and replace malfunctioning units and retest as specified above.
- B. Test and adjust controls and safeties. Replace damaged and malfunctioning controls and equipment.

END OF SECTION 23 3423

SECTION 23 7433 - PACKAGED, OUTDOOR, MAKEUP AIR-UNITS

PART 1 - GENERAL

1.1 SUMMARY

- A. This Section includes gas fired heating and evaporative cooling make up air units.

1.2 SUBMITTALS

- A. Product Data: Include rated capacities, furnished specialties, and accessories.
- B. Shop Drawings: Include details of installation and wiring diagrams.
- C. Coordination Drawings: Rooftop replacement-air units to roof-curb mounting details drawn to scale, on which the following items are shown and coordinated with each other, based on input from installers of the items involved:
 - 1. Size and location of rooftop replacement-air unit mounting rails and anchor points and methods for anchoring units to roof curb.
 - 2. Required roof penetrations for ducts, pipes, and electrical raceways, including size and location of each penetration.
- D. Startup service reports.
- E. Operation and maintenance data.
- F. Warranty.

1.3 QUALITY ASSURANCE

- A. Electrical Components, Devices, and Accessories: Listed and labeled as defined in NFPA 70, Article 100, by a testing agency acceptable to authorities having jurisdiction, and marked for intended use.
- B. ASHRAE Compliance: Applicable requirements in ASHRAE 62.1-2015, Section 5 - "Systems and Equipment" and Section 7 - "Construction and Startup."
- C. ASHRAE/IESNA 90.1-2004 Compliance: Applicable requirements in ASHRAE/IESNA 90.1-2015, Section 6 - "Heating, Ventilating, and Air-Conditioning."

1.4 WARRANTY

- A. Warranty: Manufacturer's standard form in which manufacturer agrees to replace components that fail within 1 year from date of Substantial Completion.

PART 2 - PRODUCTS

2.1 MANUFACTURERS

- A. Manufacturers: Subject to compliance with requirements, provide products by one of the following:
1. AAON, Inc.
 2. Captive Aire
 3. Econ Air
 4. Reznor

2.2 CABINET

- A. Construction: Single wall insulated.
- B. Exterior Casing: Galvanized steel with powder coated paint finish with lifting lugs and knockouts for electrical and piping connections.
- C. Interior Casing: Galvanized and Stainless steel. Stainless for evaporative cooler section.
- D. Base Rails: Galvanized steel rails for mounting on roof curb.
- E. Service Doors: Hinged access doors with locking quadrant handles and neoprene gaskets.
- F. Internal Insulation: Fibrous-glass duct lining complying with ASTM C 1071, Type II.
1. Thickness: 1 inch
 2. Insulation Adhesive: Comply with ASTM C 916, Type I.
 3. Mechanical Fasteners: Galvanized steel, suitable for adhesive attachment, mechanical attachment, or welding attachment to casing without damaging liner and without causing air leakage when applied as recommended by manufacturer.
- G. Condensate Drain Pans: Formed sections of stainless-steel sheet designed for self-drainage. Fabricate pans and drain connection to comply with ASHRAE 62.1-2015.
- H. Roof Curb: Full-perimeter curb of sheet metal, minimum 14 inches high, with wood nailer, neoprene sealing strip, and welded Z-bar flashing.
- I. Airstream Surfaces: Surfaces in contact with the airstream shall comply with requirements in ASHRAE 62.1-2015.

2.3 SUPPLY-AIR FAN

- A. Fan: Forward-curved centrifugal; statically and dynamically balanced, galvanized steel, mounted on solid-steel shaft with self-aligning, permanently lubricated ball bearings.
- B. Motor: Totally enclosed two-speed motor.
- C. Drive: V-belt drive with matching fan pulley and adjustable motor sheaves and belt assembly with minimum 1.4 service factor.

- D. Mounting: Fan wheel, motor, and drives shall be mounted in fan casing with spring isolators.

2.4 EVAPORATIVE COOLING SYSTEM

- A. Fabricate evaporative cooling section using stainless steel panels and post and beam construction for corrosion protection.
- B. Water cooled cooling section consisting of 12 inch thick Celdek evaporative media complete with water wash or spray pump, stainless steel sump, water level controller, water spray distribution system, stainless steel drain pan and drain plug.

2.5 INDIRECT-FIRED GAS FURNACE

- A. Description: Factory assembled, piped, and wired; complying with NFPA 54, "National Fuel Gas Code," and ANSI Z21.47, "Gas-Fired Central Furnaces."
 - 1. AGA Approval: Designed and certified by and bearing label of AGA.
- B. Burners: Stainless-steel
 - 1. Minimum AFUE: 81 percent.
 - 2. Fuel: Natural gas.
 - 3. Ignition: Electronically controlled electric spark with flame sensor.
 - 4. High-Altitude Kit For Project elevation
- C. Heat-Exchanger Drain Pan: Stainless steel.
- D. Venting: Gravity vented.
- E. Power Vent: Integral, motorized centrifugal fan interlocked with gas valve.
- F. Discharge Air Temperature Sensor. Duct mounted and integrated with gas controls for maintaining constant discharge air temperature.
- G. Safety Controls:
 - 1. Gas Control Valve: Electronic modulating
 - 2. Gas Train: Single-body, regulated, redundant, 24-V ac gas valve assembly containing pilot solenoid valve, pilot filter, pressure regulator, pilot shutoff, and manual shutoff.

2.6 OUTDOOR-AIR INTAKE AND DAMPERS

- A. Dampers: Leakage rate, according to AMCA 500, shall not exceed 2 percent of air quantity at face velocity of 2000 fpm through damper and pressure differential of 4-inch wg
- B. Damper Operators: Two Position - Electric. Belimo or Honeywell Actuators Only.
- C. Outdoor-Air Intake Hoods: Galvanized powder coated steel, with bird screen complying with ASHRAE 62.1-2015 and finish to match cabinet.

2.7 FILTERS

- A. Comply with NFPA 90A.
- B. Cleanable Filters: 1/2-inch thick, cleanable metal mesh at air inlet.
- C. Disposable Panel Filters: 2-inch thick, factory-fabricated, flat-panel or angle-type, disposable fiberglass air filters with cardboard frame.
 - 1. Holding Frame: Galvanized steel with slide trays.

2.8 CONTROLS

- A. Factory-wire connection for controls' power supply.
- B. Control devices, including sensors, duct sensors for mounting downstream, transmitters, relays, switches, thermostats, detectors, operators, actuators, and valves, shall be manufacturer's standard items to accomplish indicated control functions.
- C. Unit Controls: Solid-state control board and components with field-adjustable control parameters.
- D. Supply-Fan Control: Units shall be electrically interlocked with corresponding exhaust fans, to operate continuously when exhaust fans are running.
 - 1. Electrically interlock kitchen hood fire-extinguishing system to de-energize air unit when fire-extinguishing system discharges or when building fire alarm system is triggered. Provide automatic manual reset switch..
- E. Panel:
 - 1. Cooling/Off/Heating Controls: Wall Mounted or Kitchen Hood Mounted Panel. Control operational mode. Manual start stop. Heating/Cooling/Ventilation modes.
 - 2. Damper Position: Two Position type Indicates position of outdoor-air dampers in terms of percentage of outdoor air.
 - 3. Status Lights:
 - a. Filter dirty.
 - b. Fan operating.
 - c. Cooling operating.
 - d. Heating operating.
- F. Cooling System Controls:
 - 1. Unit-mounted water level controller and spray or water distribution system control. Integral with unit. Automatic fill and drain kit. Freeze protection kit for automatic draining of the water system when ambient temperature drops below 35 deg F.
- G. Heating Controls:
 - 1. Factory-mounted discharge air sensor in supply-fan outlet or duct with sensor adjustment located in control panel modulates gas furnace burner to maintain constant space temperature.
- H. Damper Controls: When exhaust fan stops, set outdoor damper to close. When exhaust fan starts, open outdoor-air damper.

- I. Integral Smoke Alarm: Smoke detector installed in supply air to shut-down fan upon detection of products of combustion.
- J. DDC Temperature Control: Stand-alone control module for link between unit controls and DDC temperature-control system. Control module shall be compatible with temperature-control system specified in Division 23 Section "Instrumentation and Control for HVAC." Links shall include the following:
 - 1. Start/stop interface relay, and relay to notify DDC temperature-control system alarm condition.
 - 2. Hardware interface or additional sensors for the following:
 - a. Discharge air temperature.
 - b. Cooling system operating.
 - c. Furnace operating.

2.9 MOTORS

- A. Comply with requirements in Division 23 Section "Common Motor Requirements for HVAC Equipment."

PART 3 - EXECUTION

3.1 INSTALLATION

- A. Install roof curb on roof structure. Install and secure rooftop make up air unit on curbs and coordinate roof penetrations and flashing with roof construction.
- B. Install wall or hood control panel, duct-mounting sensors, thermostats furnished by manufacturers for field installation. Install control wiring and make final connections to control devices and unit control panel.
- C. Piping installation requirements are specified in other Division 23 Sections. Drawings indicate general arrangement of piping, fittings, and specialties. Pipe gas, water and drain piping to rooftop make up air unit and make all required connections.
- D. Provide remote water fill and drain panel as indicated on the drawings.
- E. Install piping adjacent to machine to allow service and maintenance.
- F. Comply with requirements in Division 23 Section "Facility Natural-Gas Piping Connect gas piping to burner, full size of gas train inlet, and connect with union, pressure regulator, and shutoff valve with sufficient clearance for burner removal and service.
- G. Duct Connections: Duct installation requirements are specified in Division 23 Section "Metal Ducts." Drawings indicate the general arrangement of ducts. Connect supply ducts to rooftop make up-air units with flexible duct connectors. Provide insulated and jacketed duct connections to protect ductwork from the elements.
- H. Electrical Connections: Comply with requirements in Division 26 Sections for power wiring, switches, and motor controls.

- I. Ground equipment according to Division 26 Section "Grounding and Bonding for Electrical Systems."

3.2 STARTUP SERVICE

- A. Complete installation and startup checks according to manufacturer's written instructions. Issue start up report including heating, cooling and ventilation operations.
- B. Start heating and cooling systems when outdoor-air temperature is within normal operating limits and verify operation..
 1. Inspect and record performance of interlocks and protective devices including response to smoke detectors by fan controls and fire alarm.
 2. Operate unit for run-in period.
 3. Calibrate duct air discharge sensor
 4. Adjust and inspect high-temperature limits.
 5. Inspect outdoor-air dampers for proper stroke.
 6. Verify operational sequence of controls.
 7. Verify operation of remote panel including pilot-light operation and failure modes.
- C. After startup and performance testing, change filters, verify bearing lubrication, and adjust belt tension.
- D. Remove and replace components that do not pass tests and inspections and retest as specified above.
- E. Prepare written report of the results of startup services.

3.3 ADJUSTING

- A. Adjust initial temperature set points. Set discharge air temperature to 68 deg F
- B. Set field-adjustable switches and circuit-breaker trip ranges as indicated.

3.4 DEMONSTRATION

- A. Engage a factory-authorized service representative to train Owner's maintenance personnel to adjust, operate, and maintain rooftop make up air unit. Refer to Division 01 Section "Demonstration and Training."

END OF SECTION 23 7433

SECTION 23 8126 - INTERIOR VRF UNITS**PART 1 - GENERAL****1.1 SUMMARY**

- A. This Section includes interior wall mounted, split-system air-conditioning and heat pump units consisting of separate evaporator-fan and compressor-condenser components. Units are designed for exposed or concealed mounting, and may be connected to ducts.
- B. Design: Variable Refrigerant Flow (VRF) system consisting of variable capacity, heat pump heat recovery air conditioning system, roof mounted air cooled heat pump, indoor wall mounted evaporator cassettes with controls as indicated on the drawings.
- C. Contractor shall coordinate location of all wall mounted interior cassettes with owners representative.

1.2 SUBMITTALS

- A. Contractor Certificate verifying that the installing contractor has completed the VRF manufacturers installation, training and service courses.
- B. Product Data: For each unit indicated. Include performance data in terms of capacities, outlet velocities, static pressures, sound power characteristics, motor requirements, and electrical characteristics.
- C. Shop Drawings: Detailed equipment schematic drawings indicating arrangement of interior VRF units in association with their branch controllers, refrigeration piping, refrigeration piping sizes, and roof top mounted heat pumps. Include assemblies and indicate dimensions, weights, loads, required clearances, method of field assembly, components, and location and size of each field connection.
- D. Operation and maintenance data.
- E. Special warranties.

1.3 QUALITY ASSURANCE

- A. Electrical Components, Devices, and Accessories: Listed and labeled as defined in NFPA 70, Article 100, by a testing agency acceptable to authorities having jurisdiction, and marked for intended use.
- B. ASHRAE Compliance: Applicable requirements in ASHRAE 62.1-2004, Section 5 - "Systems and Equipment" and Section 7 - "Construction and Startup."
- C. ASHRAE/IESNA 90.1-2004 Compliance: Applicable requirements in ASHRAE/IESNA 90.1-2004, Section 6 - "Heating, Ventilating, and Air-Conditioning."
 - 1. Wiring Diagrams: Power, signal, and control wiring.

- D. Systems shall be designed and installed by a certified and authorized dealer with a minimum of 5 years experience in installation and service training. The mandatory contractor service and install training shall be verified by the manufacturer.
- E. Comply with NFPA 70.

1.4 WARRANTY

- A. Special Warranty: Manufacturer's standard form in which manufacturer agrees to repair or replace refrigeration components of air-source heat pumps that fail in materials or workmanship within five years from date of Substantial Completion.
- B. The entire system shall be installed by a certified and authorized VRF dealer. System shall be complete and certified functional by the Manufacturer's Representative.

PART 2 - PRODUCTS

2.1 INTERIOR VRF UNITS

- 1. Basis of Design: Mitsubishi
- 2. Additional Manufacturers: Subject to compliance with the specifications and requirements noted below additional manufacturers include:
 - a. LG Corporation
 - b. Daiken
- 3. The contractor and manufacturer shall provide to the project engineer a complete set of coordination drawings to insure that the various proposed mechanical system components are coordinated with each other and with other building systems. Drawings shall include a complete layout of system components and list of scheduled equipment, refrigeration pipe sizes, control schematics, electrical schedules, equipment appurtenances, equipment and piping supports and all other items shown on the original contract drawings.
- 4. Equipment layout drawings shall identify service and maintenance points, aisle ways and access ways, control panels, and shall show necessary maintenance clearances.
- 5. All piping and their attachments to the equipment shall be detailed, and shall be coordinated with the Owner's representative

2.2 EVAPORATOR-FAN UNIT

- A. Units shall be factory assembled, wired and run tested. Contained within the unit shall be all factory wiring, piping, electronic modulating linear expansion device, control circuit board and fan motor, The units shall have a self diagnostic function, 3-minute time delay mechanism, an auto restart function, an emergency operation function to provide for future servicing and test run switch.
- B. Unit Chassis: Galvanized baked enamel steel or powder coated steel with flanged edges, removable panels for servicing, and insulation on back of panel.

1. Insulation: Faced, glass-fiber duct liner.
 2. Drain Pans: Galvanized steel, with connection for drain; insulated[and complying with ASHRAE 62.1-2004].
 3. Airstream Surfaces: Surfaces in contact with the airstream shall comply with requirements in ASHRAE 62.1-2004.
 4. Manufacturers standard neutral color.
- C. Refrigerant Coil: Copper tube, with mechanically bonded aluminum fins, complying with ARI 210/240, and with thermal-expansion valve.
- D. Evaporator Fan: Forward-curved, double-width wheel of galvanized steel; statically and dynamically balanced, directly connected to motor. Discharge air grille shall have adjustable air direction.
- E. Condensate Lift Pump: Integral lift pump capable of lifting condensate a minimum of 24 inches above the condensate lift pan. Furnish with on/off level control, screened suction intake and discharge check valve.
- F. Fan Motor: Multispeed. 3 available speeds
- G. Filters: 1 inch thick, in fiberboard frames. MERV rating of 6 or higher.

2.3 CONTROLS:

- A. All interior VRF cassettes shall be provided with wall mounted thermostat or temperature control sensors provided by the manufacturer. Refer to Controls Specification for requirements.
- B. The control circuit between the indoor units, branch controllers and the outdoor heat pump units shall be 12 VDC completed using a 2-conductor, twisted pair shielded cable to provide total integration of the system.

2.4 ACCESSORIES

- A. Thermostat and Fan Speed Controller: See Controls Specification Section

PART 3 - EXECUTION

3.1 INSTALLATION

- A. Install evaporator-fan components using manufacturer's standard mounting devices securely fastened to building structure.
- B. Location of wall mounted cassette units shown on drawings is schematic. Contractor shall field verify final location of cassette unit with owner and engineer. Install wall mounted cassettes 8 inches below ceiling to facilitate return air operation. Locate wall mounted cassette units away from interior furniture, tables, desks and shelving units to provide for future servicing. Consider existing mechanical and electrical lighting and conduit prior to selecting final location of unit. Provide for manufacturers minimum service clearances around unit.
- C. Refrigeration piping connections to indoor VRF units shall be brazed copper.

- D. Install ceiling cassette units supported from overhead structure on restrained, spring isolators with a minimum static deflection of 1 inch .
- E. Remove, modify and replace ceiling tiles systems as needed as part of the ceiling cassette installation. Remove and modify existing ceiling grid systems and tracs as needed to facilitate installation of the ceiling cassette. Where required, infill open ceiling systems with new ceiling tiles.

3.2 CONNECTIONS

- A. Connect refrigeration piping to interior VRF units using brazed fittings. Provide isolation full port ball valves at each point of connection for servicing.
- B. Extend and connect refrigeration piping of size recommended by manufacturer, to the branch solenoid controllers. Make all required connections for a complete and functional heating and cooling system.
- C. Install piping adjacent to unit to allow service and maintenance.

3.3 FIELD QUALITY CONTROL

- A. Manufacturer's Field Service: Engage a factory-authorized service representative to inspect, test, and adjust field-assembled components and equipment installation, including connections, and to assist in field testing. Report results in writing.
- B. Leak Test: After installation, test for leaks as noted in Specification Section 23 2300 Refrigeration Piping. Repair leaks and retest until no leaks exist. Charge system accordingly.
- C. Operational Test: After electrical circuitry has been energized, start units to confirm proper motor rotation and unit operation. Remove malfunctioning units, replace with new components, and retest.
- D. Verify operation of branch controllers. Provide factory-authorized service representative to inspect, test, and adjust branch controller installation, including connections, and to assist in field testing. Report results in writing.
- E. Test and adjust controls and safeties. Replace damaged and malfunctioning controls and equipment.

END OF SECTION 23 8126

SECTION 23 8146 - AIR COOLED UNITARY HEAT PUMPS

PART 1 - GENERAL

1.1 SUMMARY

- A. This Section includes the following types of air cooled heat pumps used in VRF systems:
 - 1. Rooftop mounted air cooled heat pumps.
- B. Design: Variable Refrigerant Flow (VRF) system consisting of variable capacity, heat pump heat recovery air conditioning system, roof mounted air cooled heat pump, indoor wall mounted and ceiling mounted evaporator cassettes as indicated on the drawings.
- C. Manufacturer shall have a minimum of 25 years HVAC experience in the US market

1.2 SUBMITTALS

- A. Contractor Certificate verifying that the installing contractor has completed the VRF manufacturers installation, training and service courses.
- B. Product Data: Include rated capacities, furnished specialties, and accessories for each model.
- C. Shop Drawings: Detail equipment assemblies and indicate dimensions, weights, loads, required clearances, method of field assembly, components, and location and size of each field connection.
 - 1. Wiring Diagrams: Power, signal, and control wiring.
- D. Field quality-control test reports.
- E. Operation and maintenance data.
- F. Special warranties.

1.3 QUALITY ASSURANCE

- A. Electrical Components, Devices, and Accessories: Listed and labeled as defined in NFPA 70, Article 100, by a testing agency acceptable to authorities having jurisdiction, and marked for intended use.
- B. Systems shall be installed by a certified and authorized manufacturer's trained contractor with a minimum of 5 years experience in installation and service training. The mandatory contractor service and install training shall be verified by the manufacturer.
- C. ASHRAE Compliance:
 - 1. ASHRAE 15.
 - 2. Applicable requirements in ASHRAE 62.1-2004, Section 5 - "Systems and Equipment" and Section 7 - "Construction and Startup."

- D. ASHRAE/IESNA 90.1-2004 Compliance: Applicable requirements in ASHRAE/IESNA 90.1-2004, Section 6 - "Heating, Ventilating, and Air-Conditioning."
- E. Comply with NFPA 70.

1.4 WARRANTY

- A. Special Warranty: Manufacturer's standard form in which manufacturer agrees to repair or replace refrigeration components of water-source heat pumps that fail in materials or workmanship within five years from date of Substantial Completion.
- B. The entire system shall be installed by a certified manufacturer's trained contractor or dealer.
- C. System shall be complete and certified functional by a certified manufacturer's trained contractor or dealer.

PART 2 - PRODUCTS

2.1 AIR COOLED HEAT PUMPS

- 1. Basis of Design: Mitsubishi
- 2. Additional Manufacturers: Subject to compliance with the specifications and requirements noted below additional manufacturers include:
 - a. LG Corporation
 - b. Daiken - McQuay
- 3. The contractor and manufacturer shall provide to the project engineer a complete set of coordination drawings to insure that the various proposed mechanical system components are coordinated with each other and with other building systems. Drawings shall include a complete layout of system components and list of scheduled equipment, refrigeration pipe sizes, control schematics, electrical schedules, equipment appurtenances, equipment and piping supports and all other items shown on the original contract drawings.
- 4. Equipment layout drawings shall identify service and maintenance points, aisle ways and access ways, control panels, and shall show necessary maintenance clearances.
- 5. All piping and their attachments to the equipment shall be detailed, and shall be coordinated with the Owner's representative
- B. Description: Packaged heat pump with temperature controls; factory assembled, tested, and rated according to ARI-ISO-13256-1. The heat pump shall be used specifically with manufacturer's components. The heat pumps shall be equipped with multiple circuit boards that interface to the controls system and shall perform all functions necessary for operation. Each heat pump module shall be completely factory assembled, piped and wired and run tested at the factory.
- C. Packaged heat pump shall have a sound rating no higher than 64 dB(A). Units shall have a sound rating no higher than 50 dB(A) individually or 53 dB(A) twinned while in night mode operation. If an alternate manufacturer is selected, any additional material, cost, and labor to meet published sound levels shall be incurred by the contractor.

- D. The packaged heat pump shall have an accumulator with refrigerant level sensors and controls. The packaged heat pump shall have a high pressure safety switch, over-current protection, crankcase heater and DC bus protection.
- E. The refrigerant piping shall be copper and shall meet the length requirements of the project as per manufacturer's recommendations without the need for line size changes or traps.
- F. The packaged heat pump shall be capable of operating in heating mode down to -4°F ambient temperatures or cooling mode down to 23°F ambient temperatures, without additional low ambient controls.
- G. The packaged heat pump shall have a high efficiency oil separator plus additional logic controls to ensure adequate oil volume in the compressor is maintained.
- H. The packaged heat pump shall be provided with a manufacturer supplied snow /hail guard for all exposed surfaces. Exposed condenser fins are not acceptable.
- I. Cabinet and Chassis: Galvanized-steel casing with the following features:
 - 1. Access panel for access and maintenance of internal components.
 - 2. Knockouts for electrical and piping connections.
 - 3. Flanged duct connections.
 - 4. Cabinet Insulation: Glass-fiber liner, minimum 1/2 inch (13 mm) thick, complying with UL 181.
 - 5. Condensate Drainage: Plastic or stainless-steel drain pan with condensate drain piping projecting through unit cabinet[and complying with ASHRAE 62.1-2004].
 - 6. Airstream Surfaces: Surfaces in contact with the airstream shall comply with requirements in ASHRAE 62.1-2004.
 - 7. Sound Attenuation Package:
 - a. Minimum 0.598-inch- thick compressor enclosure and front panel. Minimum 0.0937-inch-thick foam gasket around the compressor and perimeter of end panel.
 - b. Sound attenuating blanket over compressor.
 - c. Hot-gas muffler.
- J. Fan: Direct driven, centrifugal, with multispeed motor resiliently mounted in fan inlet.
 - 1. General requirements for motors are specified in Division 23 Section "Common Motor Requirements for HVAC Equipment."
 - 2. Motor: Multispeed, permanently lubricated, ECM motor.
- K. Refrigerant-to-Air Coils: Copper tubes with aluminum fins, leak tested to 450 psig The outdoor coil shall be of nonferrous construction with lanced or corrugated plate fins on copper tubing. The coil fins shall have a factory applied corrosion resistant finish. The coil shall be protected with an integral metal guard. Refrigerant flow from the outdoor unit shall be controlled by means of an inverter driven compressor. The outdoor coil shall include multiple circuits with two position valves for each circuit, except for the last stage.
- L. Refrigerant Circuit Components:
 - 1. Sealed Refrigerant Circuit: Charge with R-410A refrigerant.
 - 2. Charging Connections: Service fittings on suction and liquid for charging and testing.
 - 3. Reversing Valve: Pilot-operated sliding-type valve designed to be fail-safe in heating position with replaceable magnetic coil.

4. Compressor: Inverter driven scroll hermetic compressor installed on vibration isolators and housed in an acoustically treated enclosure with factory-installed safeties as follows:
 - a. Antirecycle timer.
 - b. High-pressure cutout.
 - c. Low-pressure cutout or loss of charge switch.
 - d. Internal thermal-overload protection.
 - e. Freezestat to stop compressor if water-loop temperature in refrigerant-to-water heat exchanger falls below 35 deg F
 - f. Condensate overflow switch to stop compressor with high condensate level in condensate drain pan.
 5. Refrigerant Piping Materials: ASTM B 743 copper tube with wrought-copper fittings and brazed joints.
 6. Pipe Insulation: Refrigerant minimum 3/8-inch- thick, flexible elastomeric insulation on piping exposed to airflow through the unit. Maximum 25/50 flame-spread/smoke-development indexes according to ASTM E 84.
 7. Refrigerant Metering Device: Capillary tube.
 8. Hot-Gas Reheat Valve: Pilot-operated sliding-type valve with replaceable magnetic coil.
- M. Controls:
1. Basic Unit Microprocessor Controls:
 - a. Low- and high-voltage protection.
 - b. Overcurrent protection for compressor and fan motor.
 - c. Random time delay, three to ten seconds, start on power up.
 - d. Time delay override for servicing.
 - e. Control voltage transformer.
- N. Electrical Connection: Single point electrical connection with fused disconnect.
- O. Roof Support: Custom engineered and fabricated of galvanized steel angle of sufficient size and strength to support the air cooled heat pump above the existing roof at a minimum height of 12 inches. Roof supports shall be all welded construction with periodic tubular steel or angle steel column supports bearing off of the existing roof trusses. Contractor shall contract with the warranted roofing contractor to provide all roof flashings of column supports.
- P. Branch Distribution Controllers: The branch distributors provided to allow simultaneous heating and cooling by allowing either hot gas refrigerant to flow to indoor unit(s) for heating or subcooled liquid refrigerant to flow to indoor unit(s) for cooling. These units shall be equipped with a circuit board that interfaces to the controls system and shall perform all functions necessary for operation. The branch distributors shall be completely factory assembled, piped and wired. Each unit shall be run tested at the factory. This unit shall be mounted indoors, with access and service clearance provided for each distributor. The sum of connected capacity of all indoor air handlers shall range from 50% to 150% of rated capacity.
- Q. Refrigerant ball valves: Each branch of the distribution controller shall have multiple two-position ball valves to control refrigerant flow. Service shut-off valves are required and shall be field-provided/installed for every inlet line to each branch distributor, and every branch outlet to allow service to any indoor unit without field interruption to overall system operation.
- R. Linear electronic expansion valves shall be used to control the variable refrigerant flow.

- S. Future Use: Each VRF system shall include extra unused branches as shown on system schematics on plans for future use. Branches shall be fully installed & wired in central location with capped service shutoff valve & service port.
- T. Integral Drain Pan: An Integral drain pan and drain shall be provided
- U. Electrical: The unit shall be capable of satisfactory operation within voltage limits of 208V/60Hz
- V. The branch distributor shall be controlled by integral microprocessors.
- W. Controls:
 - 1. Basic Unit Controls:
 - a. Low- and high-voltage protection.
 - b. Overcurrent protection for compressor and fan motor.
 - c. Random time delay, three to ten seconds, start on power-up.
 - d. Time delay override for servicing.
 - e. Control voltage transformer.

PART 3 - EXECUTION

3.1 INSTALLATION

- A. Air Cooled Heat Pump Support: Install engineered, custom fabricated rail support system 12 inches above the existing roof, supported from existing roof structure, level and secure. Install and secure rooftop heat pumps to support rails using housed vibration spring isolators. Coordinate roof penetrations and flashing with warranted roofing contractor noted on the drawings. Secure heat pump units to rail support with anchor bolts.
- B. Paint Heat Pump Roof Support system with two coats of white enamel grade exterior paint. Primer coat all steel materials prior to painting.
- C. Drawings indicate general arrangement of piping, fittings, and specialties. Specific connection requirements are as follows:
 - 1. Connect supply and return refrigerant piping to heat pump with shutoff valves, filter driers, sight glasses and other noted items. Provide 3 valve bypass around filter drier for servicing purposes.
 - 2. Connect heat-pump condensate drain pan to drain to roof.
- D. Install electrical devices furnished by manufacturer but not specified to be factory mounted.
- E. Install piping adjacent to machine to allow service and maintenance.
- F. Ground equipment according to Division 26 Section "Grounding and Bonding for Electrical Systems."
- G. Connect wiring according to Division 26 Section "Low-Voltage Electrical Power Conductors and Cables."

3.2 FIELD QUALITY CONTROL

- A. Perform the following field tests and inspections and prepare test reports:
 - 1. After installing air cooled heat pumps and after electrical circuitry has been energized, test units for compliance with manufacturers requirements.
 - 2. Inspect for and remove shipping bolts, blocks, and tie-down straps.
 - 3. Operational Test: After electrical circuitry has been energized, start units to confirm proper motor rotation and unit operation.
 - 4. Test and adjust controls and safeties. Replace damaged and malfunctioning controls and equipment.
- B. Remove and replace malfunctioning units and retest as specified above.
- C. Install manufacturer's standard hail guards or louvers on all sides of the heat pump.

END OF SECTION 23 8146

SECTION 260500 - ELECTRICAL GENERAL PROVISIONS**PART 1 – GENERAL****1.1 RELATED DOCUMENTS:**

- A. Drawings and general provisions of Contract, including General and Supplementary Conditions and Division-1 Specification sections, apply to work of this section.
- B. Architectural, Structural, Mechanical and other applicable documents are considered a part of the electrical documents insofar as they apply as if referred to in full. Contractor must review the entire set of plans and specifications. Reviewing only the electrical set is not acceptable.

1.2 DESCRIPTION OF WORK:

- A. The extent of electrical work is indicated on drawings and/or specified in Divisions 26, 27 and 28 sections of the specification. Provide all labor, materials, equipment, supervision and service necessary for a complete electrical system. Work includes, but is not necessarily limited to, the following items.

<u>ITEM</u>	<u>SECTION</u>
1. Electrical General Provisions	26 0500
2. Electrical Submittals and Spare Parts	26 0502
3. Electrical Connections for Equipment	26 0507
4. Conductors and Cables	26 0519
5. Grounding	26 0526
6. Supporting Devices	26 0529
7. Conduit Raceway	26 0532
8. Electrical Boxes and Fittings	26 0533
9. Electrical Identification	26 0553
10. Occupancy Sensors	26 0923
11. Lighting Control Equipment	26 0943
12. Panelboards	26 2416
13. Wiring Devices	26 2726
14. Overcurrent Protective Devices	26 2815
15. Motor and Circuit Disconnects	26 2816
16. Motor Starters	26 2913
17. Demolition	26 4119
18. Interior and Exterior Building Lighting	26 5100
19. Telephone/Data Systems	27 1500
20. Fire Alarm and Detection System	28 3111

- B. Use of standard industry symbols together with the special symbols, notes, and instructions indicated on the drawings describe the work, materials, apparatus and systems required as a portion of this work.
- C. Visit the site during the bidding period to determine existing conditions affecting electrical and other work. All costs arising from site conditions and/or preparation shall be included in the base bid. No additional charges will be allowed due to inadequate site inspection.

1.3 DEFINITION OF TERMS

- A. The following terms used in Divisions 26, 27 and 28 documents are defined as follows:
1. "Provide": Means furnish, install and connect, unless otherwise indicated.
 2. "Furnish": Means purchase and deliver to project site.
 3. "Install": Means to physically install the items in-place.
 4. "Connect": Means make final electrical connections for a complete operating piece of equipment.

1.4 RELATED SECTIONS:

- A. Consult all other sections, determine the extent and character of related work and properly coordinate work specified herein with that specified elsewhere to produce a complete installation.
- B. General and Supplementary Conditions: Drawings and general provisions of contract and Division 1 of the Specifications, apply to all Division 26, 27 and 28 sections.
- C. Earthwork:
1. Provide trenching, backfilling, boring and soil compaction as required for the installation of underground conduit, buried cable, in-grade pull boxes, manholes, lighting pole foundations, etc. See Division 31, Sitework, and other portions of Divisions 26, 27 and 28, for material and installation requirements.
- D. Concrete Work:
1. Provide forming, steel bar reinforcing, cast-in-place concrete, finishing and grouting as required for underground conduit encasement, light pole foundations, pull box slabs, vaults, equipment pads, etc. See Division 3, Concrete for material and installation requirements.
- E. Miscellaneous Metal Work:
1. Provide fittings, brackets, backing, supports, rods, welding and pipe as required for support and bracing of raceways, lighting fixtures, panelboards, distribution boards, switchboards, motor controls centers, etc. See Division 5, Metals for material and installation requirements.
- F. Miscellaneous Lumber and Framing Work:
1. Provide wood grounds, nailers, blocking, fasteners, and anchorage for support of electrical materials and equipment. See Division 6, Rough Carpentry for material and installation requirements.
- G. Moisture Protection:
1. Provide membrane clamps, sheet metal flashing, counter flashing, caulking and sealants as required for waterproofing of conduit penetrations and sealing penetrations in or through fire walls, floors and ceiling slabs and foundation walls. All penetrations through vapor barriers at slabs on grade shall be taped and made vapor tight. See Division 7, Thermal and Moisture Protection for material and installation requirements.
- H. Access panels and doors:
1. Provide in walls, ceiling, and floors for access to electrical devices and equipment. See Division 8, Doors and Windows for material and installation requirements.
- I. Painting:
1. Provide surface preparation, priming and finish coating as required for electrical cabinets, exposed conduit, pull and junction boxes, poles, surface metal raceways, etc. See Division 9, Finishes for material and installation requirements.

1.5 WORK FURNISHED AND INSTALLED UNDER ANOTHER SECTION REQUIRING CONNECTIONS UNDER THIS SECTION:

- A. Provide electrical service, make requisite connections and perform operational test. Items furnished and installed under other sections and connected under this section, include but are not limited to the following:
1. Electric motors.
 2. Package mechanical equipment: fans, fan coil units, pumps, boilers, duplex compressors, etc.
 3. Flow switches and valve monitors.
 4. Motorized dampers.
 5. Roll down doors.
 6. Kitchen equipment including ovens, fryers, mixers, disposers, dishwashers, etc.

1.6 ITEMS FURNISHED UNDER ANOTHER DIVISION, BUT INSTALLED AND CONNECTED UNDER THIS DIVISION:

- A. Items furnished under other Divisions, but turned over to Division 26 for installation and final connection include, but are not necessarily limited to, the following:
1. Wall mounted control stations for motorized roll-up doors/grills.
 2. Lighting fixtures for kitchen hoods.
 3. Lighting fixtures for walk-in freezers and coolers.

1.7 WORK NOT INCLUDED IN THIS DIVISION:

- A. Items of work provided under another contract include, but are not necessarily limited to, the following:
1. Telephone cables and electronic equipment.
 2. Control wires for irrigation control valves.
 3. Energy management/temperature control system; both line and low voltage including conductors and conduit.
 4. Television monitors and projection equipment.
 5. Security system equipment, cables, fittings, and coverplates.
 6. CCTV cabling and electronic equipment.
 7. MATV cabling and electronic equipment.

1.8 INTERPRETATION OF DRAWINGS AND SPECIFICATIONS:

- A. Before bidding, Contractor shall familiarize himself with the drawings, specifications and project site. Submit requests for clarification to Architect/Engineer in writing prior to issuance of final addendum. After signing the contract, the Contractor shall meet the intent, purpose, and function of the Contract Documents. Any costs of materials, labor and equipment arising therefrom, to make each system complete and operable, is the responsibility of the Contractor.

1.9 QUALITY ASSURANCE:

- A. Reference to codes, standards, specifications and recommendations of technical societies, trade organizations and governmental agencies refers to the latest edition of such publications adopted and published prior to submittal of the bid proposed, unless noted otherwise herein. Such codes or standards are considered a part of this

specification as though fully repeated herein.

- B. When codes, standards, regulations, etc. allow work of lesser quality or extent than is specified under this Division, nothing in said codes shall be construed or inferred as reducing the quality, requirements or extent of the Drawings and Specifications. Perform work in accordance with applicable requirements of all governing codes, rules and regulations including the following minimum standards, whether statutory or not:
 - 1. National Electric Code (NEC).
 - 2. International Building Code (IBC).
 - 3. International Fire Code (IFC).
 - 4. International Mechanical Code (IMC).
- C. Standards: Comply with the following standards where applicable for equipment and materials specified under this Division.
 - 1. UL Underwriters' Laboratories
 - 2. ASTM American Society for Testing Materials
 - 3. CBN Certified Ballast Manufacturers
 - 4. IPCEA Insulated Power Cable Engineers Association
 - 5. NEMA National Electrical Manufacturer's Association
 - 6. ANSI American National Standards Institute
 - 7. ETL Electrical Testing Laboratories
- D. All electrical apparatus furnished under this Section shall conform to (NEMA) standards and the NEC and bear the Underwriters' Laboratories (UL) label where such label is applicable.
- E. Comply with requirements of State and Local Ordinances. If a conflict occurs between these requirements and the Contract Documents, the most stringent requirements shall govern. The Contractor accepts this responsibility upon submitting his bid, and no extra charge will be allowed after the contract is awarded. This shall not be construed as relieving the Contractor from complying with any requirements of the Contract Documents that may be in excess of the aforementioned requirements, and not contrary to same.
- F. Obtain all permits, inspections, etc. required by authority having jurisdiction. Include all fees in bid. Furnish a certificate of approval to the Owner's Representative from the Inspection Authority at completion of the work.
- G. Employ only qualified craftsmen with at least three years of experience. Workmanship shall be neat, have a good mechanical appearance and conform to best electrical construction practices. Provide a competent superintendent to direct the work at all times. Any person found incompetent shall be discharged from the project and replaced by satisfactory personnel.
- H. Contractor shall have a current state contracting license applicable to type of work to be performed under this contract.
- I. Required Pre-Electrical Construction Meeting with Electrical Engineer: Electrical contractor/representative will be required to attend a pre-electrical construction meeting (approximately 30-60 minutes) with engineering representative in the electrical engineers office prior to electrical construction commencement. This meeting will address any questions on the part of the contractor and the expectations of the Engineer with regard to specifications, plans and site visits for both rough and finish electrical work.

1.10 CONSTRUCTION CHANGE ORDER PROPOSALS

- A. In the event that a submission of a change order is issued by the contractor, the following information will be required to be submitted by the contractor, prior to any consideration by the owner/architect.
- a. Where project manager or project engineer work is required, the labor cost shall not exceed 2% of the electrical portion of the change order.
 - b. All equipment, including conduit and wire, shall be itemized, identifying unit costs and quantities of equipment. Distributor quotes shall accompany all change order requests. The distributor quotes shall include costs for all equipment including conduit and wire. Lot pricing for equipment is not acceptable.
 - c. The general contractor shall review and confirm that the quantity and costs of materials submitted appear reasonable for the scope proposed.
 - d. Labor units shall not exceed base NECA #1 standards. No adjustment factors shall be approved.
 - e. Any research and labeling time, shall be the responsibility of the electrical contractor and shall not be included in the change order request.
 - f. Any costs associated with the purchase of tools or transportation shall be fully itemized for review by architect/owner.
 - g. Overtime rates shall only be approved where additional manpower cannot achieve the same result.
 - h. Change order form shall follow the following format:
 - i. PCO number
 - ii. Detailed description of work being performed
 - iii. Location on project where work is performed
 - iv. Chosen NECA column
 - v. Identified material:
 1. QTY
 2. Unit cost
 3. Mark up
 4. Material total
 - vi. Identified labor:
 1. QTY
 2. Unit cost
 3. Composite labor rate
 4. Labor total

1.11 SUBMITTALS: Refer to Section 26 0503 for requirements.

1.12 RECORD DRAWINGS:

- A. Maintain, on a daily basis, a complete set of "Record Drawings", reflecting an accurate record of work in accordance with the following:
1. Show the complete routing and location of all feeders rated 100 amps and larger. Locate work buried below grade or under slab, work concealed above ceilings, and work in concealed spaces, dimensionally from fixed structural elements (not partition walls, etc.)
 2. Show the complete routing and location of all telecommunications conduits, systems raceways, and empty raceways, 1-1/4" and larger. Locate work buried below grade or under slab, work concealed above ceilings, and work in concealed spaces, dimensionally from fixed structural elements (not partition walls, etc.).
 3. Show all changes, deviations, addendum items, change orders, job instructions, etc., that change the work from that shown on the contract documents, including

wall relocations, fixtures and device changes, branch circuiting changes, etc. Where locations of boxes, raceways, equipment, etc. are adjusted in the field to fit conditions, but such new locations may not be obvious by referring to the contract document, show new locations on the record drawings.

- B. At the discretion of the Architect/Engineer, the drawings will be reviewed on a periodic basis and used as a pre-requisite for progress payments. This requirement shall not be construed as authorization for the Contractor to make changes in the layout, or work without written authorization for such changes. The "Record Drawings" for daily recording shall consist of a set of blue line prints of the Contract Drawings.
- C. Upon completion of the work, purchase a complete set of electronic drawings. Transfer all "Record" information from the blue line prints to the drawings via the current CAD program that it was written. The Architect/Engineer shall review the drawings and the Contractor shall incorporate the resulting comments into the final record drawings. The Contractor shall make two complete copies of the drawings electronically and forward this to the Engineer.
- D. Certify the "Record Drawings" for correctness by placing and signing the following certifications of the first sheet of the drawings:

"CERTIFIED CORRECT (3/8" high letters)

(Name of General Contractor)

By: _____ Date: _____

(Name of Electrical Contractor)

By: _____ Date: _____

1.13 GUARANTEE:

- A. Ensure that electrical system installed under this contract is in proper working order and in compliance with drawings, specifications, and/or authorized changes. Without additional charge, replace any work or materials that develop defect, except from ordinary wear and tear, within one year from the date of substantial completion. Exception: Incandescent and fluorescent lamps shall be guaranteed for a period of two months from the date of substantial completion.

PART 2 – PRODUCTS

2.1 GENERAL:

- A. Products are specified by manufacturer name, description, and/or catalog number. Discrepancies between equipment specified and the intended function of equipment shall be brought to the attention of the Architect/Engineer in writing prior to bidding. Failure to report any conflict, including catalog numbers, discontinued products, etc., does not relieve the Contractor from meeting the intent of the contract documents nor shall it change the contract cost. If the Contractor is unable to interpret any part of the plans and/or specifications, or should he find discrepancies therein, he shall bring this to the attention of the Architect/Engineer who will issue interpretation and/or additional instructions to Bidders before the project is bid.

2.2 MANUFACTURERS:

- A. Provide products of manufacturers specified. Manufacturers catalog numbers and descriptions establish the quality of product required. Substitutions will be considered if a duplicate written application (2-copies) is at the office of the Architect/Engineer eight (8)

working days prior to the day of the bidding. The application shall include the following: 1) A statement certifying that the equipment proposed is equal to that specified; that it has the same electrical and physical characteristics, compatible dimensions, and meets the functional intent of the contract documents; 2) The specified and submittal catalog numbers of the equipment under consideration; 3) A pictorial and specification brochure.

- B. Any conflict arising from the use of substituted equipment shall be the responsibility of the Contractor, who shall bear all costs required to make the equipment comply with the intent of the contract documents.
- C. Samples may be required for non-standard or substituted items before installation during construction. Provide all samples as required.
- D. No materials or apparatus may be substituted after the bid opening except where the equipment specified has been discontinued.
- E. Provide only equipment specified in the Contract Documents or approved by addendum.

2.3 SPARE PARTS:

- A. Provide spare parts (fuses, diffusers, lamps, etc.) as specified. Transmit all spare parts to Owner's Representative prior to substantial completion.

PART 3 – EXECUTION

3.1 INSTALLATION:

- A. Layout electrical work in advance of construction to eliminate unnecessary cutting, drilling, channeling, etc. Where such cutting, drilling, or channeling becomes necessary for proper installation; perform with care. Use skilled mechanics of the trades involved. Repair damage to building and equipment at no additional cost to the contract. Cutting work of other Contractors shall be done only with the consent of that Contractor. Cutting structural members shall not be permitted.
- B. Provide equipment enclosures appropriate to the environment to which they are installed. For example, provide NEMA 3R for exterior enclosures and NEMA 1 for interior enclosures unless otherwise noted.
- C. Since the drawings of floor, wall, and ceiling installation are made at small scale; outlets, devices, equipment, etc., are indicated only in their approximate location unless dimensioned. Locate outlets and apparatus symmetrically on floors, walls and ceilings where not dimensioned, and coordinate such locations with work of other trades to prevent interferences. Verify all dimensions on the job. Do not scale the electrical drawings, but refer to the architectural and mechanical shop drawings and project drawings for dimensions as applicable.
- D. Perform for other trades, the electrical wiring and connection for all devices, equipment or apparatus. Consult Architectural, Mechanical, and other applicable drawings, and all applicable shop drawings to avoid switches, outlets, and other equipment from being hidden behind doors, cabinets, counters, heating equipment, etc., or from being located in chalkboards, tackboards, glass panels, etc. Relocate buried electrical devices and/or connections as directed at no additional cost.
- E. Coordinate the location of outlets, devices, connections, and equipment with the supplier of the systems furniture prior to rough-in.
- F. Where conduit, outlets or apparatus are to be encased in concrete, it must be located and secured by a journeyman or foreman present at the point of installation. Check locations of the electrical items before and after concrete and/or masonry installation and relocate displaced items.

- G. Provide block-outs, sleeves, demolition work, etc., required for installation of work specified in this division.

3.2 CLEAN:

- A. Clean up all equipment, conduit, fittings, packing cartons and other debris that is a direct result of the installation of the work of this Division.
- B. Clean fixtures, interiors and exteriors of all equipment, and raceways. Replace all filters in electrical equipment upon request for Substantial Completion.

3.3 POWER OUTAGES:

- A. All power outages required for execution of this work shall occur during non-standard working hours and at the convenience of the Owner. Include all costs for overtime work in bid.
- B. Submit written request at least 7 days in advance of scheduled outage and proceed with outage only after receiving authorization from the Owner's Representative.
- C. Keep all outages to an absolute minimum.

3.4 STORAGE AND PROTECTION OF MATERIALS:

- A. Provide storage space for storage of materials and apparatus and assume complete responsibility for all losses due to any cause whatsoever. In no case shall storage interfere with traffic conditions in any public thoroughfare or constitute a hazard to persons in the vicinity. Protect completed work, work underway, and apparatus against loss or damage.

3.5 EXCAVATING FOR ELECTRICAL WORK:

- A. General: Locate and protect existing utilities and other underground work in manner that will ensure that no damage or service interruption will result from excavating and backfilling. Perform excavation in a manner that protects walls, footings, and other structural members from being disturbed or damaged in any way. Burial depths must comply with NEC Section 300-5 (or State of Utah requirement, whichever is more stringent), unless noted otherwise on drawings.
- B. Protect persons from injury at excavations, by barricades, warnings and illumination.
- C. Coordinate excavations with weather conditions, to minimize possibility of washouts, settlements and other damages and hazards.
- D. Provide temporary covering or enclosure and temporary heat as necessary to protect bottoms of excavations from freezing and frost action. Do not install electrical work on frozen excavation bases or sub-bases.
- E. Do not excavate for electrical work until the work is ready to proceed without delay, so that total time lapse from excavation to completion of backfilling will be minimum. See other sections of specification for additional requirements for excavating.
- F. Store excavated material (temporarily) near excavation, in a manner that will not interfere with or damage excavation or other work. Do not store under trees (within drip line).
- G. Retain excavated material that complies with requirements for backfill material. Dispose of excavated material that is either in excess of quantity needed for backfilling or does not comply with requirements for backfill material. Remove unused material from project site, and dispose of in lawful manner.

3.6 BACKFILL MATERIALS:

- A. For buried conduit or cable (other than below slab-on-grade, or concrete encased) - 2" thickness of well graded sand on all side of conduit or cable.
- B. For trench backfill to within 6" of final grade - soil material suitable for compacting to required densities.
- C. For top 6" of excavation - Top soil.
- D. Backfill excavations in 8" high courses of backfill material, uniformly compacted to the following densities (percent of maximum density, ASTM D 1557), using power-driven hand-operated compaction equipment.
 - 1. Lawn/Landscaped Areas: 85 percent for cohesive soils, 95 percent for cohesionless soils.
 - 2. Paved Areas, Other than Roadways (90 percent for cohesive soils, 95 percent for cohesionless soils).
- E. Subsidence: Where subsidence is measurable or observable at electrical work excavations during general project warranty period, remove surface (pavement, lawn or other finish), add backfill material, compact, and replace surface treatment. Restore appearance, quality and condition of the surface or finish to match adjacent work, and eliminate evidence of restoration to greatest extent possible.

3.7 ROOF PENETRATIONS:

- A. Where raceways penetrate roofing or similar structural area, provide appropriate roof jack coordinate with the roofing contractor and the Architect in order to match the vent with the roof construction. The jack shall be sized to fit tightly to raceway for weather-tight seal, and with flange extending a minimum of 9" under roofing in all sides or as required by the roof type of construction. Completely seal opening between inside diameter of roof flashing and outside diameter of penetrating raceways. Coordinate all work with work required under roofing section of specifications.

3.8 FIRE PENETRATION SEALS:

- A. Seal all penetrations for work of this section through fire rated floors, walls and ceilings to prevent the spread of smoke, fire, toxic gas or water through the penetration either before, during or after fire. The fire rating of the penetration seal shall be at least that of the floor, wall or ceiling that it is installed, so that the original fire rating of the floor or wall is maintained as required by Article 300-21 of the National Electrical Code. Where applicable, provide OZ Type CFSF/I and CAFSF/I fire seal fittings for conduit and cable penetrations through concrete and masonry walls, floors, slabs, and similar structures. Where applicable, provide [3M](#) CID cast-in device for floor slabs. Where applicable, provide [3M](#) fire barrier sealing penetration system, and/or IPC Flame Safe Fire Stop System, and/or Chase Foam fire stop system, including wall wrap, partitions, caps, and other accessories as required. All materials to comply with UL 1479 (ASTM E-814). Comply with manufacturer's instructions and recommendations for installation of sealing fittings and barrier sealing systems.

3.9 PROJECT FINALIZATION AND START-UP:

- A. Upon completion of equipment and system installation, assemble all equipment Factory Representatives and Subcontractors for system start-up.
- B. Each Representative and Subcontractor shall assist in start-up and check out their respective system and remain at the site until the total system operation is accepted by the Owner's representative.
- C. The Factory Representative and/or System Subcontractor shall give personal instruction

on operating and maintenance of their equipment to the Owner's maintenance and/or operation personnel. To certify acceptance of operation and instruction by the Owner's Representative, the contractor shall prepare a written statement as follows:

1. This is to certify that the Factory Representative and System Subcontractor for each of the systems listed below have performed start-up and final check out of their respective systems.
2. The Owner's Representative has received complete and thorough instruction in the operation and maintenance of each system.

SYSTEM	FACTORY REPRESENTATIVE
(List systems included)	(List name and address of Factory Representative)

_____	_____
Owner's Representative	Contractor

- D. Send copy of acceptance to Architect/Engineer.

3.10 FINAL REVIEW:

- A. At the time of final review, the project foreman shall accompany the reviewing party, and remove coverplates, panel covers and other access panels as requested, to allow review of the entire electrical system.

END OF SECTION 260500

SECTION 260502 - ELECTRICAL SUBMITTALS AND SPARE PARTS

PART 1 – GENERAL

1.1 RELATED DOCUMENTS:

- A. Drawings and general provisions of Contract, including General and Supplementary Conditions and Division-1 Specification sections, apply to all Division 26, 27 and 28 sections.
- B. Architectural, Structural, Mechanical and other applicable documents are considered a part of the electrical documents insofar as they apply as if referred to in full. Contractor must review the entire set of plans and specifications. Reviewing only the electrical set is not acceptable.
- C. Consult all other sections, determine the extent and character of related work and properly coordinate work specified herein with that specified elsewhere to produce a complete installation.

1.2 SUBMITTAL REQUIREMENTS:

A. GENERAL:

1. After the Contract is awarded but prior to ordering, manufacture, or installation of any equipment, prepare complete Submittals including shop drawings, product data, brochures, etc. for materials and equipment as required by each section of the specification.
2. Review of Submittals shall not relieve the Contractor of responsibility for dimensions and/or errors that may be contained therein, or deviations from the Contract Document's requirements. It shall be clearly understood that the noting of some errors but overlooking others does not grant the Contractor permission to proceed in error. Regardless of any information contained in the Shop Drawings and Brochures, the requirements of the Contract Document's shall govern and are not waived, or superseded in any way by the review of the Shop Drawings and Brochures.
3. Submittals are reviewed, not approved. Comments made within submittals do not alter the contract documents in any way. The contractor is still responsible, regardless of comments (if any) made within submittals, for complying with drawings and specifications.
4. Notify engineer in writing if any of the comments noted in the submittals alter the contract cost. A comment within the submittal process which increases/decreases cost of product is not an authorization to the contractor under any circumstances to proceed.
5. Notify engineer of any modifications between contract documents and submittals. It is the responsibility of the contractor to ensure compliance.
6. ELECTRONIC SUBMITTAL REQUIREMENTS:
 - a. Provide submittals in Portable Document Format (PDF).
 - b. Documents must be electronically bookmarked and keyword searchable using Adobe Acrobat (<http://www.adobe.com/acrobat>) or Bluebeam Revu (<http://www.bluebeam.com>) for each relevant section. For example, include electronic bookmarks separating "Light Fixtures" from "Panelboards".

- c. Electronically highlight all options for light fixtures, electrical equipment, etc. Manual highlighting and scanning of the documents is NOT acceptable and will NOT be reviewed.
- d. Provide only completed cutsheets for all fixture and equipment types. Blank cutsheets submitted with a schedule are NOT acceptable and will NOT be reviewed.
- e. At the time of submission, the electrical contractor shall provide a complete and comprehensive submission of all required specification sections/shop drawings at the same time. Exceptions may be given, with prior approval, for time-sensitive equipment.
- f. A maximum of one submittal per specification section is allowed. It is NOT acceptable to provide a product by product submittal. Single product by product submittals will NOT be reviewed.

B. SCHEDULING

1. GENERAL

- a. A minimum period of two weeks, exclusive of transmittal time, will be required each time Submittals are submitted or resubmitted for review. This time period shall be considered by the Contractor when scheduling submittal data.
- b. If the shop drawings are rejected twice, the contractor shall reimburse the engineer the sum of \$1,200.00 for the third review and any additional reviews required prior to commencement of the third review.

C. QUALITY ASSURANCE

1. PRE-SUBMITTAL PREPARATION

- a. Prior to submission of the Shop Drawings and Project Data, review and certify that they are in compliance with the Contract Documents. Verify all dimensional information to ensure proper clearance for installation of equipment.
- b. Shop drawings requiring the use of electronic documents (floor plans, Lighting plans, fire alarm plans, etc.) shall be requested via a request for information (RFI) through the general contractor. Electronic documents will be provided to the Architect for distribution. No direct vendor requests will be accepted.
- c. Contractor is completely responsible for the content of the submittal

2. SUBMITTAL REQUIREMENTS

- a. Certifications shall be written or in the form of rubber stamp impressions as follows:
 - i. I hereby certify that this Shop Drawing and/or Brochure has been checked prior to submittal and that it complies in all respects with the requirements of the Contract Drawings and Specifications for this Project.

(Name of Electrical Subcontractor)

Name _____.

Position _____ Date _____

- b. Brochures to be submitted shall be published by the Manufacturers and shall contain complete and detailed engineering and dimensional information. Brochures submitted shall contain only information relevant to

the particular equipment or materials to be furnished. The Contractor shall not submit catalogs that describe several different items in addition to those items to be used, unless all irrelevant information is marked out, or unless relevant information is clearly marked. Brochures from each manufacturer shall be identified and submitted separately.

- c. Shop Drawings shall be done in an easily legible scale and shall contain sufficient plans, elevations, sections, and isometrics to clearly describe the equipment or apparatus, and its location. Drawings shall be prepared by an Engineer/Draftsmen skilled in this type of work. Shop Drawings shall be drawn to at least 1/4" = 1'0" scale.
- d. Observe the following rules when submitting the Shop Drawings and Brochures.

- i. Each Shop Drawing shall indicate in the lower right hand corner, and each Brochure shall indicate on the front cover the following: Title of the sheet or brochure, name and location of the building; names of the Architect and Electrical Engineer, Contractor, Subcontractors, Manufacturer, Supplier/Vendor, etc., date of submittal, and the date of correction and revision. Unless the above information is included the submittal will be returned for resubmittal.

- 1. Submittal Identification shall include the following:

- a. A unique number, sequentially assigned, shall be noted on the transmittal form accompanying each item submitted.
- b. Original submittal numbers shall have the following format: "XXX-Y;" where "XXX" is the originally assigned submittal number and "Y" is a sequential letter assigned for resubmittals (for example, A, B, or C being the first, second, and third resubmittals, respectively). Submittal 25B, for example, is the second resubmittal of Submittal 25.

- e. SPECIFICATION section and paragraph to which submittal applies.

D. POST-SUBMITTAL

- 1. Check all materials and equipment after arrival on the job site and verify compliance with the Contract Documents.

1.3 Provide submittals as requested for each of the sections listed below:

A. 26 0519 Conductors and Cables

- 1. (600V and Below)
 - a. Submit megohmmeter test data for circuits under 600 volts.
- 2. Conductors and Cables (Medium and Low Voltage)
 - a. Submit manufacturer's data on electrical cable and connectors for use above 600 volts. Upon request of Architect/Engineer, submit certificate of compliance indicating that cable has been tested in accordance with ICEA

- S-68-516, AE16 #6 and UL Standard 1072, and meets or exceeds minimum requirements.
- b. Submit test data in accordance with IEEE Standard 400-2001 showing ambient conditions, voltage levels, level durations, and conduction current for each step. Include effective insulation resistance in submittal.
- B. 26 0526 Grounding
1. Submit the name of test agency to be used for testing specified in this section. Submit results of tests specified in this section. Also include test results in Operation and Maintenance Manuals as specified.
- C. 26 0532 Conduit Raceway
1. Submit manufacturer's data on Power & Control/Signal Cable.
- D. 26 0533 Electrical Boxes and Fittings
1. Submit manufacturer's data including specifications, installation instruction and general recommendations for each type of floor box used on project.
- E. 26 0553 Electrical Identification
1. Submit manufacturer's data on each type of electrical identification products
- a. Submit one sample of each component of the electrical identification system as follows: Wire/cable tape marker, Tags, Engraved, plastic laminate labels, Arc-flash hazard labels
- F. 26 0923 Occupancy Sensors
1. Submit manufacturer's data on occupancy sensors, control modules, wiring diagrams, interconnection diagrams and any related accessories.
2. Submit scaled drawings with lighting fixtures shown clearly marked by manufacturer showing proper product, location and orientation of each sensor.
- G. 26 0943 Lighting Control Equipment
1. Submit manufacturer's data on lighting control equipment including, but not limited to published catalog data sheets, rough-in diagrams and instructions for installation, operating and maintenance, suitable for inclusion in maintenance manuals.
2. Meet with the electrical engineer at their office prior to preparation of shop drawings to discuss and verify specific programming and zoning requirements of system(s).
3. Meet with the lighting representative/manufacturer of the approved and accepted lighting control equipment to verify and understand specific installation requirements associated with that system.
4. Submit detailed drawings and documentation of lighting control components and interconnection including, but not necessarily limited to:
- a. Electronic controllers
- b. Control stations
- c. Photo sensors
- d. Occupancy sensors
- e. Network wiring details

- f. Input and output wiring details
 - g. Lighting control panel load schedules
 - h. Provide a complete sequencing and programming schedules for all devices, zones and scenes.
 - i. Wallstations layouts
 - j. Accurately scaled equipment layouts, wire/cable routing and connections to control wiring and electrical power feeders.
- H. 26 2416 Panelboards
- 1. Submit dimensioned drawings of panelboards and enclosures showing accurately scaled layouts of enclosures and required individual panelboard devices, including but not necessarily limited to, circuit breakers, fusible switches, fuses, ground-fault circuit interrupters, and accessories.
 - 2. Submit manufacturer data including specifications, installation instructions and general recommendations, for each type of panelboard required.
 - 3. Submit manufacturer's data and shop drawings only after completion of the preliminary protective device study (see Section 26 0573 as applicable). Any Section 26 2416 submittals received prior to submission of the preliminary protective device study will be REJECTED.
- I. 26 2726 Wiring Devices
- 1. Submit manufacturer's data on electrical wiring devices.
- J. 26 2815 Overcurrent Protective Devices
- 1. Submit manufacturer's data on overcurrent protective devices, including catalog cuts, time-current trip characteristic curves, and mounting requirements.
 - 2. Submit layout drawings of overcurrent protective devices, with layouts of circuit breakers, including spatial relationships to proximate equipment. Failure to submit said spatial layouts does not relieve contractor of responsibility to verify all required clearances before release of equipment for fabrication.
 - 3. Submit manufacturer's data and shop drawings only after completion of the preliminary protective device study (see Section 26 0573 as applicable). Any Section 26 2815 submittals received prior to submission of the preliminary protective device study will be REJECTED.
 - 4. For types and ratings required, furnish additional fuses, amounting to one unit for every 5 installed units, but not less than two units of each size and type, unless specified otherwise in another section of these specifications.
 - 5. Submit time-current trip curves (in log-log format) and trip setting parameter/range information (for each trip function) for all solid-state circuit breakers.
 - 6. Manufacturer shall also provide recommended trip settings with the shop drawing submittal (including ground fault settings) for coordination with downstream overcurrent devices. Manufacturer shall base recommendations on the AIC rating of the electrical equipment.
- K. 26 2816 Motor and Circuit Disconnects
- 1. Submit manufacturer's data including specifications, installation and general recommendations, for each type of motor and circuit disconnect switch required.
 - 2. Submit dimensioned drawings of electrical motor and circuit disconnect switches that have rating of 100 amperes and larger.

- L. 26 2913 Motor Starters
1. Submit manufacturer's data on motor starters.
 2. Submit dimensioned drawings of motor starters showing accurately scaled equipment layouts.
 3. After installation is complete, including water and air balancing, measure voltage (L-L and L-N) and full load current of each phase of each motor. Submit report showing field readings of voltage, amperage, service factor, and thermal heater size installed for each motor.
- M. 26 5100 Interior and Exterior Building Lighting
1. Submit manufacturer's data on interior and exterior building lighting fixtures.
 2. Submit dimensioned drawings of lighting fixtures. Submit fixture shop drawings in PDF format with separate sheet for each fixture, assembled in luminaire "type" alphabetical order, with proposed fixture catalog number and accessories clearly indicated on each sheet.
 3. When applicable submit standard color samples with the shop drawings. If standard colors are not acceptable, a color sample will be provided to the fixture manufacturer. Return of the shop drawings will be delayed until color samples are provided.
 4. Submit ballast and driver manufacturer cut sheets.
 5. Submit a list of all lamps used on projects.
 6. Provide a complete spare parts list in lighting shop drawing review.
 - a. Stock of all spare items shall be delivered as directed to Owner's storage space. All components shall be labeled to match construction document nomenclature,
- N. 27 1500 Telephone Data Systems
1. Coordinate with the District IT Department for more information regarding submittal requirements.
 2. Provide electronic submittals in Adobe PDF format within one file. Organize pages within submittal to be in the same order as the specification items (for example, racks prior to cabling). Where multiple submittals are provided due to submittal. If three or more reviews are required of the 27-1500 submittals, Contractor shall reimburse the Engineer for \$1,200 before the Engineer will commence the third review. rejections/corrections, upon completing the submittal process with "No Exceptions Taken", provide a consolidated single PDF submittal showing all products on the project.
 3. Provide proof of RCDD certification and connectivity manufacturer certification.
 4. Provide submittals for all racks/cabinets; patch panels, devices, cabling, firestopping solutions, tray, non-continuous cable support devices, grounding equipment, and miscellaneous equipment to be used on project. Where multiple part numbers are listed on a datasheet/cutsheet, highlight or circle applicable part.
 5. Provide submittals showing complete racking layout in plan and elevation view to scale. Coordinate exact rack layout with Owner Information Technology Representative prior to submittal.
 6. Provide color samples of all available standard color faceplates to architect.
 7. Provide proposed labeling scheme for approval by owner/engineer.

8. Provide catalog cutsheets of all test equipment that will be used.
 9. Provide results of all copper and fiber optic cable tests.
- O. 27 5123 Intercommunication Systems
1. The following items shall be included in the shop drawings submittal:
 - a. Project manager to provide written proof, signed and dated, that shop drawings and/or brochure has been checked for accuracy prior to submittal. Shop drawings to comply in all respects with the requirements of the contract drawings and specifications for this project.
 - b. Provide a complete bill of materials for all components, accessories and hardware to be provided in order to assemble a complete and working system as described within the contract documents.
 - c. Submit manufacturer's data and installation details for all devices, plates, cables and similar equipment. Product data showing multiple options, products and/or models shall be clearly marked identifying the specific options, products and/or models being provided.
 - d. Submit dimensioned drawings and device wiring layouts for intercom system.
 - e. Submit equipment rack elevation diagrams.
- P. 28 3111 Fire Alarm and Detection System
1. Submit manufacturer's data on fire alarm and detection systems including, but not limited to, roughing-in diagrams and instructions for installation, operating and maintenance, suitable for inclusion in maintenance manuals.
 2. Provide shop drawings showing equipment/device locations and connecting wiring of entire fire alarm and detection system. Include wiring diagrams and riser diagrams of panel. Provide dimensioned drawing of Fire Alarm Control Panel and Building Graphic. Shop drawings shall be prepared by an individual with a minimum NICET Level IV (Fire Protection Engineering/Fire Alarm Systems) certification. The individual's name and certification number shall be indicated on submittal design drawings.
 3. Submit a written statement to the Architect and the state and local Fire Marshal's Office that each device of the fire alarm system will be installed, inspected and tested in accordance with applicable requirements of NFPA Standard 72.
 4. A complete set of shop drawings indicating:
 - a. Location of all alarm-initiating and alarm-signaling devices.
 - b. Point-to-point wiring diagrams for all alarm-initiating and alarm-signaling devices.
 5. Wiring diagrams for:
 - a. Alarm control panels.
 - b. Auxiliary function relays and solenoids.
 - c. Remote signaling equipment.
 - d. Standby battery calculations, including voltage drop calculation.
 6. A complete equipment list identifying:

- a. Type
 - b. Model
 - c. Manufacturer
 - d. Manufacturer catalog data sheets
 - e. UL Listing and/or FM approval showing compatibility of device with Fire Alarm Control Panel (FACP)
7. A complete zone list identifying all:
- a. Alarm-initiating and alarm-signaling devices.
 - b. Remote signaling and auxiliary function zones.
 - c. Specific devices associated with each zone.
8. Submit to State and Local Fire Marshall, a complete Certificate of Compliance

1.4 OPERATION & MAINTENANCE MANUALS

- A. Provide operating instruction and maintenance data books for all equipment and materials furnished under this Division.
- B. Submit four copies of operating and maintenance data books for review at least four weeks before final review of the project. Assemble all data in a completely indexed volume or volumes and identify the size, model, and features indicated for each item. The binder (sized to the material) shall be a 2" slide lock unit (Wilson-Jones WLJ36544B). The cover shall be engraved with the job title in 1/2" high letters and the name and address of the Contractor in 1/4" high letters. Provide the same information in 1/8" letters on the spine.
- C. Include complete cleaning and servicing data compiled in clearly and easily understandable form. Show serial numbers of each piece of equipment, complete lists of replacement parts, motor ratings, etc. Each unit shall have its own individual sheet. (Example: If two items of equipment A and D appear on the same sheet, an individual sheet shall be provided for each unit specified).
- D. Include the following information where applicable.
 - 1. Identifying name and mark number.
 - 2. Certified outline Drawings and Shop Drawings.
 - 3. Parts lists.
 - 4. Performance curves and data.
 - 5. Wiring diagrams.
 - 6. Light fixture schedule with the lamps and ballast data used on the project for all fixtures
 - 7. Manufacturer's recommended operating and maintenance instructions.
 - 8. Vendor's name and address for each item.
- E. The engineer shall review the manuals and when approved, will forward the manuals on to the architect. If the manuals are rejected twice, the contractor shall reimburse the engineer the sum of \$1,200.00 for each review afterwards.
- F. Provide high quality video and audio recording for all training sessions. All trainings shall be recorded by utilizing a pro-grade digital camera system. Utilize camera tripod and record audio directly at the presenter. **Smartphone recordings are not allowed.**
- G. Provide Operation and Maintenance Manual information for each section listed below in addition to the general requirements listed above.
 - 1. 26 0526 Grounding

- a. Test Results of measured resistance values
2. 26 0548 Electrical Seismic Control
 - a. Certificate of Compliance from Final Inspection
3. 26 0923 Occupancy Sensors
 - a. Record Drawings
 - i. A complete set of 'as-builts' drawings showing installed wiring, specific interconnections between all equipment, and internal wiring of this equipment shall be included in the operating and maintenance manuals upon complete of the system.
 - ii. Provide a CD to the owner containing the information specified below. The CD shall include all information required to allow the Owner to change the schedules themselves. The CD shall contain a minimum of following:
 1. CAD drawing files of 'as-built' lighting control components and point to point connections.
 2. General configuration programming.
 3. Job specific configuration programming to include schedule.
 4. Tutorial file on complete programming of lighting control system.
4. 26 0943 Lighting Control Equipment
 - a. Record Drawings
 - i. A complete set of 'as-builts' drawings showing installed wiring, specific interconnections between all equipment, and internal wiring of this equipment shall be included in the operating and maintenance manuals upon complete of the system.
 - ii. Provide a CD to the owner containing the information specified below. The CD shall include all information required to allow the Owner to change the schedules themselves. The CD shall contain a minimum of following:
 1. CAD drawing files of 'as-built' lighting control components and point to point connections.
 2. General configuration programming.
 3. Job specific configuration programming to include schedule.
 4. Tutorial file on complete programming of lighting control system.
5. 26 2913 Motor Starters
 - a. After installation is complete, including water and air balancing, measure voltage (L-L and L-N) and full load current of each phase of each motor. Submit report showing field readings of voltage, amperage, service factor, and thermal heater size installed for each motor.

6. 27 1500 Telephone/Data System
 - a. Test Results as outlined in Section 27 1500
 - b. Manual shall include all service, installation, programming and warranty, including test results for each cable.
 - c. Provide laminated plans (minimum size 11 x 17) of all telecommunications record drawings (including riser diagrams) in each and every EF, ER and TR.
 - d. Record Drawings
 - i. The Owner shall provide electronic (DWG) format of telephone/data system drawings that as-built construction information can be added. These documents will be modified accordingly by the telecommunications contractor to denote as-built information as defined above and returned to the Owner.
 - ii. Provide a complete set of "as built" drawings in paper and electronic (DWG and PDF) formats showing cabinets, racks, patch panels, wiring, specific interconnections between all equipment and internal wiring of equipment within 30 working days of completion. Drawings are to include all labeling information used in denoting equipment used in the installation. Labeling, icons, and drawing conventions used shall be consistent throughout all documentation provided.
7. 28 3113 Fire Alarm and Detection System
 - a. Manual Requirements
 - i. Operating and maintenance manuals shall be submitted prior to testing of the system. Manuals shall include all service, installation, and programming information.
 - b. Record Drawings
 - i. A complete set of CAD "as-built" drawings showing installed wiring, color coding, specific interconnections between all equipment, and internal wiring of the equipment shall be delivered to the owner upon completion of the system. Vendor shall not request drawings from the Engineer. Vendor shall request current architectural drawings from the Architect and include all cost with bid.
 - ii. A building map shall be supplied to the owner indicating the exact location of all devices along with the addresses of the individual devices. Install building fire alarm map adjacent to the fire alarm panel and all remote operating panels. Provide high quality plastic sign (map holder) with two layers. The back layer shall be painted black. The front layer shall be a clear center for viewing the CAD fire alarm drawing. Edges of the sign shall be colored to match the building interior. The building map shall indicate the various devices and wiring by the use of different colors (minimum of five colors).
 - iii. Provide a CD to the Owner containing the information

specified below. The CD shall include all information required to allow the Owner to change the fire alarm program themselves. The CD shall contain a minimum of the following:

1. CAD drawing files of building fire alarm map.
2. CAD drawing files of as-built fire alarm components and point to point connections.
3. General configuration programming.
4. Job specific configuration programming.
5. Tutorial file on complete programming of fire alarm system

1.5 SPARE PARTS:

A. Provide spare parts (fuses, diffusers, lamps, etc.) as specified. Transmit all spare parts to Owner's Representative prior to substantial completion.

Section	Section Name	Description	Qty. Rqrd.	Qty Rcvd	Fulfilled?
26 0532	Conduit Raceway	Provide 500 feet of 3/4" conduit with 3 #12 conductors, 500 feet of 3/4" conduit with 3 #10 conductors, Provide all supports, fittings, boxes, terminations, etc. as required for installation. Install only as directed by engineer. Credit back all unused material and labor to Owner.	Per description		
26 2816	Motor and Circuit Disconnects	Spare fuses amounting to one spare fuse for each 10 installed but not less than three of any one type and size.	Per description		
26 2913	Motor Starters	Maintenance Stock Fuses: For types and ratings required, furnish additional fuses, amounting to one unit for every 10 installed, but not less than 5 units of each, for both power and control circuit fuses.	Per description		

END OF SECTION 260502

BLANK PAGE

SECTION 260507 - ELECTRICAL CONNECTIONS FOR EQUIPMENT**PART 1 - GENERAL****1.1 RELATED DOCUMENTS:**

- A. Drawings and general provisions of Contract, including General and Supplementary Conditions and Division-1 Specification sections, apply to work of this section.
- B. This section is a Division-26 Basic Materials and Methods section, and is part of each Division-23 section making reference to electrical connections.

1.2 DESCRIPTION OF WORK:

- A. Extent of electrical connection for equipment includes final electrical connection of all equipment having electrical requirements. Make final connections for all owner furnished equipment. See other applicable portions of specification for building temperature control wiring requirements.
- B. Refer to Division-23 sections for motor starters and controls furnished integrally with equipment; not work of this section.
- C. Refer to Division-23 section for control system wiring; not work of this section.
- D. Refer to sections of other Divisions for specific individual equipment power requirements.

1.3 QUALITY ASSURANCE:

- A. **NEC COMPLIANCE:** Comply with applicable portions of NEC as to type products used and installation of electrical power connections.
- B. **UL LABELS:** Provide electrical connection products and materials that have been UL-listed and labeled.

PART 2 - PRODUCTS**2.1 GENERAL:**

- A. For each electrical connection indicated, provide complete assembly of materials, including but not necessarily limited to, raceways, conductors, cords, cord caps, wiring devices, pressure connectors, terminals (lugs), electrical insulating tape, heat-shrinkable insulating tubing, cable ties, solderless wire nuts, and other items and accessories as needed to complete splices, terminations, and connections as required. Crimp on or slip-on type splicing materials (insulation displacement type) designed to be used without wire stripping are not acceptable. See Section 26 0532, Conduit Raceways; Section 26 2726 Wiring Devices; and Section 26 0519 Conductors and Cables for additional requirements. Provide final connections for equipment consistent with the following:
 - 1. Permanently installed fixed equipment - flexible seal-tite conduit from branch circuit terminal equipment, or raceway; to equipment, control cabinet, terminal junction box or wiring terminals. Totally enclose all wiring in raceway.
 - 2. Movable and/or portable equipment - wiring device, cord cap, and multi-conductor cord suitable for the equipment and in accordance with NEC requirements (Article 400).
 - 3. Other methods as required by the National Electrical Code and/or as required by special equipment or field conditions.

PART 3 - EXECUTION**3.1 INSTALLATION OF ELECTRICAL CONNECTIONS:**

- A. Make electrical connections in accordance with connector manufacturer's written instructions and with recognized industry practices, and complying with requirements of NEC and NECA's "Standard of Installation" to ensure that products fulfill requirements.
- B. Connect electrical power supply conductors to equipment conductors in accordance with equipment manufacturer's written instructions and wiring diagrams.
- C. Coordinate installation of electrical connections for equipment with equipment installation work.
- D. Verify all electrical loads (voltage, phase, horse power, full load amperes, number and point of connections, minimum circuit ampacity, etc.) for equipment furnished under other Divisions of this specification, by reviewing respective shop drawings furnished under each division. Meet with each subcontractor furnishing equipment requiring electrical service and review equipment electrical characteristics. Report any variances from electrical characteristics noted on the electrical drawings to Architect before proceeding with rough-work. In summary it is not in the Electrical Engineers scope to review the shop drawings from other trades/divisions.
- E. Interlock the exhaust fans of paint spray booths with the air spray equipment to prevent equipment from operating until exhaust fan is in operation.
- F. Obtain and review the equipment shop drawings to determine particular final connection requirements before rough-in begins for each equipment item.
- G. Refer to basic materials and methods Section 26 0553 Electrical Identification, Conductors, for identification of electrical power supply conductor terminations.

END OF SECTION 260507

SECTION 260519 - CONDUCTORS AND CABLES (600V AND BELOW)

PART 1 – GENERAL

1.1 RELATED DOCUMENTS:

- A. Drawings and general provisions of Contract, including General and Supplementary Conditions and Division-1 Specification sections, apply to work of this section.
- B. This section is a Division-26 Basic Materials and Methods section, and is part of each Division-26 section making reference to conductors and cables specified herein.

1.2 DESCRIPTION OF WORK:

- A. Extent of electrical conductor and electrical cable work is indicated by drawings and schedules.
- B. Types of conductors and cables in this section include the following:
 - 1. Copper Conductors (600V)
 - 2. 0-10V Class 1 Circuits
- C. Applications for conductors and cables required for project include:
 - 1. Feeders
 - 2. Branch Circuits
 - 3. 0-10V Class 1 Circuits

1.3 RECORDS SUBMITTAL: Refer to Section 26 0502 for requirements.

1.4 QUALITY ASSURANCE:

- A. Comply with NEC as applicable to construction and installation of electrical conductors and cable. Comply with UL standards and provide electrical conductors and cables that have been UL-listed and labeled.
- B. Comply with applicable portions of NEMA/Insulated Cable Engineers Association standards pertaining to materials, construction and testing of conductors and cable.
- C. Comply with applicable portions of ANSI/ASTM and IEEE standards pertaining to construction of conductors and cable.

1.5 SUBMITTALS: Refer to Section 26 0502 for requirements.

PART 2 - PRODUCTS

2.1 COPPER AND ALUMINUM CONDUCTORS (600V):

- A. Provide factory-fabricated conductors of sizes, ratings, materials, and types indicated for each service. Where not indicated provide proper selection to comply with project's installation requirements and NEC standards. Provide conductors in accordance with the following:
 - 1. Distribution and Panelboard Feeders; and Other Conductors, #2 AWG and Larger – [Copper] [Aluminum] conductor; see drawings for insulation type.

2. Branch Circuit Conductors and All Conductors #3 AWG and Smaller - Copper conductor, with THHN/THWN insulation. Size all conductors in accordance with NEC; minimum size to be #12 AWG.
- B. Provide a maximum of three phase conductors in any one conduit or as approved by electrical engineer. Where phase conductors share a common neutral they must have a means to simultaneously disconnect all ungrounded conductors at the point where the branch circuits originate. The ungrounded and neutral conductors of a multi-wire branch circuit must be grouped together by wire ties at the point of origination.
 - C. Provide neutral and ground wire as specified elsewhere in documents.
 - D. Provide separate neutral conductor for all single phase branch circuits installed. No shared neutrals are allowed. Neutral conductor shall be the same size as the phase conductor.
 - E. Applicable to Existing Circuits Which are Modified As a Result of the Project: Where phase conductors share a common neutral they must have a means to simultaneously disconnect all ungrounded conductors at the point where the branch circuits originate. The ungrounded and neutral conductors of a multi-wire branch circuit must be grouped together by wire ties at the point of origination.
 - F. Applicable to New Circuits As a Result of the Project: Provide a maximum of three phase conductors in any one conduit or as approved by electrical engineer. Provide separate neutral conductor for all single phase branch circuits installed. No shared neutrals are allowed. Neutral conductor shall be the same size as the phase conductor.

2.2 COPPER LOW VOLTAGE CONDUCTORS (0-10V CIRCUITS):

- A. 0-10V Class 1 Circuits:
 1. General:
 - a. Provide Class 1 circuits for all 0-10V dimming installations. Class 1 circuits shall be permitted to be installed with other circuits as specified in NEC 725.48 (A) and (B):
 - i. Class 1 circuits shall be permitted to occupy the same cable, cable tray, enclosure, or raceway without regard to whether the individual circuits are alternating or direct current, provided all conductors are insulated for the maximum voltage of any conductors in the cable, cable tray, enclosure or raceway.
 - ii. Class 1 circuits shall be permitted to be installed with power supply conductors as specified:
 1. Class 1 and power supply circuits shall be permitted to occupy the same cable, enclosure, or raceway only when functionally associated.
 - iii. Utilize purple and grey copper conductors, with THHN/THWN insulation.

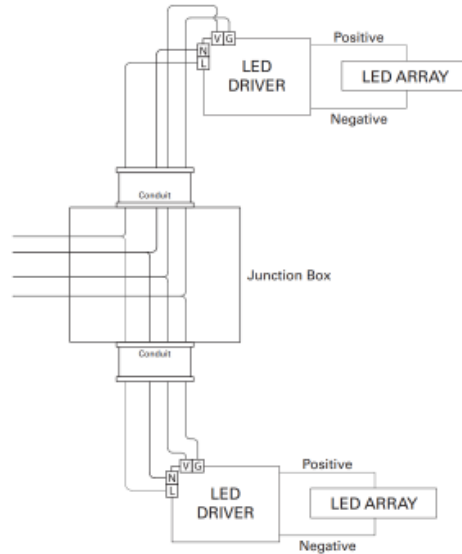

PART 3 - EXECUTION

3.1 INSTALLATION:

- A. General: Install electric conductors and cables as indicated, in compliance with manufacturer's written instructions, applicable requirements of NEC and NECA's "Standards of Installation", and in accordance with recognized industry practices.
- B. Coordinate installation work with electrical raceway and equipment installation work, as necessary for proper interface.
- C. Cables may be pulled by direct attachment to conductors or by use of basket weave pulling grip applied over cables. Attachment to pulling device shall be made through approved swivel connection. Nonmetallic jacketed cables of small size may be pulled directly by conductors by forming them into a loop that pull wires can be attached; remove insulation from conductors before forming the loop. Larger sizes of cable may be pulled by using basket weave pulling grip, provided the pulling force does not exceed limits recommended by manufacturer; if pulling more than one cable, bind them together with friction tape before applying the grip. For long pulls requiring heavy pulling force, use pulling eyes attached to conductors.
- D. Do not exceed manufacturer's recommendations for maximum allowable pulling tension, side wall pressure, and minimum allowable bending radius. In all cases, pulling tension applied to the conductors shall be limited to 0.008 lbs. per circular mil of conductor cross-section area.
- E. Pull in cable from the end having the sharpest bend; i.e. bend shall be closest to reel. Keep pulling tension to minimum by liberal use of lubricant, and turning of reel, and slack feeding of cable into duct entrance. Employ not less than one man at reel and one in pullhole during this operation.
- F. For training of cables, minimum bend radius to inner surface of cable shall be 12 times cable diameter.
- G. Where cable is pulled under tension over sheaves, conduit bends, or other curved surfaces, make minimum bend radius 50% greater than specified above for training.
- H. Use only wire and cable pulling compound recommended by the specific cable manufacturer, and that is listed by UL.
- I. Seal all cable ends unless splicing is to be done immediately. Conduit bodies shall not

contain splices.

J. Follow manufacturer's instructions for splicing and cable terminations.

3.2 AFTER INSTALLATION TEST FOR CABLE 600 VOLTS AND BELOW:

A. Prior to energization, test cable and wire for continuity of circuitry, and for short circuits, Megger all circuits of 100 amp and greater rating. Correct malfunctions. Record all test data and provide written test report.

B. Subsequent to wire and cable connections, energize circuitry and demonstrate functioning in accordance with requirements.

3.3 IDENTIFICATION OF FEEDERS: Refer to Section 26 0552 for requirements.

END OF SECTION 260519

SECTION 260526 - GROUNDING**PART 1 – GENERAL****1.1 RELATED DOCUMENTS**

- A. Drawings and general provisions of Contract, including General and Supplementary Conditions and Division-1 Specification sections, apply to work of this section.
- B. Division-26 Basic Materials and Methods sections apply to work specified in this section.

1.2 DESCRIPTION OF WORK:

- A. Provide grounding as specified herein, and as indicated on drawings.
- B. Provide grounding and bonding of all electrical and communication apparatus, machinery, appliances, building components, and items required by the NEC to provide a permanent, continuous, low impedance, grounding system.
- C. Unless otherwise indicated, ground the complete electrical installation including the system neutral, metallic conduits and raceways, boxes, fittings, devices, cabinets, and equipment in accordance with all code requirements.
- D. Ground each separately derived system, as described in NEC Section 250-30, unless otherwise indicated.
- E. Types of grounding in this section include the following:
 - 1. Grounding Electrodes
 - 2. Enclosures
 - 3. Systems
 - 4. Equipment
 - 5. Other items indicated on drawings
- F. Requirements of this section apply to electrical grounding work specified elsewhere in these specifications.

1.3 QUALITY ASSURANCE:

- A. Comply with NEC as applicable to electrical grounding and ground fault protection systems. Comply with applicable ANSI and IEEE requirements. Provide products that have been UL listed and labeled.
- B. Resistance from the service entrance ground bus, through the grounding electrode to earth, shall not exceed 5 ohms.

1.4 SUBMITTALS: Refer to Section 26 0503 for requirements.**PART 2 – PRODUCTS****2.1 MATERIALS AND COMPONENTS:**

- A. GENERAL: Except as otherwise indicated, provide each electrical grounding system as specified herein, and as shown on drawings, including but not necessarily limited to, cables/wires, connectors, terminals (solderless lugs), grounding rods/electrodes and plate electrodes, bonding jumper braid, and other items and accessories needed for

complete installation. Where materials or components are not otherwise indicated, comply with NEC, NEMA and established industry standards for applications indicated.

- B. ELECTRICAL GROUNDING CONDUCTORS: Unless otherwise indicated, provide electrical grounding conductors for grounding connections matching power supply wiring materials and sized according to NEC. Provide with green insulation.
- C. GROUND RODS: Steel with copper welded exterior, 3/4" dia. x 10' long. Weaver or Cadweld.
- D. INSULATED GROUNDING BUSHINGS: Plated malleable iron body with 150 degree Centigrade molded plastic insulating throat, lay-in grounding lug with hardened stainless steel fasteners, OZ-Gedney BLG, or Thomas & Betts #TIGB series.
- E. CONNECTIONS TO PIPE: For cable to pipe, OZ-Gedney G-100B series or Thomas & Betts #390X series, or Burndy type GAR.
- F. CONNECTIONS TO STRUCTURAL STEEL, GROUND RODS, OR SPLICES: For splicing and/or connecting conductors, use exothermic welds or high pressure compression type connectors. Provide exothermic weld kits manufactured by Cadweld or Thermoweld. If high compression type connectors are used for cable-to-cable, or cable-to-steel, or cable-to-ground rod connections, provide Thomas & Betts #53000 series, or Burndy Hyground series.
- G. BONDING JUMPERS: OZ-Gedney Type BJ, or Thomas & Betts #3840 series, or Burndy type GG and type B braid.

PART 3 - EXECUTION

3.1 INSTALLATION OF GROUNDING SYSTEMS:

- A. Install electrical grounding systems in accordance with manufacturer's written instructions and with recognized industry practices to ensure grounding devices comply with requirements.
- B. Install clamp-on connectors only on thoroughly cleaned and metal contact surfaces, to ensure electrical conductivity and circuit integrity.
- C. Provide grounding for the entire raceway, enclosure, equipment and device system in accordance with NEC. All non-metallic raceways shall include copper grounding conductor sized in accordance with NEC. Include copper grounding conductor in all raceway installed in suspended slabs.
- D. Provide grounding conductors for dimming systems in accordance with manufacturer's requirement.

3.2 GROUNDING ELECTRODES:

- A. GROUNDING ELECTRODE CONDUCTOR: Provide grounding electrode conductor sized per NEC table 250-94 or as indicated.
- B. Run main grounding conductors exposed or in metallic conduit if protection or concealment is required.
- C. EQUIPMENT BONDING/GROUNDING: Provide a NEC sized conductor, whether indicated or not on the drawings, in raceways as follows:
 1. Non-metallic conduits and ducts.
 2. Distribution feeders.
 3. Motor and equipment branch circuits.
 4. Device and lighting branch circuits.

5. Provide grounding bushings and bonding jumpers for all conduit terminating in reducing washers, concentric, eccentric or oversized knockouts at panelboards, cabinets and gutters.
- D. Provide bonding jumpers across expansion and deflection couplings in conduit runs, across pipe connections at water meters, and across dielectric couplings in metallic cold water piping system.
- E. Provide bonding wire in all flexible conduit.

END OF SECTION 260526

BLANK PAGE

SECTION 260529 - SUPPORTING DEVICES**PART 1 – GENERAL****1.1 RELATED DOCUMENTS:**

- A. Drawings and general provisions of Contract, including General and Supplementary Conditions and Division-1 Specification section, apply to work of this section.
- B. This section is a Division-26 Basic Materials and Methods section, and is a part of each Division-26, 27 and 28 section making reference to supports, anchors, sleeves, and seals, specified herein.

1.2 DESCRIPTION OF WORK:

- A. Extent of supports, anchors, and sleeves is indicated by drawings and schedules and/or specified in other Division-26 sections. See Section 260532, Raceways, for additional requirements.
- B. Work of this section includes supports, anchors, sleeves and seals required for a complete raceway support system, including but not limited to: clevis hangers, riser clamps, C-clamps, beam clamps, one and two hole conduit straps, offset conduit clamps, expansion anchors, toggle bolts, threaded rods, U-channel strut systems, threaded rods and all associated accessories.

1.3 QUALITY ASSURANCE:

- A. Comply with NEC as applicable to construction and installation of electrical supporting devices. Comply with applicable requirements of ANSI/NEMA Std. Pub No. FB 1, "Fittings and Supports for Conduit and Cable Assemblies". Provide electrical components that are UL-listed and labeled.

PART 2 - PRODUCTS**2.1 MANUFACTURED SUPPORTING DEVICES:****A. GENERAL:**

- 1. Provide supporting devices; complying with manufacturer's standard materials, design and construction in accordance with published product information, and as required for a complete installation; and as herein specified. See drawings for additional requirements.

PART 3 - EXECUTION**3.1 INSTALLATION OF SUPPORTING DEVICES:**

- A. Install hangers, anchors, sleeves, and seals as required, in accordance with manufacturer's written instructions and with recognized industry practices to ensure supporting devices comply with requirements. Comply with requirements of NECA, NEC and ANSI/NEMA for installation of supporting devices.
- B. Coordinate with other electrical work, including raceway and wiring work, as necessary to interface installation of supporting devices with other work.
- C. Install hangers, supports, clamps and attachments to support piping properly from

building structures. Arrange for grouping of parallel runs of horizontal conduits to be supported together on trapeze type hangers where possible. For pre-and post tensioned construction, use pre-set inserts for support of all electrical work. Do not use toggle bolts, moly bolts, wood plugs or screws in sheetrock or plaster as support for any equipment or raceway.

D. RACEWAYS:

1. Support raceways that are rigidly attached to structure at intervals not to exceed 8 feet on center, minimum of two straps per 10 foot length of raceway, and within 12" of each junction box, coupling, outlet or fitting. Support raceway at each 90° degree bend. Support raceway (as it is installed) in accordance with the following:

<u>NUMBER OF RUNS</u>	<u>3/4" TO 1-1/4" Ø</u>	<u>1-1/2" & LARGER Ø</u>
1	Full straps, clamps or hangers.	Hanger
2	Full straps, clamps or hangers.	Mounting Channel
3 or more	Mounting Channel	Mounting Channel

2. Support suspended raceways on trapeze hanger systems; or individually by means of threaded rod and straps, clamps, or hangers suitable for the application. Do not use "tie wire" as a portion of any raceway support system; do not support raceway from ceiling support wires.

E. WIREWAYS, BUS DUCTS AND CABLE TRAYS:

1. Provide vertical and lateral support systems for all wireways, busway, and cable trays that are supported from overhead structure. See Sections 260536 and 262500 for additional requirements.

END OF SECTION 260529

SECTION 260532 - CONDUIT RACEWAY**PART 1 – GENERAL****1.1 RELATED DOCUMENTS:**

- A. Drawings and general provisions of Contract, including General and Supplementary Conditions and Division 1 Specification sections, apply to work of this section.
- B. This section is a Division-26 Basic Materials and Methods section, and is part of each Division-26 section making reference to electrical raceways and specified herein.

1.2 DESCRIPTION OF WORK:

- A. Extent of raceways is indicated by drawings and schedules.
- B. Types of raceways in this section include the following:
 - 1. Electrical Metallic Tubing
 - 2. Flexible Metal Conduit
 - 3. Intermediate Metal Conduit
 - 4. Liquid-tight Flexible Metal Conduit
 - 5. Rigid Metal Conduit
 - 6. Rigid Non-metallic Conduit

1.3 QUALITY ASSURANCE:

- A. **MANUFACTURERS:** Firms regularly engaged in manufacture of raceway systems of types and sizes required, whose products have been in satisfactory use in similar service for not less than three (3) years.
- B. **STANDARDS:** Comply with applicable portions of NEMA standards pertaining to raceways. Comply with applicable portions of UL safety standards pertaining to electrical raceway systems; and provide products and components that have been UL-listed and labeled. Comply with NEC requirements as applicable to construction and installation of raceway systems.
- C. **SUBMITTALS:** Refer to Section 26 0502 for requirements.

PART 2 – PRODUCTS**2.1 METAL CONDUIT AND TUBING:**

- A. **GENERAL:**
 - 1. Provide metal conduit, tubing and fittings of types, grades, sizes and weights (wall thicknesses) as indicated; with minimum trade size of 3/4".
- B. **RIGID METAL CONDUIT (RMC):** FS WW-C-0581 and ANSI C80.1.
- C. **INTERMEDIATE STEEL CONDUIT (IMC):** FS WW-C-581.
- D. **PVC EXTERNALLY COATED RIGID STEEL CONDUIT:** ANSI C80.1 and NEMA Std. Pub. No. RN 1.
- E. **ALUMINUM CONDUIT:** Not acceptable.
- F. **ELECTRICAL NON-METALLIC TUBING (ENT) SYSTEM:** Not acceptable.

- G. MC CABLE: Not acceptable, except for the following:
 - 1. The use of MC-PCS cable is acceptable for light fixture whips utilizing 0-10v control schemes, not longer than 72" in length, located above removable grid ceilings. All MC cable shall be provided with anti-short fittings.
 - a. Acceptable Manufacturers
 - i. AFC – MC Luminary Cable
 - ii. Encore – MC-LED Lighting Cable
 - iii. Southwire – MC-PCS Duo
 - H. RIGID AND INTERMEDIATE STEEL CONDUIT FITTINGS:
 - 1. Provide fully threaded malleable steel couplings; raintight and concrete tight where required by application. Provide double locknuts and metal bushings at all conduit terminations. Install OZ Type B bushings on conduits 1-1/4" and larger.
 - I. ELECTRICAL METALLIC TUBING (EMT): FS WW-C-563 and ANSI C80.3.
 - J. EMT FITTINGS:
 - 1. Provide insulated throat nylon bushings with non-indenter type malleable steel fittings at all conduit terminations. Install OZ Type B bushings on conduits 1" larger. Cast or indenter type fittings are not acceptable.
 - K. FLEXIBLE METAL CONDUIT: FS WW-C-566, of the following type;
 - 1. Zinc-coated steel.
 - L. FLEXIBLE METAL CONDUIT FITTINGS: FS W-F-406, Type 1, Class 1, and Style A.
 - M. LIQUID TIGHT FLEXIBLE METAL CONDUIT:
 - 1. Provide liquid-tight, flexible metal conduit; constructed of single strip, flexible continuous, interlocked, and double-wrapped steel; galvanized inside and outside; coated with liquid-tight jacket of flexible polyvinyl chloride (PVC).
 - N. LIQUID-TIGHT FLEXIBLE METAL CONDUIT FITTINGS: FS W-F-406, Type 1, Class 3, Style G.
 - O. EXPANSION FITTINGS: OZ Type AX, or equivalent to suit application.
- 2.2 NON-METALLIC CONDUIT AND DUCTS:
- A. GENERAL:
 - 1. Provide non-metallic conduit, ducts and fittings of types, sizes and weights as indicated; with minimum trade size of 3/4".
 - B. UNDERGROUND PVC PLASTIC UTILITIES DUCT:
 - 1. Minimum requirements shall be schedule 40 for encased burial in concrete and for Type II for direct burial.
 - C. PVC AND ABS PLASTIC UTILITIES DUCT FITTINGS:
 - D. ANSI/NEMA TC 9, match to duct type and material.
 - E. HDPE CONDUIT: Not acceptable.
- 2.3 CONDUIT; TUBING; AND DUCT ACCESSORIES:
- A. Provide conduit, tubing and duct accessories of types and sizes, and materials, complying with manufacturer's published product information, that mate and match conduit and tubing. Provide manufactured spacers in all duct bank runs.

2.4 SEALING BUSHINGS:

- A. Provide OZ Type FSK, WSK, or CSMI as required by application. Provide OZ type CSB internal sealing bushings.

2.5 CABLE SUPPORTS:

- A. Provide OZ cable supports for vertical risers, type as required by application.

PART 3 - EXECUTION**3.1 INSTALLATION OF ELECTRICAL RACEWAYS:**

- A. Install electrical raceways where indicated; in accordance with manufacturer's written instructions, applicable requirements of NEC and NECA "Standard of Installation", and in accordance with the following:
1. FEEDERS UNDER 600 VOLTS:
 - a. Install in electric metallic tubing (EMT). Below concrete slab-on-grade or in earth fill, install in non-metallic plastic conduit. In areas exposed to weather, moisture, or physical damage, install in RMC or IMC. In suspended slabs, install in EMT (NOT APPROVED). Encase non-metallic conduit 40-amps or more, 1-1/4" and larger and communication/data conduits 2" and larger in concrete. See duct banks.
 2. BRANCH CIRCUITS, SIGNAL AND CONTROL CIRCUITS, AND INDIVIDUAL EQUIPMENT CIRCUITS RATED LESS THAN 100 AMPS:
 - a. Install in electric metallic tubing (EMT). Below concrete slab-on-grade or in earth fill, install in non-metallic plastic duct. In areas exposed to weather, moisture, or physical damage, install in RMC or IMC. In suspended slabs, install in EMT (NOT APPROVED). Encase non-metallic conduit 40-amps or more, 1-1/4" and larger and communication/data conduits 2" and larger in concrete. See duct banks.
- B. Coordinate with other work including metal and concrete deck work, as necessary to interface installation of electrical raceways and components.
- C. Install raceway in accordance with the following:
1. Provide a minimum of 12" clearance measured from outside of insulation from flues, steam and hot water piping, etc. Avoid installing raceways in immediate vicinity of boilers and similar heat emitting equipment. Conceal raceways in finished walls, ceilings and floor (other than slab-on-grade), except in mechanical, electrical and/or communication rooms, conceal all conduit and connections to motors, equipment, and surface mounted cabinets unless exposed work is indicated on the drawings. Run concealed conduits in as direct a line as possible with gradual bends. Where conduit is exposed in mechanical spaces, etc., install parallel with or at right angles to building or room structural lines. Do not install lighting raceway until piping and duct work locations have been determined in order to avoid fixtures being obstructed by overhead equipment.
 2. Where cutting raceway is necessary, remove all inside and outside burrs; make cuts smooth and square with raceway. Paint all field threads (or portions of raceway where corrosion protection has been damaged) with primer and enamel finish coat to match adjacent raceway surface.
 3. Provide a minimum of 1 1/2" from nearest surface of the roof decking to raceway.
 4. Provide a maximum of three phase conductors in any one conduit or as approved by electrical engineer. Where phase conductors share a common

neutral they must have a means to simultaneously disconnect all ungrounded conductors at the point where the branch circuits originate. The ungrounded and neutral conductors of a multi-wire branch circuit must be grouped together by wire ties at the point of origination.

5. Provide neutral and ground wire as specified elsewhere in documents.
 6. Provide separate neutral conductor for all single phase branch circuits installed. No shared neutrals are allowed. Neutral conductor shall be the same size as the phase conductor.
- D. Comply with NEC for requirements for installation of pull boxes in long runs.
- E. Cap open ends of conduits and protect other raceways as required against accumulation of dirt and debris. Pull a mandrel and swab through all conduit before installing conductors. Install a 200 lb. nylon pull cord in each empty conduit run.
- F. Replace all crushed, wrinkled or deformed raceway before installing conductors.
- G. Do not use flame type devices as a heat application to bend PVC conduit. Use a heating device that supplies uniform heat over the entire area without scorching the conduit.
- H. Provide rigid metal conduit (RMC) for all bends greater than 22 degrees in buried conduit. Provide protective coating for RMC bend as specified herein.
- I. Where raceways penetrate building, area ways, manholes or vault walls and floors below grade, install rigid metal conduit (RMC) for a minimum distance of 10 feet on the exterior side of the floor or wall measured from interior face. Provide OZ, Type FSK, WSK or CSMI sealing bushings (with external membrane clamps as applicable) for all conduit penetrations entering walls or slabs below grade. Provide segmented type CSB internal sealing bushings in all raceways penetrating building walls and slabs below grade, and in all above grade raceway penetrations susceptible to moisture migration into building through raceway.
- J. Install liquid-tight flexible conduit for connection of motors, transformers, and other electrical equipment where subject to movement and vibration.
- K. Install spare 3/4" conduits (capped) from each branch panelboard into the ceiling and floor space. Run five into the ceiling space and five into the floor space. Where the floor is not accessible run six conduits into the ceiling space. Run conduits the required distance necessary to reach accessible ceiling space.
- L. Provide OZ expansion fittings on all conduits crossing building expansion joints, both in slab and suspended.
- M. Provide OZ cable supports in all vertical risers in accordance with NEC 300-19; type as required by application.
- N. Complete installation of electrical raceways before starting installation of cables/conductors within raceways.
- O. Raceway installation below grade:
1. Apply protective coating to metallic raceways in direct contact with earth or fill of any type; consisting of spirally wrapped PVC tape (1/2" minimum overlap of scotch wrap tape or equal); or factory applied vinyl cladding (minimum thickness .020 inches). Completely wrap and tape all field joints.
 2. Burial depths must comply with NEC Section 300-5 but in no case be less than 24", unless noted otherwise on drawings.
- P. Electrical Identification: Refer to Section 260553 for requirements.
- Q. SPARE PARTS: Refer to Section 26 0502 for requirements.

END OF SECTION 260532

SECTION 260533 - ELECTRICAL BOXES AND FITTINGS**PART 1 – GENERAL****1.1 RELATED DOCUMENTS:**

- A. Drawings and general provisions of Contract, including General and Supplementary Conditions and Division-1 Specifications sections, apply to work of this section.
- B. This section is a Division-26 Basic Materials and Methods section, and is a part of each Division-26, 27 and 28 section making reference to electrical wiring boxes and fittings specified herein. See Section 260532, Raceways, for additional requirements.

1.2 DESCRIPTION OF WORK:

- A. The extent of electrical box and electrical fitting work is indicated by drawings and schedules.
- B. Types of electrical boxes and fittings in this section include the following:
 - 1. Outlet Boxes
 - 2. Junction Boxes
 - 3. Pull Boxes
 - 4. Floor Boxes
 - 5. Conduit Bodies
 - 6. Bushings
 - 7. Locknuts
 - 8. Knockout Closures
 - 9. Miscellaneous Boxes and Fittings

1.3 QUALITY ASSURANCE:

- A. Comply with NEC as applicable to construction and installation of electrical boxes and fittings. Comply with ANSI C 134,1 (NEMA Standards Pub No. OS 1) as applicable to sheet-steel outlet boxes, device boxes, covers and box supports. Provide electrical boxes and fittings that have been UL-listed and labeled.

1.4 SUBMITTALS: Refer to Section 26 0502 for requirements.**PART 2 - PRODUCTS****2.1 FABRICATED MATERIALS:****A. INTERIOR OUTLET BOXES:**

- 1. Provide one piece, galvanized flat rolled sheet steel interior outlet wiring boxes with accessory rings, of types, shapes and sizes, including box depths, to suit each respective location and installation, construct with stamped knockouts in back and sides, and with threaded screw holes with corrosion-resistant screws for securing box and covers and wiring devices; minimum size 4"x4"x2-1/8".
- 2. Provide an 'FS' box, with no knockouts when surface mounted in a finished, non-utility space. Surface mounting is only acceptable when approved by the Architect.

- B. INTERIOR OUTLET BOX ACCESSORIES:
 - 1. Provide outlet box accessories as required for each installation, including mounting brackets, hangers, extension rings, fixture studs, cable clamps and metal straps for supporting outlet boxes, that are compatible with outlet boxes being used and fulfilling requirements of individual wiring applications.
- C. WEATHERPROOF OUTLET BOXES:
 - 1. Provide corrosion-resistant cast-metal weatherproof outlet wiring boxes, of types, shapes and sizes (including depth) required, with threaded conduit ends, cast-metal face plates with spring-hinged waterproof caps suitably configured for each application, with face plate gaskets and corrosion-resistant fasteners.
- D. JUNCTION AND PULL BOXES:
 - 1. Provide code-gage sheet steel junction and pull boxes, with screw-on covers; of types, shapes and sizes to suit each respective location and installation; with welded seams and equipped with stainless steel nuts, bolts, screws and washers.
- E. CONDUIT BODIES:
 - 1. Provide galvanized cast-metal conduit bodies, of types, shapes and sizes to suit respective locations and installation, construct with threaded-conduit-entrance ends, removable covers, and corrosion-resistant screws.
- F. BUSHINGS, KNOCKOUT CLOSURES AND LOCKNUTS:
 - 1. Provide corrosion-resistant punched-steel box knockout closures, conduit locknuts and malleable steel conduit bushings and offset connectors, of types and sizes to suit respective uses and installation.

PART 3 - EXECUTION

3.1 INSTALLATION OF ELECTRICAL BOXES AND FITTINGS:

- A. GENERAL:
 - 1. Install electrical boxes and fittings where indicated, complying with manufacturer's written instructions, applicable requirements of NEC and NECA's "Standard of Installation", and in compliance with recognized industry practices to ensure that products fulfill requirements.
 - 2. Coordinate installation of electrical boxes and fittings with wire/cable and raceway installation work.
 - 3. Provide coverplates for all boxes. See Section 262726, Wiring Devices.
 - 4. Provide weatherproof outlets for interior and exterior locations exposed to weather or moisture.
 - 5. Provide knockout closures to cap unused knockout holes where blanks have been removed.
 - 6. Install boxes and conduit bodies to ensure ready accessibility of electrical wiring. Do not install boxes above ducts or behind equipment. Install recessed boxes with face of box or ring flush with adjacent surface. Seal between switch, receptacle and other outlet box openings and adjacent surfaces with plaster, grout, or similar suitable material.
 - 7. Fasten boxes rigidly to substrates or structural surfaces, or solidly embed electrical boxes in concrete or masonry. Use bar hangers for stud construction. Use of nails for securing boxes is prohibited. Set boxes on opposite sides of common wall with minimum 10" of conduit between them. Set boxes on opposite sides of fire resistant walls with minimum of 24" separation.

8. Provide a minimum of 1 ½" from the nearest surface of the roof decking to the installed boxes.
9. Provide electrical connections for installed boxes.

END OF SECTION 260533

BLANK PAGE

SECTION 260553 - ELECTRICAL IDENTIFICATION**PART 1 - GENERAL****1.1 RELATED DOCUMENTS:**

- A. Drawings and general provisions of Contract, including General and Supplementary Conditions and Division-1 Specification sections, apply to work of this section.
- B. Requirements of the following Division 26 Sections apply to this section:
 - 1. "Basic Electrical Requirements".
 - 2. "Basic Electrical Materials and Methods".

1.2 SUMMARY

- A. This section includes identification of electrical materials, equipment and installations. It includes requirements for electrical identification components including but not limited to the following:
 - 1. Buried electrical line warnings.
 - 2. Identification labels for raceways, cables and conductors.
 - 3. Operational instruction signs.
 - 4. Warning and caution signs.
 - 5. Equipment labels and signs.
 - 6. Arc-flash hazard labels
- B. Related Sections: The following sections contain requirements that relate to this section:
- C. Division 9 Section "Painting" for related identification requirements.
- D. Refer to other Division 26 sections for additional specific electrical identification associated with specific items.

1.3 QUALITY ASSURANCE

- A. Electrical Component Standard: Components and installation shall comply with NFPA 70 "National Electrical Code"

1.4 SUBMITTALS: Refer to Section 26 0503 for requirements.**PART 2 – PRODUCTS****2.1 MANUFACTURERS**

- A. Manufacturers: Subject to compliance with requirements, provide products by the following:
 - 1. American Labelmark Co.
 - 2. Calpico, Inc.
 - 3. Cole-Flex Corp.
 - 4. Emed Co., Inc.
 - 5. George-Ingraham Corp.
 - 6. Ideal Industries, Inc.

7. Kraftbilt
8. LEM Products, Inc.
9. Markal Corp
10. National Band and Tag Co.
11. Panduit Corp.
12. Radar Engineers Div., EPIC Corp.
13. Seton Name Plate Co.
14. Standard Signs, Inc.
15. W.H Brady, Co.

2.2 ELECTRICAL IDENTIFICATION PRODUCTS

- A. Colored Conduit Systems for raceway identification:
 1. Factory-painted conduit and/or factory-painted couplings and fittings
- B. Colored paint for raceway identification:
 1. Use [Kwal Paint](#) colors as specified in Part 3 – Execution.
- C. Color Adhesive Marking Tape for Raceways, Wires and Cables:
 1. Self-adhesive vinyl tape not less than 3 mills thick by 1" to 2" in width.
- D. Underground Line Detectable Marking Tape:
 1. Permanent, bright colored, continuous-printed, acid- and alkali-resistant plastic tape specifically compounded for direct-burial service. Not less than 6" wide by 4 mills thick.
 2. With metallic core encased in a protective jacket for corrosion protection, detectable by metal detector when tape is buried up to 30 inches deep.
 3. Printed legend indicative of general type of underground line below.
- E. Wire/Cable Designation Tape Markers:
 1. Vinyl or vinyl-cloth, self-adhesive, wraparound, cable/conductor markers with pre-printed numbers and letters.
- F. Brass or Aluminum Tags:
 1. Metal tags with stamped legend, punched for fastener.
 2. Dimensions: 2" X 2" 19 gage.
- G. Engraved, Plastic Laminated Labels, Signs and Instruction Plates:
 1. Engraving stock plastic laminate, 1/16" minimum thickness for signs up to 20 sq. in. or 8" in length; 1/8 " thick for larger sizes. Engraved legend in 1/4" high white letters on black face and punched for mechanical fasteners.
- H. Arc-flash Hazard Labels:
 1. ANSI Z535.4 Safety Label.
 2. Adhesive backed polyester with self-laminating flap. Chemical, abrasion and heat resistant.
 3. Dimensions: 5" x 3.5"
 4. Information contained: Arc-flash boundary; Voltage; Flash Hazard Category; Incident Energy (arc rating); checkboxes for the required Personal Protective Equipment (PPE) and the date that the calculations were performed.
- I. Equipment Labels:

1. Adhesive backed polyester with self-laminating flap. Chemical, abrasion and heat resistant.
 2. Dimensions: minimum 5" x 2"
 3. Conductor-Identification-Means Labels:
 - a. Information contained: the method utilized for identifying ungrounded conductors within switchboards, distribution panels and branch circuit panels.
 4. Available-Fault-Current Labels:
 - a. Information contained: maximum available fault current at the respective piece of equipment, and date of calculation of fault current.
 5. Source-of-Supply Labels:
 - a. Information contained: indicate the device or equipment where the power supply originates.
- J. Baked Enamel Warning and Caution Signs for Interior Use:
1. Preprinted aluminum signs, punched for fasteners, with colors legend and size appropriate to location.
- K. Fasteners for Plastic-Laminated and Metal Signs:
1. Self-tapping stainless steel screws or # 10/32 stainless steel machine screws with nuts, flat and lock washers.
- L. Cable Ties:
1. Fungus-inert, self-extinguishing, one-piece, self-locking nylon cable ties, 0.18" minimum width, 50-lb. Minimum tensile strength, and suitable for a temperature range from minus 40° F. to 185° F. Provide ties for specified colors when used for color coding.
- M. Colored Support Wires:
1. When electrical equipment/wiring is supported by wires within the ceiling cavity, these wires shall be independent of the ceiling support assembly and shall be distinguishable by painting entire length in bright yellow.

PART 3 – EXECUTION

3.1 INSTALLATION

- A. Lettering and Graphics:
1. Coordinate names, abbreviations, colors and other designations used in electrical identification work with corresponding designations specified or indicated. Install numbers, lettering and colors as approved in submittals and as required by code.
- B. Install identification devices in accordance with manufacturer's written instructions and requirements of NEC.
- C. Sequence of Work:
1. Where identification is to be applied to surfaces that require a finish, install identification after completion of finish work.
- D. Conduit Identification:
1. Identify Raceways of Certain Systems with Color Coding. Acceptable means of color identification are as follows:
 - a. Factory-painted conduit.

- b. Band exposed or accessible raceways of the following systems for identification. Bands shall be pre-tensioned, snap-around colored plastic sleeves, colored adhesive marking tape, or a combination of the two. Make each color band 2 inches wide, completely encircling conduit, and place adjacent bands of two-color markings in contact, side by side. Install bands at changes in direction, at penetrations of walls and floors, and at 40-foot maximum intervals in straight runs. Apply the following colors:
 - i. Fire Alarm System: Red
 - ii. Sound/IC: Blue
 - iii. Data: Green
 - iv. MATV: Black
 - v. Security: Orange
 - vi. Legally Required Emergency Systems: Red with Black Stripe (Per NEC 700.10(A))

2. Identify Junction, Pull and Connection Boxes.

- a. Code-required caution sign for boxes shall be pressured-sensitive, self-adhesive label indication system voltage in black, preprinted on orange background. Install on outside of box cover. Also label box covers on outside of cover with identity of contained circuits. Use pressure-sensitive plastic labels at exposed locations and similar labels or plasticized card stock tags at concealed boxes.

3. Label and paint the covers of the systems junction boxes as follows:

<u>SYSTEM</u>	<u>COLOR (ALL COLORS ARE KWAL PAINT)</u>	
Fire Alarm	Red Alert	AC118R
Sound/IC	Neon Blue	7076A
Telephone	Competition Yellow	7225A
Data	Java Green	AC098N
MATV	Flat Black	
Legally Required EM System	Red/Black Stripe	

E. Underground Electrical Line Identification.

- 1. During trench backfilling, for exterior underground power, signal, and communications lines, install continuous underground line detectable marking tape, located directly above line at 6 to 8 inches below finished grade. Where multiple lines are installed in a common trench or concrete envelope, do not exceed an overall width of 16 inches; install a single line marker.
- 2. Install detectable marking tape for all underground wiring, both direct-buried and in raceway.
- 3. Provide red marker dye applied to concrete encased ductbank.

F. Conductor Color Coding.

- 1. Provide color coding for secondary service, feeder and branch circuit conductors throughout the project secondary electrical system as follows:

<u>CONDUCTOR</u>	<u>208Y / 120V System</u>	<u>480Y / 277V System</u>
Phase A	Black	Brown
Phase B	Red	Orange
Phase C	Blue	Yellow
Shared/Single Neutral	White	Gray
Neutral A (dedicated)	White w/Black Stripe	Gray w/Black Stripe
Neutral B (dedicated)	White w/Red Stripe	Gray w/Orange Stipe
Neutral C (dedicated)	White w/Blue Stripe	Gray w/Yellow Stipe
Equipment Ground	Green	Green
Isolated Ground	Green w/Yellow Strip	Green w/Yellow Stripe

2. Switch legs, travelers and other wiring for branch circuits shall be of colors other than those listed above.
3. Use conductors with color factory applied the entire length of the conductors except as follows:
 - a. The following field-applied color-coding methods may be used in lieu of factory-coded wire for sizes larger than No. 10 AWG.
 - b. Apply colored, pressure-sensitive plastic tape in half-lapped turns for a distance of 6 inches from terminal points and in boxes where splices or taps are made. Apply the last two laps of tape with no tension to prevent possible unwinding. Use 1-inch-wide tape in colors as specified. Do not obliterate cable identification markings by taping. Tape locations may be adjusted slightly to prevent such obliteration.
 - c. In lieu of pressure-sensitive tape, colored cable ties may be used for color identification. Apply three ties of specified color to each wire at each terminal or splice point starting 3 inches from the terminal and spaced 3 inches apart. Apply with a special tool or pliers, tighten for snug fit, and cut off excess length.

G. Power Circuit Identification.

1. Securely fasten identifying metal tags or aluminum wraparound marker bands to cables, feeders, and power circuits in vaults, pull boxes, junction boxes, manholes, and switchboard rooms with 1/4-inch steel letter and number stamps with legend to correspond with designations on Drawings. If metal tags are provided, attach them with approximately 55-lb monofilament line or one-piece self-locking nylon cable ties.
2. Tag or label conductors as follows:
 - a. Future Connections: Conductors indicated to be for future connection or connection under another contract with identification indicting source and circuit numbers.
 - b. Multiple Circuits: Where multiple branch circuits or control wiring or communications/ signal conductors are present in the same box or enclosure (except for three-circuit, four-wire home runs), label each conductor or cable. Provide legend indicating source, voltage, circuit number, and phase for branch circuit wiring. Phase and voltage of branch circuit wiring may be indicated by mean of coded color of conductor insulation. For control and communications/signal wiring, use

- color coding or wire/cable marking tape at terminations and at intermediate locations where conductors appear in wiring boxes, troughs, and control cabinets. Use consistent letter/number conductor designations throughout on wire/cable marking tapes.
3. Match identification markings with designations used in panelboards shop drawings, Contract Documents, and similar previously established identification schemes for the facility's electrical installations.
- H. Apply warning, caution and instruction signs and stencils as follows:
1. Install warning, caution, or instruction signs where required by NEC, where indicated, or where reasonably required to assure safe operation and maintenance of electrical systems and of the items they connect. Install engraved plastic-laminated instruction signs with approved legend where instructions or explanations are needed for system or equipment operation. Install butyrate signs with metal backing for outdoor items. Warning and caution signs shall be furnished and installed on, but not be limited to the following equipment and locations:
 - a. Entrances to rooms and other guarded locations that contain exposed live parts 600 volts or less; signs shall forbid unqualified personnel to enter.
 - b. Switch and Overcurrent device enclosures with splices, taps and feed-through conductors. Provide warning label on the enclosures that identifies the nearest disconnecting means for any feed-through conductors.
 - c. Entrances to buildings, vaults, rooms or enclosures containing exposed live parts or exposed conductors operating at over 600 volts: DANGER-HIGH VOLTAGE-KEEP OUT.
 - d. Metal-enclosed switchgear, unit substations, transformers, enclosures, pull boxes, connection boxes and similar equipment operating at over 600 volts shall have appropriate caution signs and warning labels.
 - e. Indoor and Outdoor substations operating over 600 volts. Provide warning signs, instructional signs and single-line diagrams in accordance with NEC 225.70.
- I. Emergency Operating Signs: Install engraved laminated signs with white legend on red background with minimum 3/8-inch high lettering for emergency instructions on power transfer, load shedding, or other emergency operations.
- J. Install equipment/system circuit/device identification as follows:
1. Apply equipment identification labels of engraved plastic-laminate on each major unit of electrical equipment in building, including central or master unit of each electrical system. This includes communication/signal/alarm systems, unless unit is specified with its own self-explanatory identification. Except as otherwise indicated, provide single line of text, with 1/4"-high lettering on 1-inch-high label (1 1/2-inch-high where two lines are required) white lettering in black field. White lettering in red field for Emergency Power Systems. Text shall match terminology and numbering of the Contract Documents and shop drawings. Apply labels for each unit of the following categories of electrical equipment.
 - a. Panelboards (exterior and interior), electrical cabinets, and enclosures. For subpanels, identify feeder circuit served from.
 - b. Access doors and panels for concealed electrical items.
 - c. Motor starters, including circuit origination, HP, heater size, FLA, and mechanical equipment designation.

- d. Disconnect switches.
 - e. Pushbutton stations.
 - f. Power transfer equipment.
 - g. Contactors.
 - h. Control devices.
 - i. Telephone switching equipment.
 - j. Fire alarm master station or control panel.
 - k. Busduct – Label all cable tap boxes, bus plug-in units, etc. with plastic laminate labels designating load served.
 - l. Variable frequency drives.
 - m. Lighting Control Equipment.
- K. Post Conductor-Identification-Means labels at locations of switchboards, distribution panels and branch circuit panels. The labels shall identify the color-coding used on ungrounded conductors for each voltage system used on the premises.
- L. Apply Available-Fault-Current labels at the service entrance equipment.
- M. Apply Source-of-Supply labels on the exterior covers of equipment (except in single- or two-family dwellings) as follows:
- 1. Each switchboard supplied by a feeder.
 - 2. Each branch circuit panelboard supplied by a feeder.
 - 3. Each feeder disconnect, branch circuit disconnect, panelboard or switchboard in a remote building or structure.
- N. The label shall identify the device or equipment where the power supply originates, and the system voltage, phase or line and system at all termination, connection and splice points. For example: Feeder Power Supply for Panel “XX” Originates at Panel “XX” (or Switchboard “XX”, Transformer “XX”, Switch “XX”, etc.); 120/208 volts, 3-phase, Phase Color Identification (or 120/240, 277/480, etc.).
- O. Install Arc-flash hazard labels on the following equipment:
- 1. Each individually mounted circuit breaker.
 - 2. Each branch circuit panelboard.
 - 3. Each individually mounted motor starter.
- P. Apply circuit/control/item designation labels of engraved plastic laminate for disconnect switches, breakers, pushbuttons, pilot lights, motor control centers, and similar items for power distribution and control components above, except panelboards and alarm/signal components, where labeling is specified elsewhere.
- Q. Install labels at locations indicated and at locations for best convenience of viewing without interference with operation and maintenance of equipment.
- R. Engrave all receptacle plates other than those serving 120 volt, single phase devices. State voltage and amperage characteristics: Example; “208V 30A”.
- S. Mark each device box (for each type of wiring device) with a permanent ink felt tip marker, indicating the circuit that the device is connected to: Example; “CKT A-1”
- T. Label circuit breaker feeding fire alarm panel “Fire Alarm Circuit”. Using plastic laminate label, white lettering on a red background.

END OF SECTION 260553

SECTION 260923 - OCCUPANCY SENSORS**PART 1 – GENERAL****1.1 RELATED DOCUMENTS:**

- A. Drawings and general provisions of Contract, including General and Supplementary Conditions and Division-1 Specification sections, apply to work of this section.
- B. This section is a Division-26 Basic Materials and Methods section, and is part of each Division-26 section making reference to wiring devices specified herein.

1.2 DESCRIPTION OF WORK:

- A. The extent of occupancy sensor work is indicated by drawings and schedules.
- B. Types of occupancy sensors in this section include the following:
 - 1. Control Pack
 - 2. Dual Technology Wall Switch
 - 3. Dual Technology Wall Switch with Dimming and Daylight Control.
 - 4. Dual Technology Ceiling Sensor w/ Control Pack

1.3 QUALITY ASSURANCE:

- A. Comply with NEC and NEMA standards as applicable to construction and installation of occupancy sensors. Provide occupancy sensors that have been UL listed and labeled.
- B. All sensors shall be capable of operating normally with electronic ballasts, PL lamp systems, motor loads and any other passive infrared or microwave systems.

1.4 SUBMITTALS: Refer to Section 26 0502 for requirements.**PART 2 - PRODUCTS**

2.1 MANUFACTURER: The manufacturer shall have a minimum of five years of experience in the sensor and lighting control industry. Sensors and related relays shall be compatible with the specific lighting types controlled. All sensors shall be of the same manufacturer, mixing brands of sensors is not acceptable.

- A. **DUAL TECHNOLOGY WALL SWITCH:** Where units are indicated provide a sensor that meets the following minimum requirements:
 - 1. Sensor shall utilize PIR (Passive Infrared) to turn on the lights and then PIR or US (Ultrasonic) technologies to keep lights on.
 - 2. Sensor shall incorporate an inrush current limiter circuit to protect the relay contacts.
 - 3. Sensor shall utilize single or dual dry relay contacts for control of the lighting loads. Contractor shall verify requirements in coordination with the drawings.
 - 4. Sensor shall have a self-adjusting time delay, selectable 5, 15 and 30 minutes.
 - 5. Sensor shall have automatic sensitivity adjustment and be microprocessor controlled.
 - 6. Sensor shall have light level sensing 0 to 200 footcandles.

7. Sensor shall have a 180 degree field of view, coverage up to 800 square feet and shall detect 6 inches of hand movement towards the sensor up to 300 square feet; and body motion towards the sensor up to 1000 square feet.
 8. Sensor shall be rated for 0 to 800 watts at 120VAC and 0 to 1200 watts at 277VAC.
 9. Sensor shall be automatic on and shall have an automatic to off override switch on the unit. Switch shall be equipped with an air gap switch to disconnect power to the lighting load.
 10. Sensor shall have real time motion indicator on the front of the unit.
 11. Sensor shall mount to a single gang switch box.
 12. Subject to compliance with the above requirements. Provide models of one of the following:
 - a. Greengate ONW-DT
 - b. Sensor Switch WSX PDT Series
 - c. Douglas WOS Series
- B. DUAL TECHNOLOGY WALL SWITCH WITH DIMMING AND DAY-LIGHT CONTROL: Where units are indicated, provide a sensor that meets the following minimum requirements:
1. Dual technology sensors shall have one of its two technologies, not require motion to detect occupancy.
 2. Sensors shall offer a minimum on timer of at least 15 minutes, in order to prevent all cycling of lamps before they have burned for the lamp manufacturers minimum recommended time period.
 3. Sensors shall utilize an occupancy time delay that keeps lights on after last detected occupancy. Factory default setting of the occupancy time delay shall be 15 minutes.
 4. Manual adjustment to the occupancy time delay so as to increase it shall be accommodated.
 5. Sensor shall be capable of switching both 120 VAC and 277 VAC.
 6. Sensor shall recess into single gang switch box and fit standard GFI opening.
 7. Sensor shall meet NEC grounding requirements by providing a dedicated ground connection and intrinsically grounding through its mounting strap.
 8. Line and load wire connections shall be interchangeable.
 9. Wall switch sensor shall have field programmable adjustments for selecting operational modes, occupancy time delays, minimum on time, and photocell set-point.
 10. Sensor shall be capable of both auto-on and manual operation.
 11. Combination photocell/dimming sensors set point and deadband shall be automatically calibrated through the sensors microprocessor by initiating the automatic set point programming procedure. Min and max dim settings as well as set point may be manually entered.

12. Subject to compliance with the above requirements, provide models of one of the following:
 - a. Sensor-Switch – WSX-PDT-D Series
 - b. Green Gate – CSW-d-010
- C. DUAL TECHNOLOGY CEILING SENSOR: Where units are indicated, provide a sensor that meets the following minimum requirements:
 1. Sensor shall incorporate ultrasonic (microphonics) and infrared technologies in a single unit.
 2. Sensor shall be Class 2, low voltage; capable of mounting in the ceiling for maximum coverage.
 3. Sensor shall use internal microprocessor for motion signal analysis and automatic self-adjustment.
 4. Sensor shall have automatic self-adjustment algorithm that adjusts timer and sensitivity settings to maximize performance and minimize energy usage.
 5. Sensor shall have manual time-out adjustment from 8 minutes to 32 minutes and automatic time out from 8 minutes to 100 minutes.
 6. Sensor shall have test time-out setting of 8 seconds, with automatic return to 8 minutes after one hour if sensor is left in test mode.
 7. Sensor's microprocessor shall automatically extend timer by 1 hour in response to recognition to false off condition. After 5 hours, sensor reduces extended time by 30 minutes and continues to reduce by 30 minute increments over the next few days.
 8. Sensor's microprocessor shall automatically reduce either PIR or ultrasonic sensitivity in response to false on condition.
 9. Sensor microprocessor will automatically monitor PIR background threshold signal level and makes corresponding sensitivity adjustments automatically.
 10. Sensor microprocessor algorithm shall incorporate automatic adaptation to continuous airflow.
 11. For airflow that is so intense as to mask motion, sensor shall flash indicator LED code to indicate excessive airflow.
 12. Sensor's microprocessor shall use a four week learning period and develop a circadian calendar.
 13. An internal 24 hour 7 day clock establishes what periods the room is typically occupied, biasing sensor to keep lights on while normally occupied and off when normally unoccupied.
 14. Sensor shall have selection settings for the following dual technology schemes:
 - a. High Sensitivity and High Confidence (miser mode)
 15. Sensor shall be available with either 180 degrees or 360 degrees coverage pattern.
 16. Infrared lens shall have 360 degree field of view. Two types of lens shall be available, standard and extra dense.
 17. Sensor shall have a variety of mask inserts for PIR coverage rejection to prevent false tripping.
 18. Transducers shall be protected from tampering.
 19. Sensor shall have manual adjustments for timer and sensitivities and override switches to force manual adjustment mode.

20. Sensor shall have adjustable sensitivity from 0% to 100% for both ultrasonic and infrared.
 21. Controls shall be behind cover to resist tampering. All adjustments shall be accessible from the front of the sensor.
 22. Sensor shall be available with a photocell adjustment from 20 to 3,000 Lux.
 23. Sensor shall provide internal operating status and settings confirmation via LED motion lamp indicator.
 24. Sensor shall have two (if 180 degree) or three (if 360 degree) real time LED motion indicators visible from the front of the unit: Red = infrared; green = ultrasonic.
 25. Subject to compliance with the above requirements, provide models of one of the following:
 - a. Hubbell-ATD Series
 - b. Sensor Switch-CM-PDT 9/10 Series
 - c. Wattstopper-DT Series
 - d. Mytech-Omni-DT Series
 - e. Leviton – OSC UOW Series
 - f. Greengate OAC– DT Series
 - g. Douglas – WOR Series
- D. 24 VDC POWER/CONTROL PACK: Where units are indicated, provide a power/control pack that meets the following minimum requirements:
1. Control module shall consist of a DC power supply and a dry contact relay for switching a lighting load.
 2. Control module shall be available in versions to accept 120, and 277 VAC line voltages.
 3. Output shall be 24VDC nominal, and shall be inherently safe, low voltage, limited power output (Class 2).
 4. Output shall supply 100mA current, in addition to current consumed internally to operate internal relay.
 5. Relay shall utilize normally open, silver alloy dry contacts, and shall be rated for a 20A ballast load at 120V and 277V.
 6. Relay function shall not require more than 5 mA control current to operate.
 7. Control module shall have line voltage wiring, consisting of input voltage and relay contact connections, exiting from one end, and low voltage DC connections, consisting of ground, power, and control wires, exiting from the other end.
 8. Control module shall be sized to fit inside a standard 4" x 4" junction box.
 9. Control module shall be equipped with a 1/2" EMT threaded male fitting on the line voltage end, such that it may be mounted to the outside of a junction box with the line voltage wiring internal to the box and the low voltage wiring external.
 10. Control module shall be equipable with accessory 1/2" EMT threaded male fitting on the low voltage end, such that it may be mounted to the inside of a ballast cavity with the box and line voltage wiring internal to the cavity and the low voltage wiring external.
 11. Slave module shall be available for switching additional circuits. Slave module has same construction and specifications as control module except without power supply function.

12. Subject to compliance with the above requirements, provide models of one of the following:
 - a. Hubbell-CU Series
 - b. Wattstopper-BEP Series
 - c. Greengate SP20-MV Series
 - d. Leviton – OSC/OSA Series
 - e. Douglas – WP-PP

PART 3 – EXECUTION

3.1 INSTALLATION OF LIGHTING CONTROL EQUIPMENT:

- A. Install occupancy lighting control system components and ancillary equipment as indicated, in accordance with equipment manufacturer's written instructions, and with recognized industry practices, to ensure that lighting control equipment complies with requirements.
- B. Comply with requirements of NEC, and applicable portions of NECA's "Standard of Installation" pertaining to general electrical installation practices.
- C. Coordinate with other electrical work, including raceways, and electrical boxes and fittings, as necessary to interface installation of lighting control equipment work with other work.
- D. Contractor shall be on site as required, to adjust lighting control units for proper operation.
- E. Mount the switchpack in a standard 4" junction box. Mount sensor to a standard 4" junction boxes. Refer to manufacturer supplied mounting instructions.
- F. Spare Parts: Refer to Section 26 0502 for requirements.

3.2 FIELD QUALITY CONTROL:

- A. Upon completion of installation and after circuitry has been energized, demonstrate capability and compliance of system with requirements.
- B. System start-up: Provide a factory authorized technician to verify the installation and test the system.
- C. Where possible, correct malfunctioning units at site, then retest to demonstrate compliance; otherwise, remove and replace with new units, and proceed with retesting.
- D. Contractor shall visit the job site 3 months after the owner has taken occupancy and adjust any units not operating properly, otherwise remove and replace with new units.

3.3 PRODUCT SUPPORT AND SERVICES:

- A. System Start-Up: Provide a factory authorized technician to verify the installation, test the system, and train the owner on proper operation and maintenance of the system. Before requesting start-up services, the installing contractor shall verify that:
 1. The sensors have been fully installed in accordance with manufacturer's installation instructions.
 2. Low voltage wiring for overrides and sensors is completed.
 3. Accurate 'as-built' load schedules have been prepared.
 4. Proper notification of the impending start-up has been provided to the owner's representative.

5. Programming of all switches, sensors, power packs, relays, etc. shall be completed by factory authorized technician, prior to final and training.
- B. Factory support: Factory telephone support shall be available at no cost to the owner during the warranty period. Factory assistance shall consist of assistance in solving programming or other application issues pertaining to the control equipment. The factory shall provide a toll free number for technical support.
- C. Functional Testing:
1. The owner shall hire a third party that will conduct and certify the functional testing.
 2. Lighting controls devices shall be tested to ensure that control hardware and software are calibrated, adjusted, programmed, and in proper working conditions in accordance with the construction documents, manufacturer's instructions and code requirements. The following shall be performed:
 - a. Certify that sensors have been located, aimed and calibrated per manufacturer recommendations.
 - b. Status indicator operates properly.
 - c. Fixtures that are controlled by auto-on controls turn on to permitted level.
 - d. Fixtures that are controlled by manual on controls operate when manually activated.
 - e. Fixtures do not turn on incorrectly due to HVAC or movement outside the controlled area.
 - f. Confirm that occupancy sensors turn off after space is vacated and do not turn on unless space is occupied.
 - g. Simulate unoccupied conditions and confirm that vacancy sensors only turn on manually and turn off after space is vacated.
 3. The party responsible for the functional testing shall provide documentation that the installed lighting controls meet or exceed all performance criteria and shall not be directly involved in the design or construction of the project.

3.4 WARRANTY:

- A. Manufacturer shall provide a one (1) year limited warranty on lighting control system. A ten (10) year limited warranty shall be provided on the lighting control relays.

3.5 RECORD DRAWINGS: Refer to Section 26 0502 for requirements.

3.6 TRAINING

- A. Provide one (1) hour of video taped training in a one hour session on the operation and use of the lighting control equipment, at job site, at no cost to the Owner.

3.7 MANUFACTURER AUTHORIZED PERSONNEL TRAINING:

- A. Building Operating Personnel Training: Train Owner's building personnel in procedures

for starting-up, testing and operating lighting control system equipment.

END OF SECTION 260923

BLANK PAGE

SECTION 260943 - LIGHTING CONTROL EQUIPMENT

PART 1 – GENERAL

1.1 RELATED DOCUMENTS:

- A. Drawings and general provisions of Contract, including General and Supplementary Conditions and Division-1 Specification sections, apply to work of this section.
- B. Division-26 Basic Materials and Methods sections apply to work specified in this section.

1.2 DESCRIPTION OF WORK:

- A. Extent of lighting control equipment work is indicated by drawings and schedules, and is hereby defined to include, but not by way of limitation, lighting control panels, control stations and other user interface devices, wiring and ancillary equipment.
- B. Types of lighting control equipment specified in this section, includes the following:
 - 1. Low voltage relay control panels
 - 2. Occupancy sensors
 - 3. Daylight sensors
 - 4. Wallstations/Switches
 - 5. Lighting Load Controllers (Room Controllers)
 - 6. Emergency Lighting Control Units/Generator Transfer Devices
- C. Requirements are indicated elsewhere in these specifications for work including but not limited to raceways, electrical boxes and fittings required for installation of lighting control equipment, not work of this section.

1.3 QUALITY ASSURANCE:

- A. Manufacturers: Firms regularly engaged in manufacture of lighting control equipment and ancillary equipment, of types and capacities required, whose products have been in satisfactory use in similar service for not less than 5 years. To ensure a uniform installation and single responsibility, all switching and dimming equipment described herein shall be supplied by a single manufacturer.
- B. Installer: Qualified with at least 3 years of successful installation experience on projects with lighting control equipment installation work similar to that required for project.
- C. NEC Compliance: The control system shall comply with all applicable National Electrical Codes regarding electrical wiring standards.
- D. NEMA Compliance: The control system shall comply with all applicable portions of the NEMA Standard regarding the types of electrical equipment enclosure.
- E. Codes and Standards: Provide units that meet the requirements of IEEE Std. 2000.1.1999.
- F. Independent Testing Laboratory: Provide units that have been tested and listed under UL

916 energy management equipment.

- G. Component Pre-testing: All control equipment shall undergo strict inspection standards. The equipment shall be previously tested and burned-in at the factory prior to installation.

1.4 SUBMITTALS: Refer to Section 26 0502 for requirements.

PART 2 - PRODUCTS

2.1 ACCEPTABLE MANUFACTURERS:

- A. Manufacturer: Subject to compliance with requirements, provide lighting control equipment of one of the following;
1. **GreenGate Controls (Eaton)**
 2. Acuity nLight
 3. Douglas Lighting Controls
 4. Hubbell Building Automation
- B. **The lighting controls as shown are based upon Eaton GreenGate lighting controls. Prior approval and commitment to being able to provide similar and equal system is required before bidding this project. Any system different from Eaton Controls that require additional relays, etc. not shown on plans due to lack of separation of relays and dimming zones must be accounted for and provided in the bid and must function as similar to that which is required in final installation.**

2.2 SYSTEM DESCRIPTION:

- A. The lighting control system shall provide seamless control and monitoring of all lighting included in the scope of work regardless of whether it is relay switched or dimmed.
- B. The lighting control system shall consist of low voltage relay control panels with programmable switch inputs, the panel shall be microprocessor controlled with a touchscreen interface display. The touchscreen shall provide relay status information viewable through a protected windowed enclosure. All local programming shall be permissible through the self-prompting touchscreen.
- C. Programmable intelligence shall include:
1. Time of day control (64 time-of-day/holiday schedules)
 2. 32 holiday dates
 3. Timed inputs (adjustable from 1 to 99 minutes)
 4. Timed override (from touchscreen, adjustable from 1 to 999 minutes, then resumes normal schedule)
 5. Pre-set controls
 6. Auto daylight savings adjust
 7. Low voltage Dimming/Central Dimming Controls:
 - a. 0-10V dimming capability
 - b. Daylighting control via 0-10V dimming relays and programming
 - c. DMX or other dimming protocols as indicated on plans
 8. Astronomical clock with offsets
 9. Local control (from touchscreen and local switch)

10. Digital wallstations/switches
 11. Flash warning of impending off for occupants
 12. Network override
- D. The controller shall permit lighting to be overridden on for after-hours use or cleaning. The controller shall provide priority and masking choices to allow for customizing the functions of switch inputs, thereby enabling wallstations/switches to function differently at different times of day. These overrides shall be digital, network or hard-wired inputs.
- E. The lighting control system shall be fully programmable through PC programming software. Programming shall be permitted through a direct RS-232 connection, modem or TCP/IP.
1. Shall include with user-friendly software suitable for operation on computer workstations which serve as central control stations for the selection and operation of lighting scenes.
 2. All software shall be programmed by the vendor and delivered ready to use. This program shall include preparation of all graphics, and displays required as a part of this project.
- F. The control system shall provide networking between lighting control panels. The network shall support up to a maximum of 254 control panels. Panels shall permit data sharing for global controls. All inputs shall be transferable over the network to create any switching pattern.
- G. The lighting control system shall log all control events. Log reports shall be available through the integral touchscreen or enterprise software.
- H. All lighting programming shall meet the requirements of the IECC 2017 or current energy code applied to the project.

2.3 EQUIPMENT:

- A. Room Controllers:
1. The room controller shall provide the following functionality;
 - a. Provide interface with room occupancy sensor to provide lighting and receptacle control and be programmable as either manual on/automatic off. Provide interface with room wallstations to provide multi-level switching and/or variable dimming. Provide interface with daylight sensors to provide daylighting controls of lighting fixture via multi-level (step dimming) and/or variable dimming.
 2. Provide with network interface to tie to building relay panel
 3. The room controller shall be a fully functional lighting control system to match the room lighting and control requirements. The controller shall provide the following features:
 - a. Separate compartments for line voltage, emergency voltage and low voltage connections.
 - b. Breakouts for direct conduit connections.
 - c. Dual voltage (120/277 VAC)
 - d. Low voltage connections using standard RJ-45 connectors.

- e. Zero cross circuitry for each load.
 - f. Relay and 0-10V dimming zone configuration to match room requirements.
 - g. The ability to be independently program or be re-programmed on site and without the need to replace or send the device to the manufacturer for re-programming.
4. Emergency Lighting: When the room controller is provided with emergency relay, the controller shall be UL 924 Listed and monitor the normal power circuit. The UL 924 relay will track the normal power operation. Upon loss of normal power the emergency lighting will be forced on to full bright (if dimming) until normal power is restored. The following features shall be included:
- a. 120/277 VAC
 - b. Push-to-test
5. Daylight sensors shall work with the room controller to provide automatic daylight dimming capabilities for loads connected to the room controller. The daylight sensor shall include the following features:
- a. An additional photodiode that measures only the visible spectrum.
 - b. The sensor shall have three light level ranges;
 - i. Low (3-300 LUX), high (30-3000 LUX) and direct sun (300-30,000 LUX).
 - c. The sensor shall provide the capability of controlling multiple (up to three) daylight zones for dimming daylight harvesting.
 - d. The sensor shall include an internal photodiode that measures light in a 60 degree angle cutting off the unwanted light from the interior of the room.
6. Ceiling Mounted Occupancy Sensors: Sensors shall utilize dual-technology (ultrasonic and infrared technologies) and have the following additional features:
- a. Sensor shall be class 2, low voltage; capable of mounting in the ceiling for maximum coverage.
 - b. Sensor shall have automatic self-adjustment algorithm that adjusts timer and sensitivity settings to maximize performance and minimize energy usage.
 - c. Sensor shall have 360 degree field of view.
 - d. Sensor shall incorporate non-volatile memory such that all settings and parameters are saved in protected memory.
 - e. Sensor shall have time delays from 10 to 30 minutes.
 - f. Sensor shall provide a visual means of indication that motion is being detected via an LED.
 - g. Sensors shall have readily accessible, user adjustable settings for time delay and sensitivity.
 - h. Where specified, the sensor shall have an internal additional isolated relay with NO, NC and common outputs for use with HVAC control, data logging and other control options.
7. Wallstations: Provide low voltage push-button type switches up to 8 button configurations to match requirements of lighting control within the room. Provide factory engraved labeling for individual push buttons. Provide in a color to match wiring devices and coverplates to match devices and plates in Wiring Devices (Section 26 2726). Wallstation shall connect to the room controller via the room

controller local network. Wallstations that require user interface to allow for raise/lower control of dimming, loads shall include a slider function or similar. All wallstations shall have the ability to be independently program or be re-programmed on site and without the need to replace or send the device to the manufacturer for re-programming.

- B. Emergency Power Control (CEPC)/ Emergency Lighting Control Units (ELCU)/Generator Transfer Devices (Required when not built into Room Controller, Relay Panel, etc):
1. The Emergency Power Control (CEPC)/Lighting Control Unit (ELCU) shall provide all required functionality to allow any standard lighting control device to control emergency lighting in conjunction with normal lighting in any area within a building. The unit shall be installed flush to the ceiling so that test switch & LED's are in plain view of room occupants as required by some local electrical codes.
 2. The device shall automatically illuminate connected emergency loads upon utility power interruption, regardless of room switch position. (NEC 700.24)
 3. Local room switch or lighting control shall turn both regular & emergency luminaires on at the same time (no dedicated emergency room switch required).
 4. The emergency lighting control unit shall allow control of emergency lighting fixtures in tandem with normal lighting in an area while ensuring that emergency lighting will turn on immediately to full brightness upon loss of normal power supplying the control device. Emergency lighting operation shall be independent for each controlled area and shall not require a generalized power failure for proper operation.
 5. The unit shall be compatible with 2-wire, 3-wire, 0-10V, & DALI dimming systems & ballasts.
 6. The device shall be self-contained, measure 1.70" x 2.97" x 1.64," and provide integral one half inch pip nipple mount with snap in locking feature for mounting into a standard junction box KO.
 7. The device shall have normally closed dry contacts capable of switching 20 amp emergency ballast loads @ 120-277 VAC, 60 Hz, or 10 amp tungsten loads @ 120 VAC, 60 Hz.
 8. The device shall have universal rated voltage inputs provided for normal power sense and normal switched power at 120-277 VAC, 60 Hz.
 9. The device shall have an integral momentary test switch. Pressing and holding this switch shall instantly force the unit into emergency mode and turn on emergency lighting. Releasing the test switch shall immediately return the unit to normal operation.
 10. The unit shall provide dedicated leads and 24 VDC source for connection to remote test switch, fire alarm system, or other external system capable of providing a normally closed dry contact closure. Breaking contact between the terminals shall force and hold the emergency lighting on until the terminals are

again closed. An integral LED indicator shall indicate the unit's current remote activation status.

11. The device shall provide separate LEDs to indicate the presence of normal and emergency power sources. The LEDs shall indicate the unit's current operational mode (normal or emergency).
12. The device's normal power input lead shall be connected to the line side of the control device such that any upstream fault causing a loss of power, including the tripping of the branch circuit breaker, will force the unit into the emergency mode and turn on the emergency lighting.
13. The unit shall automatically switch emergency lighting on and off as normal lighting is switched. When normal power is not available, the unit shall force and hold emergency lighting on regardless of the state of any external control device until normal power is restored.
14. The unit shall utilize zero crossing circuitry to protect relay contacts from the damaging effects of inrush current generated by switching electronic ballast loads.
15. The unit shall have UL 94-V0 or UL 94-5VA flame rating & be approved for installation above the suspended ceiling.
16. To ensure quality and reliability, the unit shall be manufactured by an ISO 9002 certified manufacturing facility and shall have a defect rate of less than 1/3 of 1%.
17. The device shall not generate any objectionable electrical or mechanical noise.
18. The unit shall be UL and cUL listed and labeled for connection to both normal and emergency lighting power sources.

PART 3 - EXECUTION:

3.1 INSTALLATION OF LIGHTING CONTROL EQUIPMENT:

- A. Install lighting control system components and ancillary equipment as indicated, in accordance with equipment manufacturers written instructions, and with recognized industry practices, to ensure that lighting control equipment complies with requirements.
- B. Comply with Requirements of NEC, and applicable portions of NECA's 'Standard of Installation' pertaining to general electrical installation practices.
- C. Coordinate with other electrical work, including raceways, electrical boxes and fittings, as necessary to interface installation of lighting control equipment work with other work.
- D. Electrical Identification: Refer to Section 26 0553 for requirements.

3.2 FIELD QUALITY CONTROL:

- A. Upon completion of installation and after circuitry has been energized, demonstrate

capability and compliance of system with requirements.

- B. Where possible, correct malfunctioning units at site, then retest to demonstrate compliance; otherwise, remove and replace with new units, and proceed with retesting.

3.3 PRODUCT SUPPORT AND SERVICES:

- A. System Start-Up: Provide a factory authorized technician to verify the installation, test the system, and train the owner on proper operation and maintenance of the system. Before requesting start-up services, the installing contractor shall verify that:
 - 1. The control system has been fully installed in accordance with manufacturer's installation instructions.
 - 2. Low voltage wiring for overrides and sensors is completed.
 - 3. Accurate 'as-built' load schedules have been prepared for each lighting control panel.
 - 4. Proper notification of the impending start-up has been provided to the owner's representative.
 - 5. Programming of all wallstations/switches, relays, groups of relays and interfaces with building automation shall be completed by factory authorized technician, prior to final and training.
- B. Factory support: Factory telephone support shall be available at no cost to the owner during the warranty period. Factory assistance shall consist of assistance in solving programming or other application issues pertaining to the control equipment. The factory shall provide a toll free number for technical support.

3.4 PROGRAMMING:

- A. Program of all lighting control systems as directed by the electrical engineer and/or owner. Meet with the electrical engineer at their office prior to preparation of shop drawings to discuss specific programming and zoning requirements of system(s). Each networked or standalone system shall be programmed to revert back to its normal "ON" position one hour after selecting a scene or raising or lowering a lighting zone.
- B. All lighting programming shall meet the requirements of the IECC 2017 or current energy code applied to the project.

3.5 COMMISSIONING:

- A. A lighting control system requires at least one site visit for proper commissioning. If multiple site visits are required, the first ensures that the contractor is trained to install the system correctly. On the second, the factory trained engineer will start up the system, ensure that it is operating according to specification, and perform initial programming. The third visit is for the purposes of refining the programming, and training the owner/end user on the system.
- B. Provide factory-certified field service engineer to ensure proper system installation and operation under following parameters:
 - 1. Certified by the equipment manufacturer on the system installed.
 - 2. Site visit activities:

- a. Verify connection of power feeds and load circuits.
 - b. Verify connection of controls.
 - c. Verify system operation control by control, circuit by circuit.
 - d. Obtain sign-off on system functions.
 - e. Demonstrate system capabilities, operation and maintenance and educate Owner's representative on the foregoing.
3. At least three site visits to accomplish the following tasks:
- a. Prior to wiring:
 - i. Review and provide installer with instructions to correct any errors in the following areas:
 1. Low voltage wiring requirements
 2. Separation of high and low voltage wiring runs
 3. Wire labeling
 4. Load schedule information
 5. Switching cabinet locations and installation
 6. Physical locations and network addresses of controls
 7. Ethernet connectivity
 8. Computer-to-network connections
 9. Load circuit wiring
 10. Connections to other systems and equipment
 11. Placement and adjustment of Occupancy Sensors
 12. Placement and adjustment of Photocells
 - b. After system installation:
 - i. Check and approve or provide correction instructions on the following:
 1. Connections of power feeds and load circuits
 2. Connections and locations of controls
 3. Connections of low voltage inputs

4. Connections of the data network

- ii. Turn on system control processor and upload any pre-programmed system configuration
 - iii. Verify cabinet address(es)
 - iv. Upload pre-programmed system configuration and information to switching and/or dimming cabinets
 - v. Check load currents and remove bypass jumpers
 - vi. Verify that each system control is operating to specification
 - vii. Verify that each system circuit is operational according to specification
 - viii. Verify that manufacturers' interfacing equipment is operating to specification
 - ix. Verify that any computers and software supplied by the manufacturer are performing to specifications
 - x. Verify that any remote WAN (Wide Area Network) connections are operating properly
 - xi. Have an owner's representative sign off on the above-listed system functions
- c. Before project completion and hand-off:
- i. Demonstrate system capabilities and functions to owner's representative
 - ii. Train owner's representative on the proper operation, adjustment, and maintenance of the system.
- C. Notification: Upon completion of the installation, the contractor shall notify the manufacturer that the system is ready for formal checkout. Notification shall be given in writing a minimum of 21 days prior to the time factory-trained personnel are required on site. Each field installed RJ45 connection must be tested prior to system interconnection. A test report must be furnished to manufacturer prior to scheduling commissioning activity. Manufacturer shall have the option to waive formal turn-on.
- D. Turn-On: Upon completion of all line, load and interconnection wiring, and after all fixtures are installed and lamped, Manufacturer's Certified Technician shall completely check the installation prior to energizing the system. Each installed relay system shall be tested for proper ON/OFF operations, and proper LED illumination. Each installed control cabinet shall be tested verifying that each controlled load adjusts to the selected setting and that all switch LED's illuminate properly.
- E. At the time of checkout and testing, the owner's representative shall be thoroughly instructed in the proper operation of the system.

3.6 MAINTENANCE:

- A. Enable the end user to order new equipment for system expansion, replacements, and spare parts.
- B. Make new replacement parts available for a minimum of ten years from the date of manufacture.
- C. Manufacturing shall provide telephone technical support by factory personnel 24 hours a day, 7 days a week. Project cost overruns and delays can occur without this service. Answering services can add to frustration and delay the resolution of any problems or issues. Manufacturers who do not offer factory-direct technical support on a 24/7 basis should not be acceptable on this project.
- D. Provide factory-direct technical support hotline 24 hours per day, 7 days per week.
- E. Offer renewable annual service contracts, to include parts, factory labor, and annual training visits. Make service contracts available up to ten years after date of system commissioning.

3.7 WARRANTY:

- A. Manufacturer shall provide a one (1) year limited warranty on lighting control system. A ten (10) year limited warranty shall be provided on the lighting control relays.

3.8 RECORD DRAWINGS: Refer to Section 26 0503 for requirements.**3.9 TRAINING:**

- A. Provide one (1) hour of video taped training in a one hour session on the operation and use of the lighting control equipment, at job site, at no cost to the Owner.
- B. Provide a CD or USB device to the owner containing the information specified below. The media shall include all information required to allow the Owner to change the schedules themselves. The media shall contain a minimum of following:
 - 1. CAD drawing files of 'as-built' lighting control components and point to point connections.
 - 2. General configuration programming.
 - 3. Job specific configuration programming to include schedule.
- C. Tutorial file on complete programming of lighting control system

END OF SECTION 260943

SECTION 262416 - PANELBOARDS**PART 1 – GENERAL****1.1 RELATED DOCUMENTS:**

- A. Drawings and general provisions of Contract, including General and Supplementary Conditions and Division-1 Specification sections, apply to work of this section.
- B. This section is a Division-26 Basic Materials and Methods section, and is part of each Division-26 section making reference to panelboards specified herein.

1.2 DESCRIPTION OF WORK:

- A. The extent of panelboard and enclosure work, is indicated by drawings and schedules.
- B. Types of panelboards and enclosures in this section include lighting and appliance panelboards, and power distribution panelboards.

1.3 QUALITY ASSURANCE:

- A. Provide units that have been UL listed and labeled. Comply with NEC as applicable to installation of panelboards, cabinets, and cutout boxes. Comply with NEC pertaining to installation of wiring and equipment in hazardous locations. Comply with NEMA Stds. Pub No. 250, "Enclosures for Electrical Equipment (1000 volt maximum). Pub No. 1, "Instructions for Safe Installation, Operation and Maintenance of Panelboards Rated 600 Volts or Less".

1.4 SUBMITTALS: Refer to Section 26 0503 for requirements.**PART 2 – PRODUCTS****2.1 ACCEPTABLE MANUFACTURERS:**

- A. Subject to compliance with requirements, provide of one of the following:
 - 1. Cutler Hammer Products, Eaton Corp.
 - 2. General Electric Company
 - 3. Siemens Energy & Automation, Inc.
 - 4. Square D Company (Basis of Design)

2.2 PANELBOARDS:**A. GENERAL:**

- 1. Except as otherwise indicated, provide panelboards, enclosures and ancillary components, of types, sizes, and ratings indicated. Equip with number of unit panelboard devices as required for complete installation. Fully equip "spaces" with hardware to receive breaker or switch of size indicated. Provide CU/AL rated lugs of proper size to accommodate conductors specified.

B. LIGHTING AND APPLIANCE PANELBOARDS:

- 1. Provide dead-front safety type lighting and appliance panelboards as indicated, with switching and protective devices in quantities, ratings, types, and arrangement shown. Provide bolt-on thermal magnetic type branch breakers.

Where multiple breakers are indicated, provide with common trip handle. Series rated systems are not acceptable. Equip with aluminum bus bars, full-sized neutral bus, and ground bus.

C. PANELBOARD ENCLOSURES:

1. Provide galvanized sheet steel cabinet type enclosures, in sizes and NEMA types as indicated, code-gage minimum 16-gage thickness. Provide door-in-door hinged fronts. Provide fronts with adjustable indicating trim clamps, and doors with flush locks and keys, all panelboard enclosures keyed alike, with concealed door hinges and door swings as indicated. Equip with interior circuit-directory frame, and card with clear plastic covering. Provide baked gray enamel finish over a rust inhibitor. Provide enclosures fabricated by same manufacturer as overcurrent devices contained therein Bolt engraved plastic laminate labels indicating panel name and voltage on the interior and exterior of panelboards.
2. Verify that the physical size of the Power Distribution Panelboards and Panelboards match the space provided in the locations shown. Coordinate with the manufacturer to ensure that the Power Distribution Panelboard and Panelboards are manufactured in relation to the space allocated.
3. Provide floor to ceiling panel extensions for all surface mounted panels located outside of mechanical and electrical rooms.

D. FINISH:

1. Coat interior and exterior of surface with manufacturer's standard color; baked on enamel finish.

E. ELECTRICAL IDENTIFICATION:

1. Refer to Section 260553 for requirements.

PART 3 – EXECUTION

3.1 INSTALLATION OF PANELBOARDS:

A. GENERAL:

1. Install panelboards and enclosures where indicated, in accordance with manufacturer's written instructions, applicable requirements of NEC and NECA's "Standard of Installation", in compliance with recognized industry practices to ensure products fulfill requirements.
2. Provide a surge protective device on each panelboard located on the emergency distribution system. Refer to section 26 4313 for requirements.

B. MOUNTING:

1. Coordinate installation of panelboards and enclosures with cable and raceway installation work. Anchor enclosures firmly to walls and structural surfaces, ensuring they are permanently and mechanically secure. Arrange conductors neatly within enclosure, and secure with suitable nylon ties. Fill out panelboard's circuit directory card upon completion of installation work. Utilize actual final building room numbers, not architectural numbers used on drawings. Identify individual lighting circuits and individual receptacle circuits by room served. Label circuit breakers to identify location of subpanel or equipment supplied using room numbers and equipment names. Include room number with equipment circuit designations. All directories to be typewritten.

END OF SECTION 262416

SECTION 262726 - WIRING DEVICES**PART 1 – GENERAL****1.1 RELATED DOCUMENTS**

- A. Drawings and general provisions of Contract, including General and Supplementary Conditions and Division-1 Specification sections, apply to work of this section.
- B. This section is a Division-26 Basic Materials and Methods section, and is part of each Division-26 section making reference to wiring devices specified herein.

1.2 DESCRIPTION OF WORK:

- A. The extent of wiring device work is indicated by drawings and schedules. Wiring devices are defined as single discrete units of electrical distribution systems that are intended to carry but not utilize electric energy.
- B. Types of electrical wiring devices in this section include the following:
 - 1. Receptacles
 - 2. Switches
 - 3. Timer Switches
 - 4. 0-10V & ELV LED LAMP DIMMERS
 - 5. Cord caps
 - 6. Cord connectors

1.3 QUALITY ASSURANCE:

- A. Comply with NEC and NEMA standards as applicable to construction and installation of electrical wiring devices. Provide electrical wiring devices that have been UL listed and labeled.

1.4 SUBMITTALS: Refer to Section 26 0502 for requirements.**PART 2 - PRODUCTS****2.1 FABRICATED WIRING DEVICES:**

- A. GENERAL:
 - 1. Provide factory-fabricated wiring devices, in types, and electrical ratings for applications indicated and complying with NEMA Stds. Pub No. WD 1.
- B. Provide PlugTail only wiring devices (of proper voltage rating) as follows:

	<u>RECEPTACLE</u>	<u>SWITCHES</u>			
<u>MFGR</u>		<u>1-POLE</u>	<u>3-WAY</u>	<u>4-WAY</u>	<u>W-PILOT</u>
Hubbell	HBL 5352	HBL 1221	HBL 1223	HBL 1224	HBL 1221-PL
Bryant	5352	1221	1223	1224	1221-PL
Pass Seymour	5352	20AC1	20AC3	20AC4	20AC1-RPL
Leviton	5362	1221	1223	1224	
Cooper	5352	1221	1273	1224	1221-PL

C. Provide devices in colors selected by Architect. Provide red devices on all emergency circuits.

A. GROUND-FAULT INTERRUPTER:

1. Provide general-duty, duplex receptacle, ground-fault circuit interrupters; feed-thru types, capable of protecting connected downstream receptacles on single circuit; grounding type UL-rated Class A, Group A, 20-amperes rating; 120-volts, 60 Hz; with solid-state ground-fault sensing and signaling; with 5 milliampere ground-fault trip level; color as selected by Architect. Provide Hospital grade where required elsewhere by specification or drawings. Provide units of one of the following:
 - a. P&S/Sierra
 - b. Hubbell
 - c. Leviton
 - d. Square D

B. USB RECEPTACLE

1. Provide duplex receptacle with two (2) USB 3.0 amps, 5VDC, 2.0 Type A charging ports.
2. Provide products of one of the following:
 - a. Bryant – USB20-X
 - b. Cooper – TR7736-X
 - c. Hubbell – USB20X2-X
 - d. Legrand – TR5362USB-X
 - e. Leviton – T5832-X

C. WEATHER-RESISTANT RECEPTACLES

1. Provide weather-resistant receptacles in outdoor locations such as under roofed open porches, canopies, marquees, etc.
2. Provide products of one of the following:
 - a. Pass & Seymour 2095TRWRXXX.
 - b. Hubbell GFTR20XX

D. CORD CAPS AND CONNECTORS:

1. Provide 3, 4 and 5-wire grounding, cap plugs, and connectors of ampere and voltage rating required, for final equipment, and as indicated otherwise on drawings.
2. Provide products of one of the following:
 - a. Cooper
 - b. General Electric
 - c. Hubbell
 - d. Leviton
 - e. P&S

E. TIMER SWITCH:

1. Provide a timer switch with the following features and functionalities. Provide switch that mounts in a standard wall box. Provide a Decora style cover plate that matches the other switches on the project. Provide color of switch chosen by Architect.
 - a. Provide Digital time switches that automatically turn lights off after a preset time. User programmable wall switch for astronomical and scheduled control. Electroluminescent back-lit LCD shows timer countdown. Compatible with all electronic ballasts, ELV, MLV, LED, and motor loads.
 - i. Wattstopper TS-400: 120/277VAC; 50/60 Hz
 - ii. Greengate
 - b. Provide Astronomical time switches that automatically turns lighting or other loads on and off according to user programming. Time-out settings range shall range from 5 minutes to 12 hours for flexibility. Electroluminescent back-lit LCD shows timer countdown. Compatible with all electronic ballasts, ELV, MLV, LED, and motor loads. Program schedule per the owner's requirements.
 - i. Wattstopper RT-200: 120/277VAC; 50/60 Hz

F. 0-10V & ELV LED LAMP DIMMERS:

1. Provide single-pole, semi-conductor modular type 0-10V control for 0-10V fluorescent ballasts/LED drivers & 3-wire fluorescent ballast/LED driver dimmers for fixtures; 60 hertz, with wattage and voltage as indicated, continuously adjustable slider control, and with electromagnetic filters to reduce noise and interference to minimum. Construct with continuously adjustable trim potentiometer for adjustment of low end dimming. Dimmer shall match lamp/ballast combination. Color as selected by Architect. Provide devices manufactured by one of the following:
 - a. Pass & Seymour (Titan Series)
 - b. Wattstopper – PW-311 Series
 - c. Lutron (Nova Series)
 - d. Lutron (Diva Series)

2.2 WIRING DEVICE ACCESSORIES:

G. WALL PLATES:

1. Provide stainless steel coverplates in all finished areas. Provide galvanized steel plates in unfinished areas. Provide blank coverplates for all empty outlet boxes.

H. WEATHER-PROTECTING DEVICE ENCLOSURES:

1. Where required for compliance with NEC 406-8 (receptacles installed outdoors for use other than with portable tools or equipment), provide weather-tight device covers that provide complete protection with the cord and cap inserted into the wiring device. Provide units that mount on either single or double gang devices.
2. Provide products of one of the following for In Box Horizontal for brick and cast stone:
 - a. Arlington Industries
 - i. DSHB1C Clear Cover
 - ii. DSHB1W White Cover
 - iii. DSHB1BR Brown Cover
 - iv. DSHB1BRC Brown Clear Cover
3. Provide products of one of the following for In Box Vertical or Horizontal for Stucco and Metal Sidings:
 - a. Arlington Industries
 - i. DSBVM1C Clear Cover
 - ii. DSBVM1W White Cover
 - iii. DSBHM1C Clear Cover
 - iv. DSBHM1W White Cover
4. Provide products of one of the following for roof mounted installations:
 - a. Intermatic WP1020 or WP1030
 - b. P&S WIUC10C or WIUC20c

PART 3 – EXECUTION

3.1 GENERAL

- A. Install wiring devices as indicated, in compliance with manufacturer's written instructions, applicable requirements of NEC and NECA's "Standard of Installation" and in accordance with recognized industry practices to fulfill project requirements.
- B. Coordinate with other work, including painting, electrical box and wiring work, as necessary to interface installation of wiring devices with other work. Install devices in boxes such that front of device is flush and square with coverplate. Drawings are small scale and, unless dimensioned, indicate approximate locations only of outlets, devices, equipment, etc. Locate outlets and apparatus symmetrically on floors, walls and ceilings where not dimensioned and coordinate with other work. Verify all dimensioned items on job site. Consult architectural cabinet, millwork, and equipment shop drawings before beginning rough-in of electrical work. Adjust locations of all electrical outlets as required to accommodate work in area, and to avoid conflicts with wainscoat, back splash, tackboards, and other items.

- C. Provide receptacles in surface raceway at 12" on center unless indicated otherwise.
- D. Install wiring devices only in electrical boxes that are clean; free from excess building materials, dirt, and debris.
- E. Install blank plates on all boxes without devices.
- F. Delay installation of wiring devices until wiring work and painting is completed. Provide separate neutral conductor from panel to each GFI receptacle.
- G. Install GFI receptacles for all receptacles installed in the following locations:
 - 1. Restrooms, locker rooms, kitchens, within 6 feet of any sink, or when serving vending machines and electric drinking fountains.
 - 2. Indoor wet locations, non-dwelling garages, elevator rooms and pits.
 - 3. Outdoors, and on rooftops.
 - 4. Dwelling unit garages, crawlspaces and unfinished basements, accessory buildings, boathouses, and receptacles for boat hoists.
- H. Where light switches or wall box dimmers are specified, provide a separate neutral for each phase of the branch circuits that switches or dimmers are connected.
- I. Electrical Identification: Refer to Section 260553 for requirements.

3.2 PROTECTION OF WALL PLATES AND RECEPTACLES:

- A. At time of substantial completion, replace those items, that have been damaged, including those stained, burned and scored.

3.3 GROUNDING:

- A. Provide electrically continuous, tight grounding connections for wiring devices, unless otherwise indicated.

3.4 TESTING:

- A. Prior to energizing circuitry, test wiring devices for electrical continuity and proper polarity connections. After energizing circuitry, test wiring devices to demonstrate compliance with requirements.

END OF SECTION 262726

BLANK PAGE

SECTION 262815 - OVERCURRENT PROTECTIVE DEVICES**PART 1 – GENERAL****1.1 RELATED DOCUMENTS:**

- A. Drawings and general provisions of Contract, including General and Supplementary Conditions and Division-1 Specification sections, apply to work of this section.
- B. This section is a Division-26 Basic Materials and Methods section, and is part of each Division-26 section making reference to overcurrent protective devices specified herein.

1.2 DESCRIPTION OF WORK:

- A. Extent of overcurrent protective device work is indicated by drawings and schedules and specified herein. Overcurrent protective devices specified herein are for installation as individual components in separate enclosures; and for installation as integral components of switchboard and panelboards. See Section 262413, Switchgear and Switchboards, and Section 262416, Panelboards.
- B. Types of overcurrent protective devices in this section include the following for operation at 600 Volts and below:
 - 1. Molded case thermal circuit breakers
 - 2. Molded case solid-state circuit breakers
 - 3. Fusible switches
 - 4. Fuses
- C. Refer to other Division-26 sections for cable/wire and connector work required in conjunction with overcurrent protective devices.

1.3 QUALITY ASSURANCE

- A. Comply with NEC requirements and NEMA and ANSI standards as applicable to construction and installation of overcurrent devices.

1.4 SUBMITTALS: Refer to Section 26 0503 for requirements.**PART 2 – PRODUCTS****2.1 ACCEPTABLE MANUFACTURERS:**

- A. Subject to compliance with requirements, provide products of one of the following (main and branch device manufacturer must be same as panelboard and/or switchboard manufacturer):
- B. CIRCUIT BREAKERS AND FUSIBLE SWITCHES:
 - 1. Cutler Hammer Products, Eaton Corp.
 - 2. General Electric Co.
 - 3. Square D Co.
 - 4. Siemens Energy and Automation
- C. BOLTED PRESSURE SWITCHES:

1. Bolt Switch Co.
2. General Electric Co. (HPC; High Pressure Contact Switches)
3. Pringle Switch Co.
4. Square D Co.

D. MOLDED CASE THERMAL TRIP CIRCUIT BREAKERS:

1. Provide factory-assembled, molded case circuit breaker for power distribution panelboards and switchboards; and for individual mounting, as indicated. Provide breakers of amperage, voltage, and RMS interrupting rating shown, with permanent thermal trip and adjustable instantaneous magnetic trip in each pole. Series rated systems are not acceptable. Construct with overcenter, trip-free, toggle type operating mechanisms with quick-make, quick-break action and positive handle indication. Construct breakers for mounting and operating in any physical position and in an ambient temperature of 40 degrees C. Provide with mechanical screw type removable connector lugs, AL/CU rated, of proper size to accommodate conductors specified.
2. Circuit breakers 15 amps through 399 amps shall be molded case thermal trip circuit breakers.

E. MOLDED CASE SOLID-STATE CIRCUIT BREAKERS:

1. Provide factory-assembled, molded case solid-state circuit breakers for power distribution switchgear and switchboards. Provide breakers of amperage, voltage and RMS interrupting rating shown, and with solid-state trip mechanisms. Breakers shall be UL listed for application at 100% of their continuous ampere rating.
2. Circuit breakers 400 amps through 1199 amps shall be molded case solid-state circuit breakers.
3. Solid-state trip mechanisms shall have the following functions: Adjustable long time ampere rating; adjustable long time delay; adjustable short time pick up; adjustable short time delay and adjustable instantaneous pick up.

F. FUSIBLE SWITCHES:

1. Provide factory-assembled fusible switch units for power distribution panelboards and switchboards, and individual mounting as indicated. Provide switch units of amperage, voltage, and RMS interrupting rating as shown, with quick-make, quick-break mechanisms, visible blades and dual horsepower ratings. Series rated systems are not acceptable. Equip with lockable handles with on-off indication. Interlock switch covers and handles to prevent opening in "ON" position. Provide switch with Class R rejection fuse clip kits. Provide AL/CU rated lugs of proper size to accommodate conductors specified.

G. BOLTED PRESSURE SWITCHES:

1. Provide factory-assembled fusible bolted pressure contact type switches of amperage, voltage and RMS interrupting ratings shown. Equip switches with quick-make, quick-break mechanisms with electric capacitor operated trip. Provide Buss KAZ signal activating fuses open. Provide "blown fuse protection" in HPC switches. Provide AL/CU rated lugs of proper size to accommodate conductors specified.

2.2 FUSES

- A. GENERAL: Except as otherwise indicated, provided fuses of type, sizes and ratings and electrical characteristics of a single manufacturer as follows. Provide fuses labeled UL

- Class L or UL Class R, current limiting and rated for up to 200,000 amperes. Provide Buss KAZ signal activating fuses where required elsewhere in specification.
- B. Where fuses are shown feeding individual or groups of equipment items, comply with manufacturer's recommendation for fusing; adjust fuse size and type as necessary to comply with manufacturer's recommendation.
 - C. Provide and install spare fuse cabinet in main electrical room.
 - D. MAIN SERVICE AND FEEDER CIRCUITS: For fuse ratings over 600 amperes provide UL Class L Fuses (KRP-C, or A4BQ or LCL or KLPC). For fuse ratings up to 600 amperes, provide UL Class RK1 (KTN-R, KTS-R or A2K-R, A6K-R or NCCR, SCLR or KLN-R, KLS-R). If fuse directly feeds motors, transformers or other inductive load provide UL RK5 time delay (FRN-R, FRS-R or TR-R, TRS-R or ECN-R, ECS-R or FLN-R, FLS-R).
 - E. BRANCH CIRCUITS: For motor circuits, transformer circuits, or other inductive loads, provide UL Class RK5 (FRN-R, FRS-R or TR-R, TRS-R or ECN-R, ECN-S or FLN-R, FLS-A). For other circuits, provide UL Class RK1, (KTN-R, KTS-R OR A2K-R, A6K-R or NCLR, SCLR OR KLN-R, KLSR).
 - F. MANUFACTURER: Subject to compliance with requirements, provide fuses of one of the following:
 - 1. Bussman Mfg. Co.
 - 2. Mersen (Ferraz Shawmut)
 - 3. Reliance Fuse Div./Brush Fuse Inc.
 - 4. Littlefuse, Inc.

PART 3 – EXECUTION

3.1 INSTALLATION OF OVERCURRENT PROTECTIVE DEVICES:

- A. Install overcurrent protective devices as indicated, in accordance with the manufacturer's written instructions and with recognized industry practices to ensure that protective devices comply with requirements. Comply with NEC and NEMA standards for installation of overcurrent protective devices.
- B. Coordinate with work as necessary to interface installations of overcurrent protective devices with other work.
- C. Install fuses in overcurrent protective devices. For motor circuits, fuse sizes shown on drawings are for general guidance only. Size fuses in accordance with fuse manufacturer's recommendation for given motor nameplate ampere rating. Test operation. If nuisance tripping occurs, increase fuse size and disconnect device (if necessary) as required to provide nuisance free tripping. Adjust fuse size properly for ambient temperature, frequent starting and stopping of motor loads, and for loads with long start times. Include all costs in bid.
- D. After the switchgear is energized and just prior to Substantial Completion, the contractor shall ensure that the field-adjustable circuit breakers and solid-state circuit breakers and associated trip mechanisms have been set to the appropriate settings as recommended by the equipment Manufacturer (or as recommended by the electrical contractor's Protective Device Study if section 260573 has been included in the project). Time-current trip curves and trip setting information as was required in the Submittal portion of this specification shall be made available by the contractor at this time. Provide adjustments to circuit breakers and switchboard AIC ratings as deemed necessary by the analysis/report, with no additional cost to the Owner. Provide over current protection devices with larger frame sizes to ensure coordination has been achieved.

E. Electrical Identification: Refer to Section 260553 for requirements.

3.2 FIELD QUALITY CONTROL

A. Prior to energization of overcurrent protective devices, test devices for continuity of circuitry and for short-circuits. Correct malfunctioning units, and then demonstrate compliance with requirements.

END OF SECTION 262815

SECTION 262816 - MOTOR AND CIRCUIT DISCONNECTS**PART 1 – GENERAL****1.1 RELATED DOCUMENTS:**

- A. Drawings and general provisions of Contract, including General and Supplementary Conditions and Division-1 Specification sections, apply to work of this section.
- B. This section is a Division-26 Basic Materials and Methods section, and is part of each Division-26 section making reference to motor and circuit disconnect switches specified herein.

1.2 DESCRIPTION OF WORK:

- A. Extent of motor and circuit disconnect switch work is indicated by drawings and schedule. Work includes complete installations and electrical connections.

1.3 QUALITY ASSURANCE:

- A. Provide motor and circuit disconnect switches that have been UL listed and labeled. Comply with applicable requirements of NEMA Standards Pub. No. KS 1, and NEC.

1.4 SUBMITTALS: REFER TO Section 26 0503 for requirements.**PART 2 - PRODUCTS****2.1 ACCEPTABLE MANUFACTURERS:**

- A. MANUFACTURER: Subject to compliance with requirements, provide products of one of the following (for each type of switch):
 - 1. Cutler Hammer Products, Eaton Corp.
 - 2. Square D Company
 - 3. General Electric Company
 - 4. Siemens Energy & Automation, Inc.

2.2 FABRICATED SWITCHES:

- A. GENERAL: Provide disconnect and safety switches as indicated herein. Provide:
 - 1. General duty switches on 240 Volt rated circuits.
 - 2. Heavy duty switches on 480 volt rated circuits.
 - 3. HP rated switches on all motor circuits.
- B. GENERAL DUTY SWITCHES: Provide general-duty type, sheet-steel enclosed switches, fusible or non-fusible as indicated of types, sizes and electrical characteristics indicated; rated 240 volts, 60 hertz; incorporating spring assisted, quick-make, quick-break mechanisms. Provide single phase or three phase and with solid neutral as required by application. Equip with operating handle that is capable of being padlocked in OFF position. Provide NEMA 1 or NEMA 3R as required by application, unless noted. Provide fusible switches with Class R rejection fuse clip kits.
- C. HEAVY-DUTY SWITCHES: Provide heavy-duty type, sheet-steel enclosed safety

switches, fusible or non-fusible as indicated, of types, sizes and electrical characteristics indicated; rated 600 volts, 60 hertz; incorporating quick-make, quick-break type mechanisms. Provide single phase or 3 phase, and with solid neutral as required by application, Equip with operating handle that is capable of being padlocked in OFF position. Provide NEMA 1 or NEMA 3R as required by application unless noted. Provide fusible switches with Class R rejection fuse clip kits.

- D. FUSES: Refer to section 26 0503 for requirements.
- E. Electrical Identification: Refer to Section 260553 for requirements.

PART 3 - EXECUTION

3.1 INSTALLATION OF MOTOR AND CIRCUIT DISCONNECT SWITCHES:

- A. Install motor and circuit disconnect switches where indicated, complying with manufacturer's written instructions, applicable requirements of NEC, NEMA, and NECA's "Standard of Installation" and in accordance with recognized industry practices to ensure that products fulfill requirements.
- B. Coordinate motor and circuit disconnect switch installation work with electrical raceway and cable work, as necessary for proper interface.
- C. Install disconnect switches used with motor driven appliances, and motors and controllers within sight of controller position.
- D. For disconnect switches serving motors controlled by variable frequency drives, provide late-make, early-break auxiliary contacts on each disconnect switch. (Provide Heavy-Duty switch). Wire auxiliary contact to VFD safety contact, such that disconnecting the motor will shut down the drive first, and closing the switch will start the drive only after power is applied to the motor.
- E. For disconnect switches serving elevators with auxiliary power hydraulic units, provide auxiliary contacts on each disconnect switch. Wire auxiliary contact to auxiliary power such that disconnecting the motor will disconnect the auxiliary power.

END OF SECTION 262816

SECTION 262913 - MOTOR STARTERS**PART 1 – GENERAL****1.1 RELATED DOCUMENTS:**

- A. Drawings and general provisions of Contract, including General and Supplementary Conditions and Division-1 Specification sections, apply to work of this section.
- B. This section is a Division-26 Basic Materials and Methods section, and is part of Division-26 sections making reference to motor starters specified herein.

1.2 DESCRIPTION OF WORK:

- A. Extent of motor starter work is indicated by drawings and schedules.
- B. Types of motor starters in this section include the following:
 - 1. AC Fraction Horsepower Manual Starters
 - 2. AC Line Voltage Manual Starters
 - 3. AC Non-Reversing Magnetic Starters
 - 4. AC Combination Non-Reversing Magnetic Starters

1.3 QUALITY ASSURANCE:

- A. Comply with NEC and NEMA Standards as applicable to wiring methods, construction and installation of motor starters. Comply with applicable requirements of UL 508, "Electric Industrial Control Equipment", pertaining to electrical motor starters. Provide units that have been UL-listed and labeled.

1.4 SUBMITTALS: Refer to Section for requirements.**PART 2 - PRODUCTS****2.1 MANUFACTURER:**

- A. Subject to compliance with requirements, provide products of one of the following (for each type and rating of motor starter):
 - 1. Allen-Bradley Co.
 - 2. Appleton Electric Co.
 - 3. Crouse-Hinds Co.
 - 4. Eaton Corp., Cutler Hammer Products
 - 5. General Electric Co.
 - 6. Siemens Energy & Automation, Inc.
 - 7. Square D Co.
- B. MAINTENANCE STOCK, FUSES: Refer to Section for requirements.

2.2 MOTOR STARTERS:

- A. GENERAL: Except as otherwise indicated, provide motor starters and ancillary

components; of types, sizes, ratings and electrical characteristics indicated that comply with manufacturer's standard materials, design and construction in accordance with published information and as required for complete installations.

- B. THERMAL OVERLOAD UNITS: Provide thermal overload units, sized to actual running full load current, not to motor plate current. Size heaters for mechanical equipment after air and water balancing have been completed.
- C. AC FRACTIONAL HP MANUAL STARTERS (EQUAL TO SQUARE D CLASS 2510): Provide manual, single-phase, 1 and 2 pole, 300 volt AC max, fractional HP motor starters, of types, ratings and electrical characteristics indicated; equip with one piece thermal overload relay with field adjustment capability of plus or minus 10 percent of nominal overload heater rating; for protection of AC motors of 1 HP and less. (For manually controlled motors in excess of 1 HP, see Line Voltage Manual Starters specified herein). Provide starter with quick-make, quick-break trip free toggle mechanisms, green pilot lights, and with lock-off toggle operated handle. Mount surface units in NEMA 1 enclosures, unless noted otherwise. Provide NEMA 3R enclosure in exterior or damp location unless noted otherwise. Provide flush mounted units with coverplate to match wiring device coverplates.
- D. AC LINE VOLTAGE MANUAL STARTERS (EQUAL TO SQUARE D CLASS 2510): Provide line voltage manual starters, of types, ratings and electrical characteristics indicated; 2 or 3 pole, 600 volt AC max; equip with pushbutton operator, low voltage protection feature, and green pilot light. Provide starters with trip free mechanism such that contacts will open under load and remain open until thermal element has cooled, and unit is reset. Mount surface units in NEMA 1 enclosure, unless noted otherwise. Provide NEMA 3R enclosure in exterior or damp location, unless noted otherwise. Provide overlapping trim for flush mounted units.
- E. AC NON-REVERSING MAGNETIC STARTERS (EQUAL TO SQUARE D CLASS 8536): Provide line voltage magnetic starters, of types, ratings and electrical characteristics indicated; 2 or 3 pole, 600 volt max, with thermal overload protection in all phases and inherent under voltage release. Equip units with holding contact, 2 normally open, and 2 normally closed auxiliary contacts, unless noted otherwise. Provide fused control transformer in each starter and 120V control coil. Mount hand-off-auto switch, red pilot light, and reset button in face of enclosure. Provide NEMA 1 enclosure unless noted otherwise. Provide NEMA 3R enclosure in exterior or damp location, unless noted otherwise. Equip all spare starters complete with items as specified herein.
- F. AC COMBINATION NON-REVERSING MAGNETIC STARTERS (EQUAL TO SQUARE D CLASS 8539): Provide line voltage combination starters, of types, ratings and electrical characteristics indicated; 2 or 3 pole, 600 volts max with non-reversing magnetic starters as specified herein; in common cubicle or enclosure with motor circuit protector. Provide motor circuit protector, instantaneous trip circuit breaker as indicated and adjust to comply with manufacturer's recommendations. Mount hand-off-auto switch, red pilot light, and reset button in face of enclosure. Provide combination starters for individual mounting, or for group mounting in motor control center as indicated. Provide NEMA 3R enclosure in exterior or damp locations, unless noted otherwise. Provide NEMA 1 enclosures unless otherwise indicated.
- G. AC COMBINATION NON-REVERSING MAGNETIC STARTERS (EQUAL TO SQUARE D CLASS 8538): Provide line voltage combination starters, of types, ratings, and electrical characteristics; 2 or 3 pole, 600 volt maximum with non-reversing magnetic starters as specified herein; in common cubicle or enclosure with fusible disconnect switch. Provide quick-make, quick-break, disconnect for NEMA sizes 1, 2, 3, and 4; and visible blade, automatic circuit interrupters with push-to-trip feature and separate fuse clips for larger NEMA sizes. Fuse all starters with dual-element (time-delay) fuses equal to Bussman FRN/FRS-R. Equip disconnect switch with Class R rejection fuse kits. Mount hand-off-auto switch, red pilot light, and reset button in face of enclosure. Provide

combination starters for individual mounting, or for group mounting in motor control centers as indicated. Provide NEMA 1 enclosures unless otherwise indicated. Provide NEMA 3R enclosure in exterior or damp locations, unless noted otherwise.

PART 3 - EXECUTION

3.1 INSTALLATION OF MOTOR STARTERS:

- A. Install motor starters as indicated, in accordance with manufacturer's written instructions, applicable requirements of NEC, NEMA standards, and NECA's "Standards of Installation", and in compliance with recognized industry practices to ensure that products fulfill requirements.
- B. Install fuses in fusible disconnects, if any. Mount chart inside each starter indicating heater type, size, and ampere ratings available.
- C. Electrical Identification: Refer to Section 260553 for requirements.

3.2 ADJUST AND CLEAN:

- A. Inspect operating mechanisms for malfunctioning and, where necessary, adjust units for free mechanical movement.
- B. Touch-up scratched or marred surfaces to match original finish.

3.3 FIELD QUALITY CONTROL:

- A. Subsequent to wire/cable hook-up, energize motor starters and demonstrate functioning of equipment in accordance with requirements.

END OF SECTION 262913

SECTION 264119 - DEMOLITION**PART 1 – GENERAL****1.1 RELATED DOCUMENTS:**

- A. Drawings and general provisions of Contract, including General and Special Provisions, Division 1 and Division-2 Specification sections, apply to work of this section.
- B. This section is a Division-26 Basic Materials and Methods section, and is part of each Division-26 section making reference to demolition.

1.2 DESCRIPTION OF WORK:

- A. Extent of major items of demolition work is indicated by drawings. Other demolition work shall be performed as required to maintain system operation.
- B. The intent of the drawings is to indicate major items affected and not to show every device, outlet, fixture, etc. affected by demolition work.
- C. The drawings do not necessarily reflect as-built conditions. The contractor shall visit the jobsite prior to bidding to determine the overall scope of demolition work.
- D. Refer to sections of other Divisions for applicable requirements affecting demolition work.
- E. Refer to Section 260500 for requirements with regard to power outages affecting the operation of existing electrical systems.

1.3 QUALITY ASSURANCE:**A. NEC COMPLIANCE:**

- 1. Comply with applicable portions of NEC as to methods used for demolition work.

PART 2 - PRODUCTS (NOT USED)**PART 3 - EXECUTION****3.1 GENERAL:**

- A. Demolition work shall be laid out in advance to eliminate unnecessary cutting, drilling, channeling, etc. Where such cutting, drilling, or channeling becomes necessary, perform with care, use skilled mechanics of the trades involved. Repair damage to building and equipment. Cutting work of other Contractors shall be done only with the consent of that Contractor. Cutting of structural members shall not be permitted.

3.2 PATCHING AND REPAIR

- A. The Contractor is responsible for all demolition, patching and repair of all finished interior surfaces pertaining to the installation of this particular phase of work. All surfaces shall be finished (painted, etc.) to match the adjacent materials, finishes and colors.
- B. Hard surfaces: Whenever demolition or excavation is required for the installation of the electrical system, it shall be the responsibility of this contractor to make repairs and/or replacements of hard finish surfaces such as concrete, asphalt, roofing, etc.
- C. The method of patching and repair shall follow good construction practices and all finished surfaces shall match materials and finish wherein the demolition occurred.

3.3 EXISTING EQUIPMENT

- A. The following is a part of this project and all costs pertaining thereto shall be included in the base bid.
- B. The new electrical equipment and apparatus shall be coordinated and connected into the existing system as required. Auxiliary systems shall comply, unless otherwise specified.
- C. The existing electrical devices, conduit and/or equipment that for any reason obstructs construction shall be relocated. Provide conduit, wiring, junction boxes, etc. as required to extend existing circuits and systems to relocated devices or equipment.
- D. The new fixtures indicated for existing outlets shall be installed in accordance with the fixture specifications.
- E. When installing equipment in the existing building, it shall be concealed.
- F. All existing electrical equipment and systems in portions of the building not being remodeled shall be kept operational, in service and in working condition throughout the entire construction period. Restore any circuits and systems interrupted. Provide temporary panels, temporary wiring and conduit, etc. as required.
- G. Maintain circuit integrity and continuity of all existing circuits and systems that interfere with or are interrupted by remodel work unless those circuits are to be abandoned completely. Maintain all circuits and systems in operation during construction. Provide temporary panels, temporary wiring and conduit, etc. as required.
- H. Existing raceways may be used where possible in place, except as noted. All circuits, conduit and wire that are not used in the remodeled area shall be removed back to the panelboard, where it shall be labeled a spare with circuit number indicated. Re-used raceway shall meet all requirements for new installations.
- I. The existing light fixtures that are not used in the remodeled area shall be carefully removed, and turned over to the owner or properly disposed of. Those fixtures indicated for re-use shall be thoroughly cleaned, repaired as required, relamped and installed as indicated.
- J. Obtain permission from the Architect and Owner's representative before penetrating any ceiling, floor, and wall surfaces.
- K. Any and all equipment having electrical connections that require disconnecting and reconnection at the same or another location throughout the course of construction shall be included as part of this contract.

END OF SECTION 264119

SECTION 265100 - INTERIOR AND EXTERIOR BUILDING LIGHTING

PART 1 – GENERAL

1.1 RELATED DOCUMENTS:

- A. Drawings and general provisions of Contract, including General and Supplementary Conditions and Division-1 Specification sections, apply to work of this section.
- B. Division-26 Basic Materials and Methods sections apply to work specified in this section.

1.2 DESCRIPTION OF WORK:

- A. Types of lighting fixtures in this section are indicated by schedule and include the following:
 - 1. LED (Light Emitting Diode)

1.3 QUALITY ASSURANCE:

- A. Comply with NEC, NEMA and ANSI 132,1 as applicable to installation and construction of lighting fixtures. Provide lighting fixtures that have been UL-listed and labeled.
- B. Components and fixtures shall be listed and approved for the intended use by a National Recognized Testing Laboratory (NRTL) including: UL, ETL, and CSA or equivalent
- C. All led products shall comply with the latest version of Illuminating Engineer Society (IES) publications LM-79 and LM-80.

1.4 SUBMITTALS: Refer to Section 26 0502 for requirements.

PART 2 – PRODUCTS

2.1 ACCEPTABLE MANUFACTURERS:

- A. Subject to compliance with requirements, provide products of one of the following (for each type of fixture):
 - 1. LED:
 - a. Cree
 - b. Nichia
 - c. Samsung
 - d. Philips Lumiled
 - e. Osram
 - f. Xicato

2.2 INTERIOR AND EXTERIOR LIGHTING FIXTURES:

A. GENERAL:

- 1. Provide lighting fixtures, of sizes, types and ratings indicated complete with, but not necessarily limited to, housings, lamps, lamp holders, reflectors, ballasts, LED drivers, starters, and wiring. Label each fixture with manufacturer's name and catalog number. Provide all enclosed fixtures with positive latch

mechanisms; spring tension clips not acceptable. Provide all exterior fixtures with damp or wet location label as required by application.

B. SUPPORT REQUIREMENTS:

1. Provide all pendant and stem hung fixtures with flexible ball joint hangers at all points of support. Equip hooks used to hang fixtures with safety latches. Provide all detachable fixture parts, luminous ceiling accessories, louvers, diffusers, lenses, and reflectors with locking catches, screws, safety chain, or safety cable.

C. LIGHT EMITTING DIODE (LED) LUMINAIRES:

1. LED luminaires that can be serviced in place shall have a disconnecting means internal to the luminaires to disconnect simultaneously from the source of supply all conductors of the driver, including the grounded conductor. Disconnects shall not be required under the following exceptions:
 - a. Luminaires located in hazardous locations.
 - b. Luminaires used for egress lighting.
 - c. Cord-and-plug luminaires.
 - d. In industrial establishments with restricted public access where conditions of maintenance and supervision ensure that only qualified persons service the installation.
 - e. Where more than one luminaire is installed in a space and where disconnecting the supply conductors to the luminaire will not leave the space in total darkness.
 - f. Provide LED luminaires which are tested in accordance with IES LM-79, diodes tested in accordance with IES LM-80, and provide a minimum R9 rating of ≥ 50 (unless specified differently), a CRI rating of ≥ 80 and L70 (6K) = 50,000 hours (IES TM-21). Provide with 0-10V dimming drivers as standard.
 - g. The fixture manufacturer(s) shall warrant the luminaires, in their entirety, to be free from defects in material or workmanship for at least 5 years from date of manufacture. Provide warranty in accordance with other sections of this specification and include a certificate of warranty from the fixture manufacturer with extended warranty information and proper forms and procedure description.

D. DIFFUSERS:

1. Where plastic diffusers are specified, provide 100 percent virgin acrylic compound; minimum thickness, .125 inches.

PART 3 - EXECUTION

3.1 INSTALLATION OF LIGHTING FIXTURES

- A. Install lighting fixtures at locations and heights as indicated, in accordance with fixture manufacturer's written instructions, applicable requirements of NEC, NECA's "Standards of Installation", NEMA standards, and with recognized industry practices to ensure that lighting fixtures fulfill requirements.
- B. Coordinate with other work as appropriate to properly interface installation of lighting fixtures with other work. Consult architectural reflected ceiling plan for exact location of all lighting fixtures.

- C. Provide all necessary supports, brackets, and miscellaneous equipment for mounting of fixtures. Support all ceiling mounted fixtures from the building structure; independent of the ceiling system, unless noted. Support each recessed fixture (fluorescent incandescent, and/or HID) from the building structure with #12 ga. steel wire attached to each corner (in addition to supports normally provided for attachment to the ceiling system). Provide backing supports above (or behind) sheetrock, plaster and similar ceiling and wall materials. Support surface mounted ceiling fixtures from channel. Support ceiling mounted outlet boxes independent of the raceway system, and capable of supporting 200 pounds. Feed each recessed fixture directly from an outlet box with flex conduit as required; do not loop from fixture to fixture. See plans for additional details.
 - D. FIXTURE WHIPS:
 - 1. Provide each lay-in light fixture with at least 36" (Not to exceed 72") of 3/8" steel flexible conduit.
 - 2. Within spaces utilizing 0-10v control schemes ie: Room Controllers, the fixture whip shall be comprised of a MC-PCS Cable (see Section 26 0532 Conduit raceways) with at least 36" and not to exceed 72" in length located above removable grid ceilings.
 - E. Coordinate lighting in mechanical room with duct and equipment locations to avoid obstruction of illumination.
 - F. Provide gypsum board protection as required, (acceptable to fire official having jurisdiction) to ensure fire rating of each ceiling that the fixtures are installed in.
 - G. COORDINATION MEETINGS:
 - 1. Meet at least twice with the ceiling installer. Hold first meeting before submittal of shop drawings to coordinate each light fixture mounting condition with ceiling type. During second meeting, coordinate fixture layout in each area.
 - 2. Meet at least once with the mechanical installer prior to fabrication and installation of duct work. Coordinate depth and location of all fixtures and duct work in all areas.
 - H. ADJUST AND CLEAN:
 - 1. Clean lighting fixtures of dirt and debris upon completion of installation.
 - 2. Protect installed fixtures from damage during remainder of construction period. Repair all nicks and scratches to appearance of original finish.
- 3.2 FIELD QUALITY CONTROL:
- A. Upon completion of installation of lighting fixtures, and after building circuitry has been energized, apply electrical energy to demonstrate capability and compliance with requirements.
 - B. Where possible, correct malfunctioning units at site, then retest to demonstrate compliance; otherwise remove and replace with new units, and proceed with retesting.
 - C. At the time of Substantial Completion, replace lamps in interior lighting fixtures that are observed to be noticeably dimmed after the Contractor's use and testing, as judged by Architect/Engineer.
 - D. GROUNDING:
 - 1. Provide equipment grounding connections for each lighting fixture.

END OF SECTION 265100

SECTION 271500 - TELEPHONE/DATA SYSTEMS**PART 1 – GENERAL****1.1 SCOPE OF DOCUMENT:**

- A. The following are project specifications that all cabling systems must adhere to. These specifications apply to all installers (hereinafter referred to as “the Contractor”) for all sites, that require, standards-compliant structured cabling systems and shall be used for all the installation, testing, and acceptance of the information transport systems as described in the attached specifications. Prices quoted of the installation facilities shall be all-inclusive and represent a complete installation at such sites as prescribed in this specification and contract documents. The Contractor shall be solely responsible for all parts, labor, testing, acceptance and all other associated processes and physical apparatus necessary to turn-over a completed system fully warranted and operational for acceptance by the Customer. Final acceptance of the installation shall be in writing by the Architect and Engineer.
- B. In all instances where Standards are cited, it is assumed Installer will have familiarity with and implicitly follow the recommendations of the most current version of the Standard referenced at the time of installation. Compliance with most current Standards is the sole responsibility of the Contractor.

1.2 RELATED DOCUMENTS:

- A. Drawings and general provisions of Contract, including General and Supplementary Conditions and Division-1 Specification sections, apply to work of this section.
- B. Division-7 Firestopping, apply to work of this section.
- C. Division-26 Basic Materials and Methods sections apply to work specified in this section.

1.3 SCOPE OF WORK:

- A. The extent of telephone/data system work is indicated by drawings and is hereby defined to include, but not be limited to racks, cabinets, patch panels, cables, raceway, outlet boxes, device plates, backboard, and grounding. Contractor is responsible for installation of all specified and unspecified necessary and miscellaneous items required for delivery of a complete and functional data cabling and device system.
- B. Contractor shall provide complete cable and outlet system as indicated on the drawings and described herein. Work shall include all associated infrastructure transmission components and support appliances including, but not be limited to cable, jacks, terminal blocks, racks, cabinets, wire management, labeling, transient voltage surge suppression, patch cords, telecommunications grounding system and all terminations as specified herein.
- C. Contractor shall provide system testing as described herein using up-to-date and industry accepted Level IIIe test equipment appropriate to the types of links being tested and in accordance with the latest edition of IEC 61935-1. All testers used shall be factory calibrated within one year of use with references set daily prior to testing.
- D. All active equipment (electronics) will be owner furnished and owner installed.
- E. Contractor shall be solely responsible for all parts, labor, testing, documentation and all other associated processes and physical apparatus necessary to turn-over the completed system fully warranted and operational for acceptance by Owner and Engineer.

- F. Contractor shall provide all labor, materials, tools and equipment required for the complete installation of work called for in the Construction Documents.
- G. Copper solution must match optical fiber solution and be provided by the same manufacturer. No two separate warranties are acceptable for the copper connectivity and optical fiber connectivity.
- H. Contractor shall provide 1-1" EMT conduit from telecommunications outlet/connector to accessible ceiling space, then utilize non-continuous cable support devices to EF/ER/TR/TE.

1.4 CONTRACTOR QUALIFICATIONS

- A. The contractor shall be fully conversant and capable in the cabling of low voltage applications such as, but not limited to voice and data network systems. The Contractor shall at a minimum possess the following qualifications:
 - 1. **Must** have at a minimum (1) RCDD certified individual employed full time at the time of bidding and throughout entire project. **PROVIDE PROOF OF RCDD CERTIFICATION IMMEDIATELY UPON JOB AWARD.**
 - 2. Approved and certified by connectivity manufacturer. Provide proof of certification immediately upon job award.
 - 3. BICSI Certified Installers or equivalent.
 - 4. Possess those licenses/permits required to perform telecommunications installations in the specified jurisdiction.
 - 5. Have a minimum of 5 years in the communications structured cabling business and be able to provide three owner references for the type of installation described in this specification for projects within the last 18 months.
 - 6. Personnel trained in the installation of pathways and support for housing horizontal and backbone cabling.
 - 7. Personnel knowledgeable in local, state, province and national codes, and regulations. All work shall comply with the latest revision of the codes or regulations. When conflict exists between local or national codes or regulations, the most stringent codes or regulations shall be followed.
 - 8. Be factory certified by the manufacturer used in installation of all transmission components of all copper and fiber links and able to provide the manufacturer warranty.
 - 9. The following communications contractors are encouraged to bid on the project:
 - i. R & L networks

1.5 QUALITY ASSURANCE

- A. Required Pre-Telecommunications Construction Meeting with Communications Engineer: Electrical contractor/representative AND Communications Contractor will be required to attend a pre-communications construction meeting (approximately 30-60 minutes) with Communications representative in the electrical engineer's office prior to communications construction commencement. This meeting will address any questions on the part of the contractor and the expectations of the Engineer with regard to specifications, plans and site visits for both rough and finish electrical work.
- B. Owner IT Contact:
 - 1. Firstname Lastname, email address, phone number
- C. BNA IT Contact:

1. Josh Oakeson RCDD; josh@bnaconsulting.com, 801-532-2196
2. Son Nguyen; snguyen@bnaconsulting.com, 801-532-2196

1.6 APPLICABLE CODES AND STANDARDS

- A. Contractor is responsible for compliance with all applicable portions of the NEC code as to type of products used and installation of components. All materials used shall be products and materials that have been UL-listed and labeled. All installed products shall comply with applicable NEMA standards for low loss extended frequency cable.
- B. In addition, installation shall adhere to the following Standards:
1. ANSI/TIA-568-C.0 - Generic Telecommunications Cabling for Customer Premises, or most recent edition at the time of installation
 2. ANSI/TIA-568-C.1 - Commercial Building Telecommunications Cabling Standards, or most recent edition at the time of installation
 3. ANSI/TIA-568-C.2 - Balance Twisted Pair Communications and Components Standards, or most recent edition at the time of installation
 4. ANSI/TIA -942 -Telecommunications Infrastructure for Data Centers, or most recent edition at the time of installation
 5. TIA-569-B - Commercial Building Standard for Telecom Pathways and Spaces, or most recent edition at the time of installation
 6. ANSI/TIA-606-A - Administration Standard for the Telecommunications Infrastructure of Commercial Buildings, or most recent edition at the time of installation
 7. ANSI/NECA/BICSI-607 - Commercial Building Grounding/Bonding Requirements, or most recent edition at the time of installation
 8. ANSI/TIA 1152 - Testing of Copper Links
 9. BICSI Telecommunications Distribution Methods Manual, 13th edition or most recent edition at the time of installation.
 10. TIA 758-A - Customer owned Outside Plant Telecommunications Infrastructure Standard (2004), including all applicable addenda and the most recent revision at the time of installation.
 11. BICSI Information Transport Systems Installation Manual - 5th edition or most recent edition at the time of installation.
 12. ANSI/NFPA-70 - 2017 National Electrical Code, revision, or most recent revision at the time of installation.
 13. ANSI/IEEE C-2 - 2017 National Electrical Safety Code or most recent revision at the time of installation.
 14. OSHA Standards and Regulations All applicable
 15. Local Codes and Standards All applicable
- C. Note: Anywhere cabling standards conflict with electrical or safety codes, Contractor shall defer to NEC and any applicable local codes or ordinances, or default to the most stringent requirements listed by either. Knowledge and execution of applicable codes is the sole responsibility of the Installer. Any code violations shall be remedied at the Contractor's expense.

1.7 ACCEPTABLE MANUFACTURERS:

A. General:

1. Unapproved product substitutions are not allowed. Contractor wishing to substitute any products for those expressly specified shall submit three samples of the alternate product to Engineer no less than two weeks prior to the last addendum accompanied by all engineering documents, drawings and third party test data proving mechanical and transmission equivalency. Acceptance of substitutions shall be received from Engineer in writing. All unapproved substitutions installed shall be removed by Contractor who shall assume all costs for removal and replacement with approved products. Such costs shall include, but not be limited to labor, materials, as well as any penalties or fees for late completion.

B. APPROVED MANUFACTURERS:

1. Contractor shall select only one line item in the each section of Parts 2 and 3. Contractor shall NOT utilize multiple line items for the project within each Part. For example, if Hubbell Cable is selected to be used for the project, all copper cabling and connectivity shall be by Hubbell. No other manufacturer or combination of manufacturers may be used for the copper cabling or connectivity equipment.
2. Copper Cabling / Connectivity Approved Manufacturers:
 - a. Hubbell
3. Non-Cabling / Connectivity Approved Manufacturers:
 - a. Same manufacturer from Part 2.

1.8 SUBMITTALS: Refer to Section 26 0502 for requirements.

PART 2 - PRODUCTS

2.1 GENERAL:

- A. All products shall be in new condition and UL listed.
- B. Provide complete raceway, outlet boxes and miscellaneous items. All conduit utilized shall be EMT grade.
- C. Provide 5" x 2.875" (or 4-11/16" x 3.25" square) deep square outlet box at each outlet location with single gang plaster or tile ring. Provide wall board adapters / accessories as necessary.
 1. Approved solutions:
 - a. RANDL 5 Square Telecommunications Outlet Box Model TX-550-YY where "X" could be a bracket box and "YY" could be knockout arrangements.
 - b. Hubbell Large Capacity Wall Box Model HBL260. If a 2" knockout is required for installation purposes, provide this box.
- D. Communication grounding and bonding shall be constructed and installed to meet or exceed the requirements of the National Electrical Code (NEC), IEC 1000-5-2 and ANSI/J-STD--607-A throughout the entire grounding system.
- E. All termination hardware shall be rated to meet specified cabling specifications.

2.2 ENTRANCE FACILITY (EF) / EQUIPMENT ROOM (ER) / TELECOMMUNICATIONS ROOM (TR)

A. General:

1. Contractor shall be responsible for the adequate and appropriate design of all racking systems, paying particular attention to sizing of all cable management troughs and supports both horizontal and vertical installation of patch panels and wire management into rack.
2. Main Cross Connect (MC) / Horizontal Cross Connects (HC):
 - a. Floor Mounted Racks: use existing racks (See Plans for Locations):
 - b. Copper Patch Panels:
 - i. Provide flush mount patch panels of required number and size to accommodate shown telecommunications outlets on plans. (No horizontal cable managers are required)
 - ii. Size panels to provide minimum 25% spare capacity. Fill all available space in remaining patch panels so that panels are fully populated.
 - iii. Support Category 6 or higher applications.
 - iv. Shall accommodate 8-Pin 8-Contact (8P8C) ports.
 - v. Mount to standard EIA 19" rack.
 - vi. Each patch panel shall include mounted behind it one "towel rack" style cable support bar for each 24 connections that the Contractor shall dress cables using hook and loop type cable ties.
 - vii. Approved Equipment

48-Port Patch Panel Cat 6		
<u>Manufacturer</u>	<u>Model Name</u>	<u>Flat Patch Panel</u>
Hubbell		HP648

2.3 CABLING DISTRIBUTION SYSTEMS AND MISCELLANEOUS EQUIPMENT

A. General:

1. Provide plenum rated cable/connectors if required, cabling/connectors must be appropriate for the environment that it is installed in. Provide wet rated cable for all wet locations, including any conduit in or below slab on grade.
2. Contractor shall be responsible for sizing all pathways such that newly installed cable represents not more than a 35% fill as per manufacturer's directions. Overfilled pathways are the sole responsibility of the Contractor who shall remove and reinstall at Contractors expense.
3. Provide products rated for the environment that it is installed in (i.e. riser, plenum, outdoor). All cabling installed in wet locations (i.e. underground conduit, conduit in slab on grade) shall be listed for use in wet locations.

B. Horizontal Cabling Distribution System – Balanced Twisted Pair

1. General:

- a. Provide and install appropriate number of Category 6 horizontal cables, patch cables, work area cables, for all terminated data drops, between switches, etc. so that building-wide networking will be operational once all installation is complete.
2. Horizontal Cabling
- a. Provide Cat 6 UTP, min-compliant, 4-Pair 100Ω Balanced Twisted Pair Cable to all locations shown on plans.
 - b. Provide cabling rated for the environment that it is installed in (i.e. underground conduit, conduit in slab on grade). All cabling installed in wet locations shall be listed for use in wet locations.
 - c. Provide a minimum of (2) cables, unless otherwise noted, to each location shown on plans.
 - d. Horizontal cable shall be blue.
 - e. Approved Equipment

Cat 6		
<u>Manufacturer</u>	<u>Model</u>	<u>Plenum</u>
Hubbel		C6ESPB

- 3. Patch and Work Area Cables: Owner provided
- 4. Telecommunications Outlets/Connectors (See Plans for Locations):
 - a. Faceplates:
 - i. Provide modular type information outlets with sloped telephone jack or data outlet. Provide single gang faceplate kits to allow up to six data or voice jacks as shown on plans. Provide faceplate kits for wall outlets in colors and materials that match power wiring device plates. Provide faceplate kits that allow labeling schemes described herein. Faceplates shall accept STP, UTP, fiber optic or audio/video modules as an option.
 - ii. Blank off all unused ports.
 - iii. Color: Standard color as selected by owner/architect.
 - b. Connector:
 - i. Color: Standard color as selected by owner/architect.
 - c. Approved equipment

<u>Manufacturer</u>	<u>Model</u>	<u>Connector Cat 6</u>
Hubbell		HXJ6B

<u>Manufacturer</u>	<u>Model</u>	<u>Stainless Steel Faceplates</u>
Hubbell		

PART 3 – EXECUTION

3.1 GENERAL

- A. Prior to pathway rough-in, low voltage contractor shall meet with electrical contractor to review pathway installation requirements.
- B. Pathway Requirements:
 - 1. General:
 - a. All pathways shall be designed, constructed, grounded and installed in accordance with all recommendations delineated within TIA 569-B and Standard TIA 942.
 - b. Prior to placing any cable pathways or cable, the contractor shall survey the site to determine job conditions will not impose any obstructions that would interfere with the safe and satisfactory placement of the cables. Arrangements to remove any major obstructions not identified on plans need to be determined at that time with the Engineer.
 - c. Paint all electrical boxes and their covers for the telephone and data system green (Kwal Paint Java Green AC098N).
 - 2. Conduits:
 - a. For any interior/exterior conduit 4" and larger, provide (3) 1.25" plenum-rated corrugated innerducts.
 - b. Flexible conduit is not acceptable as cable tends to creep, shift, or have sheath damage.
 - c. Achieve the best direct route parallel with building lines with no single bend greater than 90 degrees or an aggregate of bends in excess of 180 degrees between pull points or pull boxes.
 - d. Conduit runs shall not have continuous sections longer than 100 feet without a pull box and may only be filled to 35% capacity.
 - e. Ream all conduit ends and fit with an insulated throat nylon bushing with non-indenter type malleable steel fittings to eliminate sharp edges.
 - f. Telecommunications conduits should not be routed over or adjacent to heat sources such as boilers, hot water lines, or steam lines. Neither should they be routed near large motors, generators, photocopy equipment, or electrical power cabling and transformers.
 - g. Conduits that enter an EF/ER/TR must terminate near the corners to allow for proper cable racking. Terminate these conduits as close as possible to the wall where the backboard is mounted to minimize the cable route.
 - h. Terminate conduits that protrude through the structural floor 1" to 3" above the surface within an EF/ER/TR.
 - i. After installation, conduits shall be clean, dry, unobstructed, capped for protection, labeled for identification, reamed and fitted with bushings.
 - j. A 200lb pull cord (nylon, 1/8" minimum) shall be installed in any empty conduit.

- k. When the number of conduits requires more than one row, restrict the number of rows to two wherever practicable.
3. Open Top Cable Support Requirements:
- a. Provide wide surface area open-top cable supports spaced 5 feet apart at the maximum to adequately support and distribute cable's weight. Follow manufacturer specifications for cable loading. Provide supports that have a galvanized finish with wide base specifically for telecommunications cabling.
 - b. Non-continuous cable supports shall provide a bearing surface of sufficient width to comply with required bend radii of high-performance cables
 - c. Non-continuous cable supports shall have flared edges to prevent damage while installing cables.
 - d. Multi-tiered non-continuous cable support assemblies shall be used where separate cabling compartments are required. Assemblies shall consist of a steel angled hanger bracket holding up to six non-continuous cable supports.
 - e. Approved Equipment
 - i. Erico Caddy-Cat HP
4. Pull Box Requirements:
- a. NEC sized pull boxes are not acceptable. Follow BICSI and EIA/TIA 569-B guidelines for pull box sizing.
 - b. Provide pull boxes in sections of conduit that are 100 feet or longer, contain more than two 90-degree bends, or contain a reverse bend.
 - c. Conduits that enter the pull box from opposite ends should be aligned.
 - d. Pull boxes shall have a length 12 times the diameter of the largest conduit.
 - e. All pull boxes must be accessible.
- C. Cabling System:
- 1. Follow T568B scheme for copper cabling terminations.
 - 2. Provide a minimum of one balanced twisted pair cable to each voice outlet and one balanced twisted pair cable to each data outlet shown on the drawings unless noted otherwise on the drawings.
 - 3. Provide a minimum 6" service loop in each communications system junction box for balanced twisted pair. Cables shall be coiled in the in-wall boxes if adequate space is present to house the cable coil without exceeding manufacturers bend radius.
 - 4. Provide a minimum 10' service loop in each EF/ER/TR/TE.
 - 5. Provide a minimum 2' service loop at each stub-up or at each transition from conduit to cable tray.
 - 6. Provide a 5' service loop in the ceiling before the conduit travels down the wall and terminates into the communications junction box.
 - 7. Provide modular jacks for each installed cable at outlets shown on drawings. Blank off all unused ports on faceplate.

8. Provide Velcro type ties for all cables and install in a neat and workmanlike manner. Where applicable, use plenum rated Velcro. Where cable is installed in cable tray, bundle a maximum of 25 cables in each Velcro tie. No zip ties are permitted whatsoever.
 9. The bending radius and pulling strength requirements of all horizontal cables shall be observed during handling and after installation. Use pulling compound as recommended by manufacturer.
 10. All horizontal cables, regardless of media type, shall not exceed 90 m (295 ft) from the telecommunications outlets in the work area to the horizontal cross connect.
 11. The combined length of all patch cords in the EF/ER/TR and the work area shall not exceed 10m (33 ft)
 12. No splices are allowed.
 13. In a false ceiling environment, a minimum of 3 inches shall be observed between cable supports and false ceiling. At no point shall cable(s) rest on acoustic ceiling grids or panels.
 14. Cable shall be installed above fire-sprinkler systems and shall not be attached to the system or any ancillary equipment or hardware. The cable system and support hardware shall be installed so that it does not obscure any valves, fire alarm conduit, boxes, or other control devices.
 15. Cables shall not be attached to ceiling grid seismic support wires or lighting fixture seismic support wires. Where support for horizontal cable is required, the contractor shall install appropriate carriers to support the cabling.
 16. Any cable damaged or exceeding recommended installation parameters during installation shall be replaced by the contractor prior to final acceptance at no cost to the Owner.
 17. Pulling tension for balanced twisted pair shall not exceed 25lbf and for optical fiber shall not exceed 50lbf.
 18. Pair untwist at the termination shall not exceed 0.125". The cable jacket shall be maintained as close as possible to the termination point.
 19. Cables shall be neatly bundled and dressed to their respective panels or blocks. Each panel or block shall be fed by an individual bundle separated and dressed back to the point of cable entrance into the rack or frame.
 20. Cable shall not be draped on, tied or otherwise secured to electrical conduit, plumbing, ventilation ductwork or any other equipment. Cable shall be secured to building supports or hangers or to additional blocks or anchors specifically installed for this purpose.
- D. Electromagnetic Compatibility:
1. General:
 - a. Do not install power feeders above or within the telecommunications room. Do not install telecommunications conduits above electrical panelboards, switchboards, transformers, motor control centers, etc.
 - b. Where telecommunication cable is installed in grounded, metallic conduit near power cables, the power cables shall be kept physically separated from telecommunications cables:
 - i. Circuits Under 5kVA: 2" minimum separation.

- ii. Circuits Over 5kVA: 6" minimum separation.
 - iii. Electrical motors/transformers: 48" minimum separation.
 - iv. Lighting ballasts: 6" minimum separation.
 - c. Where telecommunication cable is installed in cable tray or underground in non-metallic conduit near power cables, the power cables shall be kept physically separated from telecommunications cables by a minimum of 12"
- E. Firestopping and Smoke/Acoustical Pathways(See Also Division 7):
 - 1. Provide firestop/smoke barrier solution equivalent to the wall/ceiling/floor rating.
 - 2. Provide firestop labels next to each penetration with written date. Label both sides of the penetration.
 - 3. Firestop systems shall be UL Classified to ASTM E8124 (UL 1479). A drawing showing the proposed firestop system shall be provided to the Engineer prior to installing the Firestop system(s).
 - 4. Utilize firestop pass-through type devices for medium to large penetrations into fire walls/floors.
 - 5. Provide a minimum of (4) 4" trade size Hilti Speedsleeves (or STI EZPath) with at least one spare for each and every firewall penetration where cable tray meets the wall.
 - 6. Provide the following products:
 - a. Fire Rated; STI EZ-Path Fire-Rated Pathways Series (or Hilti Speed Sleeve CP 653 BA)
 - b. Smoke/Acoustical Rated; STI EZ-Path Smoke & Acoustical Pathway Series (or Hilti Smoke and Acoustic Sleeve CS-SL SA)
- F. Miscellaneous Equipment:
 - 1. Arrange all terminal blocks in a manner that allows natural wiring progression and minimizes crossing of wires.
 - 2. Provide patch cords and cross connect cables as necessary for a complete operational telephone and data network system. Consult with owner to determine any special needs such as dedicated phone lines.

PART 4 – LABELING

4.1 GENERAL

- A. The contractor shall develop and submit for approval a labeling system for the cable installation. The Owner will negotiate an appropriate labeling scheme with the successful contractor. At a minimum, the labeling system shall clearly identify all components of the system: racks, cables, panels and outlets. The labeling system shall designate the cables origin and destination and a unique identifier for the cable within the system. Racks and patch panels shall be labeled to identify the location within the cable system infrastructure. All labeling information shall be recorded on the as-built drawings and all test documents shall reflect the appropriate labeling scheme.
- B. All telecommunications spaces, pathways, cables, connecting hardware, equipment, racks, patch panels, outlet/connectors, and grounding system shall be labeled in accordance with TIA/EIA 606-A.
- C. All labels shall meet UL 969 requirements for legibility, defacement and adhesion

requirements. Handwritten, Ink, or Laser Printing labels are not allowed. Provide labels using thermal transfer print. Heat shrinking or wraparound labels are required, flag style labels are not allowed.

4.2 TELECOMMUNICATION PATHWAYS

- A. Identify each dedicated pathway (including inner ducts) for the voice and data system.
- B. Label pathways at regular intervals and wherever they are accessible.

4.3 TELECOMMUNICATION CABLES

- A. Identify cables at each end with a permanent label or physical/electronic tag.
 - 1. The same alphanumeric identifiers should be used at both ends of the cable.
 - 2. Identify cables at regular intervals throughout and wherever they are accessible.
 - 3. Cables shall be identified in accordance with the System Documentation Section of this specification and ANSI/TIA/EIA-606-A. The cable label shall be applied to the cable behind the faceplate that can be accessed by removing the cover plate and to the cable behind the patch panel on a section of cable that can be viewed without removing the bundle support ties. Cables labeled within the bundle where the label is obscured from view shall not be acceptable.

4.4 CONNECTING HARDWARE

- A. Identify connecting hardware items (termination blocks, cross-connects, racks, cabinets, patch panels, telecommunications outlet/connectors, ports) using alphanumeric identification such as the following three-level scheme:
 - 1. First level—Termination field or patch panel. Color-coding or other labeling should be used to uniquely identify each termination field (e.g., voice and data) on a common mechanical assembly.
 - 2. Second level—Terminal block within a given field or patch panel that could be a row of insulation displacement connectors (IDCs), optical fiber connectors, or modular jacks.
 - 3. Third level—Defines the individual position within a given terminal block or patch panel.

4.5 TELECOMMUNICATIONS GROUNDING SYSTEM

- A. Identify each telecommunications grounding bus bar (TGB) and telecommunications main grounding bus bar (TMGB).
- B. Identify each grounding conductor relating to the telecommunications system, including those connecting building steel, grounding electrodes, water pipes, and telecommunications structural components.

PART 5 - MISCELLANEOUS

5.1 TESTING:

- A. General
 - 1. Provide testing within 10 days of completion for all copper cable according to TIA/EIA standards and any other requirements of the manufacturer who will provide warranty.

2. Submit copy of current calibration of all testing equipment. Submit all test reports electronically to architect/engineer and include in O&M manuals to include test reports. Meter shall have been calibrated within the past 12 months.
 3. Correct any malfunctions. Contractor shall re-terminate/replace any cable, connection, or equipment found to be defective or non-compliant with these specifications and referenced standards.
 4. Invite Owner IT representative and Engineer to witness and/or review field testing. Notify five business days prior to commencing testing.
- B. Copper Cable
1. Utilize Level IIIe Tester to test all equipment and each outlet, horizontal cable, termination block, patch cords, etc. to verify compliance with requirements. Testing shall consist of industry accepted verification tests for the Category of cable installed and shall meet latest requirements of EIA/TIA cabling Standards.
 2. UTP Cable and Links: All UTP cabling channel must be tested at swept frequencies up to 250MHz for internal channel performance parameters as defined in IEEE 802.3an and ANSI/TIA/EIA-568C. Certifications shall include the following parameters for each pair of each cable installed:
 - a. Wire map (pin to pin connectivity)
 - b. Length
 - c. Insertion Loss
 - d. Near End Crosstalk (NEXT)
 - e. Attenuation to Crosstalk Ratio Far End (ACRF)
 - f. Return Loss
 - g. Propagation Delay
 - h. Delay Skew
 - i. DC Loop Resistance
 - j. DC Resistance Unbalance
 - k. Power Sum Near-End Crosstalk (PS-NEXT)
 - l. Attenuation to Crosstalk Ratio Near-End (ACR-N)
 - m. Power Sum Attenuation to Crosstalk Ratio Near-End (PS-ACR-N)
 - n. Attenuation to Crosstalk Ratio Far-End (ACR-F)
 - o. Power Sum Attenuation to Crosstalk Ratio Far-End (PS-ACR-F)
 - p. Transverse Conversion Loss (TCL)
 - q. Equal Level Transverse Conversion Transfer Loss (ELTCTL)
 3. All channels that fail testing parameters will be replaced at the Contractor's expense until all channels pass the performance parameters.

5.2 WARRANTY:

- A. Register installation with cable/connectivity manufacturer.
- B. Provide and submit all test results to owner, engineer, and manufacturer and meet all other manufacturer requirements in order to provide minimum 20-year extended product link warranty for complete cabling/connectivity installation, including all copper utilized on the entire channel. The channel warranty shall be provided by the connectivity

manufacturer. Include replacement material and installation for any defective product.

5.3 OPERATING AND MAINTENANCE MANUALS: Refer to Section 26 0502 for requirements.

5.4 TRAINING:

A. Provide four hours training on the operation and installation of the structured cabling system at job site, at no cost to owner.

5.5 RECORD DRAWINGS: Refer to Section 26 0502 for requirements.

END OF SECTION 271500

BLANK PAGE

SECTION 283111 - FIRE ALARM AND DETECTION SYSTEM

PART 1 - GENERAL

1.1 RELATED DOCUMENTS:

- A. Drawings and general provisions of Contract, including General and Supplementary Conditions and Division-1 Specification sections, apply to work of this section.
- B. Division-26 Basic Materials and Methods sections apply to work specified in this section.

1.2 DESCRIPTION OF WORK:

- A. Provide new addressable fire alarm and detection system devices as required.
 - 1. Provide NAC/booster panels as needed throughout the project.
- B. Provide new duct smoke detectors and fan relays at all fan units 2000 CFM and over. Shut down all supply and return fans upon a general alarm signal.
- C. Install all wiring in steel conduit (3/4" minimum). All conduit runs shall form a complete loop from the fire alarm control panel.
- D. Comply with NEC as applicable to construction and installation of fire alarm and detection system components and accessories. Provide components and systems, which are UL-listed and labeled for fire alarm. Provide fire alarm and detection systems and accessories, which are FM approved. Comply with State and local requirements as applicable.
- E. The fire alarm system supplier shall be UL, UUJS Listed as a Local, Auxiliary, Remote Station, and Proprietary Signaling Services company. The UL Certification number shall be submitted with the bid documentation.
- F. The project shall be UL Certificated. Upon completion of the project, provide to the owner, a certificate from the UL Listed supplier with the project specific certificate. Certificate and number shall be documented and included as part of the closeout documentation.
- G. Comply with applicable provisions of current NFPA Standard 72 National Fire Alarm and Signaling Code (as applicable), local building codes, the most current adopted revision of the International Building Code (IBC), the International Fire Code (IFC), the International Mechanical Code (IMC), and meet requirements of local authorities having jurisdiction.
- H. Carefully review all Division 23 drawings for all fire/smoke dampers. Fire/smoke dampers are **NOT** shown on electrical plans. Electrical contractor is responsible for coordinating 120V emergency power to all dampers and providing fire alarm connections to each one. See mechanical drawings for all locations.
- I. Provide a fire alarm duct detector within 5-feet of any fire/smoke damper as required to comply with IMC 607.5.4.1. The duct detector shall be listed for the air velocity, temperature and humidity at the point where it is to be installed. A duct detector will not be required at a fire/smoke damper located on a corridor wall where the corridor has

smoke detection devices installed. For dampers installed within an un-ducted opening in a wall, a spot-type detector listed for releasing service shall be installed within 5-feet horizontally of the damper. Provide a fire alarm relay at each fire/smoke damper. Provide a test switch at each location where the damper is located above an inaccessible ceiling or is located more than 10 feet above the finished floor. Coordinate the location of test switches with owner/architect.

1.3 QUALITY ASSURANCE:

A. Installer:

1. Fire alarm equipment supplier shall be a Gamewell-FCI Platinum Level Distributor.
2. Integrating firm shall have worked satisfactorily for a minimum of (5) years of completing systems equal to this scope, quality, type and complexity.
3. Key personnel assigned to the project shall each have minimum of (10) years of experience in completing systems equal to this scope, quality, type and complexity.
4. Contractor shall be a factory authorized distributor of all equipment specified for the geographical area of the project.
5. Contractor shall maintain complete installation and service facilities for the duration of the project contract.
6. Contractor shall have current manufacturer certificates for all fire alarms systems and equipment listed within this specification.
7. Contractor shall be in good standing with owner based on previous projects.
8. Contractors that do not meet the above requirements cannot bid on this project.

B. All work shall be done by expert technicians qualified in the field with knowledge of specified systems. Workmanship shall comply with industry best practices concerning grounding, shielding, cable dressing, cable termination and equipment mounting.

C. PRE-APPROVED INSTALLERS:

1. Nelson Fire Systems
 - a. Ben Nelson, (801) 468-8300, 1481 S. Major St, Salt Lake City, UT 84115
2. Bids submitted by non-approved installers will not be accepted.
3. Bidders not pre-approved shall submit in writing the following for review at least (8) working days prior to bid:
 - a. List of qualifications including:
 - i. Industries certifications including manufacturers.
 - ii. Approved resale manufacturers.
 - b. Past and current projects within the last 5 years similar in scope and size.
 - c. (3) Different referrals from the owners of (3) different projects within the last 5 years.

1.4 SUBMITTALS: Refer to Section 26 0502 for requirements.

PART 2 - PRODUCTS

2.1 ACCEPTABLE MANUFACTURERS:

- A. MANUFACTURER: Provide fire alarm and detection system by Gamewell-FCI. Fire alarm equipment supplier shall be a Gamewell-FCI Platinum Level Distributor.

2.2 FIRE ALARM AND DETECTION SYSTEMS:

- A. GENERAL: Provide fire alarm system devices as shown and described herein. Include control units, power supplies, alarm initiating and indicating devices, conduit, wire, fittings and accessories required to provide a complete operating system. Enclose entire system in raceway. Provide basic wiring materials which comply with Division 26, Basic Materials and Methods Sections for raceways, conductors, boxes, fittings, supports, etc. Minimum wire size to be #14 AWG copper.
- B. SYSTEM OPERATION: Provide all conductors, raceway, equipment and labor to accomplish the following:
- C. Provide relays, monitor modules and connections as required at control panel of kitchen hood suppression system for initiation of alarm signal to fire alarm control panel. Connect hood suppression control panel to shunt trip breakers as required.
- D. Provide all required wiring from gas shut off valve to the kitchen hood suppression control panel. Make all connections to insure a properly operating system. Verify with Mechanical Contractor.

2.3 MONITOR MODULE:

- A. Remote identification module devices shall be attached to any single normally open initiating device (heat detector, waterflow switch, duct detectors, sprinkler, tamper switches, kitchen hood, pull station, carbon monoxide detector, etc.). The modules shall supply addressing and status information to the Fire Alarm Control Panel through the signaling line circuit.

2.4 CONTROL POINT MODULE:

- A. The control point module shall be connected to the same loop as the initiating devices, and shall provide two relay outputs (Form "C" 2 Amp @ 30 VDC, resistive only).
- B. This relay output shall be used to perform auxiliary functions.
- C. When the AOM is activated, the red "ACTIVE" LED shall be on solid. Under normal conditions, the green "ON LINE" LED shall flash.

2.5 MANUAL FIRE ALARM STATION:

- A. Provide red enclosure, manual fire alarm stations with the following features:
 1. suitable for semi-flush mounting.
 2. Addressable alarm type electrically compatible with system requirements.
 3. Double Action

2.6 PHOTOELECTRIC DETECTORS:

- A. All photoelectric detectors shall be capable of being replaced without disconnecting any wires or wire connectors from the base of the detector. Each detector shall be installed on a separate base. The detector base shall be capable of receiving a photoelectric, ionization, or electronic thermal detector. All photoelectric detectors shall be UL 268 listed. All detectors shall have two viewable LEDs to indicate the status of the device.

2.7 DUCT SMOKE DETECTORS:

- A. Provide photoelectric type with UL 268A listings. If duct smoke detector is not readily accessible, provide with a remote indicating light and remote test station.

2.8 AUDIOVISUAL ALARM HORNS:

- A. Provide audio-visual alarm horns with selectable multi-candela strobes (15/30/75/110 cd) and selectable horn (90 or 95 dba). Provide outdoor devices listed for exterior use. Provide white devices inside and red devices outside. Synchronize all strobes.

2.9 VISUAL ALARM STROBES:

- A. Provide visual alarm strobes with selectable multi-candela strobes (15/30/75/110 cd). Provide white devices. Synchronize all strobes.

2.10 AUXILIARY RELAY:

- A. Remote auxiliary relay boards shall be rated at 10 AMPS @ 120 VAC. A red LED shall light to indicate relay activation. All relays shall transfer on general alarm and latch on until reset. All relays shall be supervised. The control output provided can be used in conjunction with fire alarm applications (i.e. fan controls, dampers, doors, and any other general alarm control).

2.11 INITIATING MODULES:

- A. Provide style "6" initiating modules capable of receiving and annunciating an alarm from any detector, even with a single fault condition on any initiating circuit.
- B. Power all smoke detectors from the "Style 6" initiating loop wiring. For systems which power smoke detectors separately from the "Style 6" loop, provide monitoring for both the power source and the independent initiating wiring, so that complete trouble and alarm indication is achieved by loop. Provide capability to operate all smoke detectors, even with a single fault condition on the smoke detector power wiring.

2.12 SIGNALING MODULES:

- A. Provide signaling as required. Provide power adequate to sound all signaling devices concurrently. Provide supervised indicating circuits for polarized 24V D.C. alarm signaling devices.

2.13 SUPPLEMENTAL NOTIFICATION CIRCUITS:

- A. Provide supplementary notification appliance circuit panel(s) as required. The 'SNAC' shall be capable of supplying up to four Class A, Style Z notification appliance circuits. The panel shall contain its own battery charger, regulated power supply, and shall be supervised for ground fault, overcurrent, open circuits and low battery conditions.

Ground fault, battery and circuit trouble conditions shall transmit a trouble signal to the main fire alarm control panel.

Locate all Supplementary Notification Appliance Circuit power supplies as indicated on drawings.

2.14 SYSTEM CONFIGURATION PROGRAMMING:

- A. To help the owner in programming, system changes, and servicing, the fire alarm system shall have the following functions:
 - 1. The FACP shall be capable of an auto-configuration, which, via a password, all analog devices and panel modules are automatically programmed into the system. At this point the system will operate as a general alarm system without any other programming.
 - 2. If any two devices are addressed the same, the LED's on both devices will light steady and the panel will read "extra address with the address number".
 - 3. If any device is installed and not programmed into the system, the LED will light steady and the panel will read the same as above.

2.15 BATTERIES/POWER SUPPLIES:

- A. Provide additional standby batteries, as required, capable of operating fire alarm system for minimum of 24 hours, then operating all indicating units for at least five minutes. Locate batteries in fire alarm control unit, or in similar type enclosure located as directed. Provide all interconnecting wiring. Place batteries which vent hydrogen gas in separate enclosure. Provide 30 percent spare capacity.

PART 3 - EXECUTION

3.1 GENERAL REQUIREMENTS:

- A. Install fire alarm and detection systems as indicated, in accordance with equipment manufacturer's written instructions and complying with applicable portions of NEC and NECA's "standard of installation".
- B. Install wiring, raceways, and electrical boxes and fittings in accordance with Division 26 Basic Materials and Methods section, "Raceways", "Wires and Cables", and "Electrical Boxes and Fittings", and in accordance with other sections, as applicable. Label all junction boxes "F.A." and paint box and cover red, per Section 26 0553.
- C. All wire used on the fire alarm system shall be U.L. Listed as fire alarm protective signaling circuit cable per NEC, Article 760.
- D. If twisted or shielded wire is required or recommended by the manufacturer it must be used.
- E. Review proper installation procedure for each type of device with equipment supplier before installation.
- F. Provide Two (2) network IP addresses at the new fire alarm control unit for connection to the FocalPoint system. Coordinate with the district IT department for network connections.

- G. Coordinate the mechanical units that are protected by Carbon Monoxide Detectors and shut down the unit upon detection of CO. Locate the CO detector in the first room the mechanical unit serves. Verify exact requirements with the Fire Marshal.
- H. Label the end of wires in all boxes including panel, power supplies, pull boxes, etc.V
- I. Label circuit breaker feeding fire alarm panel: "Fire alarm circuit". Use plastic laminate label, white letters on red background.
- J. Where smoke or heat detectors are specified, install device a minimum of three feet from adjacent air supply diffusers to ensure proper operation of device.
- K. Refer to NFPA for spacing and exact placement of fire alarm devices.

3.2 GUARANTEE:

- A. Furnish a three-year guarantee for all equipment, materials and installation, including all labor, transportation, and equipment.
- B. Emergency Response. The fire alarm equipment supplier shall provide an emergency response within four hours of any reported system failure to resolve the problem on a continuous basis.

3.3 PRE-TEST:

- A. The contractor shall with a representative of the manufacturer conduct a test 3 days before the final test to verify operation of all devices. Any problems must be corrected before the final test.

3.4 FINAL TEST:

- A. Before the installation shall be considered completed and acceptable, a test on the system shall be performed as follows:
 - 1. The contractor's job foreman, a representative of the manufacturer, a representative of the owner, shall operate every building fire alarm device to ensure proper operation and correct annunciation at the control panel. Fan shutdown and door holder circuits shall operate.
 - 2. Conduct a full 24-hour test of battery operation. System shall be put on the batteries for a full 24 hours and all notification appliances shall be operational for a period of 5 minutes.
 - 3. The supervisory circuitry of the initiating and indicating circuits shall also be verified.
 - 4. Provide printout demonstrating successful performance of all devices.

3.5 LABELING:

- A. All devices shall be labeled with their appropriate address. The labels shall be 18 point pressure sensitive labels.

- B. All initiating devices shall be programmed to include the device address and a complete user text English location description, i.e. Device L4S76, Smoke Detector, 1st floor Rm.17.
- C. Label the end of all wires in all boxes including panels, power supplies, pull boxes, etc.

3.6 AS BUILT DRAWINGS:

- A. A complete set of CAD "as-built" drawings showing installed wiring, color coding, specific interconnections between all equipment, and internal wiring of the equipment shall be delivered to the owner upon completion of the system. Vendor shall not request drawings from the Engineer. Vendor shall request current architectural drawings from the Architect and include all cost with bid.
- B. A building map shall be supplied to the owner indicating the exact location of all devices along with the addresses of the individual devices. Install building fire alarm map adjacent to the fire alarm panel and all remote operating panels. Provide high quality plastic sign (map holder) with two layers. The back layer shall be painted black. The front layer shall be a clear center for viewing the CAD fire alarm drawing. The building map shall indicate the various devices by the use of different colors (minimum of five colors).
- C. Provide a CD to the Owner containing the information specified below. The CD shall include all information required to allow the Owner to change the fire alarm program themselves. The CD shall contain a minimum of the following:
 - 1. CAD drawing files of building fire alarm map
 - 2. CAD drawing files of as-built fire alarm components and point to point connections.
 - 3. General configuration programming.
 - 4. Job specific configuration programming.

3.7 OPERATING AND MAINTENANCE MANUALS:

- A. Operating and maintenance manuals shall be submitted prior to testing of the system. Manuals shall include all service, installation, and programming information.

3.8 TRAINING:

- A. Provide four (4) hours training on the operation and installation of fire alarm system, at job site, at no cost to owner.

END OF SECTION 283111

BLANK PAGE