

AM659

High Speed Automatic Plastic Strapping Machine

For all of your
General Packaging
Needs



Ideal for:



Totes, Cut
Paper, Boxes
and Cartons



Mail Trays



Linen/
Rags



Newspaper/
Magazines



Wood/
Lumber

Dynaric, Inc.



AUTOMATED EQUIPMENT SERVICE, INC.

MAIL PROCESSING SYSTEMS

(845) 452-2100

(518) 459-4545

(914) 478-2100

(607) 733-2108

info@AESMailPro.com

Making Your Strapping Job Easier

The AM659 is a high speed automatic heat seal strapping machine that is designed for ease of operation by equipment operators. It is capable of applying up to 50 straps/minute to a wide range of sizes and types of packages.

The AM659 can operate using 9mm and 12mm wide plastic strap. Because of its ability to use many sizes of strap the AM659 enables customers to choose the best Dynaric plastic strap for their budget and packaging requirements. The AM659 has many standard features that include automatic coil feed system, strap loop ejector, short feed detector, refeed system and precision electronic tension control. These user friendly features combine to increase strapping performance and reliability, as well as providing ease of operation for the equipment operator.

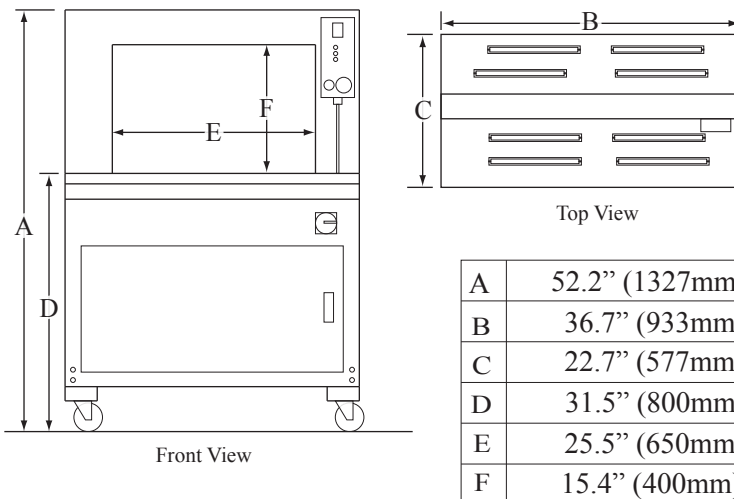

Arch Sizes Available

Height	Width						
	650	850	1050	1250	1450	1650	2650
400	•	•	•	•	•	•	•
600	•	•	•	•	•	•	•
800	•	•	•	•	•	•	•
1000	•	•	•	•	•	•	•
1200	•	•	•	•	•	•	•

- Dots in **Bold** are common arch sizes.
- Sizes not shown can be custom built in 200mm increments.

At A Glance

- Servo motors for precise performance and elimination of belts, clutches and pulleys.
- Wide range electronic tension control
- Adjustable strap heat seal dwell time for optimum seal joint efficiency
- Applies 50 straps/minute
- Automatic coil feed system for ease of start up
- End of strap sensor and strap loop ejector
- Strap re-feed system in case of a short feed
- Standard foot bar pedal activator and start cycle push button
- Standard arch sizes available 650mm wide x 400mm high and 650mm x 600mm high

Specifications

Cycle Time:	50 straps per minute
Tension Range:	2.2-121 lbs.
Strap Width:	Standard: 9mm or 12mm
Sealing Method:	Heating Element
Reel Inside Diameter:	200, 230, 280 mm (specified)
Power Supply:	110/220/230/240V, 50/60Hz, 1PH
Power Consumption:	0.5 kw
Standard Arch Size:	W 650 x H 400 mm
Table Height:	800mm
Layout Dimension:	L 933 x W 577 x H 1327 mm
Machine Weight:	573 lbs.

Personalize Your Packages



Personalize your plastic strapping. Dynaric's high quality printed plastic strapping can be custom printed with your company logo, name, information or message. Printed strapping is an economical way to identify special products, display company logo and information or for product security and more.

