



**PROUDLY**  
ASSEMBLED & TESTED



**IN THE USA**

# ***EAGLE SP11***

## ***SEMI-AUTOMATIC STRAPPING MACHINE***



***DUAL***  
***DIRECT-DRIVE***  
***MOTORS***  
24 VOLT

***"SILENT"***  
***OPERATION***

***SIMPLE DESIGN =***  
***LESS MAINTENANCE***



**AUTOMATED EQUIPMENT SERVICE, INC.**

MAIL PROCESSING SYSTEMS

(845) 452-2100 (518) 459-4545  
(914) 478-2100 (607) 733-2108

[info@AESMailPro.com](mailto:info@AESMailPro.com)



## Standard Features

- Dual direct-drive 24 volt motors
- "Silent" operation
- Quad locking casters
- Adjustable leg height
- Electronic tension control
- Stainless steel table top
- Safety switch
- Eco friendly

## Specifications

- Power requirement: 110VAC / 60Hz
- Strapping width: 6mm to 15mm (1/4" to 5/8")
- Core Size: 8x8 (standard)
- Tension: 0 to 110lbs
- Sealing method: Heat weld
- Machine weight: 149lbs

**\* 1-year parts warranty \***

## Dimensions

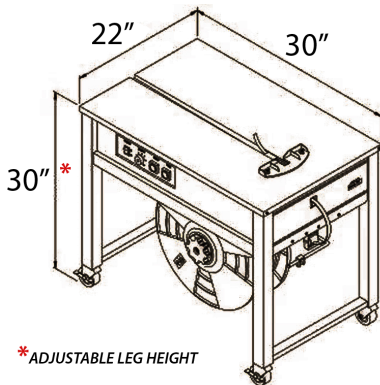

Eagle SP11

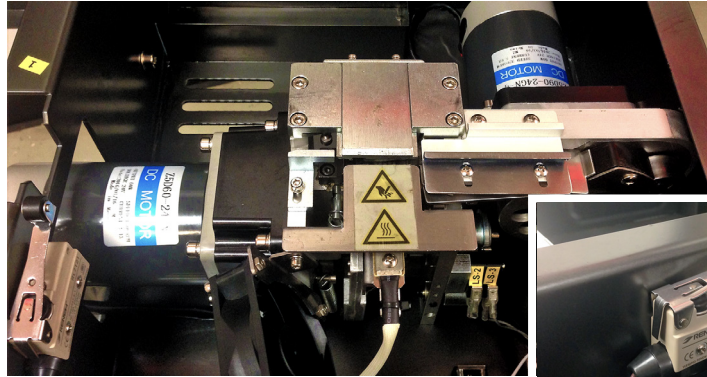

Dual Direct-Drive 24-Volt Motors



Safety Switch



Control Panel



Locking Casters



Adjustable Height

DISTRIBUTED BY



**AUTOMATED EQUIPMENT SERVICE, INC.**

MAIL PROCESSING SYSTEMS

(845) 452-2100

(518) 459-4545

(914) 478-2100

(607) 733-2108

[info@AESMailPro.com](mailto:info@AESMailPro.com)