



V-900IJ (Inkjet Series)

Overview

An economically priced continuous inkjet feeder for feeding flat and multi-thickness products consistently at high speeds into mail production streams, including inkjet and tabber systems. Feed a wide variety of flat and multi-thickness products including manuals, cards, envelopes, flat cartons, perfect bound magazines, saddle-stitched magazines, sheet paper, and much more.

Standard Features

- Long lasting natural gum rubber feed belts
- Independent side guide positioning
- Self-adjusting discharge hold down
- Patented product separator
- Suction cup mounting

Optional Features

- Cabinet Mounting Base

Applications (ask us about your application)

Addressing	Coding	Ink Jet Bases
Labeling	Printing	Scanning
Tabbing		

Products (ask us about your products)

Sheet Paper	C-Folds	Z-Folds
Manuals	Business Cards	Payment Booklets
Cardstock	Envelopes	Plastic Cards
Post Cards	Brochures	and more...

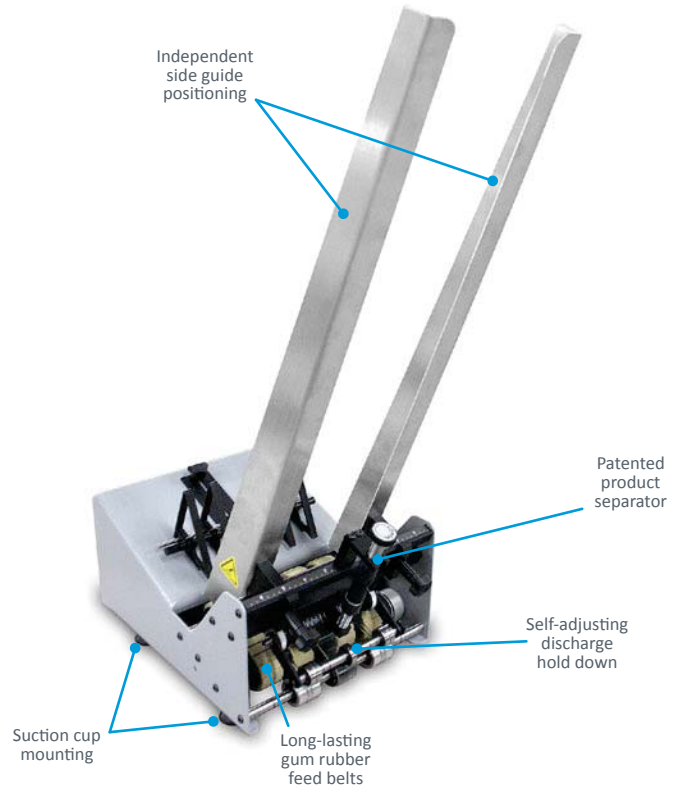

Specifications	
Maximum Product Size	9.25 W x 11 L in (235 x 279 mm)
Minimum Product Size	2.125 W x 2.25 L in (54 x 57 mm)
Min/Max Product Thickness	.003 - .250in (.076 - 6.35 mm)
Belt Speed	4800 in/min (121.9 m/min)
Utilities	115vac, 60Hz, 2.5A
Weight	Only 19 lbs. (8.62 kg)
Warranty	One year limited
<i>Other sizes and thickness capabilities available. Contact us for your application.</i>	



AUTOMATED EQUIPMENT SERVICE, INC.

MAIL PROCESSING SYSTEMS

(845) 452-2100 (518) 459-4545

(914) 478-2100 (607) 733-2108

info@AESMailPro.com

Footprint drawing available at:
www.streamfeeder.com/footprints.html
or scan the QR Code

