



RESTAURANT EQUIPMENT HAWAII

QUALITY COMMERCIAL EQUIPMENT FOR
RESTAURANTS & BARS

VISIT OUR ONLINE STORE FOR PRICING & INFORMATION ON
EQUIPMENT, FOOD TRUCKS & OUR COMMISARY KITCHEN

808-845-5052

SPECIAL FEATURES

- ALL STAINLESS STEEL TANK, DOOR, FRONT, TOP, LEDGE, AND HEADER; GALVANIZED STEEL SIDES
- EASY TO USE THERMOSTAT FOR ACCURATE AND ADJUSTABLE TEMPERATURE BETWEEN 200-400°F
- 40 LB. FRY POT, WITH AN EFFICIENT AND QUIET 3 TUBE BURNER SYSTEM, AND FULL PORT DRAIN
- TWO NICKEL CHROME WIRE MESH FRY BASKETS INCLUDED
- 3/4" GAS CONNECTION



Item Sku	Overall Oil Capacity	Exterior Dimensions	Tank/Pot Dimensions	Total BTU/HR	Power Type
FS-40-LP	40 LB.	15.5"x30.25"x47.125"	14"x14"	90,000	Natural Gas
FS-40-NG	40 LB.	15.5"x30.25"x47.125"	14"x14"	90,000	Liquid Propane

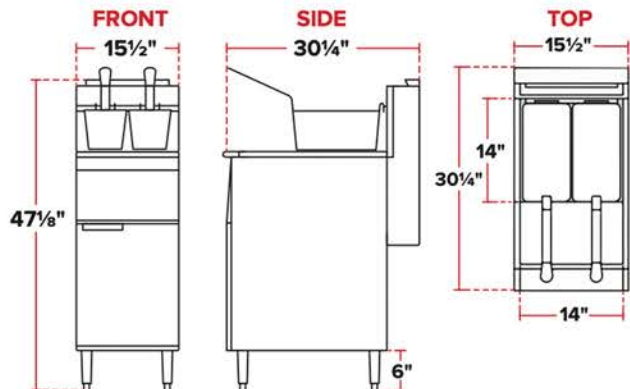

WARRANTY
RESIDENTIAL: REH ASSUMES NO LIABILITY FOR PARTS OR LABOR COVERAGE FOR COMPONENT FAILURE, FACTORY DEFECT OR ANY OTHER DAMAGES FOR UNITS INSTALLED IN NON-COMMERCIAL FOODSERVICE OR RESIDENTIAL APPLICATIONS.



PARTS & LABOR