



RESTAURANT EQUIPMENT HAWAII

QUALITY COMMERCIAL EQUIPMENT FOR
RESTAURANTS & BARS

VISIT OUR ONLINE STORE FOR PRICING & INFORMATION ON
EQUIPMENT, FOOD TRUCKS & OUR COMMISARY KITCHEN

808-845-5052

SPECIAL FEATURES

- ALL STAINLESS STEEL TANK, DOOR, FRONT, TOP, LEDGE, AND HEADER; GALVANIZED STEEL SIDES

- EASY TO USE THERMOSTAT FOR ACCURATE AND ADJUSTABLE TEMPERATURE BETWEEN 200-400°F

- 50 LB. FRY POT, WITH AN EFFICIENT AND QUIET 4 TUBE BURNER SYSTEM, AND FULL PORT DRAIN

- TWO NICKEL CHROME WIRE MESH FRY BASKETS INCLUDED

- 3/4" GAS CONNECTION



Item Sku	Overall Oil Capacity	Exterior Dimension	Tank/Pot Dimensions	Total BTU-HR	Power Type
FS-50-NG	50 LB.	15.5"x30.25"x47.125"	14"x14"	120,000	Natural Gas
FS-50-LP	50 LB.	15.5"x30.25"x47.125"	14"x14"	120,000	Liquid Propane

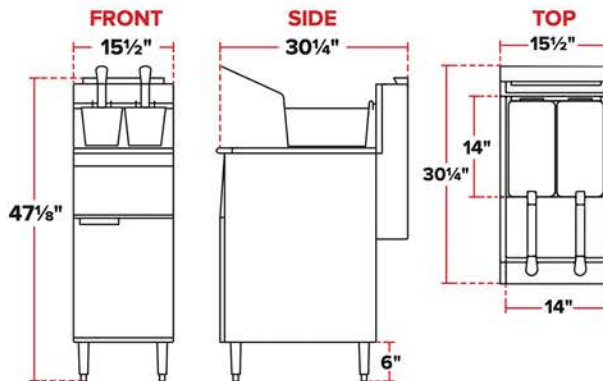

WARRANTY
RESIDENTIAL: REH ASSUMES NO LIABILITY FOR PARTS OR LABOR COVERAGE FOR COMPONENT FAILURE, FACTORY DEFECT OR ANY OTHER DAMAGES FOR UNITS INSTALLED IN NON-COMMERCIAL FOODSERVICE OR RESIDENTIAL APPLICATIONS.



PARTS & LABOR