



RESTAURANT EQUIPMENT HAWAII



CABINET CONSTRUCTION

HEAVY DUTY CONSTRUCTION INCLUDES 430 TYPE STAINLESS STEEL EXTERIOR WITH A 304 TYPE STAINLESS STEEL INTERIOR AND AN OVERALL 35 1/4" WORKING HEIGHT.

FULL LENGTH, 8" DEEP CUTTING BOARD FOR EASY PREP WORK.

FOAMED-IN-PLACE CFC- AND HCFC-FREE POLYURETHANE INSULATION ENHANCES THE STRUCTURAL INTEGRITY OF THE CABINET AND HELPS INCREASE ENERGY EFFICIENCY.

2 DOORS FEATURE EASY-TO-USE RECESSED HANDLES FOR QUICK INTERIOR ACCESS. DOOR STAYS OPEN PAST 90° FOR EASY LOADING, BUT WILL SELF-CLOSE UNDER 90° TO SAVE ENERGY.

REFRIGERATION SYSTEM

ENVIRONMENTALLY-SAFE R290 REFRIGERANT. REAR-MOUNTED CONDENSING UNIT POSITIONED FOR EASY MAINTENANCE.

SHELVING

2 EPOXY-COATED STEEL SHELVES INCLUDED. EACH ACCOMMODATES UP TO 90 LB.

MODEL FEATURES

PREPROGRAMMED DIGITAL CONTROLS. AUTO- DEFROST FUNCTION SIMPLIFIES MAINTENANCE AND SERVICE.

TOP PAN RAIL HOLDS UP TO (24) 1/6 SIZE, 6" DEEP FOOD PANS.

PAN RAIL IS AIR COOLED FROM THE BOTTOM.

STAINLESS STEEL SANDWICH PREP TABLE

KEEP INGREDIENTS WITHIN A SAFE TEMPERATURE RANGE IN A SLEEK, DURABLE, AND EASY-TO-CLEAN ENVIRONMENT

SPECIAL FEATURES

- ECO-FRIENDLY R290 HYDROCARBON REFRIGERANT
- TOP HOLDS UP TO (24) 1/6 SIZE, 6" DEEP FOOD PANS
- FULL LENGTH, 3/4" THICK, 8" DEEP CUTTING BOARD FOR EASY PREP WORK
- INSULATED LID HELPS MAINTAIN SAFE PRODUCT TEMPERATURES
- DOUBLE SELF-CLOSING SWING DOORS WITH RECESSED HANDLES
- 2 EPOXY COATED WIRE SHELVES
- 430 TYPE STAINLESS STEEL EXTERIOR AND 304 TYPE STAINLESS STEEL INTERIOR
- DIGITAL TEMPERATURE CONTROLS HOLD AT 33-40° F
- 115V, 1/4 HP
- PAN RAIL IS AIR COOLED FROM THE BOTTOM



PARTS & LABOR



COMPRESSOR

WARRANTY
RESIDENTIAL: REH ASSUMES NO LIABILITY FOR PARTS OR LABOR COVERAGE FOR COMPONENT FAILURE, FACTORY DEFECT OR ANY OTHER DAMAGES FOR UNITS INSTALLED IN NON-COMMERCIAL FOODSERVICE OR RESIDENTIAL APPLICATIONS.



RESTAURANT EQUIPMENT HAWAII

QUALITY COMMERCIAL EQUIPMENT FOR
RESTAURANTS & BARS

VISIT OUR ONLINE STORE FOR PRICING & INFORMATION ON
EQUIPMENT, FOOD TRUCKS & OUR COMMISARY KITCHEN

808-845-5052

TECHNICAL DATA

DIMENSIONS

EXTERIOR DIMENSIONS	60 1/4"W x 35"D x 45 7/8"H
INTERIOR DIMENSIONS	56 1/4"W x 23 3/4"D x 23 1/2"H
NET VOLUME	15 CU. FT.
NET WEIGHT	385 LB.
GROSS WEIGHT	451 LB.
PACKAGING DIMENSIONS	64 1/2"W x 39 1/4"D x 49"H

COOLING

TEMPERATURE RANGE	33°F-40°F
REFRIGERANT	R290
MAX. AMBIENT TEMPERATURE	90°F
DEFROSTING	AUTOMATIC
TEMPERATURE CONTROLLER	DIGITAL
HORSEPOWER	1/4

CONSTRUCTION

EXTERIOR DIMENSIONS	430 STAINLESS STEEL
INTERIOR MATERIAL	304 STAINLESS STEEL
INSULATION MATERIAL	FOAMED-IN-PLACE POLYURETHANE
SHELF SIZE	(2) 27 9/16" x 17 1/16"
SHELF MATERIAL	EPOXY-COATED STEEL
SHELF LOAD CAPACITY	90 LB.

ELECTRICAL

VOLTAGE	115
AMPS	7.8
HZ	60
PHASE	1
PLUG TYPE	NEMA 5-15P
ELECTRICAL CORD LENGTH	84"

PLAN VIEW

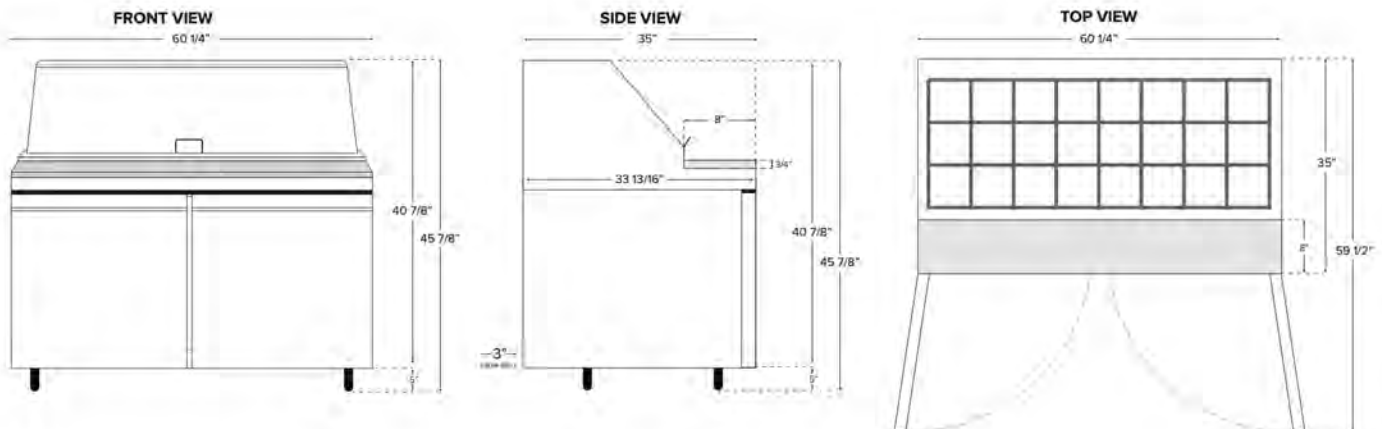

NEMA 5-15P