



RESTAURANT EQUIPMENT HAWAII



CABINET CONSTRUCTION

HEAVY DUTY CONSTRUCTION INCLUDES CORROSION-RESISTANT 304 STAINLESS STEEL INTERIOR AND BLACK COATED STEEL EXTERIOR.

DURABLE 1 1/2" THICK STAINLESS STEEL TOP SURFACE IS EASY TO CLEAN AFTER DISPENSING.

FOAMED-IN-PLACE POLYURETHANE INSULATION ENHANCES THE STRUCTURAL INTEGRITY OF THE CABINET AND HELPS INCREASE ENERGY EFFICIENCY.

2 SOLID, LOCKING DOORS FEATURE STAY-OPEN FEATURE BEYOND 90° FOR EASY KEG LOADING, BUT WILL SELF-CLOSE UNDER 90° TO SAVE ENERGY.

DISPENSING SYSTEM

2 DOUBLE TAP TOWERS WITH 10 1/4" FAUCET HEIGHT MAKES FILLING TALL GLASSES EASY.

INCLUDES 4 "D" COUPLERS PER TAP.

SHELVING

4 SHELVES INCLUDED FOR OPTIONAL USE AS A BACK BAR COOLER.

EACH ACCOMMODATES UP TO 90 LB. TO BEST SUIT YOUR NEEDS.

REFRIGERATION SYSTEM

ENVIRONMENTALLY-SAFE R290 REFRIGERANT. BOTTOM-MOUNTED CONDENSING UNIT POSITIONED FOR EASY MAINTENANCE.

MODEL FEATURES

PREPROGRAMMED DIGITAL CONTROLS WITH AUTO DEFROST

FEATURE. BUILT-IN DRIP TRAY WITH FRONT-FACING DRAIN

CATCHES DRIPS AND SLOSHES TO REDUCE THE AMOUNT OF

CLEAN-UP NECESSARY. DRAIN INCLUDES 1/2" DIAMETER BARB FOR

EASY INSTALLATION.

SPECIAL FEATURES

- HOLDS (3) 1/2 KEGS
- 2 DOUBLE TAP TOWERS WITH 10 1/4" FAUCET HEIGHT
- 1/5 HP COMPRESSOR USES ENVIRONMENTALLY-FRIENDLY R290 REFRIGERANT
- SELF-CLOSING, LOCKING DOORS
- LED LIGHTS ILLUMINATE INTERIOR
- INCLUDES 4 "D" COUPLERS PER TAP
- BLACK COATED STEEL EXTERIOR AND 304 STAINLESS STEEL INTERIOR
- FOAMED-IN-PLACE POLYURETHANE INSULATION
- EASY-TO-USE DIGITAL TEMPERATURE CONTROL
- 115V



PARTS & LABOR



COMPRESSOR

WARRANTY
RESIDENTIAL: REH ASSUMES NO
LIABILITY FOR PARTS OR LABOR COVERAGE
FOR COMPONENT FAILURE, FACTORY DEFECT
OR ANY OTHER DAMAGES FOR UNITS IN-
STALLED IN NON-COMMERCIAL FOODSERVICE
OR RESIDENTIAL APPLICATIONS.



RESTAURANT EQUIPMENT HAWAII

QUALITY COMMERCIAL EQUIPMENT FOR
RESTAURANTS & BARS

VISIT OUR ONLINE STORE FOR PRICING & INFORMATION ON
EQUIPMENT, FOOD TRUCKS & OUR COMMISARY KITCHEN

808-845-5052

TECHNICAL DATA

DIMENSIONS

EXTERIOR DIMENSIONS	69 1/8"W x 27 3/4"D x 36 1/4"H
INTERIOR DIMENSIONS	56 1/2"W x 22 1/2"D x 30 1/2"H
TAP TOWER DIMENSIONS	16"H 3"D DIAMETER
FAUCET HEIGHT	10 1/4"
PRODUCT CAPACITY	(3) 1/2 KEGS
NET VOLUME	23.4 CU. FT.

COOLING

TEMPERATURE RANGE	33°F-40°F
REFRIGERANT	R290
MAX. AMBIENT TEMPERATURE	90°F
DEFROSTING	AUTOMATIC
TEMPERATURE CONTROLLER	DIGITAL
HORSEPOWER	1/5

CONSTRUCTION

NET WEIGHT	298 LB.
GROSS WEIGHT	341 LB.
PACKAGING DIMENSIONS	71 1/2"W x 30 1/2"D x 41 3/4"H
EXTERIOR MATERIAL	BLACK COATED STEEL
INTERIOR MATERIAL	TYPE 304 STAINLESS STEEL
TAPS	4

ELECTRICAL

VOLTAGE	115
AMPS	3.6
Hz	60
PHASE	1
PLUG TYPE	NEMA 5-15P
ELECTRICAL CORD LENGTH	106"

PLAN VIEW

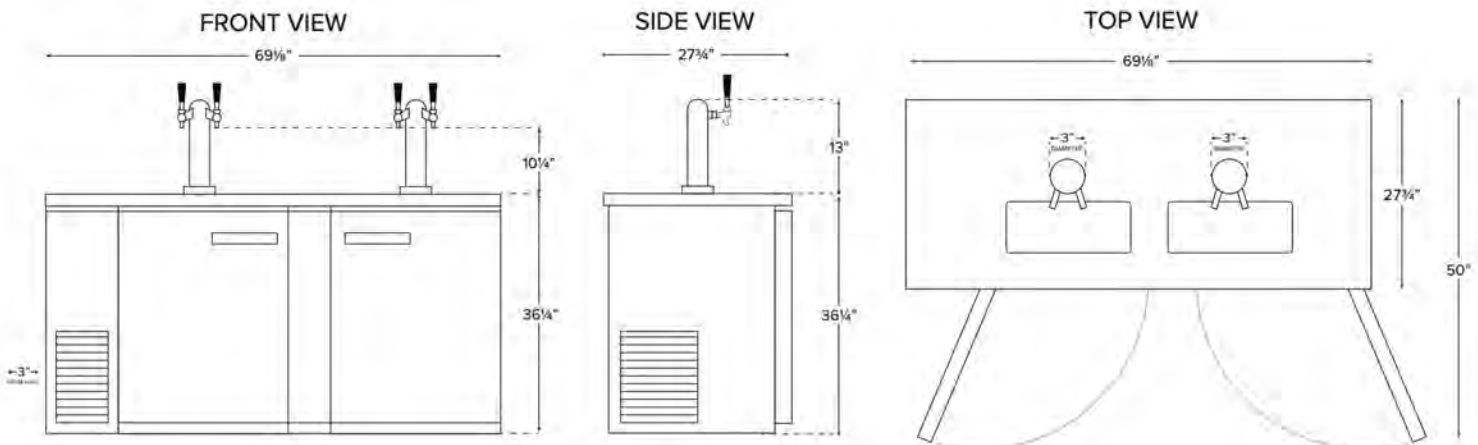

NEMA 5-15P