



RESTAURANT EQUIPMENT HAWAII



CABINET CONSTRUCTION

HEAVY DUTY CONSTRUCTION INCLUDES A 304 TYPE STAINLESS STEEL INTERIOR AND A 430 TYPE STAINLESS STEEL EXTERIOR, RESULTING IN STRENGTH, DURABILITY, AND AN ATTRACTIVE, SLEEK APPEARANCE.

FOAMED-IN-PLACE CFC- AND HCFC-FREE POLYURETHANE INSULATION ENHANCES THE STRUCTURAL STRENGTH OF THE CABINET AND HELPS INCREASE ENERGY EFFICIENCY.

ONE-PIECE REAR GRILL IS EASILY REMOVED FOR CLEANING AND SERVICING.

2 DOORS FEATURE EASY-TO-USE RECESSED HANDLES FOR QUICK INTERIOR ACCESS. DOORS STAY OPEN PAST 90° FOR EASY LOADING, BUT WILL SELF-CLOSE UNDER 90° TO SAVE ENERGY.

REFRIGERATION SYSTEM

ENVIRONMENTALLY SAFE R290 REFRIGERANT.

REAR-MOUNTED CONDENSING UNIT POSITIONED FOR EASY MAINTENANCE.

SHELVING

2 WHITE EPOXY-COATED STEEL SHELVES INCLUDED. EACH ACCOMMODATE UP TO 90 LB.

MODEL FEATURES

COPPER EVAPORATOR COIL ELIMINATES THE POTENTIAL OF CORROSION.

INTERIOR WALL-MOUNTED THERMOMETER FOR EASY TEMPERATURE MONITORING.

PREPROGRAMMED DIGITAL CONTROLLER FEATURES AUTO-DEFROST FUNCTION.

- UNDERCOUNTER FREEZER

INCREASE COLD FOOD PREP STORAGE IN YOUR KITCHEN

SPECIAL FEATURES

- ECO-FRIENDLY R290 HYDROCARBON REFRIGERANT
- STRONG AND SLEEK 430 TYPE STAINLESS STEEL EXTERIOR
- 304 TYPE STAINLESS STEEL INTERIOR MAINTAINS TEMPERATURE FROM (-8)°F - (-1)°F
- TWO EPOXY-COATED STEEL SHELVES ACCOMMODATE UP TO 90 LB. EACH
- FOAMED-IN-PLACE POLYURETHANE INSULATION
- EASY-TO-READ DIGITAL TEMPERATURE CONTROLLER AND AUTO DEFROST FUNCTION.
- 115V; 1/4HP



WARRANTY
RESIDENTIAL: REH ASSUMES NO LIABILITY FOR PARTS OR LABOR COVERAGE FOR COMPONENT FAILURE, FACTORY DEFECT OR ANY OTHER DAMAGES FOR UNITS INSTALLED IN NON-COMMERCIAL FOODSERVICE OR RESIDENTIAL APPLICATIONS.



PARTS & LABOR



COMPRESSOR



RESTAURANT EQUIPMENT HAWAII

QUALITY COMMERCIAL EQUIPMENT FOR
RESTAURANTS & BARS

VISIT OUR ONLINE STORE FOR PRICING & INFORMATION ON
EQUIPMENT, FOOD TRUCKS & OUR COMMISARY KITCHEN

808-845-5052

TECHNICAL DATA

DIMENSIONS

EXTERIOR DIMENSIONS	60 1/4" W x 29 1/2" D x 35 1/4" H
INTERIOR DIMENSIONS	55 5/8" W x 22 7/8" D x 23 1/2" H
NET VOLUME	14.2 CU. FT.
NET WEIGHT	254 LB.
GROSS WEIGHT	323 LB.
PACKAGING DIMENSIONS	83 1/2" W x 34 3/4" D x 85 1/2" H

COOLING

TEMPERATURE RANGE	(-8°F) to (-1°F)
REFRIGERANT	R290
MAX. AMBIENT TEMPERATURE	100°F
DEFROSTING	AUTOMATIC
TEMPERATURE CONTROLLER	DIGITAL
HORSEPOWER	1/4

CONSTRUCTION

EXTERIOR DIMENSIONS	430 STAINLESS STEEL
INTERIOR MATERIAL	304 STAINLESS STEEL
INSULATION MATERIAL	FOAMED-IN-PLACE POLYURETHANE
SHELF SIZE	(2) 26 3/4" x 17"
SHELF MATERIAL	EPOXY-COATED STEEL
SHELF LOAD CAPACITY	90 LB.

ELECTRICAL

VOLTAGE	115
AMPS	3.2
Hz	60
PHASE	1
PLUG TYPE	NEMA 5-15P
ELECTRICAL CORD LENGTH	84"

PLAN VIEW

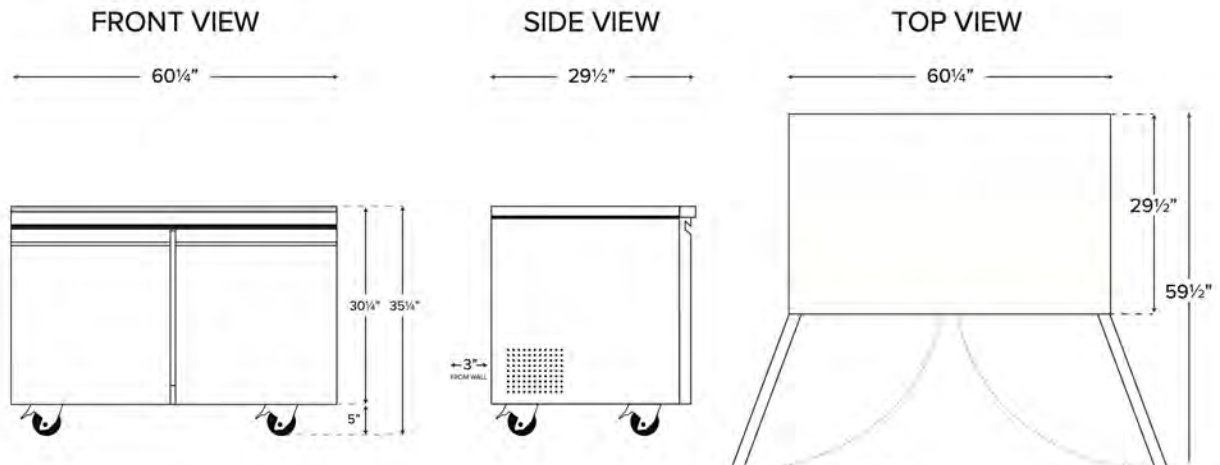

NEMA 5-15P