

## PEAQ – This is what we do...

We can work with you to deliver efficient changes or manage opportunities to optimize your business capabilities. We understand you may be very busy, so we are offering to take the headache away regarding new equipment, products, processes or systems in your factory. If you're a brand owner we can take on any aspect to help your product to market efficiently.

Our service is to ensure you can really rely on us to manage the changes or support you to deliver efficiently your business needs.

See below a guide to some of the services or tasks we can offer you support, our services go well beyond our examples below if you would like further information contact us to see how we can help you and realise your business full potential today.



### QUALITY MANAGEMENT SYSTEMS



- Review of existing systems
- Updating policies and procedures
- Audit schedules and Internal Audit design
- Trending of NCR's and other actions
- Conduct Internal Audits
- Preparation for external Audits
- Compliance Audits
- Audit coaching
- Supplier or internal action review and close out
- Root Cause Analysis and effective close out
- Conducting Supplier Audits
- Hosting customers or external audits
- Integration into QMS of new processes or systems
- Setting appropriate KPI's to drive Quality
- Drive GMP in work place
- Set up sample plans and test program
- Review of Quality data and Trending interpret into spec's and practices



- Review supplier specs and interpret into internal process or product specs
- Trending Raw materials and components data



## PRODUCT MANAGEMENT



- Support product manufacture ensure quality expectations are met
- Scale up trials of concepts
- Retain sample management for shelf life
- Quality defect support to resolve issues
- Complaints management
- Product Batch information management
- Corrective action and Preventative action (CAPA) support
- Customer query assistance and support
- Product Improvement planning and delivery
- Product transfer
- Optimising and or cost management of products
- Problem solving
- Manufacturing Supplier management
- Specification authoring
- Service level agreements
- Manufacturing Capability Audits
- Materials and component quality issue management
- Obsolescence management
- Assistance for export documentation and registrations

## PROJECT MANAGEMENT

- Turn key management of new plant or product development from concept to installation and product sign off
- Scoping and concepts development plan



- Sourcing of equipment or suppliers
- Change management evaluation FMEA
- Feasibility study
- Continuous improvement optimization of processes

## MANUFACTURING SUPPORT



- Validation of new plant and procedures
- Process qualification pre-factory acceptance checks
- Installation risk assessments and planning
- Operation qualification
- Optimisation of plant
- Utilities and infrastructural requirements assessment
- HACCP Flows and plans
- Glass and brittle plastic plans
- SOP for processes/Quality and coaching
- Issue investigation
- Plant Capability study
- Cost and efficiency analysis
- Preventative maintenance plans
- PUWER risk assessment of plant
- Internal Good Manufacturing Practice Audits
- External Supplier Audits
- Customer support to deliver services requested

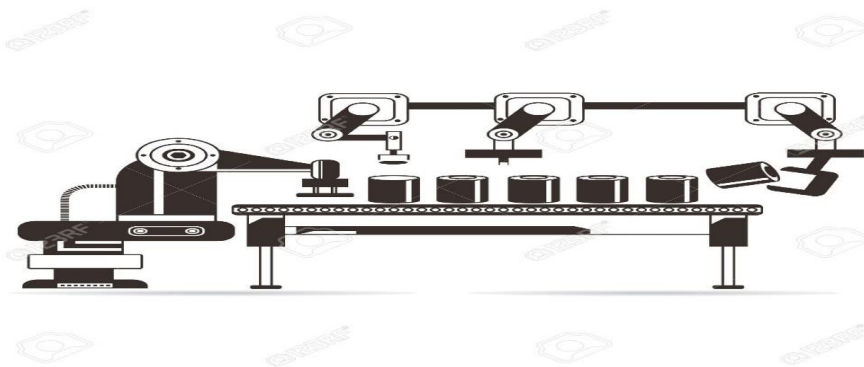

•