

Robotics Engineering

Implementation and development of a room light controller Using ARDUINO AND RFID FOR ANY SCHOOL, College or university

Research Paper no:1

Written by : Maher Ali Rusho And Ayan Ali Rudro

Date: 18.04.2022

Subject :Robotics Engineering

❖ **Resources:-**

- ❖ https://www.academia.edu/Documents/in/Arduino_Uno
 - ❖ https://www.academia.edu/50797308/MODERN_IRRIGATION_SYSTEM
 - ❖ <https://www.egr.msu.edu/classes/ece480/capstone/spring15/group05/uploads/4/7/5/1/47515639/finalreport.pdf>
 - ❖ <https://www.udemy.com/course/arduino-build-arduino-practical-projects/>
 - ❖ <https://youtu.be/4FK0LAivdPs>
 - ❖ <https://youtu.be/r2vjP7EHiaE>
 - ❖ <https://youtu.be/PgRAVSAquRw>
 - For developing the structure of research paper:
 - <https://scholar.google.com/>
 - <https://link.springer.com/>
 - <http://www.jurn.org/#gsc.tab=0>
 - <https://www.refseek.com/>
-

Introduction

In the present-day scenario, where the energy crisis is a major concern ,energy conservation is one big step for solving the problem of

Energy demand. As a part for energy conservation, we have an idea to reduce wastage .

Based on the project title “ Implementation and development of a room light controller Using ARDUINO AND RFID FOR ANY SCHOOL,College or university “

,we can control the amount of lightening in a room by constantly monitoring

The level of luminance in a room . Lights are controlled such that required required illumination is available in the room . It can be applied effectively

In commercial buildings like school ,college ,university .

On a normal day there is a bright sun the lights will be off ,the controller And on a cloudy day the illumination will be low , the controller calculates the required lightening by checking the illumination level and turned on the light. Thus we can successfully optimize the wastage of energy .

We can also maximize the RFID (Radio-frequency Identification) technology

Or Biometrics that will enable the system to work . The lab technician and the principle of Monipur High School are the ones given the authority of the

System . At the top of their ID or via biometrics .It will make the system to work . The system can be monitored in the stock room located at room no: 103 Of Monipur High School Building .

Abstract

The project titled " Implementation and development of a room light controller using Arduino and RFID " aims to save the energy by controlling the lights at Monipur College laboratories by designated authorities namely the teachers and lab technician . This focus how to reduce the energy consumption by minimising the wastage ,turning of the lights when not required automatically by monitoring the light availability in the room . Light intensity is the range 90-100% is optimum for normal light . If intensity is greater than 90% then no lighting is required . Subsequently for every 20% drop in intensity a 10 watts lamp is turned on lightening . In summary This was the whole experience of our team 30 days of perseverance . I would thank to our every team members , professors ,principle and lab technicians . Thanks for your patience . My research paper is accepted by few international journals like –

[*International Journal of Science and Research (IJSR)

***VERTEX RESEARCH AND TECHNOLOGY**

** International Journal of Innovative Science and Research
Technology(IJISRT)]*

Project description =>

- ⇒ *To implement and develop a room light using ARDUINO AND RFID*
- ⇒ *Specific objective => To use a biometric process or RFID for the authorized personnel*

a. **Mythology And Timeline =>**

The project will describe a complete room light control system for a better way of saving energy using ARDUINO and RFID Tech. The overall methology includes a combination of previous project studies , ideas and hardwork

Block diagram of this project =>

Block Diagram of the project:

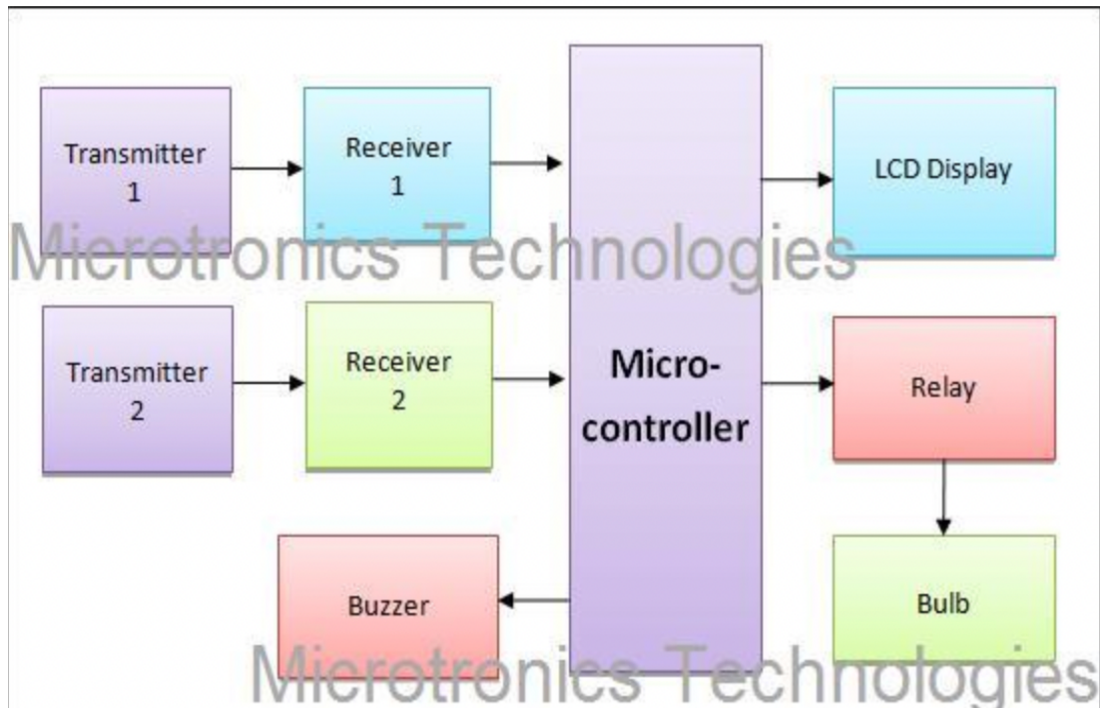

Description in detail:

the following are the important modules in this project:

1. **IR Transmitter.** We have implemented the Person counter module using 2 transmitters and 2 receivers. We have used Infra-Red transmitters. The reason behind choosing IR LED is, infrared beams are not visible to human eyes and they are not easily triggered by other sources in the environment. Transmitters used are IR LEDs.
2. **IR Receiver.** We have used the IR sensor as an Infrared receiver. It is an active-low device, which means it gives low output when it receives the Infrared rays. So when the IR rays are interrupted by any person then Microcontroller will receive a high pulse from the IR receiver.
3. **LCD Display:** We have used 16×2 alphanumeric Liquid Crystal Display (LCD) which means it can display alphabets along with numbers on 2 lines each containing 16 characters. This display should be placed outside the room. It displays various messages like "Person Counter Incremented", "Person Counter Decrement", "No of Person in Room = XYZ" where XYZ is the actual person count.
4. **Relay.** We have used a 12-volt relay. Since Microcontroller can not turn on relay directly, we have used a Relay driver circuit. This circuit consists of a transistor

that is used to turn on relay through Microcontroller. We have used an SPDT relay. SPDT means Single Pole Double Throw relay. In this project, we have provided 2 pin connector as an output of Relay. One of these 2 pins is connected to the Normally open terminal of the Relay which is also known as NO contact.

5. **Darlington pair.** It is used to increase the current gain. The output of 555 IC is given to the Darlington circuit. And the output of the Darlington pair is given to IR led, thus it increases the current through Infrared LEDs which helps in increasing the range of infra-red rays emitted from IR LEDs.
6. **Microcontroller.** This is the CPU (central processing unit) of our project. We have used 89s51 which is a Microcontroller of 8051 microcontroller family. The various functions of Microcontroller are like:
 - **Bidirectional Visitor counter section** – It is bidirectional because we have used 2 sensors on a single door. The microcontroller does the function of Reading the digital input from two infrared receivers and calculates the number of persons from them.
 - **Display** – Microcontroller sends the person count to LCD so that the person operating this project should read the number of persons inside the room.
 - **Automatic Room Light controller section** – Microcontroller turns on the Room Light when the person count is greater than or equal to one. And turn off lights when the count is zero. This is done by Relay. Since the relay is used, you can connect an AC bulb or DC bulb as per your requirement. We will provide a bulb holder to connect the AC bulb.

How to give a demo of this project:

- There are 2 transmitters and 2 receivers placed in front of each other. Swap any object (like mobile) or your fingers (not single finger) in front of those sensors.
- Then Microcontroller increments or decrements the counter.
- Once the count is non-zero, the room light is turned on using a relay.
- Now swap object in reverse direction then the system decrements the count. And room light is turned off once the count becomes zero.

Enhancement added to this project:

We have added a Light Dependent Resistor (LDR) in this project.

Purpose of LDR: Light sensor – LDR will detect the sunlight in the room (or we can say LDR is used to detect daytime)

If there is enough sunlight in the room (which means it is daytime) then the relay will not be turned on even if the person count is greater than zero. In this mode, it will work only as a Person counter to save the electricity and works as an **energy saver**. And if there is insufficient sunlight in the room then only the relay will be turned on so as to turn on the bulb.

Applications of the project:

1. Digital Visitor Counter can be used in various rooms like seminar hall, conference hall where the capacity of the room is limited and should not be exceeded. The project will display an actual number of persons inside the room.
2. **"Automatic Room light Controller with Visitor Counter"** can be used in classrooms, study rooms in colleges.
3. Automatic Room light Controller project can also be used in our home because many times we come out of our bedroom or any other room and we forgot to turn off the room light.
4. The **Bidirectional person counter project** can be used in Cinema halls, multiplex, malls as well as in temples to count the number of a person entering inside. So that these places should not get overcrowded to avoid congestion.

Advantages of the project:

1. The main advantage of this project is that it helps in energy conservation. Because when there is nobody inside the room then lights are automatically turned off.
2. Human efforts to count the number of persons are eliminated. Since this project does the automatic person counting with the help of two sensors installed on the
3. The implementation of this system is subdivided into two categories which are hardware design to , to design the dimmer circuit and RFID devices that detect the unique id in principle card . The hardware devises used in Arduino as platform , for the system design which will display the monitoring of light .
4. Statistical timeline: of our research

Timeline

	Week 1	Week 2	Week 3	Week 4	Week 5	Week 6	Week 7
Thesis Writing							
Introduction Literature Review	■	■	■				
Methodology			■	■	■	■	
Research Process			■	■	■	■	
Conceptual Framework				■	■	■	■

Final Expected output

Prototype of smart E-room :visitor based automated light control

Copyright Agreement for IJSRT,IJAEM, Vertex Research And Technology

Implementation and development of a room light controller Using ARDUINO AND RFID FOR ANY SCHOOL, College or university

Author(s):

Maher Ali Rusho

Ayan Ali Rudro

The undersigned hereby transfer any and all rights in and to the paper including without limitation all copyrights to the IJSRT , IJAEM ,Vertex Research and Technology . The undersigned hereby represents and warrants that the paper is original and that he/she is the author of the paper, except for material that is clearly identified as to its original source, with permission notices from the copyright owners where required. The undersigned represents that he/she has the power and authority to make and execute this assignment.

This agreement is to be signed by at least one of the authors who have obtained the assent of the co-author(s) where applicable.

Maher Ali Rusho

(17.03.2022)

(Signature & Date (Author:1))

Rudro 17.03.2022

(Signature & Date (Author:2))

Maher Ali Rusho

(Typed or Printed Name) of [Author:1]

[#Massachusetts Institute Of Technology Manufacturing Engineering Micromaster

Program student [Batch-(2022-2023)]

#Ceo of international youth physics challenge

(rusho.org)]_____

(Institution or Company) of [Author:1]]

Ayan Ali Rudro

(Typed or Printed Name) of [Author :2]

[Monipur High School And College

Co -founder Of Quantum learning

Quantum learning_

(institution or Company) Of Author 2

