

InKorr

This product is represented in Australia, New Zealand, and PNG by:

InKorr Pty Ltd

Address: Unit 8, 1470 Ferntree Gully Road,
Knoxfield VIC 3180, Australia
Email: inkorr.service@inkorr.com.au
General: +61 (0) 413 996 890 (Makarios Wong)
Service: +61 (0) 478 800 003 (Shane Halliwell)

Contact InKorr Pty Ltd for:



Heat Exchangers

- Shell & Tube Heat Exchangers
- Gasketed Plate Heat Exchangers
- Brazed Plate Heat Exchangers
- Crossflow Welded Plate Heat Exchangers
- Plate & Shell Heat Exchangers
- Non Metallic Heat Exchangers
- Corrugated Tube Heat Exchangers
- Spiral Heat Exchangers
- Air-Cooled Heat Exchangers



Vessels, Columns, and Equipment manufactured from:

- Exotic Alloys (Ta, Zr, Ti)
- Graphite and Silicon Carbide
- PTFE Lining



Plastic Lined Valves and Piping

- PTFE
- PVDF
- PP
- and many more!

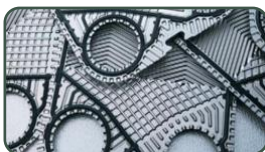

Servicing and reburishment of heat exchangers!

- Plate cleaning
- NDE for crack testing
- Spare parts, both OEM and aftermarket

Plate Heat Exchangers Type XPS

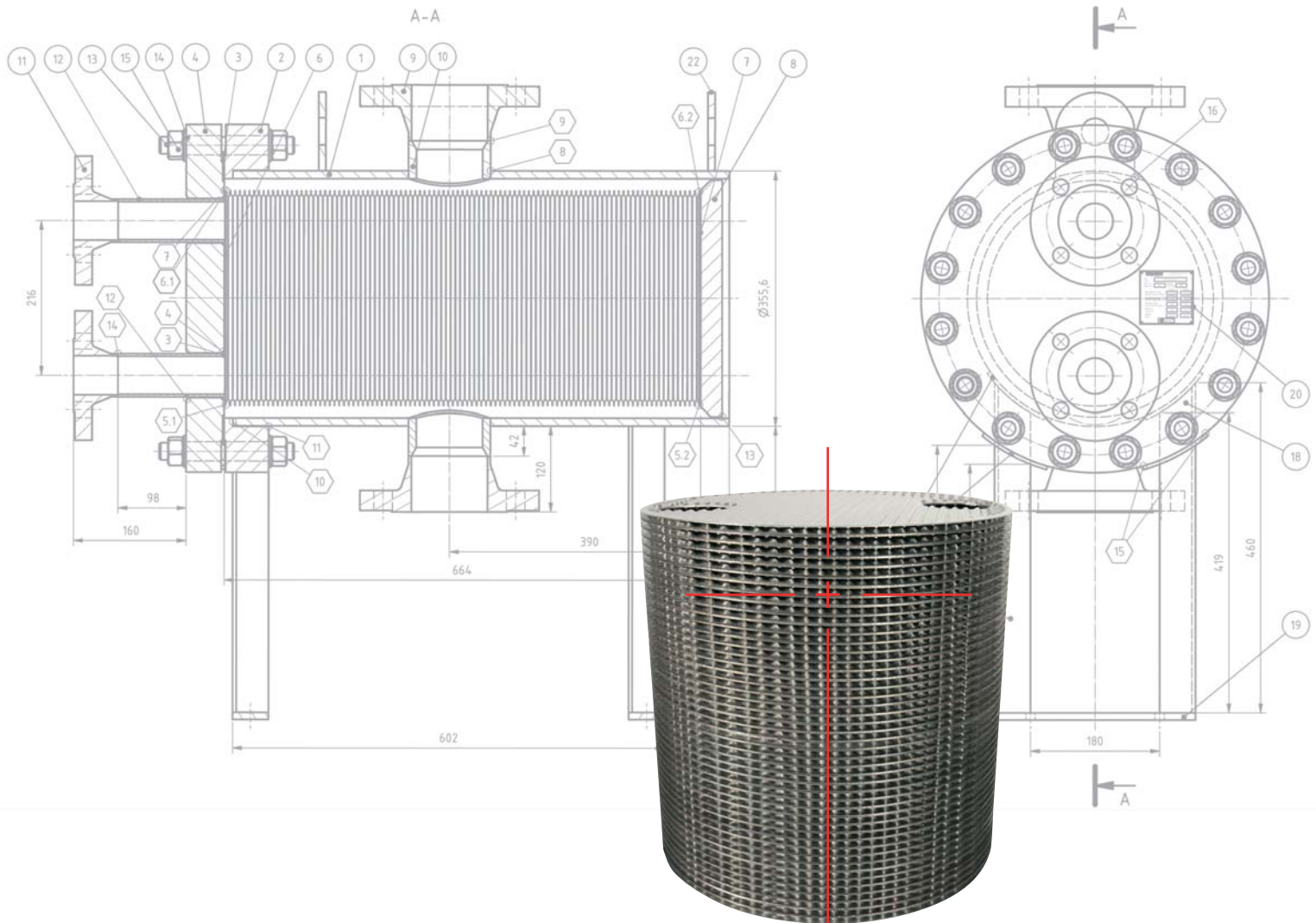

- + safe
- + smart
- + efficient

[**LASER WELDED**]

The XPS for use under hard processing conditions.

- + Our answer to the questions and challenges from the market for heat exchangers is the XPS: the complete heat exchanger for industrial applications which combines all the benefits of an effective, safe and compact product with innovative manufacture for our customers.

Compact design

In plate heat exchangers the concentration of exchanger surfaces is high but the structural volume for the same performance is many times lower than in shell & tube heat exchangers.

In the round heat exchanger plates of the XPS the stresses caused by pressure or temperature are more uniformly distributed than in rectangular plates and thus the risk of stress cracks is minimised.

The cylindrical jacket is the optimal shape for a pressure vessel, allowing lower material thicknesses and a lower weight than for apparatus of square construction.

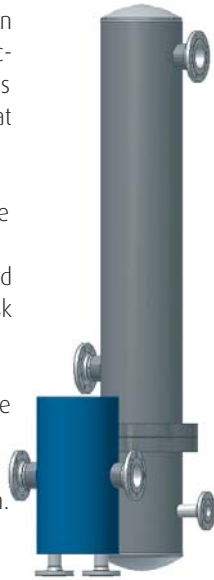

COMPARISON: XPS vs. Shell & Tube Heat Exchanger

Laser welded plate packs

Due to the use of laser welding technology the weld seams on the XPS achieve much greater connection cross-sections. At the same time the heat brought in by welding is minimised.

Minimal heat affected zones mean less annealing colours and fewer changes in the material structure. Smaller weld pool volumes prevent the formation of blow holes or pores during solidification.

The result is plate packs with a greater leakage security and few possible corrosion starting points.

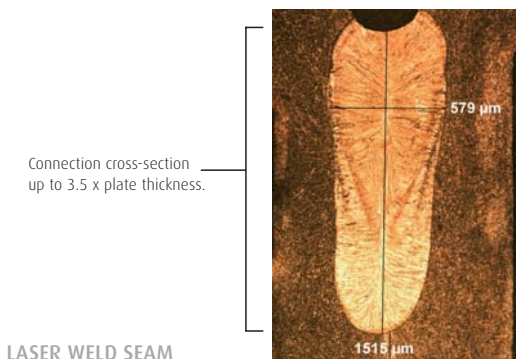

Different corrugation patterns

Our heat exchanger plates are made with a regularly corrugated surface and with different corrugation angles.

Plates with a flat corrugation angle (H plates) allow high heat transfer rates caused by a highly turbulent flow in the flow channels. Plates with a steep corrugation angle (L plates) are used in applications which have to be optimised for pressure loss.

In gas/gas applications or in slightly contaminated media we use plates with a greater channel cross-section (G plates).

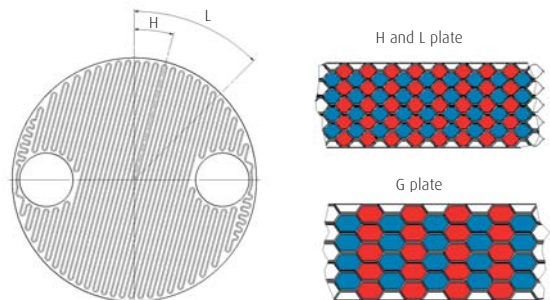
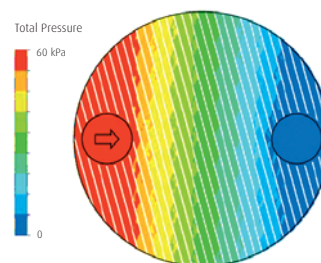

PLATE PROFILE

Optimal operating characteristics

Along with high heat transfer rates, the turbulent flow also leads to a strong self-cleaning effect and permits a high temperature approach of the media.

The pressure distribution at right angles to the flow is very homogeneous, so the media distribute themselves very well in the lateral direction, and thus across the whole plate.



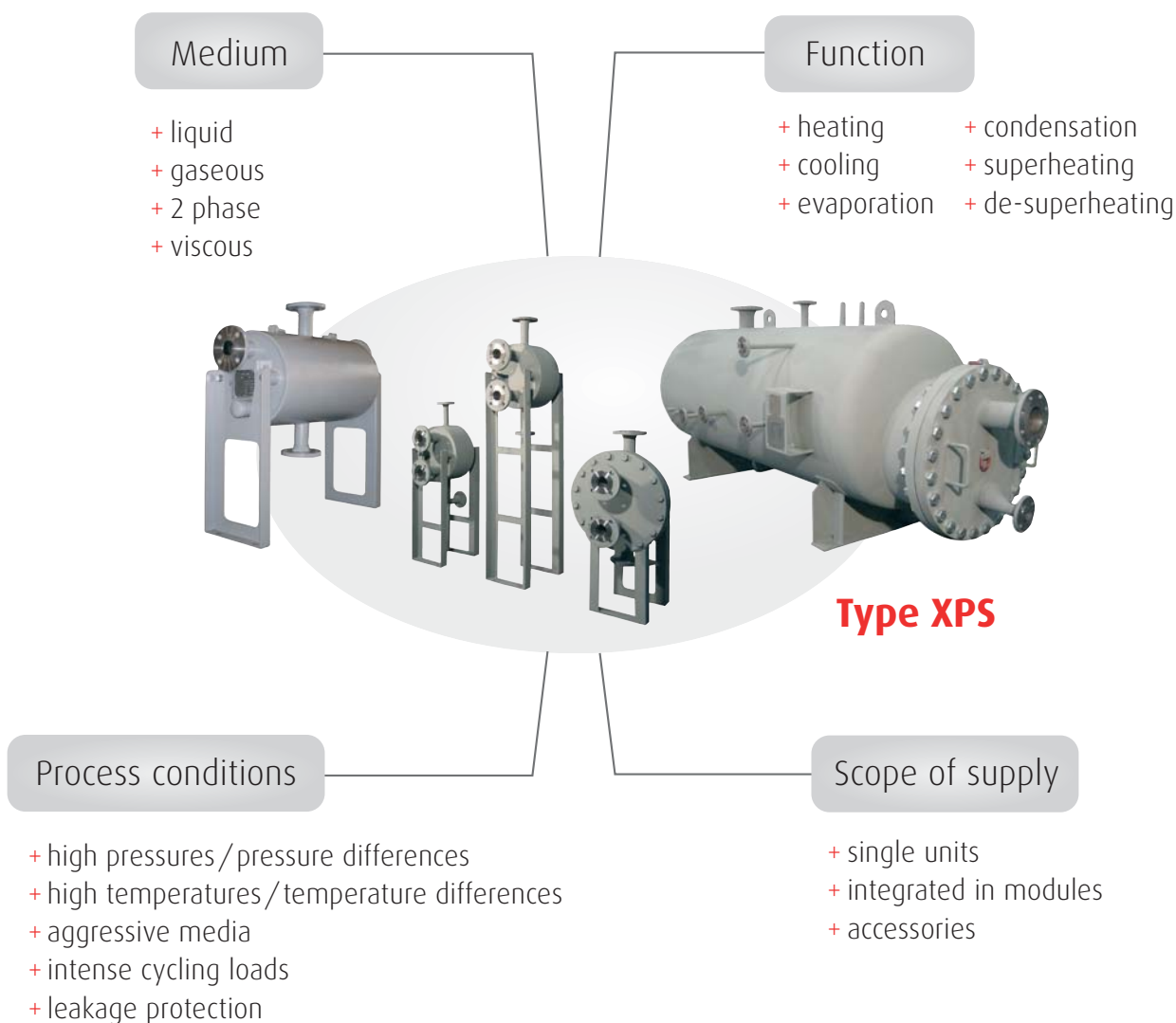

For applications in

- + Chemicals
- + Petrochemicals
- + Oil and gas delivery
- + Pharmaceutical industry
- + Energy generation
- + Bio-energy
- + Shipbuilding
- + Paper and steel manufacture



Components

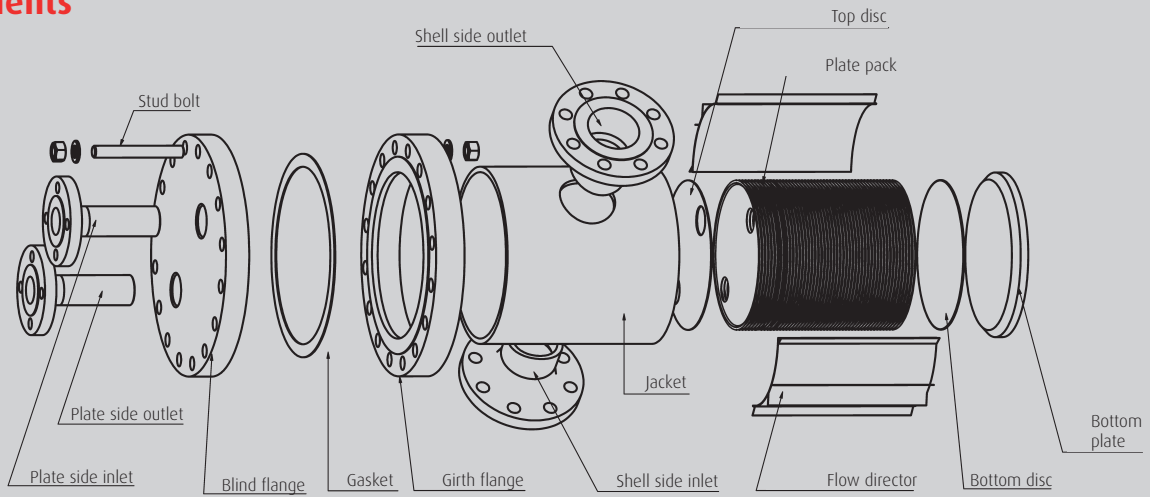

Container shapes

Fully welded



A completely gasket-free design

Accessible from one end



Allows shell side inspection of the plate pack

Accessible from both ends



Two packs – for very high performance or for different circuits

Function

Heat exchanger plates form parallel channels through which hot and cold media flow alternately.

The heat transfer takes place through the walls of the plate channels, from the hot to the cold medium.

Primary and secondary media are optionally fed through the plate or the shell side

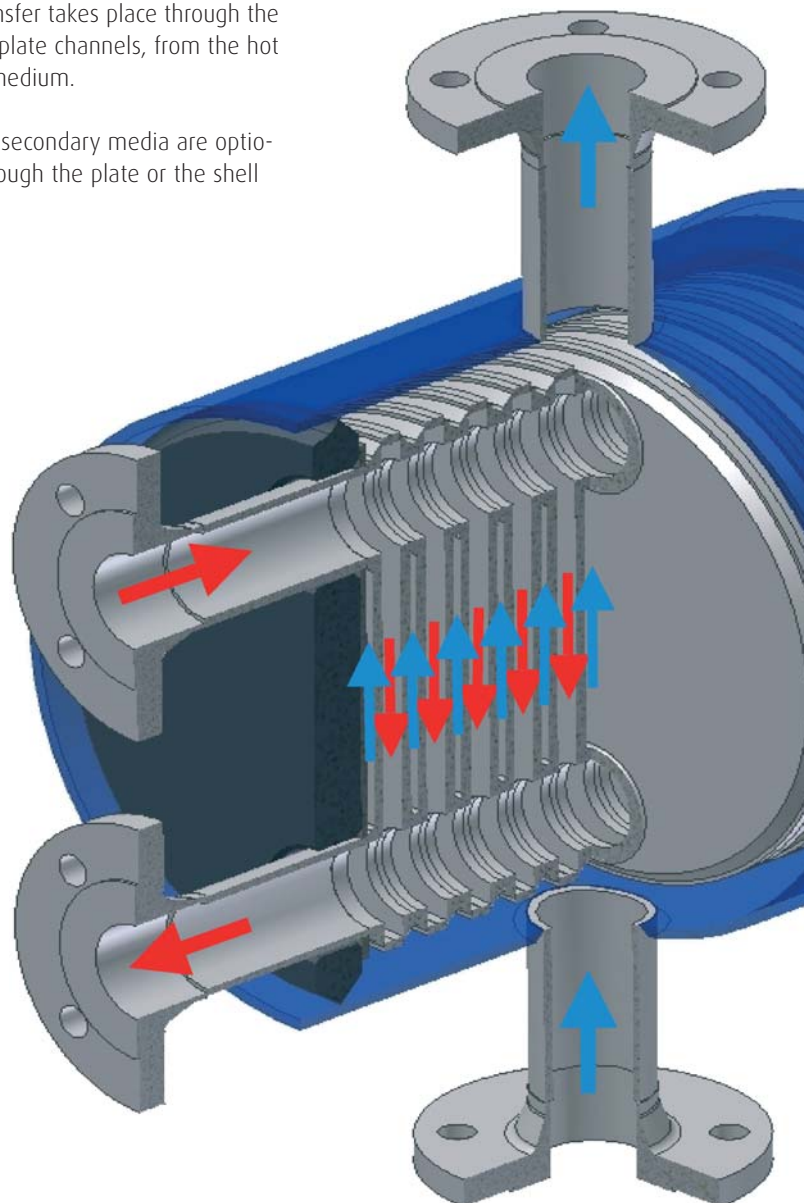

Check this!

Installation positions and set-ups

Horizontal or vertical, according to the guidelines of the process technology or to optimise the connection geometry

On feet



possible with feet on the end plates

On saddles



for units which open at both ends or longer models

On lugs



frequently for vertical installations e.g. on columns

Plate circuits

Inlet and outlet on both end faces

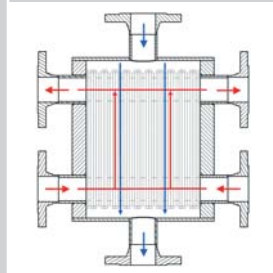

For large volumetric flows at the plate side

Plate side deflection

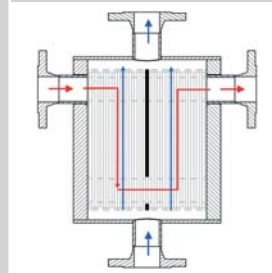

For greatly differing volumetric flows plate and shell side

Shell and plate side deflection

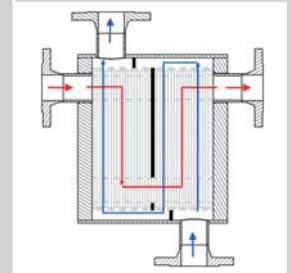

For optimising the pressure loss and transfer rates on both sides

Flow directions

Counter flow

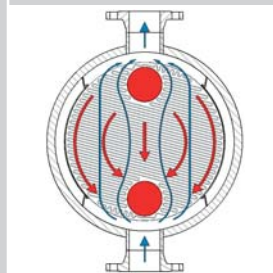

the most common form of flow guidance

Cross flow

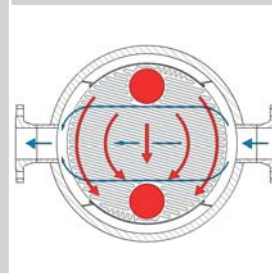

for different flow resistance on the primary and secondary side, e. g. gas / liquid applications

Parallel flow

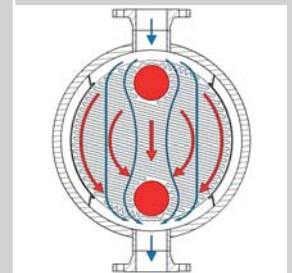

for maximum temperature differences at the inlet

Development and manufacture

Modern manufacturing plant

At the heart of the manufacture of XPS heat exchangers is our laser welding centre. Together with the world market leader in laser welding technology, GESMEX has developed a process giving high quality weld seams and repeatable accuracy.

Our production plant also includes TIG and MAG welding work stations, pressing, assembly and test rigs and also storage and logistics facilities for a medium-sized industrial company.



Dimensioning to suit the application

XPS heat exchangers are individually calculated for each application. The basis for this is our design programme (GSX-Calc) which is based on a cell model theory and whose results are continuously validated in test series. The programme is regularly optimised particularly for complex applications such as condensation, partial condensation or vapourisation.

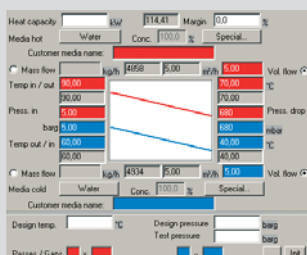

Professional order processing

From the tender preparation right up to delivery our team of qualified engineers and skilled workers is available with specialisations such as thermodynamics engineers, experts in pressure vessels, CAD designers or specialist welding engineers.

Our medium-sized organisation structure allows manufacturing to the individual standards and factory standards of our customers and also a fast reaction to alterations at short notice.



Innovative product development

A very high proportion of the investments made by GESMEX go into product development. We carry out development projects in close co-operation with universities and experienced engineering consultants. The results are confirmed by worst case testing such as burst test, alternating stress or cryogenic tests. In addition to this we implement unique equipment concepts such as for instance replacing the pipe bundles with plate packs in existing shell & tube heat exchangers.



Certified manufacturing

GESMEX is a manufacturer of pressure vessels certified by TÜV Nord in accordance with the PED 97/23/EC, applying AD 2000, HPO Bulletin and also DIN EN ISO 3834 - 2. This includes welding process tests including the certification of our plant operators, TIG and MAG welders and also an audit of documentation and manufacturing plants.

Audits by highly reputed customers in the chemical industry successfully confirm the expertise of GESMEX as a manufacturer of heat exchangers for the process industry.



XPS-Facts

Materials

The selection of materials is determined by the operating media. Several materials are available for standard applications. The product range is constantly expanded when new materials are requested by new applications.

Plate Materials	Shell Materials
Austenitic steels, e. g.: + 1.4404 / AISI 316L + 1.4547 / SMO 254	Ferritic steels, e.g.: + 1.0305 / St. 35.8 + 1.0425 / P265 GH / AISI 516 Gr65
Nickel materials, e. g.: + 2.4068 / AISI N02201	Fine-grain steels, e.g.: + 1.0566 / P355 NL1
Nickel alloys, e. g.: + 2.4602 / Alloy C-22 + 2.4819 / Alloy C-276	Austenitic steels, e. g.: + 1.4301 / AISI 304 + 1.4404 / AISI 316L
Titan materials, e. g.: + 3.7025 / AISI B265 Gr1	Nickel alloys, e. g.: + 2.4602 / Alloy C-22

Flow directors are made from plate materials as well. No elastomers are used in XPS heat exchangers. Fully welded units are absolutely gasket-free. The standard configuration of openable heat exchangers is with graphite tanged steel flat-ring gaskets.

Dimensions

	XPS 50	XPS 100	XPS 150	XPS 200	XPS 300
S1, S2	3/4" - 4"	1" - 10"	2" - 14"	2" - 28"	2" - 24"
P1, P2	2"	4"	6"	8"	12"
Ø [mm]	360	610	890	1.100	1.400
L [mm]	from 150 (depending on number of plates and design pressure) to 2.400				
Area [m ²]	1.5 to 30	max 100	max 320	max 500	max 700

Plate material with a thickness from 0.6 to 1.25 mm is used. All sizes can be delivered with H-, L- or G-plates. Liquid hold-up varies from 3 to 1,000 litres per pressure chamber.

Operating Parameters

The maximum parameters depend on the size of the unit, the materials used and the thickness of the material.

- Operating Pressure: -1 to 150 bar(g)
- Operating Temperature: -200 to 500°C
- Dynamic Viscosity: up to 8.000 mPa s

Approvals

According to PED, XPS heat exchangers are classified as pressure vessels in categories I - IV. The conformity assessment is according to module G. Before delivery, an individual design and pressure test is carried out for each unit. Some designs are delivered with a type-examination certificate.

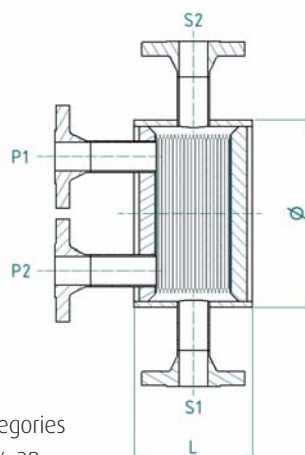

33

passes (plate side and shell side)

H

number of plates plate profile

120

100

size

XPS

type

- + GESMEX designs and manufactures compact heat exchangers for industrial applications. We continuously invest in product development and state-of-the-art manufacturing technology for highly effective heat exchangers and long-run safe operations of our customers.

GESMEX GmbH

Werkstr. 226
19061 Schwerin
Germany



Phone +49 385- 61 73 86-0
Fax +49 385- 61 73 86-29



E-mail: info@gesmex.com
web: www.gesmex.com

GESMEX
German Smart Heat Exchangers