

InKorr

This product is represented in Australia, New Zealand, and PNG by:

InKorr Pty Ltd

Address: Unit 8, 1470 Ferntree Gully Road,
Knoxfield VIC 3180, Australia
Email: inkorr.service@inkorr.com.au
General: +61 (0) 413 996 890 (Makarios Wong)
Service: +61 (0) 478 800 003 (Shane Halliwell)

Contact InKorr Pty Ltd for:



Heat Exchangers

- Shell & Tube Heat Exchangers
- Gasketed Plate Heat Exchangers
- Brazed Plate Heat Exchangers
- Crossflow Welded Plate Heat Exchangers
- Plate & Shell Heat Exchangers
- Non Metallic Heat Exchangers
- Corrugated Tube Heat Exchangers
- Spiral Heat Exchangers
- Air-Cooled Heat Exchangers



Vessels, Columns, and Equipment manufactured from:

- Exotic Alloys (Ta, Zr, Ti)
- Graphite and Silicon Carbide
- PTFE Lining



Plastic Lined Valves and Piping

- PTFE
- PVDF
- PP
- and many more!

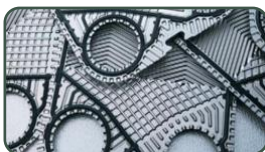

Servicing and reburishment of heat exchangers!

- Plate cleaning
- NDE for crack testing
- Spare parts, both OEM and aftermarket

PFA LINED DIAPHRAGM VALVE

High Performance and Creative Technology company
www.fluonics.com



Head Office & Factory

#561-11, Gwang Gyeok, Ho-Jeo, Wonju-Si, Kangwon-Do, Korea

Tel : 82-33-731-3550 / Fax : 82-33-731-3559

www.fluonics.com



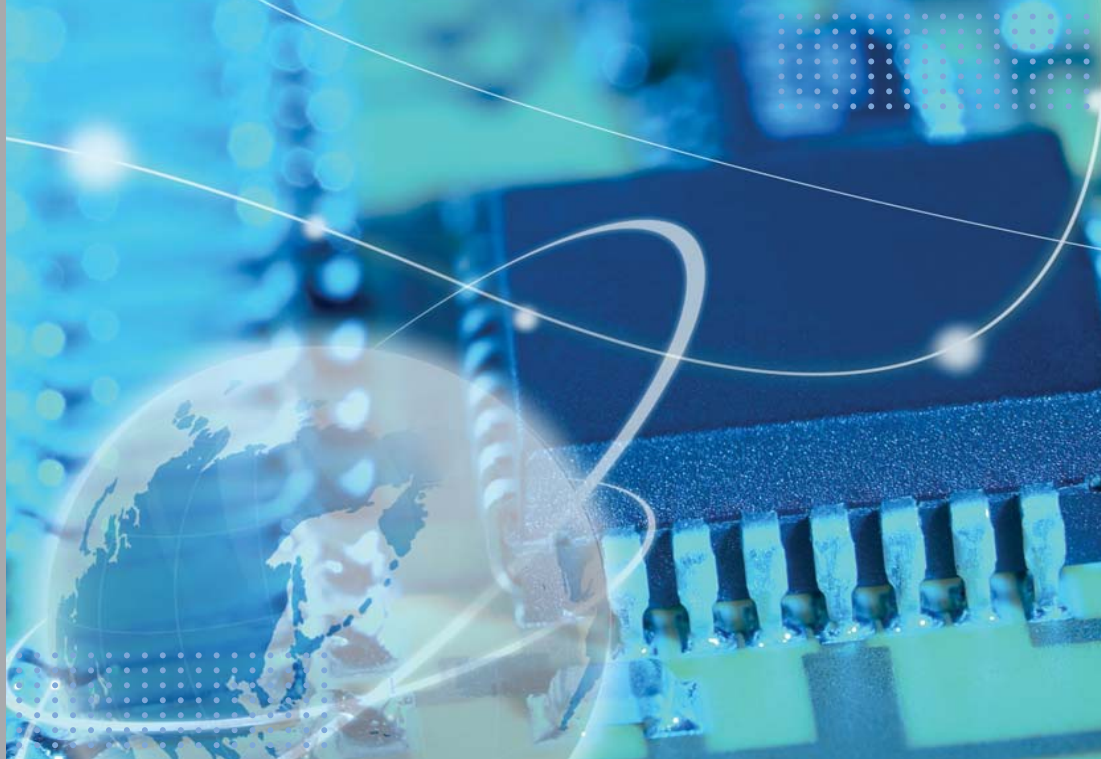

Contents

- 3 Lining Materials
- 4 Features
- 5 Materials
- 6 Diaphragm valve
- 7 Automated Diaphragm valve

Lining Materials

PFA

PFA exhibits thermal characteristics like to PTFE, being able to withstand super low to high temperatures (260°C Maximum temp. for continuous use). It is also transparent and mechanically strong under high temperature. It is easily workable besides applicable with extrusion molding to the same degree as general thermoset plastics. It is used where purity is important, such as semiconductor wafer baskets, piping couplings and non-corrosive linings. PFA has better mechanical strength at high temperatures than FEP, and excellent moldability for easy processing by extrusion, compression, blow, transfer and injection molding methods. Due to the high bonding strength of the carbon, fluorine and oxygen atoms, PFA demonstrates nearly the same outstanding capabilities as PTFE in temperatures ranging from -200°C to +260°C.

FEP

FEP is a copolymer of tetrafluoroethylene and hexafluoropropylene. FEP consists of carbon atoms and fluorine atoms, as does PTFE, and has a molecular structure in which one of the fluorine atoms bonded to the carbon atoms. FEP has a lower melt viscosity than PTFE and can be processed like other molten thermoplastic resins by extrusion, transfer, injection, and compression molding. Because the bonding energy between its carbon and fluorine atoms is so high, and because the carbon chain is completely surrounded by fluorine atoms, FEP fluorocarbon polymer retains excellent thermal, electrical, and chemical stability. Therefore, it shows high performance in electrical, chemical, and medical applications in temperatures ranging from extremely low to extremely high (-200°C ~ +200°C / -328°F ~ +392°F).

PTFE

The fluorine atoms completely cover the carbon chain backbone and protect the carbon-carbon bond from attack. The fluorine atoms are also responsible for the low surface energy and exceptional frictional characteristics of PTFE. Because of very high melt viscosity, PTFE does not flow above its melting point. It requires special polymer processing like paste extrusion, compression molding and sintering. Among all the fluoroplastics products, PTFE offers the highest heat resistances at 260°C (maximum temp. for continuous use). It is not corroded by most chemicals and has good electrical insulation and dielectric characteristics. Moreover, it has a unique non-stick property and the lowest coefficient of friction amongst solids. It is the most widely used fluoroplastics, now found in O-rings, gaskets, bearings, tube, wiring, hot plates and irons because of its non-stick property, as well as chemical tank linings.

Property	PFA			FEP			PTFE		
	Testing Method	Value	Unit	Testing Method	Value	Unit	Testing Method	Value	Unit
Specific Gravity	ASTM D-3307	2,14-2,16	—	ASTM D-2116	2,12-2,17	—	ASTM D-3307	2,14-2,20	—
Melt Flow Rate	ASTM D-3307	1-3	g/10 min	ASTM D-2116	6	g/10 min	—	—	—
Melting Point	ASTM D-3307	304	°C	ASTM D-2116	260	°C	ASTM D-3307	327	°C
Tensile Strength	ASTM D-3307	33,3 (4835)	MPa (psi)	ASTM D-2116	31	MPa (psi)	ASTM D-3307	13,7-34,3 (1990-4980)	MPa (psi)
Elongation	ASTM D-3307	420	%	ASTM D-2116	370	%	ASTM D-3307	200-400	%
Chemical resistance	—	Excellent		ASTM D-2116	Excellent		—	Excellent	—

Features

High integrity handwheel with ergonomic design assures comfortable, precise control.

Highly visible from a distance with clear indication of valve position.

The smooth contoured body has minimal pockets, cavities or dead spaces which prevent accumulation or stagnation of process fluids or contaminants.

Remove the pollutants by electro polishing of the external surface treatment as standard. (Paint coating available if on request)

Improvement in the intensity of illumination and the transparency of PFA lining.

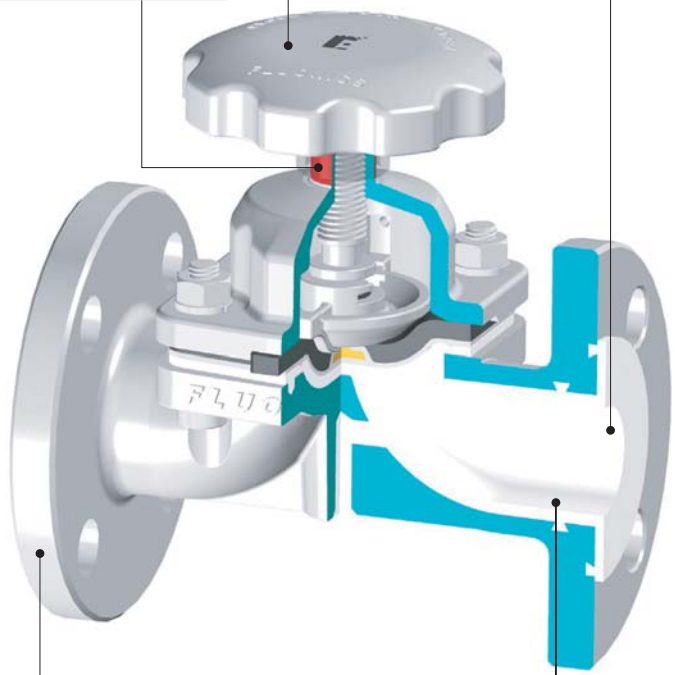

Materials

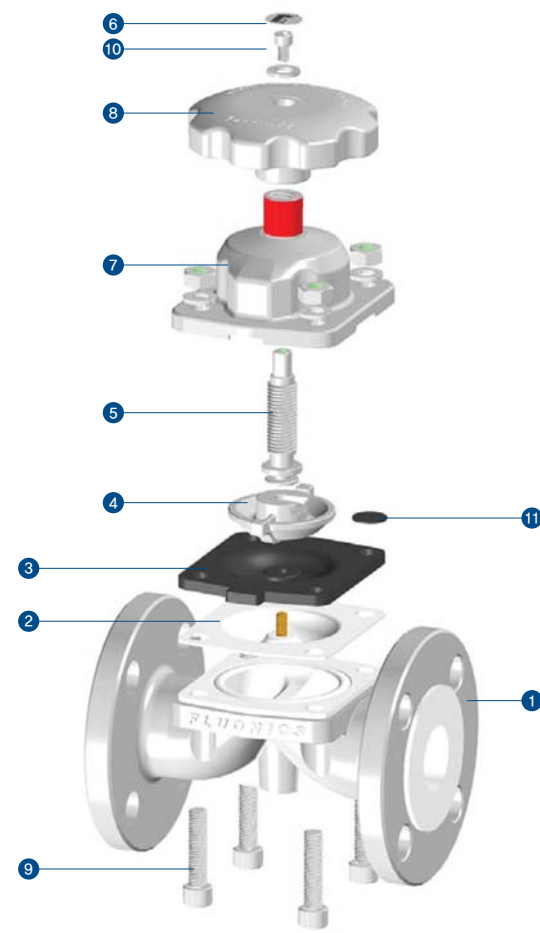

Item No.	DESCRIPTION	MATERIAL		
		STAINLESS STEEL	CARBON STEEL	DUCTILE IRON
1	BODY	ASTM A351 CF8 / CF8M, PFA, FEP Lined	ASTM A216 WCB, PFA, FEP Lined	ASTM A395 PFA, FEP Lined
2	DIAPHRAGM	M-PTFE	M-PTFE	M-PTFE
3	CUSHION RUBBER	EPDM / VITON	EPDM / VITON	EPDM / VITON
4	COMPRESSOR	ASTM A351 CF8 / CF8M	ASTM A351 CF8 / CF8M	ASTM A351 CF8 / CF8M
5	SPINDLE	ASTM A479 - 304	ASTM A479 - 304	ASTM A479 - 304
6	NAME PLATE	ASTM A240 - 304	ASTM A240 - 304	ASTM A240 - 304
7	BONNET	ASTM A351 CF8 / CF8M	ASTM A216 WCB	ASTM A351 CF8 / CF8M
8	HAND WHEEL	ASTM A351 CF8 / CF8M	ASTM A216 WCB	ASTM A351 CF8 / CF8M
9	STUD BOLT	SUS304	SUS304	SUS304
10	WRENCH BOLT	SUS304	SUS304	SUS304
11	SPINDLE PLATE	ACETAL	ACETAL	ACETAL

DIAPHRAGM VALVE

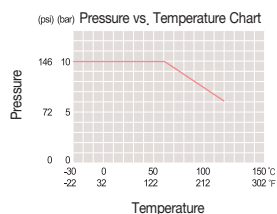
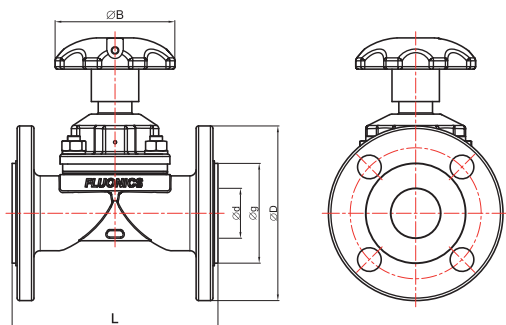

Available Size : 1/2"-6" (15A-150A)

Flange rating : ANSI 150lbs JIS 10K

Nominal size	L		Ø D		Ø g			Ø d		Ø B		Max service Pressure (kgf/cm ²)	Ref.
	A	B	ANSI 150	JIS 10K	JIS 10K		A	B	A	B			
					A	B							
1/2 (15A)	133	107	89	95	40	54	48	20	15	75	63	8	A
3/4 (20A)	133	123	98,5	100	50	54	50	20	20	75	63	8	B
1 (25A)	143	132	108	125	60	59	62	25	25	90	80	8	C
1 1/2 (40A)	180	165	127	140	81	71	78	38	40	105	100	7	D
2 (50A)	210	197	152	155	94	94	94	50	50	115	125	7	E
2 1/2 (65A)	310	222	178	175	125	125	116	76	65	210	125	7	F
3 (80A)	310	260	191	185	125	125	125	76	80	210	160	6	G
4 (100A)	350	313	229	210	157	151	145	100	100	210	230	6	H
6 (150A)	480	412	279	280	216	212	212	150	150	350	300	6	J

Ordering information

Connections	Ref.	Valve type	Ref.	Operating	Ref.
JIS 10K	J	Diaphragm valve	D	Manual	M
ANSI 150lbs	A	Ball valve	B	Actuator	A

Valve body materials	Ref.	Surface finish	Ref.
PFA lined Carbon Steel(WCB/SCPH2)	W	Electropolished	EP
PFA lined Stainless Steel(CF8/SCS13A)	S	Epoxy coated	P
PFA lined Stainless Steel(CF8M/SCS14A)	M	Electropolished + Buffed	EB
PFA lined Ductile Iron(A395 D,I/FCD)	F		

Control function	Ref.	Diaphragm material	Ref.
Normally open	NO	M-PTFE / EPDM	PE
Normally closed	NC	M-PTFE / VITON	PV

Order example	J	D	M	B	S	EP	-	PE
Connection	J							
Valve type		D						
Operating			M					
Nominal size				B				
Valve body material					S			
Surface finish						EP		
Control function							-	
Diaphragm material								PE

AUTOMATED DIAPHRAGM VALVE

Depending on diameter and materials of construction, up to 10 bar working pressure and 150°C working temperature. Chemical resistance of actuator.

- Actuator : Membrane actuator, plastic
- Nominal sizes : DN 15 - DN 100 (Actuator size 25-100)
- Control function : Normally closed (NC), control function 1
Normally open (NO), control function 2
Double acting (DA), control function 3
- Ambient temperature : Max, 60°C
- Control medium : Inert gases, Max, 40°C
- Accessories : Stroke limiter / Electrical position indicator / Manual override



DIMENSIONS (CONTROL FUNCTION 1)

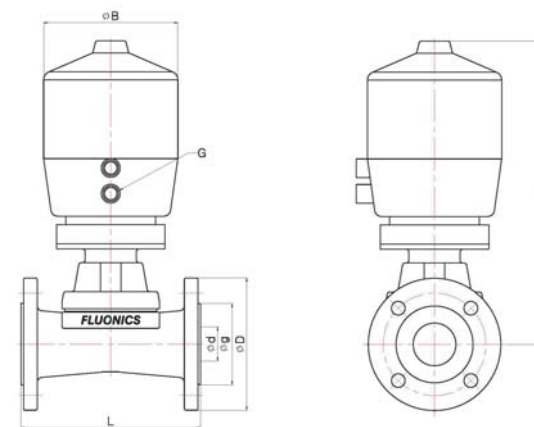

Nominal size	L		Ø D		Ø g			Ø d		Ø B		H	G
	A	B	ANSI 150	JIS 10K	ANSI 150	JIS 10K		A	B	A	B		
						A	B						
1/2 (15A)	133	107	89	95	40	54	48	20	15	100	222	1/4"	
3/4 (20A)	133	123	98,5	100	50	54	50	20	20	100	222	1/4"	
1 (25A)	143	132	108	125	60	59	62	25	25	100	224	1/4"	
1 1/2 (40A)	180	165	127	140	81	71	78	38	40	126	296	1/4"	
2 (50A)	210	197	152	155	94	94	94	50	50	157	355	1/4"	
2 1/2 (65A)	310	222	178	175	125	125	116	76	65	157	371	1/4"	
3 (80A)	310	260	191	185	125	125	125	76	80	261	371	1/4"	
4 (100A)	350	313	229	210	157	151	145	100	100	261	400	1/4"	