

# InKorr

This product is represented in Australia, New Zealand, and PNG by:

## InKorr Pty Ltd

**Address:** Unit 8, 1470 Ferntree Gully Road,  
Knoxfield VIC 3180, Australia  
**Email:** [inkorr.service@inkorr.com.au](mailto:inkorr.service@inkorr.com.au)  
**General:** +61 (0) 413 996 890 (Makarios Wong)  
**Service:** +61 (0) 478 800 003 (Shane Halliwell)

### Contact InKorr Pty Ltd for:



#### Heat Exchangers

- Shell & Tube Heat Exchangers
- Gasketed Plate Heat Exchangers
- Brazed Plate Heat Exchangers
- Crossflow Welded Plate Heat Exchangers
- Plate & Shell Heat Exchangers
- Non Metallic Heat Exchangers
- Corrugated Tube Heat Exchangers
- Spiral Heat Exchangers
- Air-Cooled Heat Exchangers



#### Vessels, Columns, and Equipment manufactured from:

- Exotic Alloys (Ta, Zr, Ti)
- Graphite and Silicon Carbide
- PTFE Lining



#### Plastic Lined Valves and Piping

- PTFE
- PVDF
- PP
- and many more!

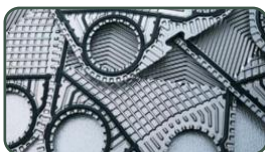

#### Servicing and reburishment of heat exchangers!

- Plate cleaning
- NDE for crack testing
- Spare parts, both OEM and aftermarket

# LINED PIPE & FITTINGS

High Performance and Technology Creative company  
[www.fluonics.com](http://www.fluonics.com)



## Head Office & Factory

#561-11, Gwang Gyeok, Ho-Jeo, Wonju-Si, Kangwon-Do, Korea

Tel : 82-33-731-3550 / Fax : 82-33-731-3559

[www.fluonics.com](http://www.fluonics.com)



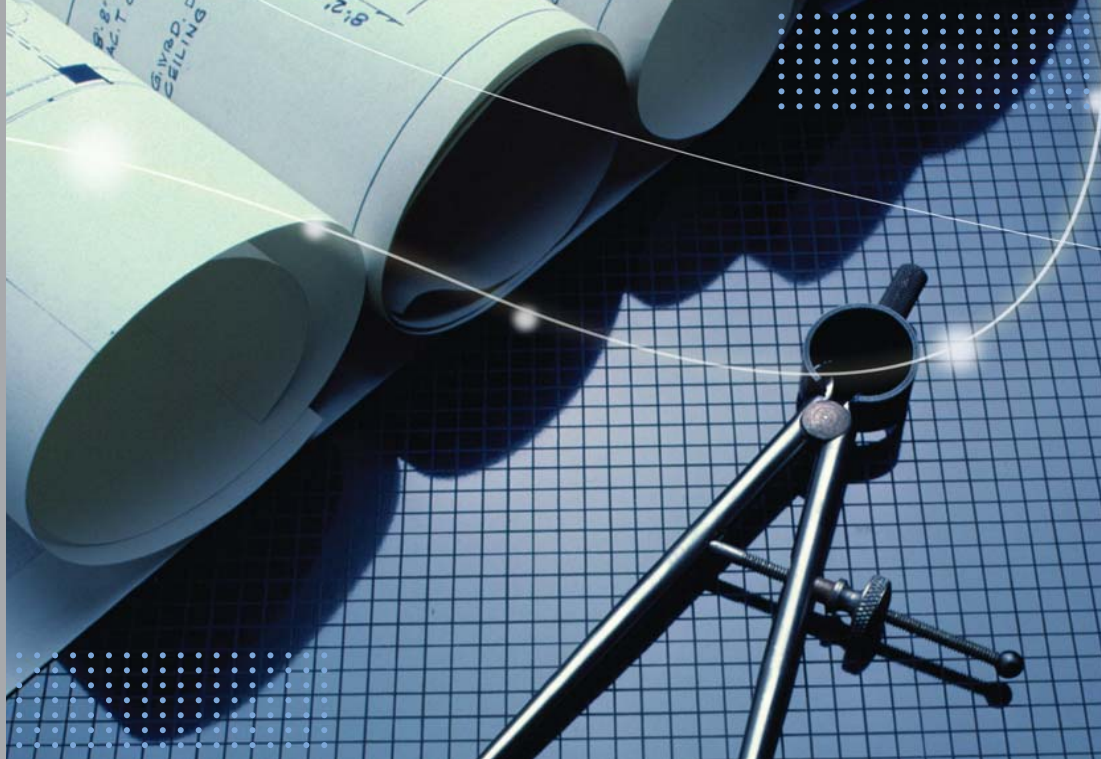

# Contents

- 3 Lining Materials
- 4 Pipe
- 5 90° Elbow
- 6 45° Elbow
- 7 Equal Tee
- 8 Reducing Tee
- 9 Concentric Reducer / Eccentric Reducer
- 10 Instrument Tee
- 11 Expansion Joint / PFA Tube

## Lining Materials

### PFA

PFA exhibits thermal characteristics like to PTFE, being able to withstand super low to high temperatures (260°C Maximum temp. for continuous use). It is also transparent and mechanically strong under high temperature. It is easily workable besides applicable with extrusion molding to the same degree as general thermoset plastics. It is used where purity is important, such as semiconductor wafer baskets, piping couplings and non-corrosive linings. PFA has better mechanical strength at high temperatures than FEP, and excellent moldability for easy processing by extrusion, compression, blow, transfer and injection molding methods. Due to the high bonding strength of the carbon, fluorine and oxygen atoms, PFA demonstrates nearly the same outstanding capabilities as PTFE in temperatures ranging from -200°C to +260°C.

### FEP

FEP is a copolymer of tetrafluoroethylene and hexafluoropropylene, FEP consists of carbon atoms and fluorine atoms, as does PTFE, and has a molecular structure in which one of the fluorine atoms bonded to the carbon atoms. FEP has a lower melt viscosity than PTFE and can be processed like other molten thermoplastic resins by extrusion, transfer, injection, and compression molding. Because the bonding energy between its carbon and fluorine atoms is so high, and because the carbon chain is completely surrounded by fluorine atoms, FEP fluorocarbon polymer retains excellent thermal, electrical, and chemical stability. Therefore, it shows high performance in electrical, chemical, and medical applications in temperatures ranging from extremely low to extremely high (-200°C ~ +200°C / -328°F ~ +392°F).

### PTFE

The fluorine atoms completely cover the carbon chain backbone and protect the carbon-carbon bond from attack. The fluorine atoms are also responsible for the low surface energy and exceptional frictional characteristics of PTFE. Because of very high melt viscosity, PTFE does not flow above its melting point. It requires special polymer processing like paste extrusion, compression molding and sintering. Among all the fluoroplastics products, PTFE offers the highest heat resistances at 260°C (maximum temp. for continuous use). It is not corroded by most chemicals and has good electrical insulation and dielectric characteristics. Moreover, it has a unique non-stick property and the lowest coefficient of friction amongst solids. It is the most widely used fluoroplastics, now found in O-rings, gaskets, bearings, tube, wiring, hot plates and irons because of its non-stick property, as well as chemical tank linings.

Property	PFA			FEP			PTFE		
	Testing Method	Value	Unit	Testing Method	Value	Unit	Testing Method	Value	Unit
Specific Gravity	ASTM D-3307	2,14-2,16	—	ASTM D-2116	2,12-2,17	—	ASTM D-3307	2,14-2,20	—
Melt Flow Rate	ASTM D-3307	7-8	g/10 min	ASTM D-2116	6	g/10 min	—	—	—
Melting Point	ASTM D-3307	304	°C	ASTM D-2116	260	°C	ASTM D-3307	327	°C
Tensile Strength	ASTM D-3307	33,3 (4835)	MPa (psi)	ASTM D-2116	31	MPa (psi)	ASTM D-3307	13,7-34,3 (1990-4980)	MPa (psi)
Elongation	ASTM D-3307	420	%	ASTM D-2116	370	%	ASTM D-3307	200-400	%
Chemical resistance	—	Excellent		ASTM D-2116	Excellent		—	Excellent	—

## Pipe

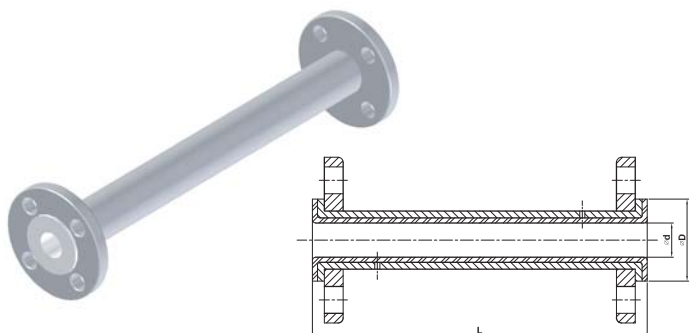

(unit : mm)

Nominal size	L(Max)	φ d	φ D		Lining thickness	Ref.
			ANSI 150	JIS 10K		
1/2 (15A)	3000	10	35	51	3	A
3/4 (20A)	3000	15	43	56	3	B
1 (25A)	3000	21	51	67	3	C
1 1/2 (40A)	3000	35	73	81	3	D
2 (50A)	3000	46.5	96	96	3.2	E
2 1/2 (65A)	3000	58.5	104.5	116	3.2	F
3 (80A)	3000	71	129	126	3.5	G
4 (100A)	3000	94	160	151	4	H
5 (125A)	3000	120	186	182	4	I
6 (150A)	3000	146	218	212	4	J
8 (200A)	3000	186	270	262	4	K
10 (250A)	3000	244	324	324	5	L

※ Note : 1/2"~3" 6000(L) Possible

## Ordering information

Connection	Ref.	Pipe body materials	Ref.	Surface finish	Ref.
JIS 10K	J	PTFE lined Carbon steel	TW	Painting	P
ANSI 150lbs	A	PTFE lined Stainless Steel	TS	Acid cleaning	AC
		PFA lined Carbon steel	W		
		PFA lined Stainless steel	S		

Order example	J	P	C	S	AC
Connection	J				
Type		P			
Nominal size			C		
Pipe body material				S	
Surface finish					AC

## 90° Elbow

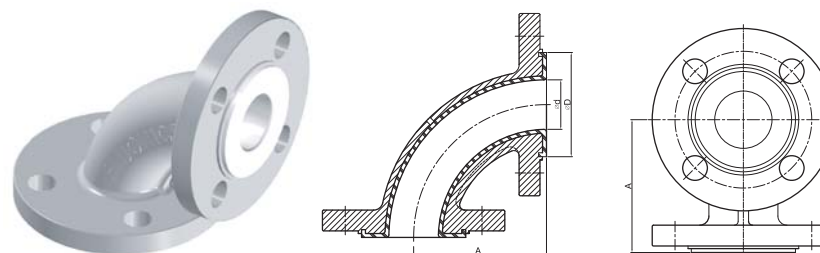

(unit : mm)

- Lining thickness : According to ASTM F1545(Min 2,54mm)
- One side & Two side lap joint available

Nominal size	A	φ d		φ D	Ref.
		★	●		
1/2 (15A)	80	20	15	40	A
3/4 (20A)	80	20	15	50	B
1 (25A)	89	25	19	57	C
1 1/2 (40A)	102	38	29	76	D
2 (50A)	114	50	42	95	E
2 1/2 (65A)	130	64	-	113	F
3 (80A)	140	76	79	125	G
4 (100A)	165	100	90	150	H
6 (150A)	203	143	130	212	J
8 (200A)	229	190	181	260	K
10 (250A)	279	-	-	318	L

★ Casting type dimensions ● Welding type dimensions

## Ordering information

Connection	Ref.	Fitting body materials	Ref.	Surface finish	Ref.
JIS 10K	J	PFA lined Carbon Steel	W	Painting	P
ANSI 150lbs	A	PFA lined Stainless Steel	S	Acid cleaning	AC
		PTFE lined Carbon Steel	TW		
		PTFE lined Stainless Steel	TS		

Order example	J	90L	C	S	AC
Connection	J				
Type		90L			
Nominal size			C		
Fitting body material				S	
Surface finish					AC

## 45° ELBOW

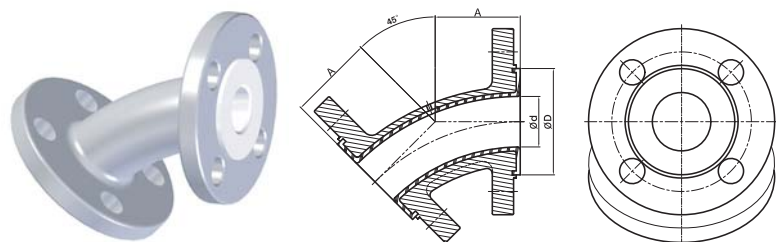

(unit : mm)

Nominal size	A	φ d		φ D	Ref.	
		★	●			
PFA	1/2 (15A)	45	25	-	40	A
	3/4 (20A)	45	25	-	50	B
	1 (25A)	45	25	-	57	C
	1 1/2 (40A)	57	38	-	76	D
	2 (50A)	64	45	-	95	E
	3 (80A)	76	70	-	127	G
	4 (100A)	102	95	-	150	H
	6 (150A)	131	148.9	-	212	J

★ Casting type dimensions ● Welding type dimensions

## EQUAL TEE

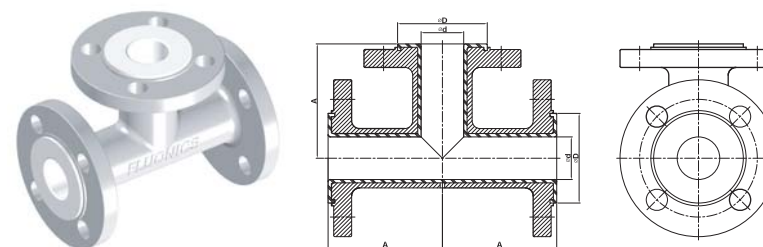

(unit : mm)

Nominal size	A	φ d		φ D	Ref.	
		★	●			
PFA	1/2 (15A)	80	17	17	40	A
	3/4 (20A)	80	17	17	50	B
	1 (25A)	89	25	20	57	C
	1 1/2 (40A)	102	38	33	76	D
	2 (50A)	114	50	41	95	E
	2 1/2 (65A)	130	65	58	113	F
	3 (80A)	140	76	70	125	G
	4 (100A)	165	100	88	150	H
	6 (150A)	203	143	138	212	J
	8 (200A)	229	-	190	260	K

★ Casting type dimensions ● Welding type dimensions

## Ordering information

Connection	Ref.	Fitting body materials	Ref.	Surface finish	Ref.
JIS 10K	J	PFA lined Carbon Steel	W	Painting	P
ANSI 150lbs	A	PFA lined Stainless Steel	S	Acid cleaning	AC
		PTFE lined Carbon Steel	TW		
		PTFE lined Stainless Steel	TS		

Order example	J	45L	C	S	AC
Connection	J				
Type		45L			
Nominal size			C		
Fitting body material				S	
Surface finish					AC

## Ordering information

Connection	Ref.	Fitting body materials	Ref.	Surface finish	Ref.
JIS 10K	J	PFA lined Carbon Steel	W	Painting	P
ANSI 150lbs	A	PFA lined Stainless Steel	S	Acid cleaning	AC
		PTFE lined Carbon Steel	TW		
		PTFE lined Stainless Steel	TS		

Order example	J	E	C	S	AC
Connection	J				
Type		ET			
Nominal size			C		
Fitting body material				S	
Surface finish					AC



## Reducing Tee

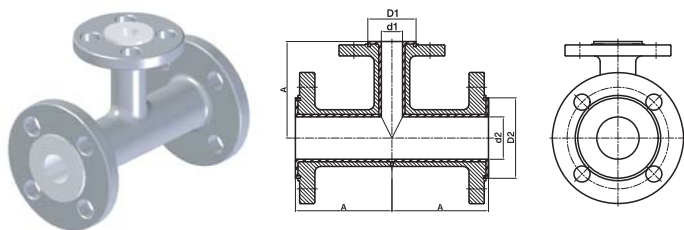

(unit : mm)

Size Availability	ø D2	ø d2		ø D1	ø d1		A	Ref.
		★	●		★	●		
1 x 3/4	57	25	20	50	20	16	89	CB
1 1/2 x 3/4	76	38	33	50	20	16	102	DB
1 1/2 x 1	76	38	33	57	25	20	102	DC
2 x 1	95	50	41	57	25	20	114	EC
2 x 1 1/2	95	50	41	76	38	33	114	ED
2 1/2 x 1 1/2	113	-	58	76	-	33	130	FD
2 1/2 x 2	113	-	58	95	-	38	130	FE
3 x 1 1/2	125	76	70	76	38	33	140	GD
3 x 2	125	76	70	95	50	38	140	GE
4 x 2	150	100	88	95	50	38	165	HE
4 x 3	150	-	88	125	-	65	165	HG
6 x 3	212	143	138	125	76	63	203	JG
6 x 4	212	143	138	150	100	88	203	JH
8 x 4	260	-	190	150	-	88	229	KH
8 x 6	260	-	190	212	-	138	229	KJ
10 x 4	318	-	231	150	-	88	279	LH

★ Casting type dimensions ● Welding type dimensions

## Concentric Reducer / Eccentric Reducer

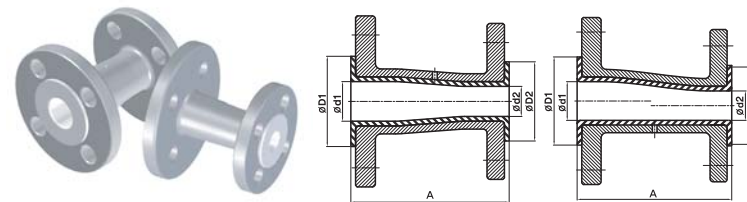

(unit : mm)

Size Availability	ø D1	ø d1		ø D2	ø d2		A	Ref.
		ECC	CON		ECC	CON		
1 x 3/4	57	20	19	50	13	13	100	CB
1 1/2 x 3/4	76	33	33	50	13	13	100	DB
1 1/2 x 1	76	33	33	57	20	19	100	DC
2 x 1	95	46	46	57	18	19	127	EC
2 x 1 1/2	95	46	46	76	33	33	127	ED
2 1/2 x 1 1/2	113	58	59	76	33	33	127	FD
2 1/2 x 2	113	58	59	95	41	41	127	FE
3 x 1 1/2	125	70	66	76	33	33	152	GD
3 x 2	125	68	66	95	41	41	152	GE
4 x 2	150	93	88	95	41	41	152	HE
4 x 3	150	86	88	125	58	65	152	HG
6 x 3	212	140	136	125	58	61	200	JG
6 x 4	212	140	136	150	81	76	200	JH
8 x 4	260	190	184	150	85	80	200	KH
8 x 6	260	185	184	212	133	135	200	KJ
10 x 4	318	-	234	150	-	88	200	LH
2 x 3/4 (CON)	95	-	46	-	-	15	127	EB
3 x 1 (CON)	125	-	70	-	-	20	152	GC
4 x 1 1/2 (CON)	150	-	93	-	-	35	152	HD

## Ordering information

Connection	Ref.	Fitting body materials	Ref.	Surface finish	Ref.
JIS 10K	J	PFA lined Carbon Steel	W	Painting	P
ANSI 150lbs	A	PFA lined Stainless Steel	S	Acid cleaning	AC
		PTFE lined Carbon Steel	TW		
		PTFE lined Stainless Steel	TS		

Order example	J	RT	CB	S	AC
Connection	J				
Type		RT			
Nominal size			CB		
Fitting body material				S	
Surface finish					AC

## Ordering information

Connection	Ref.	Fitting body materials	Ref.	Surface finish	Ref.
JIS 10K	J	PFA lined Carbon Steel	W	Painting	P
ANSI 150lbs	A	PFA lined Stainless Steel	S	Acid cleaning	AC
		PTFE lined Carbon Steel	TW		
		PTFE lined Stainless Steel	TS		

Order example	J	CON or ECC	CB	S	AC
Connection	J				
Type		CON or ECC			
Nominal size			CB		
Fitting body material				S	
Surface finish					AC

## Instrument Tee

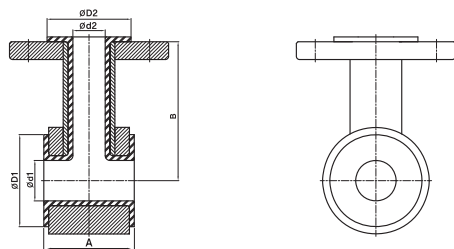

(unit : mm)

Size Availability	A	B	∅ D1	∅ d1	∅ D2	∅ d2	Ref.	
PFA	1 1/2 x 3/4	50	102	69	35	50	17	DB
	1 1/2 x 1	50	102	39	35	57	17	DC
	2 x 3/4	50	114	88	45	50	17	EB
	2 x 1	50	114	88	45	57	17	EC
	2 1/2 x 3/4	50	123	113	59	50	17	FB
	2 1/2 x 1	50	123	113	59	57	17	FC
	3 x 3/4	50	140	123	69	50	17	GB
	3 x 1	50	140	123	69	57	17	GC
	4 x 3/4	50	165	151	94	50	17	HB
	4 x 1	50	165	151	94	57	17	HC
	6 x 3/4	50	203	209	140	50	17	JB
	6 x 1	50	203	209	140	57	17	JC
	8 x 3/4	50	229	260	190	50	17	KB
	8 x 1	50	229	260	190	57	17	KC

## Ordering information

Connection	Ref.	Fitting body materials	Ref.	Type of production	
JIS 10K	J	PFA lined Carbon Steel	W	Casting type	CT
ANSI 150lbs	A	PFA lined Stainless Steel	S	Welding type	WT
		PTFE lined Carbon Steel	TW		
		PTFE lined Stainless Steel	TS		

Order example	J	IT	DB	S	AC
Connection	J				
Type		IT			
Nominal size			DB		
Fitting body material				S	
Surface finish					AC

## Expansion Joint

Nominal size	I.D	Neutral length		Extension/Compression		Angular movements		Lateral movement		Ref.
		3convolutions	5convolutions	3convolutions	5convolutions	3convolutions	5convolutions	3convolutions	5convolutions	
1 (25A)	24	47	80	12	20	30°	36°	10	15	C
1 1/2 (40A)	37	67	100	12	20	28°	34°	15	20	D
2 (50A)	46	71	100	15	25	26°	28°	15	20	E
2 1/2 (65A)	60	83	117	22	35	20°	22°	17	30	F
3 (80A)	70	88	130	25	40	16°	20°	17	30	G
4 (100A)	98	93	143	25	40	16°	20°	17	30	H
6 (150A)	145	104	165	28	45	12°	14°	18	32	J
8 (200A)	196	100	220	28	45	12°	14°	20	32	K
10 (250A)	242	175	230	28	45	12°	14°	10	15	L

## Ordering information

Connection	Ref.	Fitting body materials	Ref.	Surface finish	Ref.
JIS 10K	J	PTFE+Carbon Steel Flange	W	Painting	P
ANSI 150lbs	A	PTFE+Stainless Steel Flange	S	Acid cleaning	AC

Order example	J	EX	C	S	AC
Connection	J				
Type		EX			
Nominal size			C		
Fitting body material				S	
Surface finish					AC

## PFA Tube



(unit : mm)

Products	Nominal O.D	O.D tolerance	Wall th'k	Wall tolerance	Length	Length tolerance
T-1/4 Tube	6,35	+/-,102	1,194	+/-,102	100M	+2% -0
	9,53	+/-,102	1,574	+/-,127		
	12,70	+/-,127	1,574	+/-,127		
	19,05	+/-,127	1,574	+/-,127		
	25,40	+/-,127	1,574	+/-,127		
	40,00	+/-,203	2,184	+/-,127		
	50,80	+/-,203	2,590	+/-,203		
	P-1/2 Pipe	21,34	+/-,127	2,768		
26,67		+/-,254	2,870	+/-,254		
33,40		+/-,381	3,378	+/-,381		
60,33		+/-,508	3,911	+/-,381		

(unit : mm)

Products	Nominal O.D	O.D tolerance	Wall th'k	Wall tolerance	Length	Length tolerance
T-1/4 Tube	0,250	+/-,004	0,047	+/-,004	328 ft	+2% -0
	0,375	+/-,004	0,062	+/-,005		
	0,500	+/-,005	0,062	+/-,005		
	0,750	+/-,005	0,062	+/-,005		
	1,000	+/-,005	0,062	+/-,005		
	1,575	+/-,008	0,086	+/-,005		
	2,000	+/-,008	0,102	+/-,008		
	P-1/2 Pipe	0,840	+/-,005	0,109		
1,050		+/-,010	0,113	+/-,010		
1,315		+/-,015	0,133	+/-,015		
2,375		+/-,020	0,154	+/-,015		