

This product is represented in Australia, New Zealand, and PNG by:

InKorr Pty Ltd

Address: Unit 12, 103 Lewis Road,
Knoxfield VIC 3180, Australia

Email: inkorr.service@inkorr.com.au

General: +61 (3) 8201 4868

Service: +61 (0) 478 800 003

Contact us with any enquiries related to:



Heat Transfer Equipment

- Shell & Tube Heat Exchangers - Standard, Custom, Corrugated Tubes.
- Plate Heat Exchangers - Brazed, Gasketed, Semi-Welded, & Welded.
- Graphite Heat Exchangers.
- Plate & Shell Heat Exchangers.
- Spiral Heat Exchangers.
- Crossflow Welded Heat Exchangers.
- Direct Steam Injection Heaters.
- Air Coolers.



Corrosion Resistant Equipment - Valves, Piping, Vessels & Systems

- Polymer-Lined Valves, Piping, and Pressure Vessels.
- Exotic Metal (Ta, Zr, Ti) Fabricated Piping and Pressure Vessels.
- Glass-Lined Vessels.
- Graphite Equipment and System Packages.

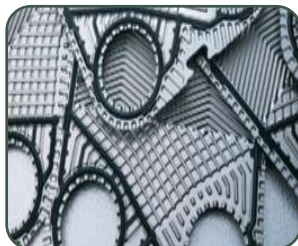

Service Maintenance

- Plate Heat Exchangers - Refurbishment, Gas Testing, UV Crack Testing.
- Graphite Equipment - Installation, Refurbishment, Repairs.
- Glass-Lined Vessels - Spark Testing, Lining Repair.
- Quality Spare Parts, both OEM and Aftermarket.



Process Heating Solutions Worldwide

Pulp & Paper Industry Case History

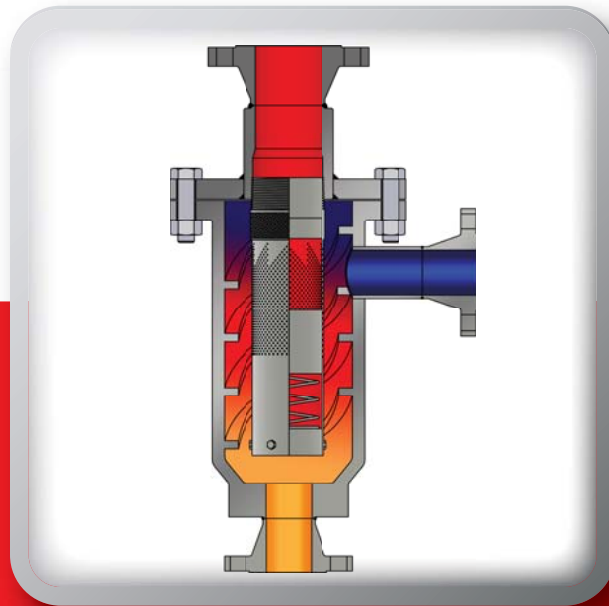

Starch Cooking

Application

A converting mill producing a range of specialty coated printing and copier papers, required a steam injection heater for cooking cationic starch slurry, up to 35% solids. The heater serves a dual function. First, water is pre-heated to 140°F and blended with starch powder. Then the starch slurry is pumped back through the heater at a rate of 40 GPM and cooked at 200°F. Depending on the recipe, post dilution is used to obtain final consistency.

Process Conditions

Slurry and Water Flow Rate:	40 GPM
Inlet Temperature:	50°F
Final Cook Temperature:	200°F
Steam Pressure:	65 PSIG
Water Pressure:	50 PSIG
Required Steam Flow:	2,580 lb/hr

Solution

A **Pick Model 6X25-3BX Heater** was selected for this application. Its generous flow-through design imposes negligible pressure drop on the slurry. It provides thorough cooking at a precisely controlled temperature. The low velocity design minimizes mechanical shear of the starch granules, an important factor for most cationic starches.

Features and Benefits:

- Low Pressure Drop
- Precise Temperature Control
- Low Mechanical Shear
- Compact Design
- Non-Plugging

Learn more at www.pickheaters.com

Pick Heaters, Inc. — 730 S. Indiana Ave. — West Bend, WI 53095 USA
Phone: (262) 338-1191 — Email: info1@pickheaters.com