



**I N T E R N A T I O N A L**

OVER 40 YEARS OF INNOVATION, QUALITY, SAFETY.

# **OWNERS MANUAL**

**Part: A8102, A8103, A8104, A8105, A8106**

## **GlowStep Revolution**

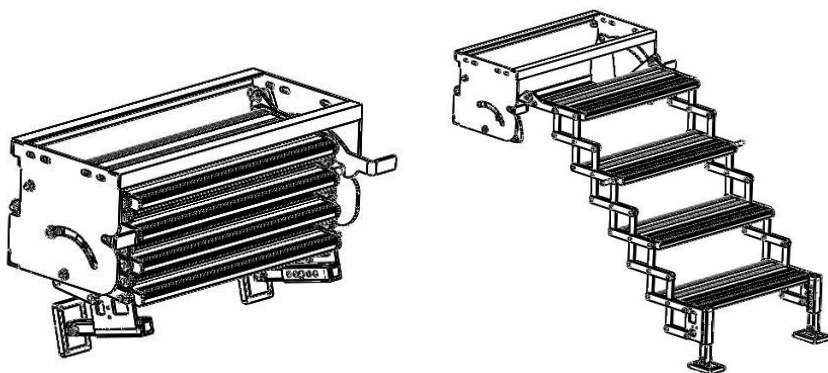

Version 18 BY: CW 8-21-2018

**TECH SUPPORT (800) 246-8132**

**AFTER INSTALL, PLEASE GIVE  
THIS BOOKLET TO YOUR CUSTOMER**

## **GlowStep Revolution User Guide**

How to quickly and effectively **lower** your GlowStep Revolution

# GlowStep Revolution User Guide

How to quickly and effectively **raise** your GlowStep Revolution

## Step 1:



Remove **safety pin**.

## Step 2A:



Completely **collapse\*** steps by picking up bottom step and walking in toward the RV.

## Step 2B:



**TIP:**  
Use your thigh to assist when collapsing the steps.

## Step 3:



With the steps fully collapsed, lift handle and **rotate steps** up and inward while guiding the guide pins into the guide slots located on both sides of the mounting cage until step stores into place in the stored position.



## Step 4:









As steps roll in, release the handle. When the handle drops into place, reattach **safety pin** to secure steps.

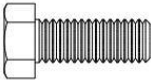
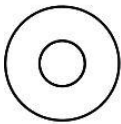

**\* Steps must be completely collapsed to store properly**

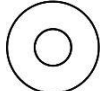
If you would like further information or would like to purchase the GlowStep Revolution please feel free to give us a call at **800.246.8132** and we will be happy to assist you.

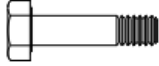
## Parts Inventory (Hardware in Bolt Kit)

<b>Item Image</b>	<b>Item Description</b>	<b>Item #</b>	<b>Qty</b>
	3/8"-16 x 1-1/2" Grade 5 Hex Bolt	6031	4
	3/8" SS SAE Flat Washers	8949	8
	3/8" Lock Washers	6003	4
	3/8"-16 Grade 5 Hex Nuts	3306	4
	5/16"- 18 x 1.25" Grade 5 Hex Bolts	3600	4
	5/16"-18 Grade 5 Hex Nut	3561	4
	5/16" USS Flat Washer	6025	8
	5/16" Lock Washer	3507	4
	7/32 Hex L Key	11793	1
	1/4"-20 x 1-1/16" Hex Bolt	10978	2

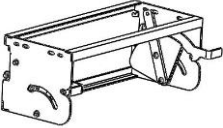
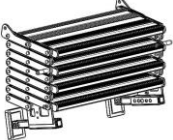
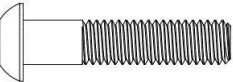
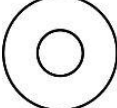
## Parts Inventory (Hardware Preassembled)

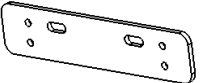
Item Image	Item Description	Item #	Qty
	GlowStep Revolution Frame (assembled)		1
	GlowStep Assembly (assembled)		1
	3/8"-16 x 1-3/4" Button Head Socket Cap Screw (Pre-Assembled)	11794	2
	3/8" SS SAE Flat Washers (Pre-Assembled)	8949	4
	3/8"-16 Grade 8 Nylock Hex Nut (Pre-Assembled)	10613	2
	3/8" x 3/4" x 3/8" Nylon Spacer (Pre Assembled)	11747	2
	GSR Spacer Plate	A8020- P1	2

**Important Note:** If your factory step is attached by studs that drop through the floor of the trailer or does not have vertical mounting brackets that would be left behind after removing the OEM step, you will need bracket part number A8022 in conjunction with your step part number. Please call a Torklift Representative for more details.

# Step 1

Begin by removing the factory steps, and leveling the trailer on flat ground.

# Step 2

Determine the proper mounting height of the GlowStep Revolution Frame. The top of the GlowStep Revolution Frame should sit as close to the optimal mounting height as possible to allow for the most adjustability when installed.

Refer to *table 2.1* for the optimal mounting height as measured from the ground to the top of the GlowStep Revolution Frame when the trailer is leveled on flat ground.

Part Number	Mounting Height (inches)/(cm)
A8102	20.25 / 51.4
A8103	27.75 / 70.5
A8104	35.25 / 89.5
A8105	42.75 / 108.5
A8106	50.25 / 127.6

**Table 2.1**

Due to the variances in step opening and door heights, it may be necessary to deviate from the optimal mounting height. The top of the GlowStep Revolution frame should sit no lower than five inches from the threshold of the door.

Based on the mounting height of your trailer, it may be necessary to add or remove a step. See page 16 for further details.

If two people are installing the GlowStep Revolution, then proceed to Step 3A. If one person is installing the GlowStep Revolution, then proceed to Step 3B.

# Step 3A

Unfold the GlowStep Revolution as is seen in *Figure 3.1A*. One person can hold the GlowStep Revolution Frame in place as needed while the hardware is installed. The feet should be resting on the ground to reduce the weight that is being held by the person. Proceed to step 4.

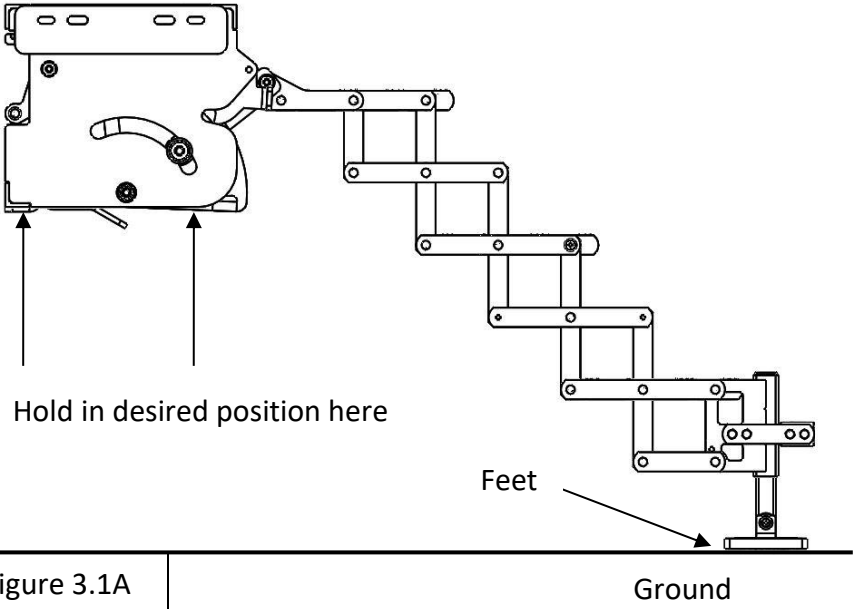
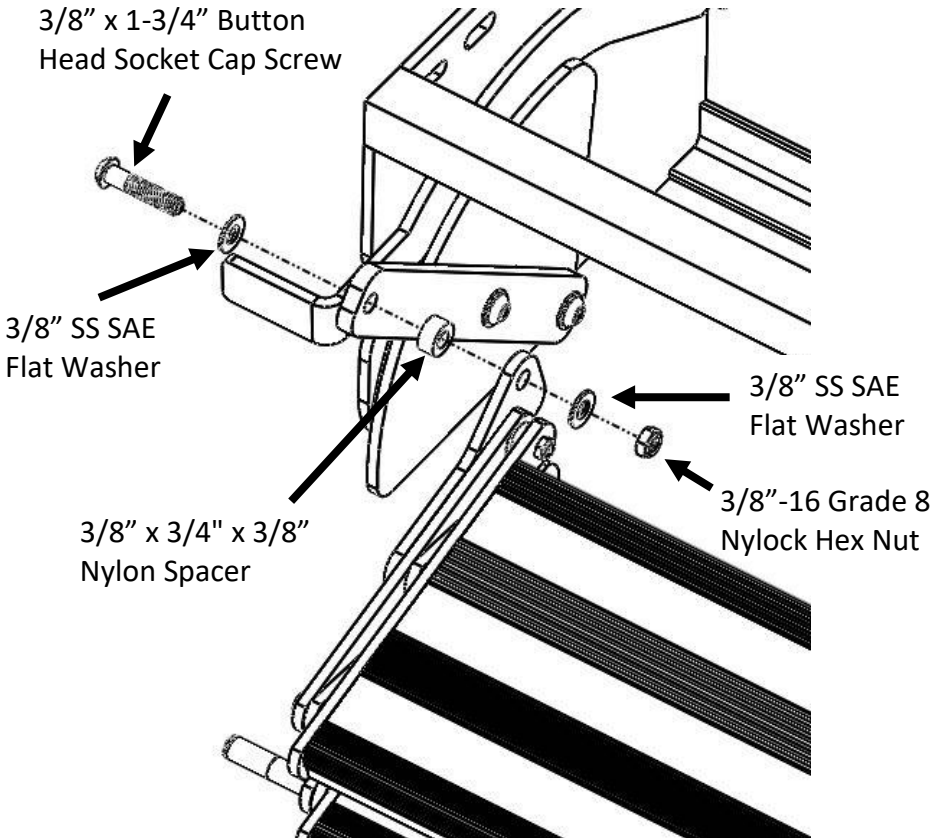

Figure 3.1A

## Step 3B

Remove the GlowStep Revolution from the packaging. Lift one of the step release levers and pull the GlowStep assembly out from the GlowStep Revolution Frame. Remove the hardware attaching the GlowStep assembly to the pivot arms as shown in *figure 3.1B*, using the included **Hex L-Key**. Save this hardware, as it will be used later to reattach the steps.

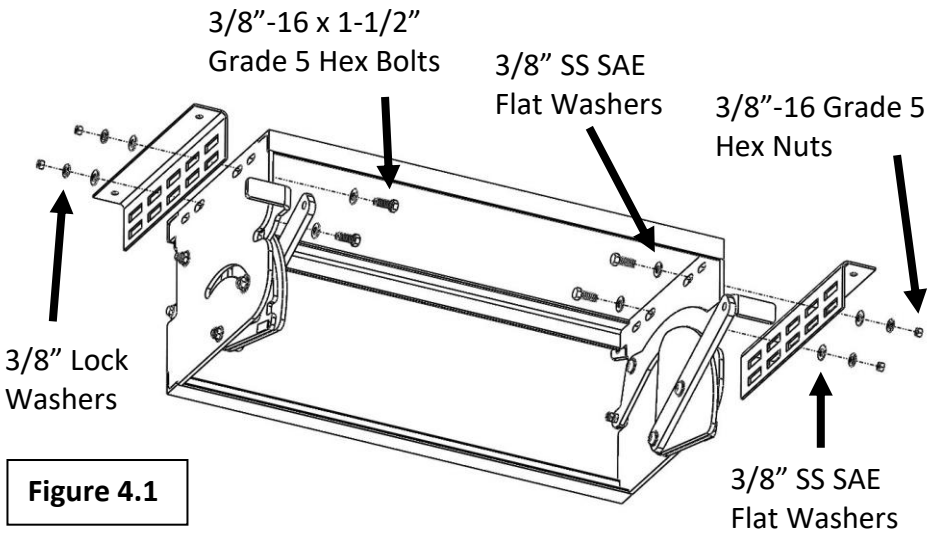

**Figure 3.1B**

## Step 4

The GlowStep Revolution Frame can be mounted with either 3/8" hardware through the inner holes as seen in *figure 4.1*, or mounted with 5/16" hardware through the outer holes as seen in *figure 4.2*. Side brackets vary by manufacturer, and may need to be trimmed to clear the hardware protruding through the sides of the GlowStep Revolution Frame. If the width of your camper mounting brackets is wider than the GlowStep Revolution frame, use **the GSR Spacer Plate** to increase the mounting width of the GlowStep Revolution.

Once installed, torque the 3/8" hardware to 25 ft-lbs, or torque the 5/16" hardware to 15 ft-lbs.





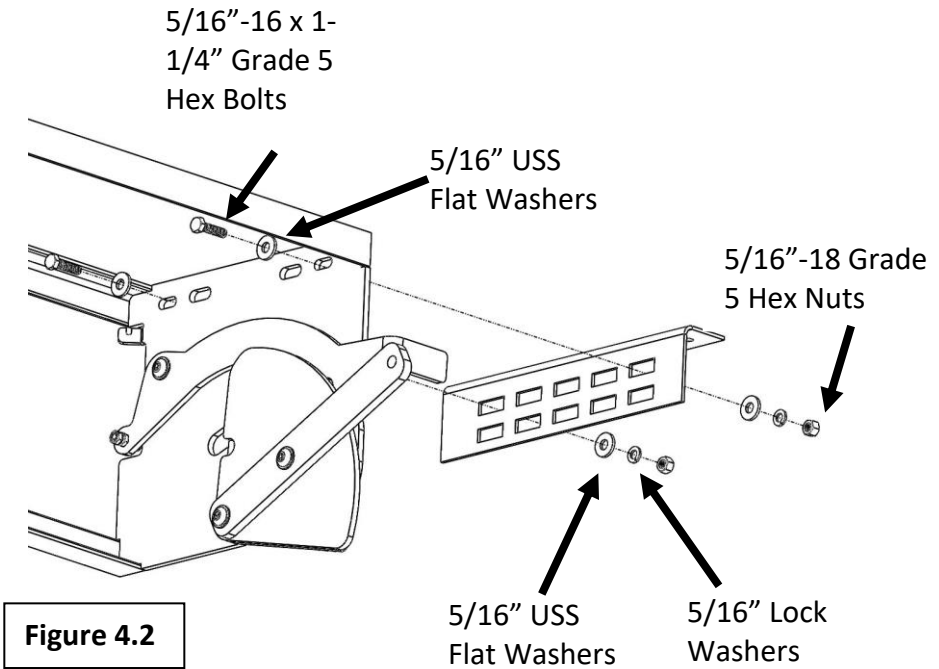

## Step 5 - Reattach GlowSteps

If the GlowSteps were removed for installation, the GlowStep assembly can be reattached to the pivot arms at this time. See *figure 3.1B*.

Snug the 3/8"-16 Gr8 Nylock Nuts, then back them off approximately 1/4 turn. The steps should be able to pivot around the bolt.

# Step 6: Adjusting the GlowStep Revolution

The GlowStep Revolution is height adjustable to match the terrain the trailer is parked on. The GlowStep Revolution frame has three adjustment points: High, Medium, and Low. If mounted at the optimal height (see table 2.1), the GlowStep Revolution should be set at the medium height when the trailer is leveled on flat ground.

Since camp sites are rarely level, the top step can be raised or lowered 2" by moving the GlowStep Revolution frame into the High or Low position. This is accomplished by lifting one of step release levers, and then moving the steps in or out of the GlowStep Revolution frame until the locking mechanism locks into the next position. See *figure 6.1*.

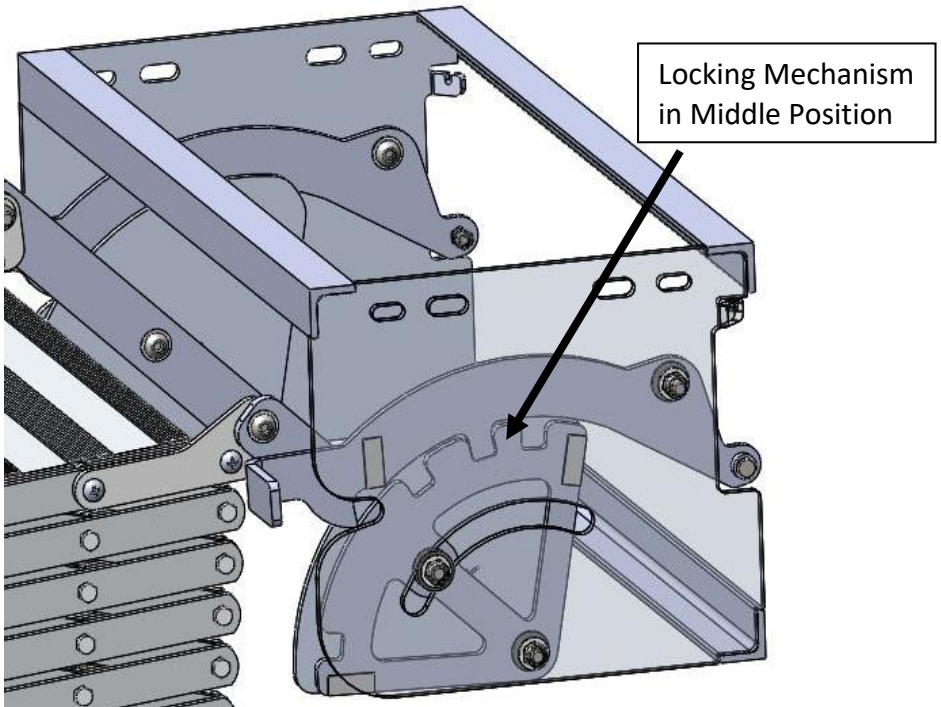
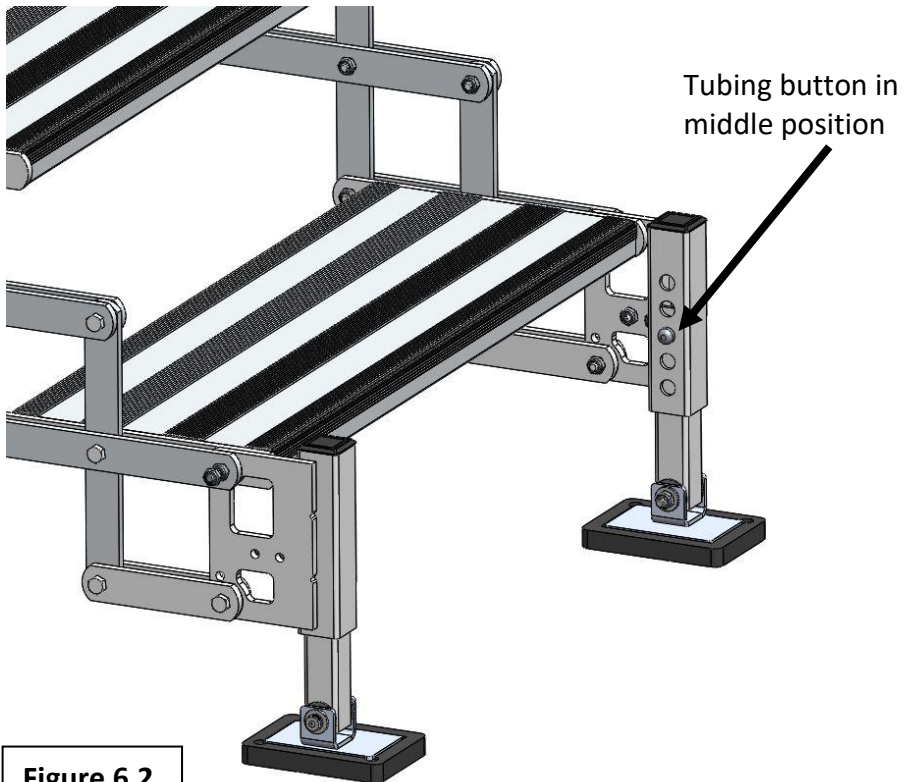

**Figure 6.1**

Further adjustments can be made at the All Terrain Landing Gear located at the bottom of the steps. From the middle position, the All Terrain Landing Gear can be adjusted up or down as much as 1-1/2" by changing the location of the push buttons on the side of the vertical tubes.

The steps do not need to sit perfectly parallel to the ground to be functional. The All Terrain Landing Gear feet may be adjusted independently to match uneven ground surfaces.

**The 1/4" x 1-3/8" Bail Pin MUST be installed in the passenger or driver side step release lever before using the steps. See *figure 6.4*.**



**Figure 6.2**

# Storing the GlowStep Revolution

To store the GlowStep Revolution, lift either step release lever, and pull the GlowSteps out until the GlowStep Revolution frame is in either the Medium or Low position. Lift the bottom step up until roughly even with the top step. Push the bottom step towards the top step, collapsing the GlowStep assembly.

Lift one of the step release levers, and, with the steps angled down, push the GlowStep assembly up and into the GlowStep Revolution Frame. It is best to push up from the bottom step.

In order to prevent damage, the **STEPS MUST BE FULLY COLLAPSED** before being stored. Four, Five, and Six step units have a shelf at the back of the GlowStep Revolution frame, which will keep the steps from expanding when stored.

Guide the nylon studs (located on the second step from the top) into the latches on either side of the GlowStep Revolution Frame. See *Figure 6.2*. Once the latches close around the nylon studs and insert the Pin through the handle to fully secure the steps. See *Figure 6.3*.

The nylon studs will not fully engage the latches unless the steps are completely collapsed.

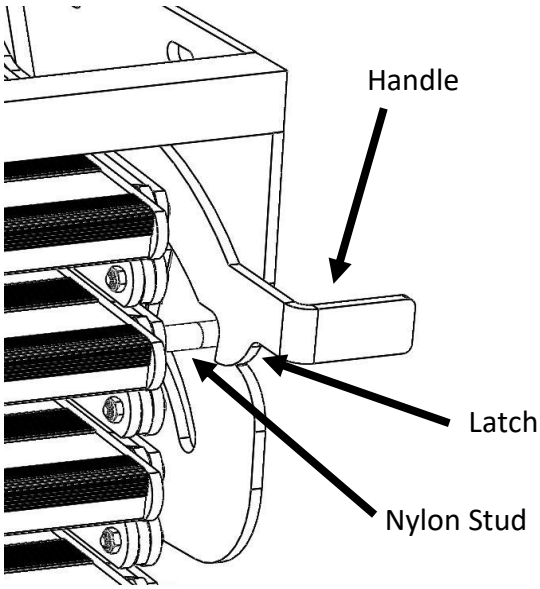

**Figure 6.2**

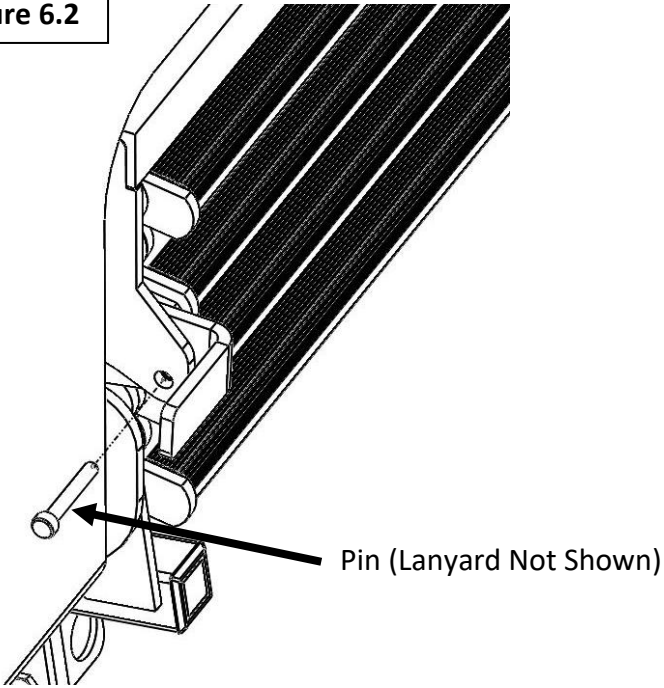

**Figure 6.3**

# Deploying the GlowStep Revolution

To deploy the GlowStep Revolution, remove the Pin in the left side release lever. Lift one of the levers, and begin to pull the GlowStep assembly out. Pull from the top step to keep the steps from angling up on their way out. Once past the locking detent, release the lever. The locking mechanism is spring loaded and will automatically lock the GlowSteps into the High position. Repeat this process to move the step into the Medium position.

Once the GlowStep Revolution is in the Medium position, **push the steps back towards the GlowStep Revolution Frame to make sure the locking mechanism is fully engaged.**

Pull the bottom step away from the GlowStep Revolution Frame to extend the steps, then place the All-Terrain Landing Gear feet on the ground. If the steps need to be adjusted, begin by adjusting the upper step at the GlowStep Revolution Frame into either the High or Low position, then adjust the All Terrain Landing Gear. Once the step is in the proper position, use the Pin to secure the left side release lever. See *Figure 6.4*.

**The Pin MUST be installed before using the steps.**

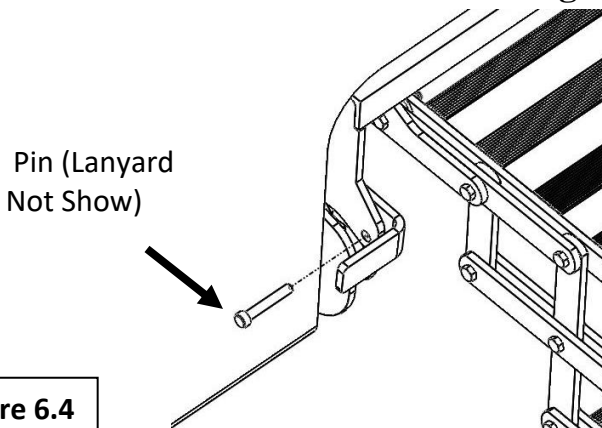

**Figure 6.4**

# Step 7: GlowStep Revolution Hinge Tension Adjustment

Your GlowStep Revolution Steps come from the factory preset to a specific torque setting. This can be adjusted to suit your personal preference for ease of use if needed. The Hinge Tension Adjustment bolts are circled in *Figure 7.1*. In order to tighten or loosen the steps simply take two 7/16" wrenches and locate two outside bolts in-between each of the steps. Turn the bolts in increments of 1/32-1/16 turns at a time starting at the top then alternating to the other suggested bolts until complete.

**Caution:** Do not over tighten any one bolt as this causes accelerated wear. When your step is set to your liking, it should begin to slowly open when disengaged from the frame. If it opens and contacts the ground without assistance the steps are too loose.

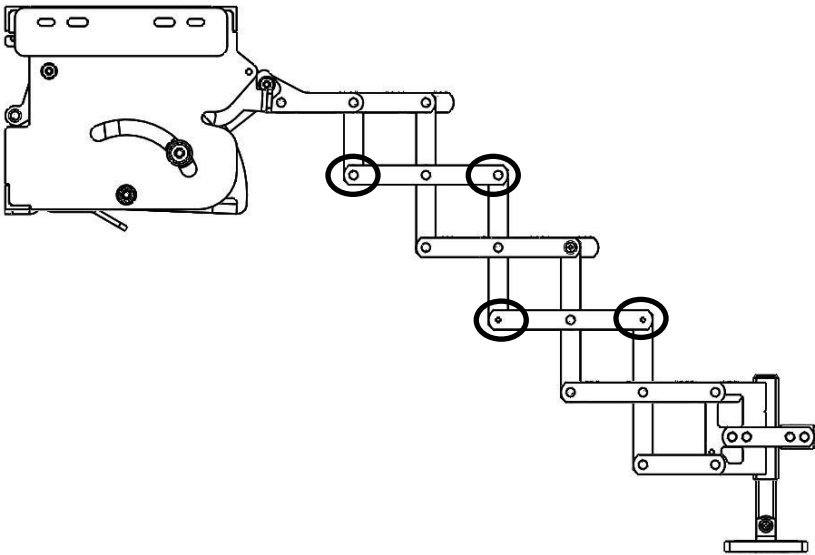
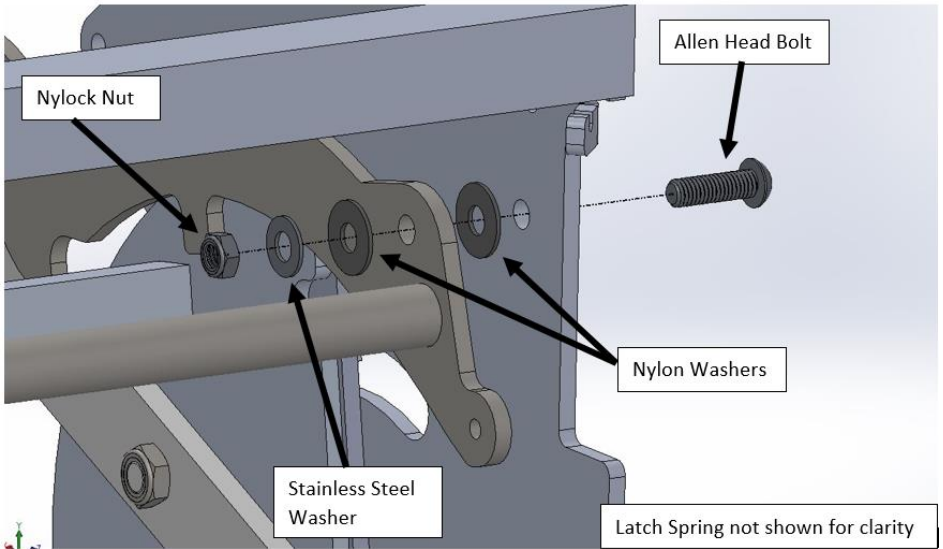

Figure 7.1

## Step 8: Step Release/Lowering Lever Hinge Tension Adjustment

Due to shipping if for any reason the auto return spring tension of the release lever is binding or is not operating adequately, it can easily be adjusted using one 9/16 wrench and one 7/32 Allen wrench. The bolt is located at the back of the GlowStep Revolution cage directly in front of the tensions spring as seen in the photos below. Adjust the 9/16 nut one 1/4 turn at a time and recheck tension of the release lever so that it automatically drops back into the down or locked position when released.





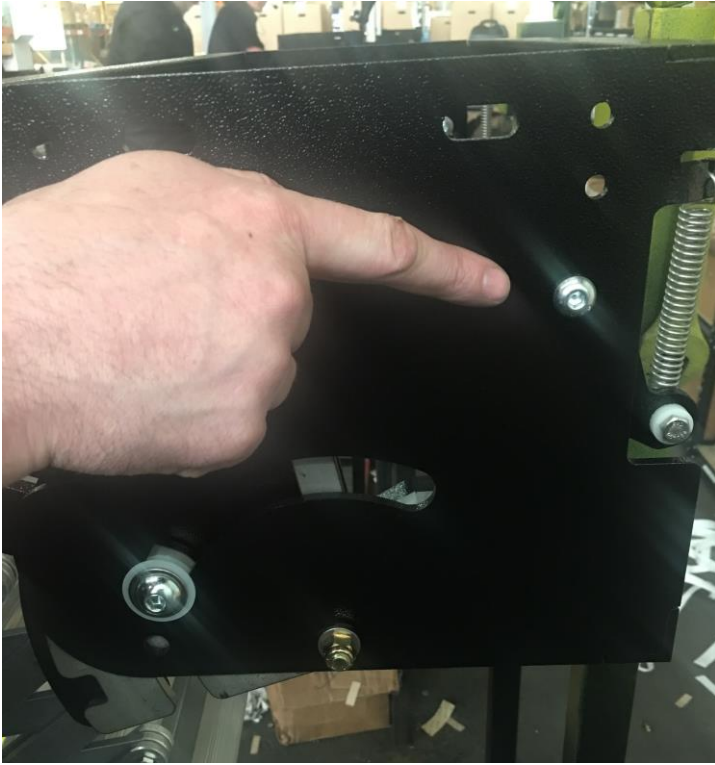

## **Step 9: Service Bulletin**

### **“Front to Back Step Cage Adjustment”**

When installing the GlowStep Revolution you will notice the hardware hole locations on the side of the step cage are slotted for 5/8" adjustability as seen in the photo below. All other steps (Not including the GlowStep Revolution) require the step to be pushed all the way back up against the trailers frame for additional support since the steps do not contact the ground. With the Earth to RV design of the GlowStep Revolution there is no need to install the step against the frame of the RV but rather pull it out towards the RV's side wall so it is flush with the outer face of the side of the RV. This is the proper installation location to provide adequate space for the safety release level pin.

Note- Pushing the GlowStep Revolution frame all the way back may cause the Safety pin to catch or drag along the RV's side wall potentially damaging the painted surface of the RV over time.

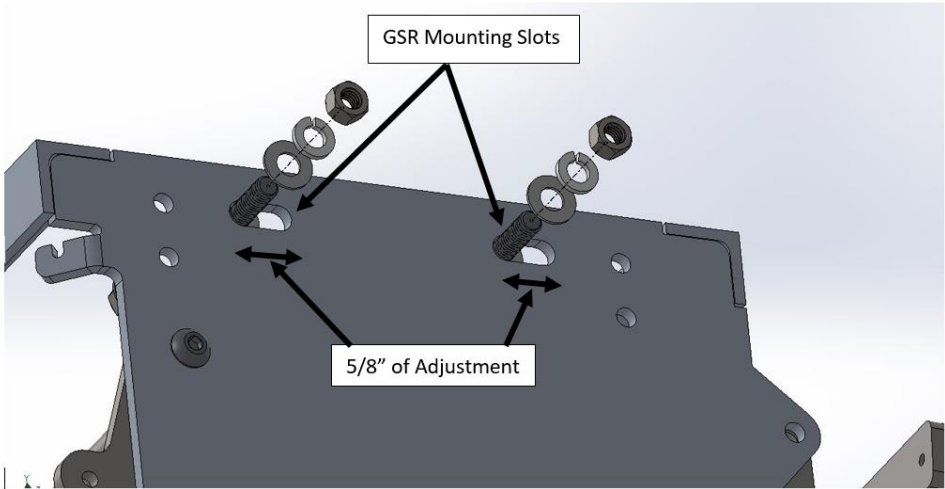

## **Step 10 (optional): GlowGuide Bracket Installation**

When installing a Torklift GlowGuide, the GlowGuide Bracket and GlowGuide Adapter will need to be installed as shown in figure 6.1. The GlowGuide Brackets can be installed on either All Terrain Landing Gear, depending on the side the GlowGuide is installed on. First, attach the GlowGuide Bracket to the GlowGuide Adapter. Next, attach the GlowGuide Adapter to the All Terrain Landing Gear. If these parts are not included with your glow guide, please contact Torklift International Customer Support at (800) 246-8132.

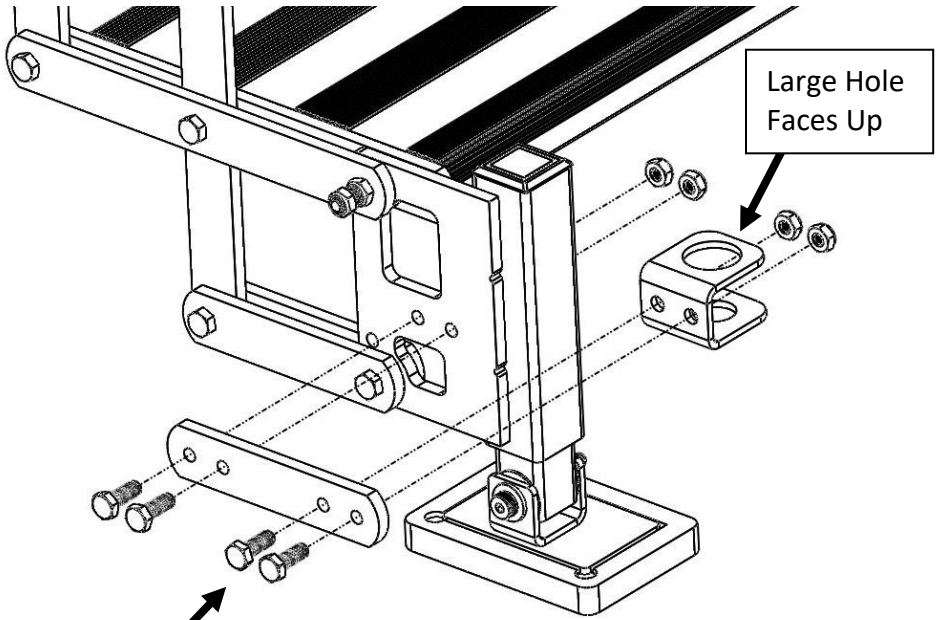

1/4"-20 x 3/4"  
SS Hex Bolts

**Figure 8.1**

1/4"-20 SS Thin  
Nylock Nuts

# Adding or Removing a Step

## Adding a Step

The allowable Glow Step Revolutions Sizes are 2 steps up to 6 steps.

To add a step to the Glow Step Revolution, you will need to purchase an Add-A-Step kit.

For A8002, A8003, A8004, or A8005 Glow Step Revolutions, order part number A8001

For A8102, A8103, A8104, or A8105 Glow Step Revolutions, order part number A8101

Instructions for adding the step will be included in the Add-A-Step kit.

## Removing a Step

Before beginning, refer to step 3B to remove the step assembly from the Glow Step Revolution.

### **Step A**

Disconnect the lower step from your Glow Step Revolution by removing the **1/4" x 1-1/6" SS Hex Bolts** as indicated in **Figure A.1**. Save the hardware as it will be used for reassembly. Be sure to keep track of the **1/4" Phenolic Thin Washers**, which are located between the **3 Hole Links**.

### **Step B**

Disconnect the lowest step still attached to the assembly. Disconnect the lower step from your Glow Step Revolution by removing the **1/4" x 1-1/6" SS Hex Bolts** as indicated in **Figure B.1**.

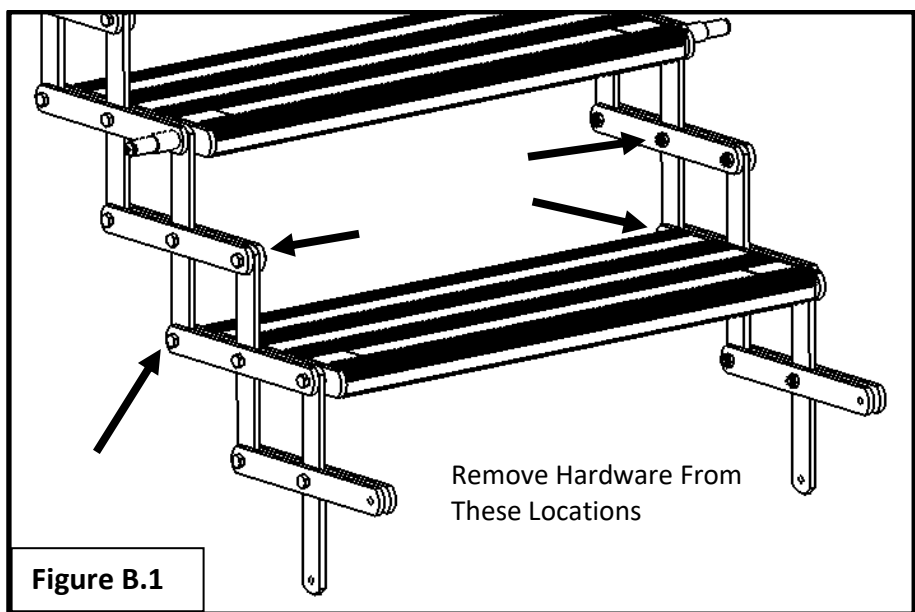
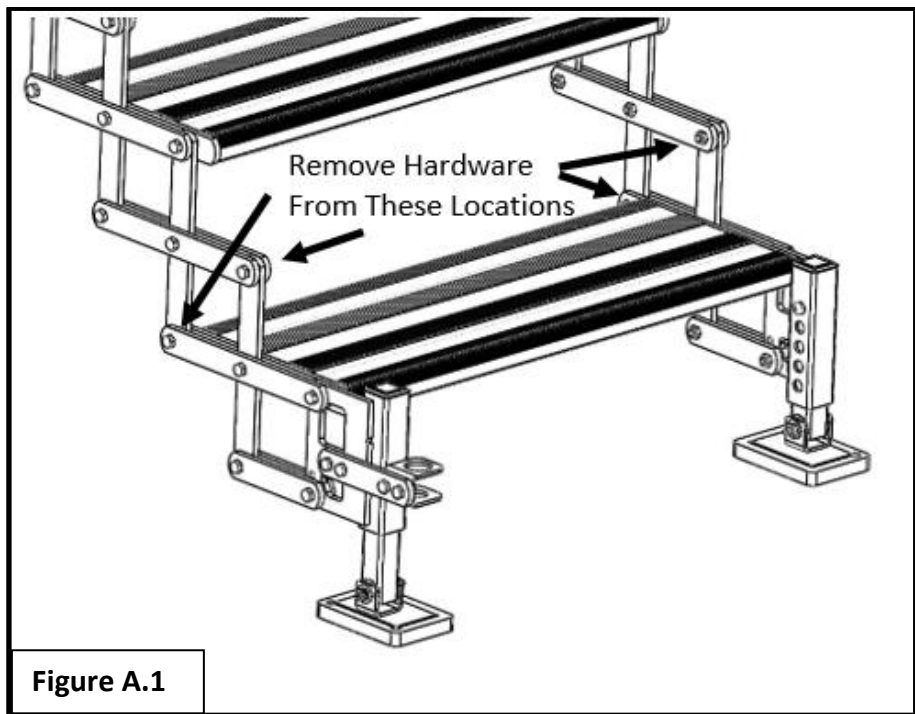

## Step C

- When reattaching the steps, it is helpful to rest the step assembly on its side. This will help to keep the washers from falling out of position.
- Reattach the bottom step (with all terrain landing gear) to the step assembly as shown in figure C.1.
- A small screw driver can be used to align the washers between the flat bar links before inserting the bolt.
- Repeat the hardware installation process for the remaining three holes.

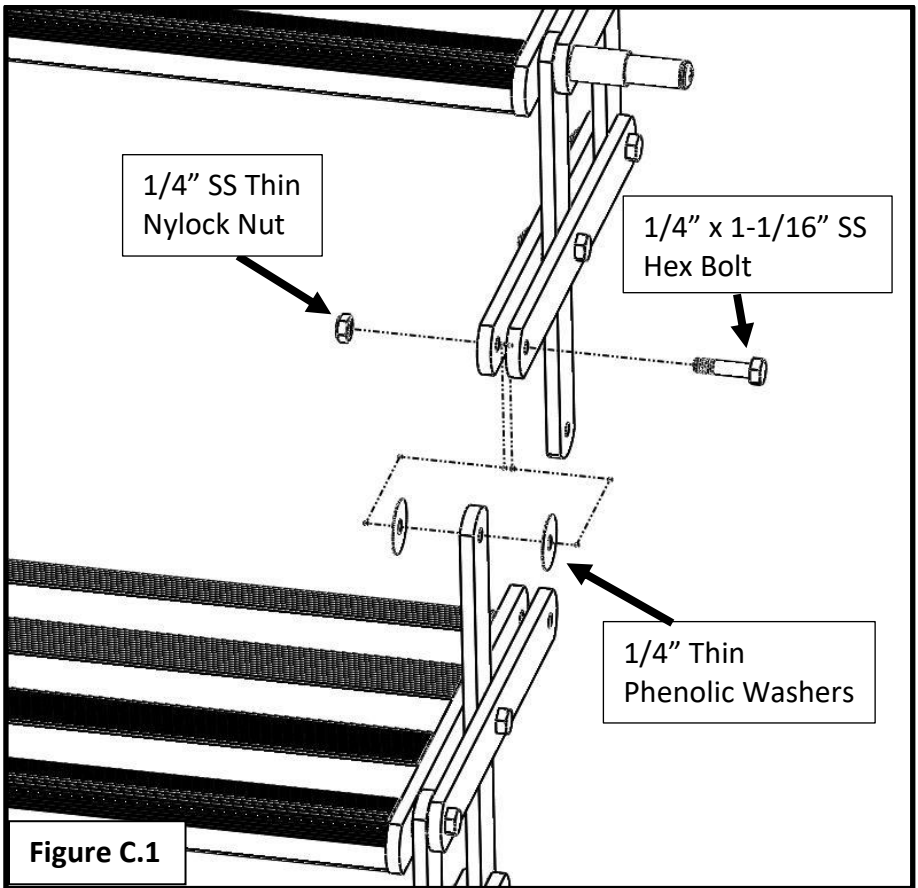

## Step D

If your step assembly now has three or more steps, skip to Step F

The nylon studs must always be placed on the second step from the top. When converting from a three-step to a two-step, the nylon studs must be relocated to the bottom step.

- Remove the nuts from the 1/4" x 3-1/2" Button Head Machine Screws. Using a screw driver, push the Screws out of their holes. The screw driver will hold the washers in place.
- Insert a 1/4" x 1-1/16" SS Hex Bolt back through the hole, pushing out the screw driver. Reattach the nuts. See figure D.1

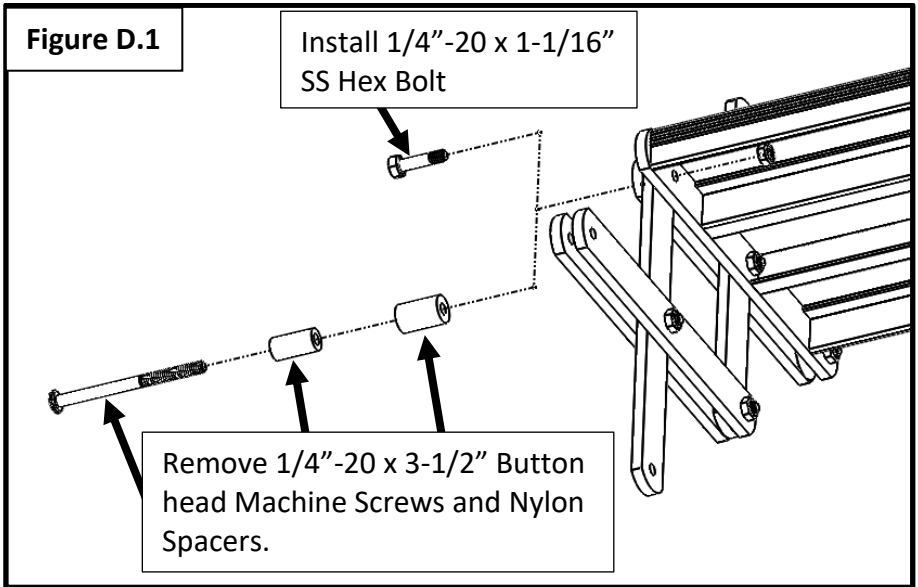

## Step D Cont.

- Remove the 1/4" Thin SS Nylock Hex Nuts on the two bolts holding the tops of the All-Terrain landing Gear to the step assembly.
- Use a screw driver to push the bolts out. The screw driver will hold the washers in place.
- Place a 1/4" x 3-1/2" Button Head Machine Screw through one small nylon spacer and one large nylon spacer.
- Insert the 1/4" x 3-1/2" Button Head Machine Screw into the step assembly, pushing the screw driver back out. Reattach the nuts. See Figure D.2

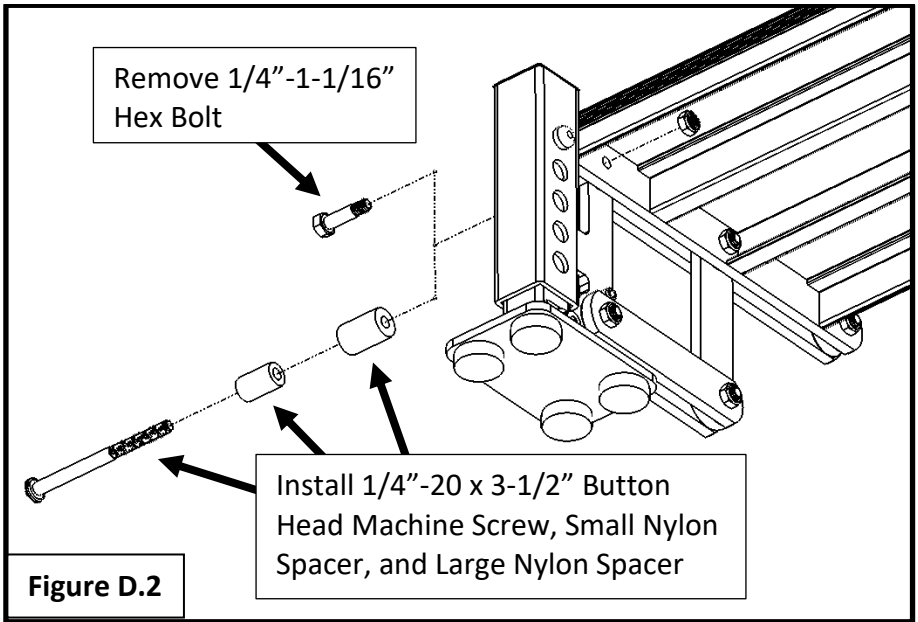



# Step F

For 4, 5-step assemblies, it will be necessary to reconfigure the shelf brackets. The shelf brackets can remain in their current positions for 2 and 3-step assemblies.

- 4-step assemblies will need to have the shelf brackets configured as shown in Figure F.1

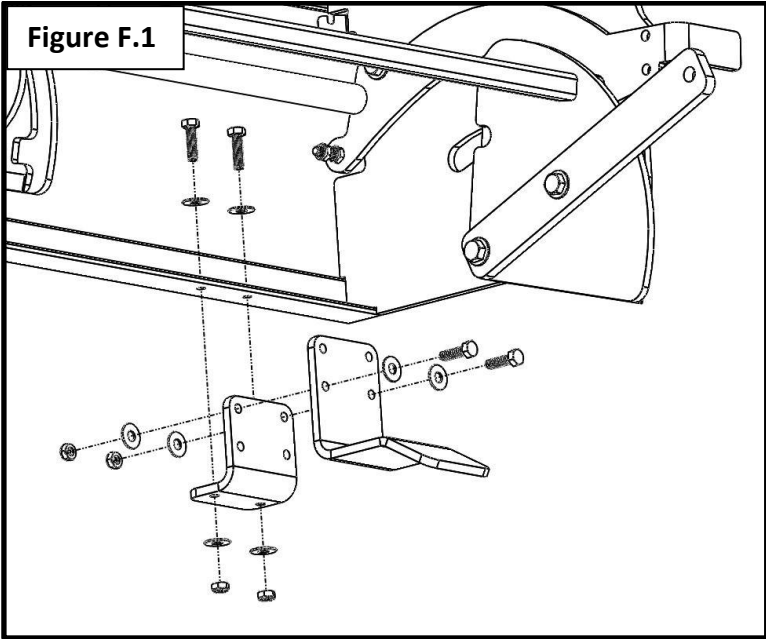

- 5-step assemblies will need to have the shelf brackets configured as shown in Figure F.2

# Step F Cont.

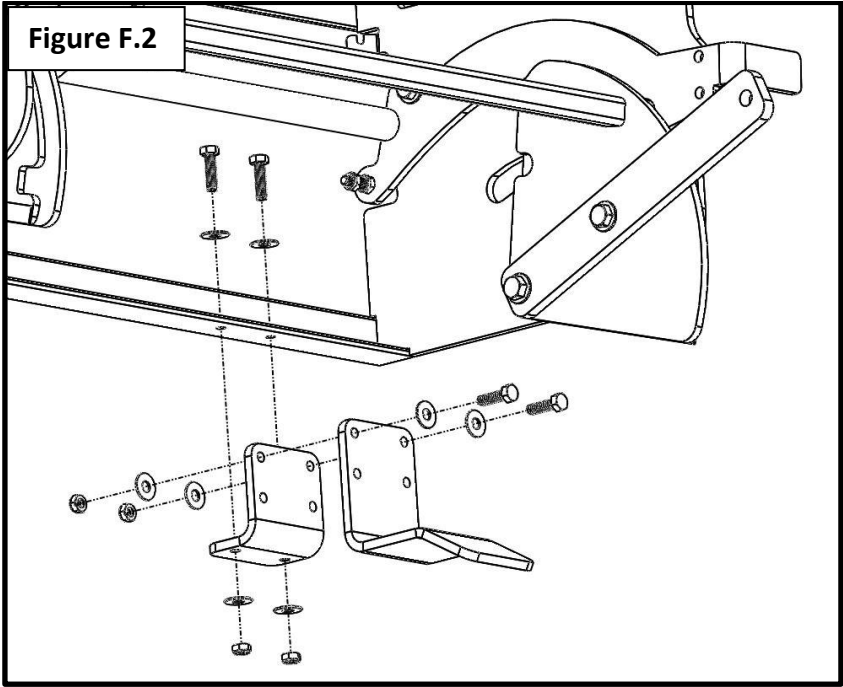

# Step G

The step is now ready to be installed. Proceed to Step 4 for installation.

# (optional Accessories):

GlowGuide handrail: **Part no. A7621**

GlowGuide locks: **Part no. A7509**

SafeStep pet safety barrier: **Part no. A7602**

Dirt Destroyer shoe cleaner: **Part no. A7603**



**GlowGuide**  
Multi use safety handrail



**SafeStep**  
Step riser safety panels



**All Terrain Landing Gear**  
Lower adjustment on either side to accommodate uneven terrain on bottom step



**Precision Elevation Control**  
3 positions of precision elevation control between the RV entry and the top step

**Three Levels of Upper Adjustment**



Position 1

Position 2

Position 3

Position 1

Position 2

Position 3

Position 4

Position 5

**Five Levels of Lower Adjustment**

**DirtDestroyer**  
Leave the dirt outside





**OVER 40 YEARS OF INNOVATION, QUALITY, SAFETY.**

## **Torklift International Limited Lifetime Warranty Information**

322 Railroad Ave N, Kent, WA 98032

Torklift will require proof of purchase to register, with pictures of any defective product before issuing a replacement. Torklift will not register any product without proof of purchase, which can be faxed, scanned, emailed, or mailed to the information provided below. Torklift warrants its hitches, custom hitch receivers, frame mounted tie downs, turnbuckles, and accessories (excluding wire harnesses which carry a 90 day warranty) from date of purchase against defects in material and workmanship under normal use and service for the ownership life of the original consumer purchaser. All plastic, rubber, and/ or electrical components maintain a warranty of up to one year from the date of the purchase. **ALL COMMERCIAL APPLICATIONS ARE WARRANTED FOR A PERIOD OF 90 DAYS FROM THE DATE OF INSTALLATION/SERVICE.** Torklift will replace **FREE OF CHARGE** any part which proves defective in material or workmanship when presented to Torklift, **TRANSPORTATION CHARGES PREPAID** by purchaser, at the address above. **THIS WARRANTY IS LIMITED TO DEFECTIVE PARTS REPLACEMENT ONLY. LABOR CHARGES AND/OR DAMAGE INCURRED IN INSTALLATION OR REPLACEMENT, AS WELL AS INCIDENTAL AND CONSEQUENTIAL DAMAGES CONNECTED THEREWITH ARE EXCLUDED.** This warranty does not include the finish or paint on our products. Rusting, cracking or peeling of the finish is also excluded. Some states do not allow the exclusion or limitation of incidental or consequential damages, so the above limitation or exclusion may not apply to you. Any damage to Torklift products as a result of misuse, abuse, neglect, accident, improper installation or any use violative of instructions furnished by Torklift or **WHEN USED IN ANY COMMERCIAL APPLICATION WILL VOID THE WARRANTY.** This warranty gives you specific legal rights, and you may also have rights which vary from state to state. With warranty service, you may be able to go to a small claims court, a state court or a federal district court.

**322 Railroad Ave N, Kent, WA 98032**

**Phone (800) 246-8132 Fax (253) 854-8003**

**Or visit our website: [www.Torklift.com](http://www.Torklift.com)**

Dear Valued Customer,

Thank you for making Torklift your choice for truck, camper packages and accessories for your vehicle. By choosing Torklift products, you have chosen a company that has been serving the RV industry for nearly 40 years and whose name has become synonymous with strength, quality and advanced design and installation.

Please take a few moments of your time to complete the Product Registration Warranty Card on the next page. When registering your newly purchased Torklift products, you can be assured that your contact information is secure and that you and your product are getting the attention and respect that you deserve.

Thank you again for choosing Torklift quality products.

**Register for your lifetime warranty and receive a free  
Torklift International gift.**

To Fax: Send copies of the questionnaire, warranty card and receipt to  
253-854-8003

To E-mail: Send copies of the questionnaire, warranty card and receipt to  
[warranty@torklift.com](mailto:warranty@torklift.com)

To Mail: Send to Torklift International 322 Railroad Ave N, Kent, WA 98032



## OFFICIAL WARRANTY REGISTRATION CARD

PLEASE FILL OUT THIS FORM COMPLETELY AND RETURN TO TORKLIFT WITHIN

30 DAYS OF PURCHASE ACCOMPANIED BY A COPY OF YOUR ORIGINAL RECEIPT

### 1. PART(S) PURCHASED

TODAY'S DATE: \_\_\_\_\_

PART#: \_\_\_\_\_ PART#: \_\_\_\_\_

PART#: \_\_\_\_\_ PART#: \_\_\_\_\_

PART#: \_\_\_\_\_ PART#: \_\_\_\_\_

### 2. PURCHASER INFORMATION

NAME: \_\_\_\_\_

ADDRESS: \_\_\_\_\_

CITY: \_\_\_\_\_ STATE: \_\_\_\_\_ ZIP / POSTAL CODE: \_\_\_\_\_

PHONE: (\_\_\_\_) \_\_\_\_\_ - \_\_\_\_\_ EMAIL: \_\_\_\_\_

### 3. TRUCK INFORMATION

YEAR: \_\_\_\_\_ MAKE: \_\_\_\_\_

MODEL: \_\_\_\_\_ BED LENGTH: \_\_\_\_\_

### 4. CAMPER INFORMATION

YEAR: \_\_\_\_\_ MAKE: \_\_\_\_\_ MODEL: \_\_\_\_\_

### 5. DEALER INFORMATION

PURCHASED FROM: \_\_\_\_\_

ADDRESS: \_\_\_\_\_

CITY: \_\_\_\_\_ STATE: \_\_\_\_\_ ZIP / POSTAL: \_\_\_\_\_

INSTALLED BY: \_\_\_\_\_ OWNER ABOVE DEALER ANOTHER DEALER

IF ANOTHER DEALER, WHO: \_\_\_\_\_