

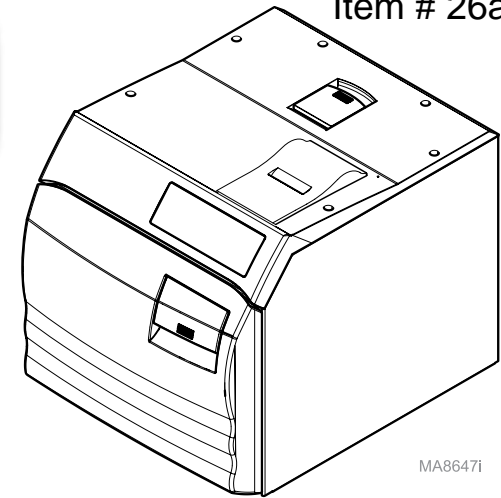



Specifications: M9 / M9D (-020 thru -022)
M11 / M11D (-020 thru -022)

Item # 26a



MA86471

WARNING

 For 115 VAC models: Use 104 - 127 VAC, 50/60 Hz alternating current only.
 For 230 VAC models: Use 207 - 253 VAC, 50/60 Hz alternating current only.
 Failure to do so may result in electric shock to personnel and / or damage to sterilizer.

Equipment Alert

 A separate (dedicated) circuit is required for this sterilizer. Sterilizer should not be connected into an electrical circuit with other appliances or equipment unless circuit is rated for the additional load.

For model-specific ratings / dimensions, refer to the appropriate page.

Model Numbers	Refer to:
M9 / M9D (-020 / -022)	Page 2
M11 / M11D (-020 / -022)	Page 3

Electrical Requirements: M9 / M9D / M11 /M11D (-020 / -022)	
Note To be properly grounded, unit must be connected to a matching, grounded, dedicated, properly polarized receptacle.	
115 VAC Unit:	115 VAC, (+/- 10%) 50/60 Hz, 12 amp Dedicated Supply Circuit*: 120 VAC, 50/60 Hz, 15 amp Max. Power Consumption: 1425 Watts
230 VAC Unit:	230 VAC, (+/- 10%) 50/60 Hz, 6.5 amp Dedicated Supply Circuit*: 230 VAC, 50/60 Hz, 10 amp Max. Power Consumption: 1500 Watts
* Power source must have over-voltage limits less than 1500 watts from mains to ground. (Installation Category II in accordance to IEC664)	
Fuse Ratings:	
115 VAC	F1.....0.25 Amp, 250V, 3 AG Slo-blo, 1/4" x 1 1/4"
	F2.....15 Amp, 250V, 3 AB Fast Acting, 1/4" x 1 1/4"
230 VAC	F1.....0.125 Amp, 250V, Medium-Time Lag, 5 x 20 mm
	F2.....8 Amp, Type F 250V, Fast Acting, 5 x 20 mm

Specifications / Dimensions:

Specifications Chart: M11 / M11D (-020 / -022)	
Physical Dimensions:	
Overall Length w/Plug	23.8 in. (60.5 cm)
Overall Width	17.8 in. (45.2 cm)
Overall Height w/Printer	17.8 in. (45.2 cm)
Counter Area	17.8. x 21 in. (45.2 cm x 53.3 cm)
Chamber	11 in. dia. x 18 in. deep (28 cm x 46 cm)
Standard Tray, Large	9 in. x 15 in. x 1 1/8 in. (22.9 cm x 38 cm x 2.9 cm)
Standard Tray, Small	6 5/8 in. x 15 in. x 1 1/8 in. (14.3 cm x 38 cm x 2.9 cm)
Weights:	
Weight with Empty Reservoir	99 lbs. (44.9 kg)
Weight with Shipping Carton	131 lbs (59.4 kg)
Water Reservoir Capacity	1.4 Gallons (5.3 liters) to Full Mark usable volume is 1.0 gallons (3.8 liters)
Water Usage (per cycle)	
Standard Configuration	120 to 180 ml (varies depending on the cycle)
Connected to Direct -to-Drain Thermal Reduction system. (VistaCool™)	650 ml
Chamber Pressure at 270 °F (132 °C)	27.1 psi. (186.2 kPa)
Safety Valve Setting	40 psi (275.8 kPa)
Heat Emission	5000 BTU / hr during operation
Certifications	ASME Boiler & Pressure Vessel Code, Section VIII, Division 1. Canadian Registration Number available
	UL61010-1 / IEC 61010-2-040 / CAN/CSA C22.2, #61010-1 / CSA C22.2, #61010-2-040- 07 Part 2-040

