



INSTRUCTION MANUAL



STAINLESS STEEL TABLES

USAGE AND MAINTENANCE



Read and understand all of the instructions and safety information in this manual before operating this product.

Table of Contents

STANDARD FEATURES - INSTRUMENT TABLES	3
Optional Features of Instrument Tables:.....	3
Model Numbers and Overall Dimensions.....	3
STANDARD FEATURES - UTILITY TABLES	4
Optional Features of Utility Tables:.....	4
Model Numbers and Overall Dimensions.....	4
STANDARD FEATURES - NESTED TABLES	5
Optional Features of Nested Tables:.....	5
Model Numbers and Overall Dimensions.....	5
STANDARD FEATURES - ADJUSTABLE OVER OPERATING TABLES	6
Optional Features of Adjustable Over Operating Tables:.....	6
Model Numbers and Overall Dimensions.....	6
STANDARD FEATURES - CENTRAL SUPPLY TABLES	7
Optional Features of Central Supply Tables:.....	7
Model Numbers and Overall Dimensions.....	7
UNPACKING INSTRUCTIONS	8
ADJUSTABLE OVER OPERATING TABLE - Adjusting Maximum/Minimum Heights (all models)	10
Casters and Wheels - Care and Maintenance	11
Replacement Parts - General	12
Instructions for Cleaning Stainless Steel Tables	13
Limited Lifetime Warranty	14

DESCRIPTION OF PRODUCT

This manual covers the following MAC Medical stainless steel tables - Instrument Tables/ Utility Tables/ Nested Tables/ Central Supply Tables/ Adjustable Over Operating Tables.

PURPOSE OF THIS MANUAL

This manual covers the specifications, operation and maintenance of MAC Medical stainless steel tables.

KEEP THIS MANUAL

STANDARD FEATURES - INSTRUMENT TABLES

Instrument Tables come Standard with:

- Fully welded construction
- Reinforced tops
- Stainless steel legs (1 1/4" 16 gauge)
- Stainless steel top (16 gauge type 300 series)
- Stainless steel under shelf (18 gauge type 300 series)
- 2" Swivel Casters

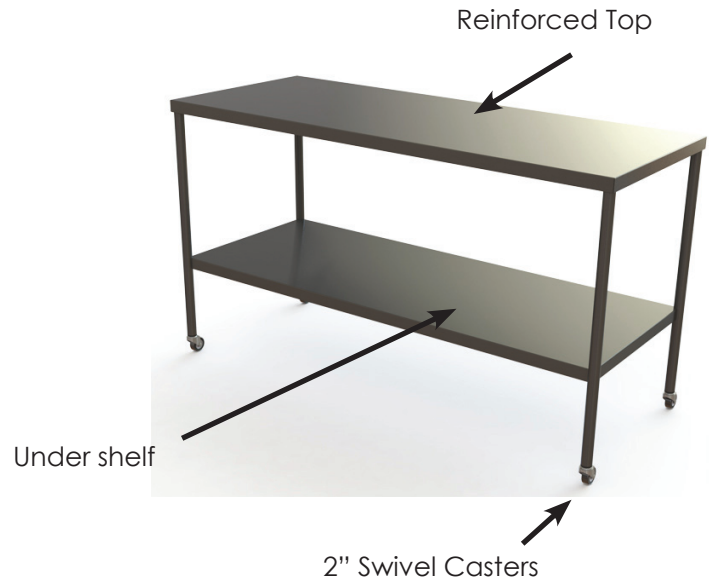

Optional Features of Instrument Tables:

- 3" Swivel Casters
- Locking Casters
- Drawers under all sides
- Guard Rails on 3 sides (available on top or bottom shelf)
- H or U Braces instead of under shelf
- Side Extensions
- 1" Lip on back
- Multiple under shelves

Model Numbers and Overall Dimensions

Model Number	Overall Dimensions
T0001	20"D x 16"W x 34"H
T0002	30"D x 16"W x 34"H
T0003	36"D x 24"W x 34"H
T0004	48"D x 24"W x 34"H
T0005	60"D x 24"W x 34"H
T0006	72"D x 24"W x 34"H
T0049	48"D x 20"W x 34"H
T0053	30"D x 28"W x 34"H
T0054	72"D x 30"W x 34"H
T0058	36"D x 20"W x 34"H
T0059	60"D x 30"W x 34"H
T0088	33"D x 18"W x 34"H
T0101	36"D x 30"W x 36"H
T0115	20"D x 20"W x 34"H

STANDARD FEATURES - UTILITY TABLES

Utility Tables come Standard with:

- Fully welded construction
- 1 under shelf
- Top guard rail (on 3 sides)
- 3" Casters (2 Swivel and 2 Locking)



Optional Features of Utility Tables:

- Multiple under shelves
- No guard rail

Model Numbers and Overall Dimensions

Model Number	Overall Dimensions	Drawers
T0086	20"D x 16"W x 34"H	1
T0077	20"D x 16"W x 34"H	2
T0096	20"D x 16"W x 34"H	3
T0097	20"D x 16"W x 34"H	4
T0902-3318-1D-GR	33"D x 18"W x 34"H	1
T0902-3318-2D-GR	33"D x 18"W x 34"H	2
T0902-3318-3D-GR	33"D x 18"W x 34"H	3

STANDARD FEATURES - NESTED TABLES

Nested Tables come Standard with:

- Fully welded construction
- Stainless steel legs (1 1/4" 16 gauge)
- Stainless steel tops (16 gauge type 304)
- Stainless steel U Brace (1 1/4" 16 gauge)
- 2" Swivel Casters

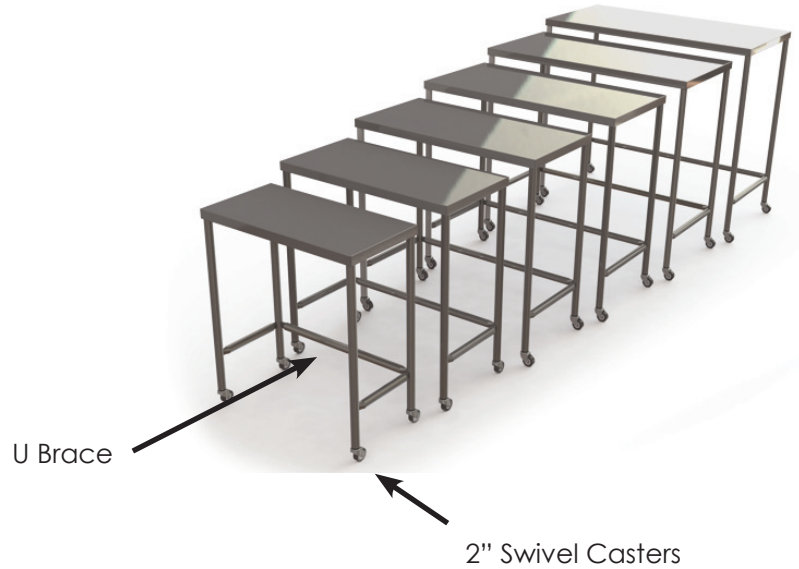

Optional Features of Nested Tables:

- No Optional Features are offered for this model.

Model Numbers and Overall Dimensions

Model Number	Overall Dimensions
T0089	Set of 6 (T0090 thru T0095)
T0090	48"D x 24"W x 42"H
T0091	44"D x 22"W x 40"H
T0092	40"D x 20"W x 38"H
T0093	36"D x 18"W x 36"H
T0094	32"D x 16"W x 34"H
T0095	28"D x 14"W x 32"H

STANDARD FEATURES - ADJUSTABLE OVER OPERATING TABLES

Adjustable Over Operating Tables come Standard with:

- Ergonomically friendly Manual Height Adjust (height range: 36.5" - 48.25")
- 3" Casters (2 Swivel and 2 Locking)

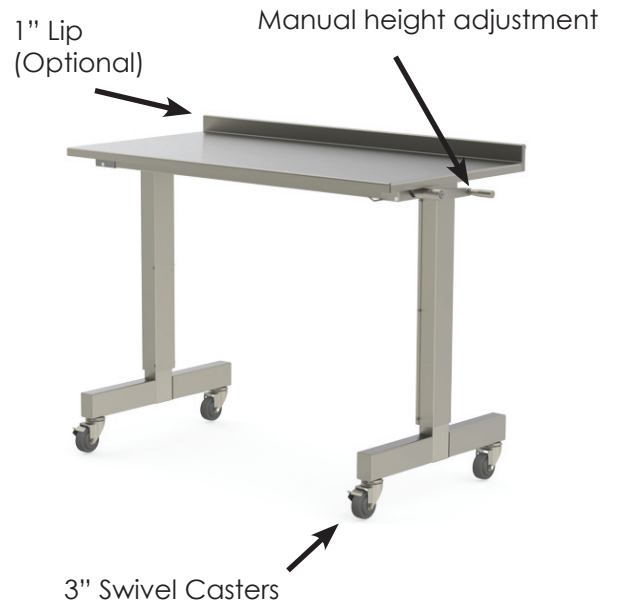

Optional Features of Adjustable Over Operating Tables:

- 1" Lip on back

Model Numbers and Overall Dimensions

Model Number	Overall Dimensions (Height at Lowest Setting)
T0082-3442	42"D x 34"W x 36.5"H
T0082-4824	24"D x 48"W x 36.5"H
T0082-6024	24"D x 60"W x 36.5"H

STANDARD FEATURES - CENTRAL SUPPLY TABLES

Central Supply Tables come Standard with:

- Heavy duty, Stainless steel construction
- Sterile frame
- 2" square legs
- One under shelf
- 4" Casters (2 Swivel and 2 Locking)

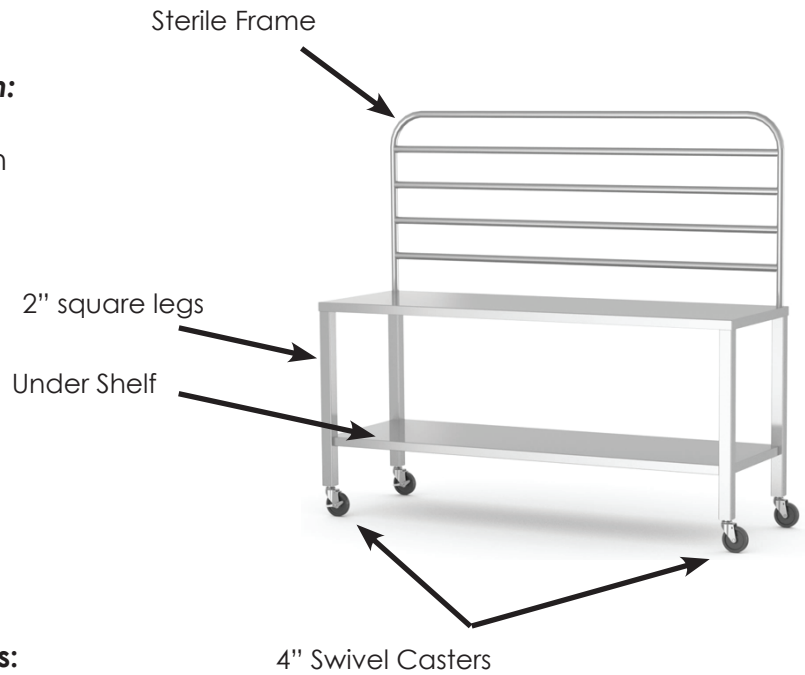

Optional Features of Central Supply Tables:

- 6" plastic bin
- 10" plastic bin
- Drawer

Model Numbers and Overall Dimensions

Model Number	Overall Dimensions
CST3260-SWF	32"D x 60"W x 34"H
CST2472-SWF	24"D x 72"W x 34"H
CST3684-SWF	36"D x 84"W x 34"H

Stainless steel tables may be ordered with drawers with optional 4" Pull Handles made of CuVerro® Bactericidal Copper.



- This product is made from a copper surface that continuously kills bacteria* left behind by dirty hands, killing more than 99.9% of bacteria* within 2 hours.

Laboratory testing has shown that when cleaned regularly this surface:

- Kills more than 99.9% of bacteria* within 2 hours, and continues to kill 99% of bacteria* even after repeated contamination.
- Delivers continuous and ongoing antibacterial* action, remaining effective in killing greater than 99.9% of bacteria* within 2 hours.
- Helps inhibit buildup and growth of bacteria* within 2 hours of exposure between routine cleaning and sanitizing steps.
- Kills greater than 99.9% of Gram-negative and Gram-positive bacteria* within 2 hours of exposure.
- Continuously reduces bacterial* contamination, achieving 99.9% reduction within 2 hours of exposure.

* Laboratory testing shows that, when cleaned regularly, CuVerro surfaces kill greater than 99.9% of the following bacteria within 2 hours of exposure: Methicillin-Resistant *Staphylococcus aureus*, *Staphylococcus aureus*, *Enterobacter aerogenes*, *Pseudomonas aeruginosa*, *E. coli* O157:H7, and Vancomycin-Resistant *Enterococcus faecalis* (VRE).

The use of CuVerro® bactericidal copper products is a supplement to and not a substitute for standard infection control practices; users must continue to follow all current infection control practices, including those practices related to cleaning and disinfection of environmental surfaces. This surface has been shown to reduce microbial contamination, but it does not necessarily prevent cross contamination.

CuVerro® is a registered trademark of GBC Metals, LLC and is used with permission.

EPA Company No. 92702-IL-1

EPA Registration No. 92701

UNPACKING INSTRUCTIONS

Inspection

1. Receiving area must meet all State and Local regulations prior to unpacking.
2. Customer must inspect skid and Table both before and after unpacking to determine if any items were damaged during shipping.
3. All damaged items must be listed on the Bill of Lading.
4. Customer is responsible for the proper disposal of all packing materials. The disposal of these items must meet all State and Local regulations.

Unpacking the Stainless Steel Table

Stainless steel tables are shipped on well-constructed wooden skids. Two steel bands secure the Table to the skid. The stainless steel surfaces of the part are protected by heavy cardboard end-caps, and by layers of plastic wrapping.

Care must be taken while unpacking the stainless steel table to avoid damage. Do not drop tools on the table or scratch the surfaces with sharp edges. **IMPORTANT:** Wear gloves and eyewear during the unpacking operation.

Retain all shipping materials until the table is completely unpacked and inspected for damage.

1. Use tin snips to cut the metal bands holding the box to the wooden skid (Fig1).
2. Remove metal staples holding one end of the packing carton together.
3. Slide out table from side of packing carton with two attached cardboard end caps (Fig 2).
4. Remove 2 cardboard end caps.
5. Remove the plastic protecting wrapping.



Caution! Do not use a box cutter or any other cutting utensil to remove the plastic wrapping around the table. These items can scratch the protective coating on the stainless steel allowing the surface to rust.



Fig. 1: Boxed table on skid



Fig. 2: Wrapped table with end caps

- Note:** Some tables will ship with their casters uninstalled. They will be packed with the table in their own container (Fig. 3). These casters can be removed from their shipping box and simply inserted into holes at the base of the table legs. No other assembly is required.



Fig. 3: Wrapped Casters

- The stainless steel table is now ready for use.
- Discard shipping and packing materials in compliance with State and Local regulations.
- When not in use, tables must not be double stacked while in storage. While still in their shipping cartons, tables must not be double stacked when not in use.

ADJUSTABLE OVER OPERATING TABLE - Adjusting Maximum/Minimum Heights (all models)

Manual Hydraulic Pump with Handcrank

The Adjustable Over Operating Table is equipped with a manual hydraulic pump with handcrank (Fig. 4-5). The handcrank can be folded to disappear under the table (Fig. 6).

1. Crank table to the desired height.
2. Pull the crank outwards, then rotate downward through the table side panel slot to fold the handle under the table.

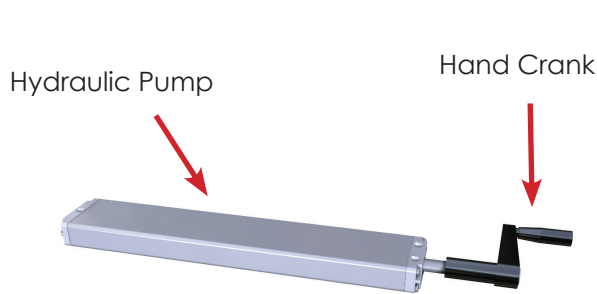

Fig. 4: Hydraulic pump with handle

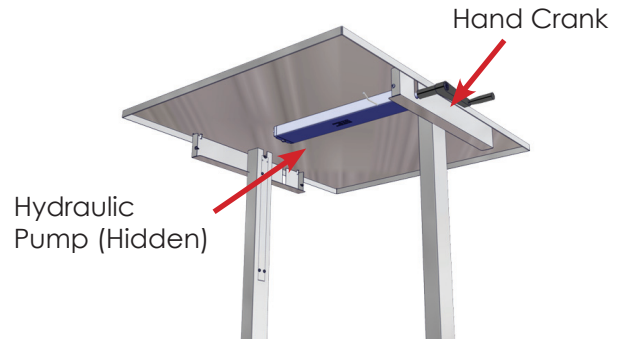

Fig 5: Hydraulic pump location



Fig. 6: Handle extended and folded under

The minimum height of the Adjustable Over Operating Table height tables is 36.5".

The maximum extended height of the Adjustable Over Operating Table is 48.25" (fig. 7)

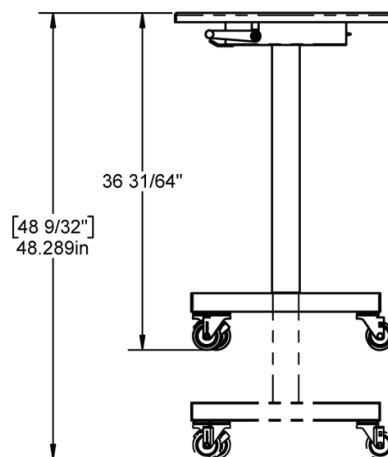

Fig. 7: Min/Max table height

Casters and Wheels - Care and Maintenance

Users of the Stainless steel tables are responsible for the proper care, use and maintenance of the equipment. The tables can become damaged and unsafe if used improperly.

- Never overload the tables.
- Do not drop heavy loads on the tables
- Do not move the tables at high speeds.

Using the tables in any of the above conditions can result in failure of the Casters, Wheels or other parts of the equipment.

Periodically inspect the bottom of the tables and look for any of the following issues –

- Broken welds
- Loose nuts or bolts. These should be tightened.
- Frame Distortion. This could be caused by an overloaded table, or by impacts with other objects while the table was being moved.

Casters:

- Make sure the Casters are in good condition. For Swivel Casters, if the caster has excessive play due to wear, it may need replacement. If it does not turn freely, corrosion or dirt may also make it necessary to replace them.

Wheels:

- Wheels should be checked for visible tread wear. Flat spots due to accumulation of material, such as string or thread, can cause the wheel to bind.
- Rubber tires can be badly worn which can make it hard to steer the cart and can damage the floor. Replacement wheels and casters should be kept on hand to keep equipment in working order.

Replacement Parts - General

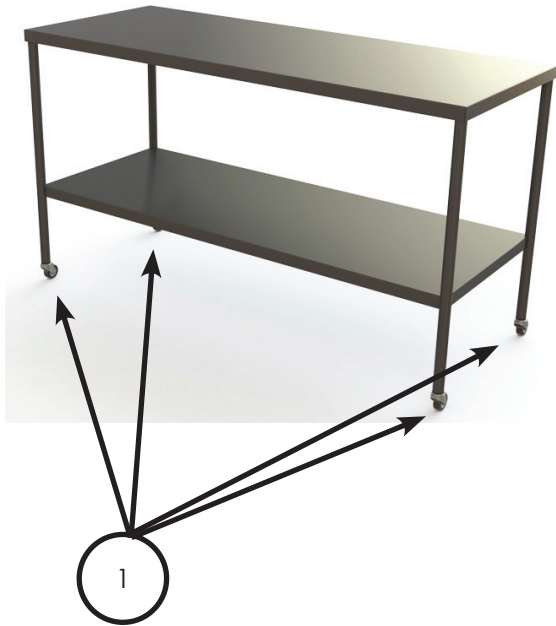



Item ID	Part Number	Description	QTY.	Models
1	T0009	2" Swivel Caster	4	All Instrument Tables All Nested Tables
1	T0078	3" Swivel Caster	4	All Instrument Tables All Utility Tables All Adjustable Over Operating Tables
1	T0078-B	3"Swivel Caster w/ Brake	2	All Utility Tables All Adjustable Over Operating Tables
1	t0120	4" Swivel Caster	4	Central Supply Tables
1	H0166-B	4" Swivel Caster w/ Brake	2	All Central Supply Tables
2	H0090-07	Hydraulic Pump w/ Handle	1	All Adjustable Over Operating Tables

Instructions for Cleaning Stainless Steel Tables

Stainless Steel tables must be cleaned on a regular basis to prevent any unnecessary damage to the stainless steel surfaces.

When cleaning stainless steel tables, make sure to use the proper approved cleaning agents and cleaning materials.

 CAUTION DO NOT USE these Cleaning Materials	 CAUTION DO NOT USE these Cleaning Agents
Abrasive Pads	Hard Water (water with a pH reading above 7.0).
Scrapers	Hydrochloric Acid
Steel Wool	Steam or high pressure water
Wire Brushes	Bleach or any compounds containing chlorine or Sodium hypochlorate, or ammonium chloride salts.

Approved cleaning materials and agents

- Soft, clean lint-free cloth
- Non-abrasive cleaning pads
- Soft bristle brush
- Mild detergents
- Sodium Bicarbonate (baking soda)
- Distilled water (pH rating 7) alone or with a mild detergent
- White vinegar (in a spray bottle)
- Isopropyl Alcohol
- Hospital-grade non-bleach disinfectants
- Cleaners approved for use on stainless steel

Cleaning Stainless Steel Surfaces

1. Using a damp, lint-free cloth and approved cleaner, wipe down the entire exterior surface of the stainless steel table. Using a damp, lint-free cloth with distilled water and a mild detergent, wipe down the entire exterior surface of the stainless steel table.
2. Wipe the steel surface along the direction of its grain as shown below.

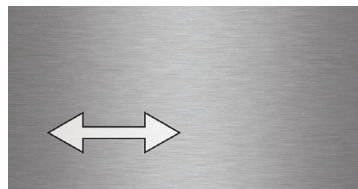

3. Let the cleaned table air dry.

Cleaning Decals or Printed Labels

- Use only distilled water and a mild detergent applied with a clean, dry lint-free cloth to clean decals or printed labels.
- Cleaning agents can remove or smear any printing from decals and print labels.
- Cleaning agents can damage plastic materials used in manufacturing covers for electronic items such as touch-screen pads.

Limited Lifetime Warranty

MAC Medical warrants to the original purchaser that its Proprietary Products will be free from defects in workmanship or materials under normal use and service for the life of the product, so long as owned by the original purchaser, according to the limitations set forth below.

Defective products shall be repaired or replaced at MAC Medical's option at no cost to the original purchaser provided:

1. The customer must obtain a written return authorization supplied by MAC Medical's customer service department. The product must be returned, properly packaged, with a copy of the original sales receipt and copy of the RMA authorization. Please call (877) 828-9975 or (618) 476-3550 to receive a return authorization.
2. The customer must pre-pay freight charges to and from MAC Medical and must ship merchandise properly packaged, in a way the product will not be damaged during transit to the factory. MAC Medical does not warranty any freight damage to or from the factory. It is the customer's responsibility to inspect the product for packaging damage before signing the BOL.

This warranty does not apply to products, which have been subject to abuse, misuse, accident, modification, alteration, tampering, negligence, lack of routine maintenance or misapplication; or products that have been repaired by other than MAC Medical or its authorized representatives.

This warranty does not apply to glass, fabrics, vinyl, seat coverings, cushions, padding or their stitching, gluing or installation. Component parts not manufactured by MAC Medical, such as casters, caster inserts, any components made from rubber or plastic, circuit boards, fan heaters, plumbing parts, electrical switches and other components are also excluded. For these component parts, MAC Medical will pass on the original manufacturer's warranty to MAC Medical equipment original purchasers. Please consult factory for questions regarding the warranties of these component parts. This warranty does not apply to custom fabricated products. Consult factory.

UNLESS EXPRESSLY SET FORTH IN THIS WARRANTY, THERE ARE NO OTHER WARRANTIES, WHETHER EXPRESS OR IMPLIED, OF FITNESS AND / OR MERCHANTABILITY OR ANY OTHER WARRANTY IMPLIED BY CUSTOM, USAGE OR COURSE OF DEALING.

Liability of MAC Medical under this warranty is limited to the repair and / or replacement of any products. MAC Medical specifically excludes and disclaims any responsibility for any incidental or consequential damages claimed to have arisen from any defect in workmanship or materials. No representative has any authority to change or enlarge the above warranty or MAC Medical liability. This document supersedes all previous warranty provisions.

To place an order, contact our customer service department at **618-476-3550** or **877-828-9975** or by email at **sales@macmedical.com**

Customer needs are our first priority.

MAC Medical, Inc.
Printed in USA
Publication No. MAN-050 REV B
February 2019

Information regarding this product is subject to change without prior notice.



Corporate Office
325 West Main Street
Belleville, IL 62220

Manufacturing Plant
820 South Mulberry Street
Millstadt, IL 62260

Phone: 618-476-3550 • Toll Free: 877-828-9975 • www.macmedical.com