

Greenbox Liquid Tank Containers

GTX-20

Product Information

- Provides safe and convenient storage
- Transports via ship, rail, and road
- ISO stackable frame up to 8 high
- Highly customizable loading and unloading process
- Bottom or top discharge
- Walkable roof with access ladder
- GTX-20 Model is exclusively designed to carry dangerous and / or explosive materials.
- American Bureau of Shipping, Association of American Railroads*, and Transports Internationaux Routiers approved.

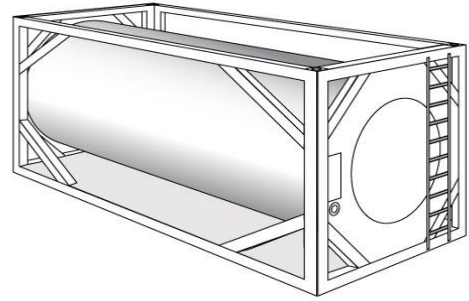

[Standard Model GTX-20]

Capacity	14000 - 26000 liters	3700 – 6868 gallons
Tare	3800 KG	8378 lbs.
Usage	Chemical & Food grade liquids	
Max. weight	36000 KG	79366 lbs.
Size	20ft	
Compartments	1 / Vacuum tank	
Heating system	Steam Heating	
Cladding type	1.8 mm GRP	
Steel thickness	4.4 mm	
Test pressure	6.0 Bar	
Work pressure	4.0 Bar	
Airline	1,5" BSP Airline Ball Valve	
Insulation	50 mm Glass wool	
Discharge type	Bottom / Top	
Material	Stainless steel 316	
Certificate	ISO/IMO/CSC/ABS/TIR	

Disclaimer

1. All figures and calculations are based on the best information currently available.
2. Above information should be solely used as a reference as all Greenbox units are manufactured and designed to meet each customer's need.
3. Greenbox containers are material specific. Actual capacity and rating will vary greatly depending on the degree of customization with utilization of aerators and the angle of the hopper.
4. Application for AAR certification for Greenbox is currently pending.

