

PALMARY PRODUCTS

- Centerless Grinder
- Cylindrical Grinder
- Internal Grinder
- Vertical Grinder
- Surface Grinder
- Special Purpose Grinder

www.palmary.com

SURFACE GRINDER

PSG series

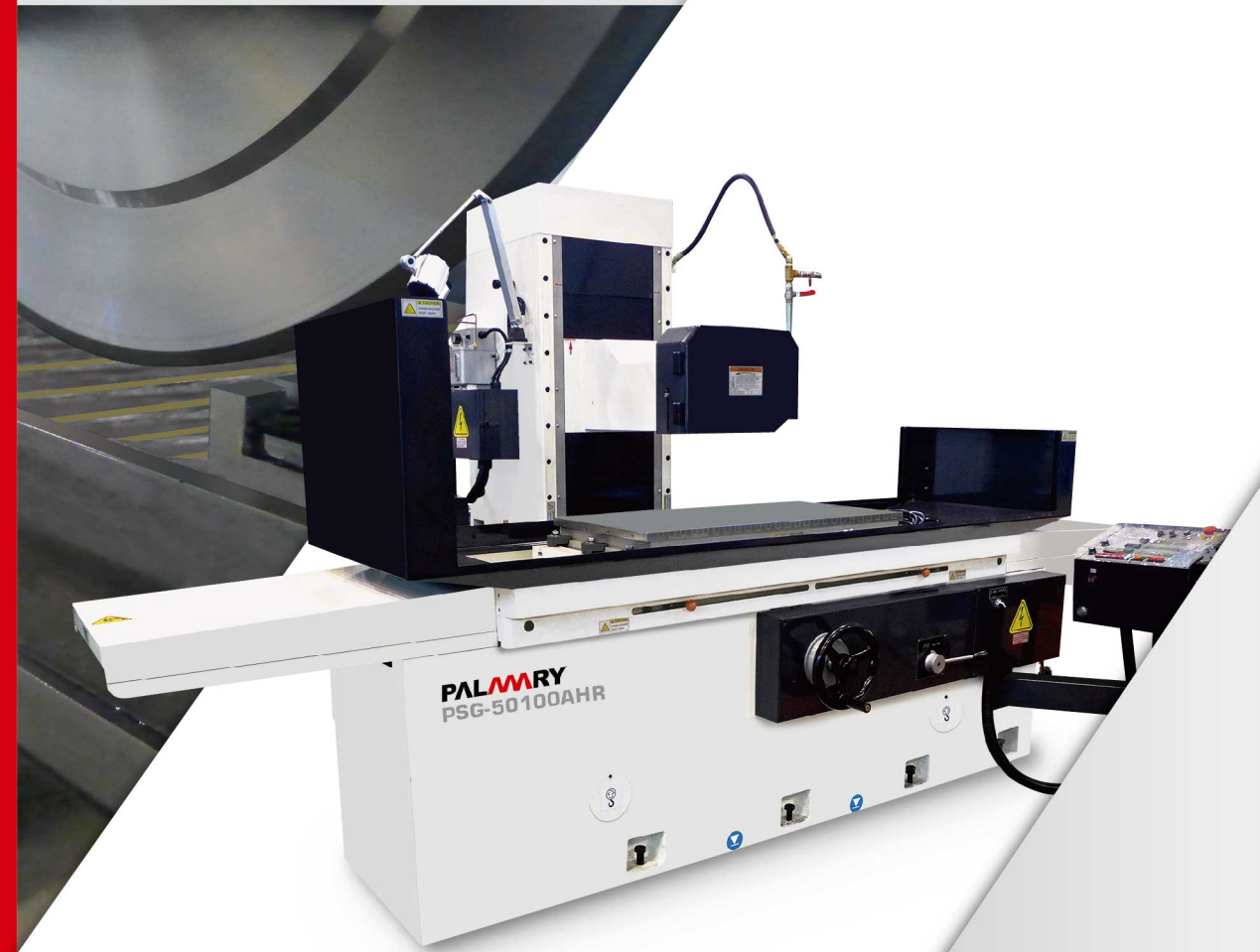

PALMARY



PALMARY MACHINERY CO., LTD.

No. 77, Gongye Rd., Dali Dist.
Taichung City 41280, Taiwan.
Tel: +886-4-2492-9799
Fax: +886-4-2492-9499
E-mail: palmary@grinding.com.tw
www.palmary.com



2204N3

PALMARY



THE QUALITY-PROVEN SURFACE GRINDER DESIGNED WITH ACCURACY AND PRODUCTIVITY IN MIND

PRECISION PERFORMANCE BUILT INTO EVERY FEATURE

1. Uses strong cast iron and excellent structural design which eliminates internal stress and ensures rigidity, stability and accuracy.
2. The "H" series cross and vertical slideways are coated with Turcite-B providing stable movement and durable accuracy.
3. Uses P4 precision angular contact bearing for the spindle to ensure accuracy within 2 μ . Also adopts a cartridge design which is completely sealed and lubricated for high durability and accuracy.
4. For "AH" series, can be installed with automatic downfeed AD5 (NC) which adds greater convenience for grinding operations (optional).
5. Models above the PSG-50 Series all main casting parts like the column, table, etc. have double-wall construction to ensure rigidity and stability during heavy grinding.
6. Designed and manufactured to meet the needs of high accuracy and fine surface finish.
7. A wide range of models to choose from: manual, hydraulic and servomotor operated.



[PSG-50100AHR]



[PSG-D4080AH]



[PSG-CL3060AH]

**PRECISION
PERFECTION
EXCELLENCE**

COMPUTERIZED AUTOMATIC DOWN FEED AD5 (NC FUNCTION) (optional)



**AUTOMATIC DOWNFEED AD5 (NC)
CONTROL PANEL (optional)**

SURFACE GRINDING PLUNGE GRINDING

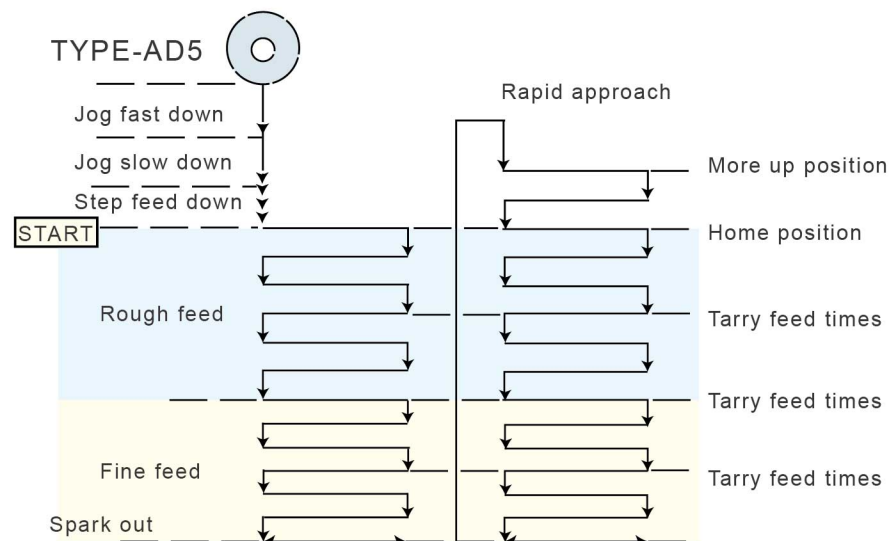

SURFACE GRINDING

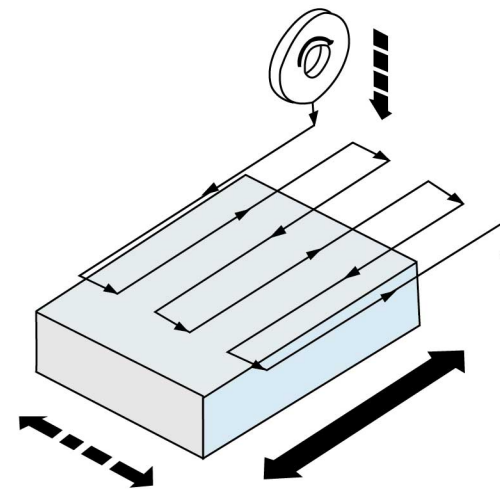

PLUNGE GRINDING

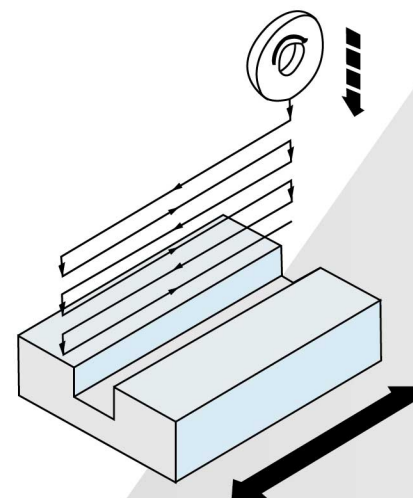

OPTIONAL ACCESSORIES

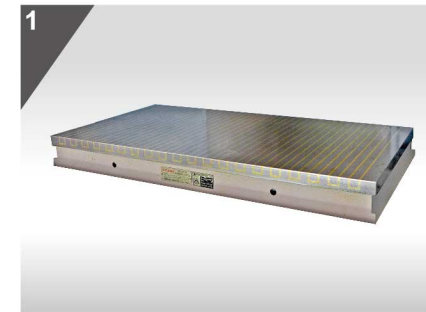

STANDARD ACCESSORIES

- Grinding wheel ---1
- Wheel flange ---1
- Flange extractor ---1
- Wheel balancing arbor ---1
- Wheel balancing stand ---1
- Wheel dresser with diamond ---1
- Leveling screw and plates ---1
- Work lamp (PSG-15/20/25/30/40 only) ---1
- Coolant system (PSG-50/60/70 only) ---1
- Tools and kits ---1

OPTIONAL ACCESSORIES

- Electro / permanent magnetic chuck
- Auto. demagnetizer for magnetic chuck
- Micro feed for vertical / corss feed (PSG-15/20/25/30/40 only)
- Parallel dresser
- Coolant system
- Dust suction with coolant system
- Dust suction system
- Magnetic coolant separator
- Paper filter
- Power rapid for vertical
- Automatic down feed AD5 (NC function)
- NC auto. dressing & compensation
- Back water splash guard

PSG

MODEL		PSG-1545H/AH PSG-2045H/AH	PSG-2550H PSG-2550AH
Working surface of table	(mm)	150 x 450 mm (6" x 18") (for C1545)	250 x 500 mm (10" x 20")
Max. surface ground	(mm)	200 x 450 mm (8" x 18") (for C2045)	
Max. distance center of spindle to table		450 mm (18")	500 mm (20")
Table speed		5~25 M/min.	
Table guideway		V & flat way	
Auto. cross feed increment	approx.	Manual (for H) 0.1 mm x 12 mm (for AH)	
Rapid power cross feed approx.	(mm/min.)	Manual (for H) 1100 (60 Hz) 900 (50 Hz) (for AH)	
Cross feed on hand wheel	1 rev 1 gra	5 mm (0.2") 0.02 mm (0.001")	
Rapid power head elevation approx. (option)	60 Hz 50 Hz	550 mm/min. (13"/min.) (60Hz) 450 mm/min. (11"/min.) (50Hz)	
Vertical feed on hand wheel	1 rev 1 gra	2 mm (0.05") 0.01 mm (0.0002") (standard) / 0.005 mm (0.0001") (with AD5)	
Vertical feed with M.P.G.	1 rev 1 gra	-	
Auto. down feed	(opt.)	0.001 mm~0.999 mm/Time (0.0001"~0.0999"/Time)	
Wheel speed	60 Hz / 50 Hz	3500 r.p.m. (60 Hz) / 2900 r.p.m. (50 Hz)	
Wheel dimension		180 x 13 x 31.75 mm (max. 200 x 20 x 31.75) (7" x 0.5" x 1.25") (max. 8" x 0.75" x 1.25")	
Spindle motor		2 HP	
Hydraulic pump motor		1 HP	
Auto. cross feed motor		25 W	1/5 HP
Rapid head elevation motor		1/5 HP (opt.)	
Coolant pump		1/8 HP (opt.)	
Sound pressure level		Below 78dB (A)	
Machine net weight		900 kg (1980 Lbs) 950 kg (2090 Lbs)	1350 kg (2970 Lbs)
Packing gross weight		1100 kg (2424 Lbs) 1150 kg (2530 Lbs)	1550 kg (3410 Lbs)
Machine floor space		2080 x 1200mm (1545 H/AH) 2100 x 1300 mm (2045 H/AH)	2340 x 1500 mm (89" x 55")
Packing dimensions (L x W x H)		2300 x 1460 x 1960 mm (91" x 58" x 77")	2300 x 1580 x 2200 mm (91" x 62" x 87")

• The mentioned specifications & dimensions are subject to change without notice.

M series

3 axes, manual.

H series

Longitudinal (hydraulic) and cross feed/vertical axes are manual.

AH series

Auto. cross feed, longitudinal (hydraulic) and vertical axis is manual.

PSG-D4080AH

1. Table longitudinal travel by sensor & solenoid valve.
2. Continuous lubrication is a standard accessory.

PSG-DL3060 / PSG-DS3060AH

1. Table longitudinal travel by sensor & solenoid valve.
2. Continuous lubrication is a standard accessory.
3. Auto crossing stroke adjustment.
3. Back water splash shield.

PSG-CS3060AH PSG-CL3060AH	PSG-DS3060AH PSG-DL3060AH	PSG-D4080AH	PSG-50100AHR PSG-60100AHR PSG-70100AHR	PSG-50150AHR PSG-60150AHR PSG-70150AHR	PSG-50200AHR PSG-60200AHR PSG-70200AHR
300 x 600 (12" x 24")		400 x 800 (16" x 32")	500 x 1000 (20" x 40") 600 x 1000 (24" x 40") 700 x 1000 (28" x 40")	500 x 1500 (20" x 60") 600 x 1500 (24" x 60") 700 x 1500 (28" x 60")	500 x 2000 (20" x 79") 600 x 2000 (24" x 79") 700 x 2000 (28" x 79")
500 mm (20")		550 mm (22")	600 mm (24")		
5~25 M/min. (200"~1000"/min.)					
V & flat way					
0.5 mm~20 mm (0.02"~0.8")					
1100 mm/min. (44"/min.) (60 Hz) 900 mm/min. (36"/min.) (50 Hz)					
5 mm (0.2") 0.02 mm (0.001")					
550 mm/min. (13"/min.) (60 Hz) 450 mm/min. (11"/min.) (50 Hz)			300 mm/min. (10"/min.)		
2 mm (0.05") 0.01 mm (0.0002")			-		
-			(x1) 0.1 mm (0.01") (x1) 0.001 mm (0.0001")	(x5) 0.5 mm (0.05") (x5) 0.005 mm (0.0005")	(x10) 1 mm (0.1") (x10) 0.01 mm (0.001")
0.001 mm~0.999 mm/Time (0.0001"~0.0999"/Time) (opt.)					
S: 3500 r.p.m. (60 Hz) / 2900 r.p.m. (50 Hz) L : 1750 r.p.m. (60Hz) / 1450 R.P.M. (50Hz)			1750 r.p.m. (60 Hz) / 1450 r.p.m. (50 Hz)		
S: 180 x 13 x 31.75 mm (7" x 0.5" x 1.25") L: 355 x 38 x 127 mm (14" x 1.5" x 5")		405 x 50 x 127 mm (16" x 2" x 5")	405 x 50 x 127 mm (16" x 2" x 5")		
2 HP (S type) / 5 HP (L type)		5 HP	10 HP / 15 HP (opt.)		
1 HP		2 HP	3 HP	5 HP	
			1/5 HP		
1/5 HP (opt.)			1 kw AC servo motor		
1/8 HP (opt.)			1/4 HP		
Below 78dB (A)					
1700 kg (3740 Lbs)	3250 kg (7150 Lbs)	6000 / 6300 / 6600 kg (13200 / 14520 / 15000 Lbs)	7200 / 7500 / 7800 kg (15840 / 16500 / 17160 Lbs)	8400 / 8700 / 9000 kg (18480 / 19140 / 19800 Lbs)	
1950 kg (4290 Lbs)	3500 kg (7700 Lbs)	6800 / 7100 / 7400 kg (15000 / 15620 / 16280 Lbs)	8100 / 8400 / 8700 kg (17820 / 18480 / 19140 Lbs)	9400 / 9700 / 10000 kg (20680 / 21340 / 22000 Lbs)	
2630 x 1550mm (104" x 61")	3450 x 2050 mm (118" x 79")	4600 x 2300 4600 x 2450 4600 x 2550	4800 x 2300 4800 x 2450 4800 x 2550	6000 x 2300 6000 x 2450 6000 x 2550	
2300 x 1940 x 2200 mm (91" x 76" x 87")	2900 x 2300 x 2250 mm (114" x 91" x 89")	3880 x 2300 x 2280 mm (153" x 91" x 90")	3880 x 2300 x 2280 mm (153" x 91" x 90")	4850 x 2300 x 2280 mm (191" x 91" x 90")	

• With AD5 auto. down feed vertical feed on hand wheel is 2 mm (0.05")/rev. 0.005 mm (0.0001")/gra.

AHR series

Auto. cross feed, longitudinal (hydraulic) and vertical axis travel is by AC servomotor. and operated by MPG. Power rapid up/down operated from buttons on control panel.

PSG-50100AHR

Equipped with auto. cross feed, longitudinal (hydraulic), vertical axis driven by AC servo motor and operated by MPG. The AD5, can be added to become 3-axes fully automated thereby making operation more convenient.