



# THE SQUEAKS

## PINEY WOOD MODEL A FORD CLUB

**VOLUME 49 - ISSUE 3 ---- March - 2023**

### Inside This Issue

**PWA Web Address:** [www.pineywoodmafc.com](http://www.pineywoodmafc.com)

From the President's Desk	2	Sunshine Report	19
Minutes of Meeting	3	Era Fashion	20
February Events	5	Tech Tip	21
PWA Monthly Meeting	7	Out and About	22
MAFCA Presidents Letter	10	PWA Mileage Report for 2022	25
MAFFI Newsletter	11	For Sale	26
Poor Boy tour	12	Supporting Friends	28
Texas Tour 2023	14	PWA History	30
PWA Membership Form	16	Rubber Chicken Award	31
2023 Calendar Events	17	Piney Wood Officers	32

#### MOTTO

To promote and stimulate the preservation, restoration, and maintenance of the Model A Ford automobile

#### QUALIFICATIONS

Any person sincerely interested in the Model A Ford automobile and the purpose of this club shall be eligible for membership as an active member.

# From the President's Desk

By: Jim W Hartzog

We all look forward to the coming of Spring,  
And the wonderful weather that it brings.  
We appreciate the time we have had to get our  
cars in road worthy shape

Our last off site meeting, was hosted by  
Ed Holtgraver at his home.  
It was a real success with an excellent turnout.  
Bob Hitchcock gave an interesting technical  
About headlights. Although many of us try not  
have the opportunity to drive at night, it is  
always good be prepared.

The ladies technical was led by Linda Bragaw.  
They learned how to decorate and display  
beautiful glasses and jars. It was well attended  
and enjoyed by all

Robert Bullard spoke about possibly participating in the annual Pate Swap Meet  
He is extending an offer from our club to have a representative from Pate to attend  
one of our meetings to discuss joining the Pate group. This should be a very  
interesting topic.

We are looking forward to the next breakfast at Lynns table in old town Spring on  
March 4<sup>th</sup>.

Our annual safety inspection will be at Copperfield Automotive on  
March 11<sup>th</sup>. Be sure to bring your own oil, filter etc.

The end of March brings the Poor Boy Tour.

Looking forward to seeing everyone at all the next events.



Jim H

# PWA Meeting Minutes, February 18, 2023

By: Linda Beitler

## **PINEY WOOD MODEL A FORD CLUB Minutes for February 18, 2023 Meeting Ed Holtgraver's Residence**

**Call to order:** President Jim Hartzog called the meeting to order at 10:30 am.

**Invocation:** Paul Gross led the group in prayer.

**Pledge of Allegiance:** Jim Hartzog led the club in the Pledge of Allegiance.

**Minutes:** James Blaszcak made a motion to accept the minutes of the January 10, 2023 meeting. The motion was seconded by Robert Bullard. The minutes were approved.

**Membership Report:** The Membership Report was presented by Perry Jones. Perry advised that there was one new member added in January. He further advised that the membership list has been updated with all who have paid dues for 2023.

**Newsletter:** Troy Walling encouraged the group to forward pictures taken on tours, functions and ladies' activities for the publication in the newsletter.

**Mileage Keeper:** Rich Haut presented patches to club members for miles traveled in a Model A in accordance with the 800 miles per year MAFCA Mileage Award.

**Upcoming Events:** Jim Blaszcak reviewed the upcoming events scheduled to date for 2023 as follows.

- March 4 Monthly Breakfast – Lynn's Table in Old Town Spring (tentative)
- March 11 Annual Safety Check - Copperfield Automotive
- March 14 Monthly Meeting – Valley Ranch Bar B Que
- March 15 Ladies Luncheon
- March 31 – April 2 Poor Boy Tour hosted by Victoria A's

**Texas Tour:** Troy Walling advised that preparations for the Texas Tour to Huntsville in June are falling into place. He further advised that he and Doc Poth would be meeting with the Huntsville Chamber of Commerce and investigating various routes for short tours and attractions around Huntsville shortly.

**Old Business:** Ron Cherry provided an update on the joint project undertaken by the Houston A's and the Piney Wood A's on the restoration of a 1930 Model A Texaco truck. Ron reported that the Texaco truck was started and moved and that the project would be finalized March 25. The location of the restoration is at the 1940's Museum at the airport. Everyone is welcome to come and help.

**New Business:** Robert Bullard discussed the PATE organization as a means of providing the PWA's an annual fundraising event. He provided a brief history of the organization, its ownership structure, its membership provisions and possible funding benefits to member clubs. Robert discussed the organization's annual Swap Meet, to be held in April in Fort Worth at the Texas Motor Speedway. Robert further advised that the Board had approved further investigation and that a representative of the PATE organization will attend the March meeting of the PWA's and give a presentation for further consideration and approval by the membership.

**Adjournment:** A motion to adjourn the meeting was made by Ed Holtgraver and seconded by Troy Walling. The motion passed and the meeting was adjourned at 10:50 am.

**Breakout Sessions:** Bob Hitchcock led the men's technical session on Model A headlights. Linda Bragaw led the ladies on the creation of home decorative pieces using canning jars, wine/liquor bottles, wine glasses and various other jars, special paint and tiny battered operated lights.

# February Events 2023

By: Troy Walling

## Sweetheart Mini Tour February 11



20 cars and 31 people lined up to begin the Sweetheart Mini Tour. The tour began at Magnolia and proceeded through beautiful rural Areas toward Navasota. The group stopped for lunch at Haynies Located in Richards, Texas



Nice quiet drive through the countryside



Everyone enjoyed their lunch with a nice touch by Ilona Blaszcak making the table decorations  
And Kathy Hartzoz making the cookies.  
Thanks to all who participated



PWA Monthly meeting at Ed Holtgravers home  
February 18

**Ladies Technical**



After the monthly meeting, the Ladies' Technical was led by Linda Bragaw Who then conducted a class on using various glasses to make brightly colored items



A beautiful Display is shown with miniture battery lights

## Men's technical



A great presentation was presented by Bob Hitchcock pertaining to the various types of headlight lenses and the method of adjusting the headlight focus



Thanks to Ed Holtgraver for lending us his woodworking shop to the technical. Everyone always enjoys coming here





Congratulations was presented by Rich Haut to the following people for outstanding mileage during 2022

Robert Bullard	13,050
Fred Schiefer	5509
Bob Hitchcock	5084

Honorable Mention	
Ron Cherry	4305

# MAFCA President's Page

---

## February 2023

The end of the year holiday season is in our rearview mirror and we are firmly rooted in 2023. I find January/February a great time to make sure my car events calendar is up to date, get my car ready for safely touring near and far and completing negotiations with Elaine on just how many car events we will participate in. My eyes are always bigger than my stomach so I normally have to pick and choose because I can't do them all.



Car condition and maintenance status is critical for fun, safe and efficient touring. As one of my favorite saying goes: A safe car is a fun car. No one, especially the passenger sitting next to you, enjoys an unreliable car. So now is the time to get her ready. Check your brakes for proper functioning and adjust as necessary. Give the car a thorough check for loose or missing fasteners. Over the course of year, they can work loose and even fall off the car. Check all your bearings and make sure they are properly adjusted and lubed. Eyeball the wiring for nicked or frayed sections and make sure all the grounds are adequate. Depending on how thorough you want to be the list goes on. Check out a maintenance list you can use for reference at the MAFCA.com website; click on References then Downloads. You will find the list under the Technical heading. (Special thanks to the Diablo A's for this web posting.) Everyone touring with you will appreciate your attention to detail.

As I write this newsletter, I received an email from Happy Begg of the Southeastern Touring Group, host of this years National Tour: Backroads to the Classics. She was announcing that Registration for the national tour is now open - The tour is being held in northern Indiana and southern Michigan from July 16 – 21st. The Southeast Touring Group has put together a great agenda with tours to seven different car museums, the Elkhart County Quilt Gardens, Notre Dame University and Basilica of the Sacred Heart and numerous Amish/Mennonite communities in northern Indiana. Sounds like a must do trip and I look forward to seeing you there.

In closing I would like to encourage you to renew your membership in MAFCA for 2023. It is critical so that we all can continue enjoying all the great benefits of being a MAFCA member.

“See you down the road”, Robert Bullard

## MAFFI Newsletter Minute

So...it is well established...you have a deep interest in the Model A Ford, and likely Much more of the Antique & Classic Car Hobby. If you have experienced the incredible Automotive displays at the Gilmore Car Museum in Hickory Corners, Michigan, Home of the Model A Ford Museum, you should really put it on your "bucket list" The Model A Ford Foundation, Inc. (MAFFI) was established in 1986 to preserve the historical significance of the Model A Ford automobile. This was very successfully accomplished by the building of the Model A Museum at the Gilmore. The displays there are updated frequently, giving you a fresh experience each time you visit. Many of our exhibits are interactive and provide an immersive experience for viewers Young and old alike

If you are already a member MAFFI, we thank you for your support. but for those who have not yet joined, please consider the many benefits. First, all paid members and spouses are granted free admission all year to the Gilmore Car Museum campus. Which is worth the price of annual membership

You can also get copies of the original Ford factory photos, articles to share in your local newsletter, and find samples and detailed information on original upholstery material, and Model A advertising. Members will receive a quarterly newsletter. Also can borrow videos on a variety of Model A-related topics.

The operation of the Model A Museum is funded totally through generous donations. And member dues. That's right, one of the most important benefits of belonging to MAFFI is that you are financially supporting the Museum and related programs. Thus allowing you and others to enjoy these benefits for years to come I sincerely hope that you will join our ranks. You can get all the information. You need on the MAFFI website [www.maffi.org](http://www.maffi.org)

You can also support your museum through monetary donations, as well as gifts of Vehicles, parts, tools, era fashions, and other related items. MAFFI is a 501(c)(3) charity; donations are tax deductible. 100% of every donation goes towards operating the Foundation and Museum. What a great way to become a part of the heritage of this special automobile The Model A Ford.

Joe Fox - MAFFI.

# 53<sup>rd</sup> Annual Poor Boy Tour

Hosted by the Victori-A's, Victoria TX  
 Location La Grange TX March 31-April 2, 2023

Registration Fee: \$50 per adult (\$60 after March 15, 2023)  
 \$30 per child under 12 and under

Name(s) of attendee	Adult	Child
1 <sup>st</sup> adult _____	\$ _____	_____
2 <sup>nd</sup> adult _____	_____	_____
_____	_____	_____
1 <sup>st</sup> child _____	_____	_____
<b>Total</b>	<b>\$ _____</b>	

\_\_\_\_\_

Address \_\_\_\_\_ City, State, Zip \_\_\_\_\_

\_\_\_\_\_

Cell Phone \_\_\_\_\_ E-mail \_\_\_\_\_

Model A Year: \_\_\_\_\_ Body Style: \_\_\_\_\_ Will you have a trailer? Yes \_\_\_ No \_\_\_

Club Affiliation (Circle One)    Alamo A's            Houston A's            Piney Wood A's            Victori-A's -

Registration check-in and hospitality room located at the Best Western La Grange Inn & Suites in La Grange will be open after 12:00 pm on Friday until 5:00 pm. The registration includes two meals. The Friday and Saturday evening (6:00 pm) meals are at VFW 500 Veterans Memorial Dr La Grange TX 78945 (located in the fairgrounds).

Please make your check payable to Victori-A Model A Ford Club. Send check and registration form to:  
 Ron Albert, 101 Stockade Dr, Victoria TX 77905.            Contact 956.378.1740

Host Hotel Best Western La Grange Inn & Suites, 600 E State Highway 71 Bypass, La Grange TX 78945, 979.968.6800, [www.bestwestern.com](http://www.bestwestern.com)  
 20 rooms reserved \$116, should be reserved under Model A Ford Club. Make your reservations soon as there is Antique Festival in nearby Warrenton March 16 – April 2. See separate sheet for other hotels & RV Parks.

I hereby release Victori-A Model A Ford Club, Model A Ford Club of America, Model A Restorers Club, including organizers and sponsors of this tour and their facilities from any and all liabilities. Submittal of this form, whether signed or unsigned, constitutes acceptance of this release.

Signed \_\_\_\_\_ Date \_\_\_\_\_

## HOTELS

Best Western La Grange Inn & Suites (Host Hotel)

600 E. State Highway 71 Bypass

La Grange, Texas 78945 979-968-6800 (Ask for Front Desk)

Room Rate \$116 (20 Rooms Blocked) Reserve under Model A Ford Club

Executive Inn & Suites

1708 W. State Highway 71

La Grange, Tx 78945 979-968-2600

Hampton Inn

1624 W. State Highway 71

La Grange, Tx. 78945 979-968-4900

**Information will be forthcoming later on travel plans for our club**

# 2023 Texas Tour WE NEED YOU!



## Meal Planning

- ✓ Route Planning
- ✓ Hotel Selection
- ✓ Conference Center
- ✓ Event Planning
- ✓ Entertainment
- ✓

- ✓ Event Logo
- ✓ City Liaison
- ✓ Much More

**Thanks to the people who have volunteered  
To Lead and Assist in the various activities  
Further details are forthcoming**

See Troy Walling for details.

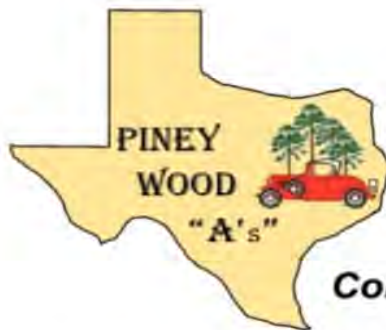

## Texas Tour 2023

June 15-18, 2023

Huntsville, Texas

***Come Join Us On A Great Adventure!***

### **Host Hotels**

***Fairfield Inn & Suites*** (Tour Registration Desk)

136 Ravenwood Village Drive Huntsville, Texas 77340

Room Rates: 50 rooms @ \$109, 19 rooms @ \$149

Phone: (936) 436-7000 Direct

Check-in time 3:00PM

***Holiday Inn Express & Suites***

148 I-45 Huntsville, Texas 77340

All Rooms @\$119

Phone: (936) 295-4300 Direct

***Hampton Inn***, located next to Fairfield Inn & Suites (alternate hotel, but has not signed a contract)

### **Main Event Center**

Walker Education Center Located in the Sam Houston Museum Park

1402 19<sup>th</sup> Street Huntsville, Texas 77340

### **Texas Tour Planned Events**

Short driving tours (Friday)

Grand Tour – Tour the beautiful National Forest (Saturday)

Mystery games

Many points of interest in this historical city such as the Home of Sam Houston (next to the main event center), the Prison Museum, the Military Museum, The statue of Sam Houston, and the Cemetery.

Trailer parking can be arranged.

Great Entertainment at the Award Ceremonies

**Registration Fees will be announced once they are confirmed.**

**Piney Wood Model A Ford Club (PWA)**  
**Membership Application**

One Year Family Membership \$25.00  
Renewal dues are delinquent after December 31<sup>st</sup>

Membership is open to anyone who owns, drives, or just appreciates the Model A Ford. PWA recognizes any year, make or model of the Model A Ford from 1928 to 1931. Membership in the *Model A Ford Club of America* (MAFCA) is REQUIRED to become a member of PWA in accordance with our by-laws. Every member of PWA enjoys the same rights, including the right to vote and to hold office in PWA.

PLEASE PRINT

Date of Application \_\_\_\_\_ Dues being paid for year \_\_\_\_\_ (January 1 – December 31)

New Member (  ) or Renewal (  ) Renewing members, what year did you join PWA? \_\_\_\_\_

Name \_\_\_\_\_ Birthday: Month \_\_\_\_\_ Day \_\_\_\_\_

Spouse \_\_\_\_\_ Birthday: Month \_\_\_\_\_ Day \_\_\_\_\_

Address \_\_\_\_\_ Anniversary: Month \_\_\_\_\_ Day \_\_\_\_\_

City \_\_\_\_\_ State \_\_\_\_\_ Zip \_\_\_\_\_ Email \_\_\_\_\_

Phones: Home \_\_\_\_\_ Cell \_\_\_\_\_ Cell (spouse) \_\_\_\_\_

Children under 18 years of age:

Names \_\_\_\_\_ Birthday: Month \_\_\_\_\_ Day \_\_\_\_\_

\_\_\_\_\_ Birthday: Month \_\_\_\_\_ Day \_\_\_\_\_

\_\_\_\_\_ Birthday: Month \_\_\_\_\_ Day \_\_\_\_\_

What is your MAFCA member number? \_\_\_\_\_ --required for PWA membership

Are you a member of any other automobile clubs?

\_\_\_\_\_ / \_\_\_\_\_

\_\_\_\_\_ / \_\_\_\_\_

Model A's Owned: YEAR, MODEL, BODY STYLE, CONDITION\*

1. \_\_\_\_\_

2. \_\_\_\_\_

3. \_\_\_\_\_

4. \_\_\_\_\_

5. \_\_\_\_\_

\*Condition: O=original, R=restored, B=being restored, M=modified, A=apart

Loanable tools available (ex: spring spreader, engine hoist, hub puller, etc.)

\_\_\_\_\_

Make Check Payable to: Piney Wood Model A Ford Club

Mail to: Perry Jones  
19207 Stanton Lake Dr.  
Cypress, TX 77433  
281-844-0951



# What's On The Calendar?

By: Jim Blaszczak

## 2023 PWA Calendar of Events

Jan 7(Saturday)	PWA Monthly Breakfast at Harris County Smokehouse, 8:00 am-9:00 am
Jan 10 (Tuesday)	Monthly PWA Meeting at Valley Ranch BBQ, 7:00 pm-9:00 pm
Jan 14 (Saturday)	Joint Venture between Piney Wood A's and Houston Model A Club to Return a 1928 Texaco Fuel Truck to running status.
Jan 18 (Wednesday)	Ladies Luncheon at Eden's Café )
Jan 21 (Saturday)	Tomball Museum Center
Jan 28 (Saturday)	Dedication of running 1928 Texaco Fuel Truck back to 1940's Air Terminal Museum at Hobby Airport. Followed by Potluck Lunch
Feb 11 (Saturday)	Sweetheart Mini Tour Team Leader Jim Blaszczak
Feb 18 (Saturday)	Breakfast at Harris County Smokehouse followed by Offsite Monthly Meeting at Ed Holtgravers home 8:00 am - 12:00?
<b>March 4 (Saturday)</b>	<b>Breakfast at Lynns Table in Spring 8:00 – 9:00</b>
<b>March 11 (Saturday)</b>	<b>Safety Check at Copperfield Automotive</b>
<b>Mar 14 (Tuesday)</b>	<b>Monthly PWA Meeting at Valley Ranch BBQ 7:00 pm-9:00 pm</b>
<b>March 15 (Wednesday)</b>	<b>Ladies Luncheon 11:30 am, Location TBD</b>
<b>Mar 31- (Friday)</b>	<b>Poor Boy Tour in La Grange, Tx</b>
<b>April 1-2 (Sat &amp; Sun)</b>	<b>Poor Boy Tour in La Grange, Tx.</b>
April 8 (Saturday)	Breakfast at Harris County Smokehouse followed by Offsite Monthly Meeting at Hartzogs Home 8:00 12:00?
April 15 Saturday)	Burton Cotton Gin Tour Team Leader Bragaws
May 6 (Saturday)	Breakfast at Magnolia Diner 8:00 9:00
May 9 (Tuesday)	Monthly PWA Meeting at Valley Ranch BBQ 7:00 pm-9:00 pm
May 13 (Saturday)	Alton Hues Ranch near Richards, Texas
June	Monthly Meeting (To Be Determined)
<b>Jun 15-18 (Thur-Sun)</b>	<b>Texas Tour in Huntsville, TX</b>
July 11 (Tuesday)	Monthly PWA Meeting at Valley Ranch BBQ 7:00 pm-9:00 pm

August ?	Monthly Meeting (To Be Determined)
Sept. 12 (Tuesday)	Monthly PWA Meeting at Valley Ranch BBQ 7:00 pm-9:00 pm
October ?	Monthly Meeting (To Be Determined)
October ?	Gulf Coast Tour (TBD)
Nov. 14 (Tuesday)	Monthly PWA Meeting at Valley Ranch BBQ 7:00 pm-9:00 pm
Nov. 18 (Saturday)	Tomball Holiday Parade
Dec. 9 (Saturday)	Christmas Party at Walden Yacht Club 13101 Melville Dr. Montgomery, Tx.

During the Monthly Piney Wood Club Meeting on January 10,  
Members were asked to fill out forms for future Ideas for Places to visit.  
Many new locations were suggested as well as old favorites to visit as well.  
Thank you and continue to think of ideas as these trips have.  
Always has been so informative.

# Sunshine Report

By: Perry Jones, Sunshine Coordinator

## New Members

Linda Christy

---

Brandy Fuller	3/6
Vic DeCoster	3/8
Roger Minson	3/8
Ashley Griffin	3/9
Don Endebrook	3/9
Kim Teale	3/10
Annette Haut	3/11
Charles Atkinson	3/13
Phillip Burmaster	3/13
Patrick Moore	3/16
Robert Bullard	3/20
Francis Sample	3/21



---

William & Arnita Hoekstra	3/1
Gene & Evelyn Parrish	3/7
Bill & Connie Miller	3/21
Tom & Alicia Stevenson	3/21

# Era Fashions



Beautiful Original Ad found by Perry Jones

## TECHNICAL TIP - Fan Belt Tightness

- from Sullivan Trail A's

When I first purchased my Model A about 2 years ago, I did the usual base-line maintenance:

- Change oils
- Change radiator fluid
- Grease
- Oiled clevises
- Timed and tuned the car (I got good at this after a few problems with point gap)
- Tightened things that should be tightened, etc.

What I thought was odd was how loose the fan belt needed to be. As we know from reading Les Andrews RED BOOK, the belt needs to be tightened to allow for  $\frac{1}{2}$ " deflection at the midpoint on the belt between the generator and fan pulley. But where is the generator bracket? As it turns out there is not a tensioner bracket. Tightness is maintained by tightening the generator mounting bolt. See figure 1.

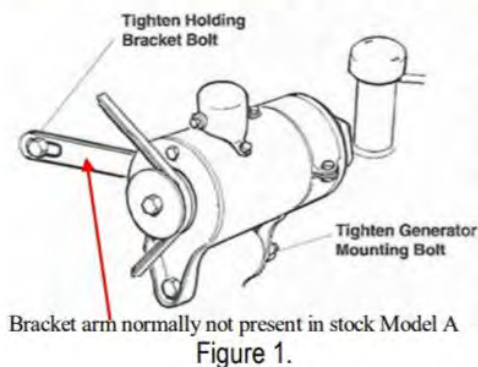

To tighten the bolt it is required that you have a  $\frac{3}{4}$ " socket with a long extension and another wrench. When the bolt is tightened belt tension is maintained so long as the bolt remains tight. What if it were to loosen?

As I have gone on more tours, I have looked under the hood of other Model As and discovered that the owner may have installed an auxiliary bracket. I found that these are available from many of the Model A parts distributors. Very inexpensive insurance (about \$7.00 for the bracket kit) to maintain belt tightness while traveling and also assist in belt adjustment during routine maintenance.

Below in figure 2, is a picture of the kit as purchased with all of the hardware.

To install this bracket requires removal of a bolt on the timing gear cover. Then the bracket is installed with the hardware provided and, in the placement, shown. The curvature of the bracket matches the diameter of the generator. This is about a 15-minute job to install. I view this as an improvement to maintaining fan belt tightness.

NOTE: ALWAYS CARRY A SPARE FAN BELT WHILE DRIVING YOUR A! — just in case.

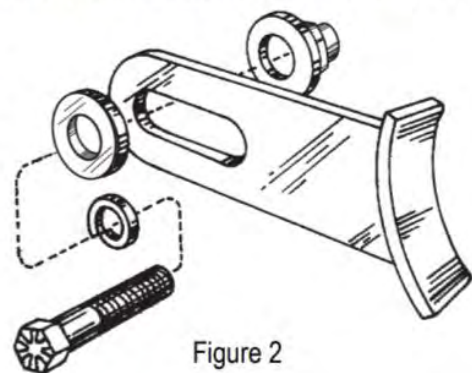

Out and About in the Community  
1940 Air Terminal Museum  
1929 Texaco Fuel Truck

*Model A Ford*  *Club of America*

250 SO. CYPRESS • LA HABRA, CALIFORNIA 90631-5586  
562/697-2712 • 562/697-2737 • FAX 562/690-7452

*January 28, 2023*

*Pine Wood A's - MAFCA - c/o Jim Hartzog, Ron Cherry*

*Houston A's - MARC - Rich Washburn, Michael Eisenbise*

*Gentlemen,*

*On behalf of myself and the MAFCA Board of Directors, I would like to thank you, your respective clubs and members for your joint effort to restore to operation the Texaco-AA Fuel Truck for the 1940 Air Terminal Museum. Elaine and I were able to attend the "commissioning" ceremony on January 28<sup>th</sup> and it was great to see all the volunteers working so diligently to install and get the truck rolling under her own power again. Leonard Nettles was very generous donating an engine that allowed, by end of day, the successful start-up and driving of the truck.*

*All involved demonstrate the special affection given to our Model A hobby and the spirit of cooperation that will benefit both MAFCA and MARC. It was great to be there and enjoy the camaraderie and friendship of everyone. I'm sure The 1940 Air Terminal Museum will gain much use and enjoyment from having a fully functioning Model A to share with museum visitors.*

*A special thanks goes to Ron Cherry (PWA's) and Michael Eisenbise (Houston A's) for serving as technical directors and workday coordinators. Ron, onsite, and Michael, from behind the scenes, are to be congratulated for "herding the cats" from start to finish and getting this project done.*

*Thanks again for letting me take part in the commissioning.*

*Sincerely,*

  
*Robert L. Bullard*

*MAFCA National President 2023*



As our group picture signifies, The Fuel Truck update was attended by many people from the Greater Houston Restorers club and the Piney Wood A's. Thanks to our fellow members in California who donated and delivered the new engine. It was a good day.



Excellent photo of the Historical 40's Air Museum with two of their prize artifacts.



One of the organizers was Gordon Cook (Yellow Shirt) Standing with (Right to Left) Leonard Nettles who donated the engine. James Cameron and George Kulakowski. They drove non stop from California To deliver and help install the engine. These are the types of individuals. Who makes the Model A clubs the envy of many. Thank you, guys.

A special thanks to Michael Eisenbise and all those who participated

**Successful Model 'A' clubs have one common ingredient. They have members that will plan events and volunteer to assist in running the organization. It's a necessary ingredient.**



## PWA Mileage Report – 2022 Final Report

Wow! Did we ever drive this year! We had 20 members report their 2022 mileage. Total miles reported for 2022 was 50,824 compared to 35,453 in 2021, over 10,000 additional miles!! Fantastic!

As y'all know we threw out a challenge to drive 800 miles in 2022 and 20 of us met that challenge and will be receiving these cool patches. Robert Bullard set the pace at 13,050 miles driven in 2022. Not only did he exceed 10,000 miles in 2022, but he has also driven over 50,000 miles for the decade (2013-2022)! Fred Schiefer and Bob Hitchcock both exceeded 5,000 miles for the year! Congrats to these three! The three will receive some nice decals from MAFCA for their accomplishments.

Name		Miles Driven
Last	First	
Bullard	Robert	13,050
Schiefer	Fred	5,509
Hitchcock	Bob	5,084
Cherry	Ron	4,305
Blaszczak	Jim	3,025
Boyles	Jeff	2,578
Haut	Richard	2,101
Bragaw	Tom	1,440
Garrison	Jackson	1,425
DeLucia	Frank	1,246
Walling	Troy	1,245
Campbell	James	1,198
Hoekstra	Bill	1,151
Shaddix	Art	1,144
Jones	Perry	1,074
Fuller	Brandy	951
Nestle	Greta/Steve	941
Teale	David	863
Gross	Paul	806
Walne	Tom	800



A new award for the 800-mile challenge is being developed for 2023. If you are interested in participating, please jot down your starting mileage for 2023 and send it to me so we can track our mileage for the year! Further information about the challenge and the award will be announced soon.

I encourage everyone to jot down your starting mileage for 2023 and send it to me so we can see what our chapter's total mileage is for the year. Whether or not you make it to 800 miles for the year, we sure would like to know how far you did make it!

Rich Haut  
 7 Dresden Place  
 The Woodlands, TX 77382  
[richhaut@gmail.com](mailto:richhaut@gmail.com)

# FOR SALE

By Rex McConnel  
1930 Coupe with Rumble Seat  
Excellent condition with Varco Trunk and two side spares  
Chicle Drab and Copra Drab  
For Information call **936-760-9624** or email **trishmpeterson@comcast.net**



## Wanted

A running Model A in fair condition. \$12,000 range  
Abram Auguste  
Cell 857-342-0981  
Email: [AAuguste@pvamu.edu](mailto:AAuguste@pvamu.edu)

## FOR SALE

Webber Carburetor Model 3236 Setup for your Model A includes everything needed  
Choke Cable, exhaust header cast iron collector, 12-volt fuel pump, pressure regulator

Fuel line and gauge with mounting bracket.

Asking price \$900 or best offer

The original cost was over \$1200 plus shipping

Please contact David Van De Bogert at **262 325 5206**

Or Gregg Zulinski **936 521 9287**



# Supporting Friends Who Support PWA

The following advertisers provide support to our club and the Model A community

Dear Members,

It is very important that we, as a club, support the companies who advertise in our newsletter & directory. Please let them know when you order parts or material, or if you have work done, that you saw their ad in your club newsletter and/or directory.



Web Site: [www.snydersantiqueauto.com](http://www.snydersantiqueauto.com)  
E-Mail: [Don @ SnydersAntiqueAuto.com](mailto:Don@SnydersAntiqueAuto.com)

Snyder's Antique Auto Parts, Inc.  
12925 Woodworth Road  
New Springfield, OH 44443-9753

**Toll-Free!** Orders/Info: 888-262-5712 • Fax: 888-262-5713



Web Site: [www.brattons.com](http://www.brattons.com)

**Brattons Antique Auto Parts, Inc.**  
1606 Back Acre Circle  
Mount Airy, MD 21771

**Order Toll Free:** 800-255-1929  
**Fax Toll Free:** 800-774-1930  
**Information:** 301 829-9880



Web Site: [www.mikes-afordable.com](http://www.mikes-afordable.com)  
E-Mail: [mike @ mikes-afordable.com](mailto:mike@mikes-afordable.com)

**Mikes "A"Ford-Able Parts**  
124 Model A Drive  
Maysville GA 30558

Phone: (706) 652-3866 • Fax: (706) 652-2492



Web Site: [www.snjparts.com](http://www.snjparts.com)  
E-Mail: [smithjones@spiritcom.net](mailto:smithjones@spiritcom.net)  
[snjparts@gmail.com](mailto:snjparts@gmail.com)

**Smith and Jones Antique Auto Parts**  
60 Wisconsin Street  
West Columbia, SC 29170

Phone: (800) 422-1928 • Fax: (803) 822-8477

## Gulf Coast Powder Coating

8140 CAROLYN  
SANTA FE, TEXAS 77517

(409) 925-3262 (409) 770-3228

GCPOWDERCOATING@GMAIL.COM



## Radiator Service

**800-321-4278**

E: info@donhart.com www.donhart.com



## Olde Texas Engine Works

*Have Tools*  
*Will Travel*



Bob Hitchcock (281) 356-6699

General Tune up's and Maintenance  
Mechanical Restoration Sand Blasting and Painting



## Sweet Rides

### Classic Car Restoration

(281) 259-9947



Located at: 1115 Yancey Drive, Magnolia, TX 77355

We are proud to be an Authorized Repair and Restoration Facility HAGERTY CLASSIC CAR INSURANCE



## Fink's Parts and Restoration

1925-1931 Model A Parts  
1932-1948 Flathead Parts  
Model T Parts

Original and Hot Rods  
Punch-in Signs  
50s Trucks

**Randy Fink**  
3302 Fawn Creek Drive  
Kingwood, TX 77339  
785-282-4757  
rfink@att.net



**Jeff Fink**  
Instagram: @jeff\_fink  
jeff@finkparts.com  
785-477-4065  
jfink@ohiostate.com

# TIN MAN

## ANTIQUE LICENSE PLATE RESTORATION

License Plate and Restoration  
Your License Plate Restored

RandallSlack@ (405) 517-2309  
randall.slack@gmail.com

Antique license plates are just that, restored originals. They are not intended to be exact duplicates. Antique license plates have flaws; that is what adds to the "cool factor".

www.alchemymirrorresilvering.com

## ALCHEMY MIRROR RESILVERING

MIRRORS DONE THE OLD FASHIONED WAY

By APPOINTMENT  
TOM & MEGAN TARNOW  
1768 LAUREL AVE.  
ST. PAUL, MN 55104

(651) 641-1125  
alchemy@bitstream.net



Your Ad  
Could Go HERE



## AFTER 45 YEARS LETS LOOK BACK AT SOME PWA CLUB HISTORY

The Following Article, By Gwyn Machacek,  
Entitled "CRANKED UP IN 1977",  
Was Published In Our  
September 1995 & July 2012 Newsletter  
By Paul Lewis:

"For several years there was talk between Model A'ers about trying to form a Model A Club North of Houston and in Montgomery County. Four people said, "Let's try". Notices were posted everywhere in the Spring, Woodlands, and Conroe area telling of the first gathering to be held August 9, 1977 at the Gulf State Auditorium in Conroe. Those four people were Keith Jenkins, Buddy Moore, Larry, and Gwyn Machacek.

Eight families attended the gathering and they all said, "Let's give this club a try". Officers were selected and then one of the big topics of discussion was what can we call ourselves. Suggestions such as; Conroe A's, Montgomery County Motometers, Piney Wood A's, Big Thicket A's and Rambling A's were suggested. It was suggested that a name would be picked at the September meeting. Everyone then browsed through the display of literature on the Model A that Keith Jenkins and Larry Machacek had set up.

At the second meeting the name Piney Wood Model A Ford Club (Piney Wood A's, for short) was chosen and a Newsletter's name "The Ford Squeaks" was selected. Moreover, the club grew by 4 new members.

By the end of 1977, the newly formed club had 16 families. They were Bryant Baugus, Donald & Cindy Chrisner, John & Judy Davidson, Monte Fine, Jerry Fisher, Thomas Gilbert, Dick Hand, Keith & Marlene Jenkins, Benny Klekar, Tom & Joan Lowery, Larry & Gwyn Machacek, Donald Mog, Buddy & Sandy Moore, Guy & Betty Nightingate, Harold & Carolyn Smith, and Thomas Wilkerson.

The following year (1978) saw the club becoming a chapter of the Model A Ford Club of America (MAFCA). Years later, in 1983, the club became a region in the Model A Restorers Club (MARC). **"THE REST IS HISTORY."**

At our 35<sup>th</sup> Anniversary luncheon on July 14, 2012, we all receive a souvenir printout of all the Piney Wood A's meeting minutes for 1977. The club today has far surpassed any vision our founding fathers might have had 35 years ago.

We all should be proud of that as we tack on the future years to come and, be very thankful for that meeting held on August 9, 1977, when **"Let's Give This Club A Try"** received enough "Yes" votes.

# The International Order of the Rubber Chicken

By: Dan Kundts, Chairman of the Board



## the International Order of the Rubber Chicken -Rules, Regulations and Other Silly Stuff-

At a meeting of the International Order of the Rubber Chicken Society (IORCS), the following rules and silly things have been agreed to and enacted upon. The infamous Rubber Chicken is to be fun and full of frivolity. The purpose of these rules is to provide consistency and fairness for those persons desiring (or not) to acquire the scandalous Rubber Chicken.

### Rule #1

If your car causes an unscheduled stop while on tour- **YOU LOST THE CHICKEN!**

### Rule #2

If, while on tour, you delay the group from leaving on time (excepting for bringing donuts & coffee)- **YOU LOST THE CHICKEN!**

### Rule #3

If, after meeting with the group, you have a trailer (or modern car) problem, causing the others to stop alongside the road or be delayed- **YOU LOST THE CHICKEN!** (aka: the Fred Rule)

### Rule #4

If during any tour, you call another tour member to "help, aid, assist, tow, repair or suggest what 'might be the problem'", which causes him/her to stop whatever they are doing - **YOU LOST THE CHICKEN!** (Fred Rule #2)

Rule #5 Passing the Chicken On. Procedures on how to give the chicken away

#### Rule #5-a

To pass the chicken on to another, the current chicken holder must be on said tour.

Rule #5-b. While broken-down on the side of the road, it is NOT advisable to hand over, throw to or put the chicken inside the broken-down car or its owner or driver. Nor is it advisable to stand alongside any broken-down car taunting the car's owner with the chicken. It also not advisable to have a photo with you standing next to the broken vehicle giving a thumbs-up jester (Dorothy Rule). Injury for violating these Rules is at the current chicken holder's own risk.

Rule #5-c. It is appropriate to pass the chicken at any meal once faces have turned from red and steam is no longer venting from ears. -Or- At any chapter meeting. -Or- If the new recipient requests it (while on the side of the road).

### Rule #6

All chapters should name their chicken. It is most appropriate to name the chicken after a member so deserving because of the regularity or quantity of times he/she has had the honorable chicken bestowed up him/her.

### Rule #7

Out of respect, the Rubber Chicken shall be honorably retired once its head or both legs has fallen off.

### Rule #8

Each chapter should appoint a Colonel Chicken whose job shall be to determine all disputed matters. His/her word is final and not open to debate.

### Rule #9

Life Time Achievement Award. The Rubber Chicken shall be permanently given to he/she who run their Model A out of gas while on tour (known as the Pruett Rule of "Don't worry, I have plenty of gas". This is not debatable!  
Note: an appropriate rubber chicken Mardi-gras necklace may be given in lieu of the original rubber chicken.

## 2022 Piney Wood Model "A" Ford Club

### Officer(s) & Chairperson(s)

Jim Hartzog jim.cypress@yahoo.com

### Vice President

Ray Barth raymondjbarth@gmail.com

### Tour Director:

Jim Blaszcak jblaszcak@mac.com

### Secretary & Advertising:

Linda Beitler beitelr@hotmail.com`

### Treasurer:

Frank DeLucia frankdelucia@att.net

### Board of Directors:

James Campbell jlcampb56@hotmail.com  
Ron Cherry ron.cherry2@gmail.com  
Susan Cherry rosesandoldlace@gmail.com  
Chris Fredona cfredona@att.net  
David Teale (Past President)

### Audit:

Tammie Jones (1) jonestg@hotmail.com

### Membership & Email Coordinator:

Perry Jones (jones\_perry@hotmail.com)

### Newsletter:

Troy Walling (troy.39@sbcglobal.net)

### National Reporter:

Jackson Garrison. garrisonja427@gmail.com

### MAFCA, MARC & MAFFI Representative:

Jackson Garrison. garrisonja427@gmail.com

### Safety Coordinator:

Perry Jones (jones\_perry@hotmail.com)

### Chicken Fraternity, Chairman of the Board:

Dan Kundts kundts@Yahoo.com

### Sunshine Coordinator:

Mitzi Shaddix mitzishaddix@gmail.com

### Apparel & Accessories:

Marion Hertzbach bearing1@gmail.com

### Librarian:

Dan Kundts [kundts@Yahoo.com](mailto:kundts@Yahoo.com)

### Technical Seminars:

David Teale dwteale@comcast.net

### 50 - 50 Drawing:

Sergio Fernandez sergiofernandeztxgmail.com

### Christmas Party Committee:

Susan Cherry rosesandoldlace@gmail.com

### Mileage Keeper:

Rich Haut richhaut@gmail.com

### Media Chairperson:

Alex Brock [asbrock@me.com](mailto:asbrock@me.com)

### Lady A Activities Coordinator(s):

Linda Bragaw [tom@go-sail.net](mailto:tom@go-sail.net)



All newsletter mail should be sent the Editor at address:

### *The Ford Squeaks - Piney Wood Model A Ford Club*

Troy G Walling  
40410 Cimarron Way  
Magnolia, TX 77354

[troy.39@sbcglobal.net](mailto:troy.39@sbcglobal.net)

**"The Ford Squeaks"** is the official monthly publication of the Piney Wood Model A Ford Club, Inc. This club is a local chapter of the Model A Ford Club of America (MAFCA), a region of the Model A Restorers Club (MARC). The newsletter is mailed to members, prospective members, and editors of similar publications in exchange for their newsletter. Its purpose is to provide the members with information regarding club activities, upcoming events, Model 'A' restoration and maintenance. Members may publish non-commercial ads at no cost for Model A related items: For Sale, Wanted or Trade. They are also invited to submit articles of interest or information to be published in the newsletter. **Material must reach the Editor by the 20th of the month to insure publication in the next month's issue.** Membership dues in the Piney Wood Model 'A' Ford Club are \$25.00 per year. Annual membership is required in MAFCA. MAFCA dues are \$50.00 per year (subject to change). Membership applications are available from the Club Membership Director or from our website ([www.pineywoodmafc.com](http://www.pineywoodmafc.com)). The Piney Wood Model 'A' Club meetings are held on the 2nd Tuesday of every month (except December) at 7:00PM at the Valley Ranch Bar-B-Que & Grill Restaurant, at the corner of Spring Cypress & Tomball Parkway (FM249). Other clubs are encouraged to use articles & info from **"The Ford Squeaks"** as long as credit is given.

### Community Involvement (OME):

Paul Gross [paulgross@earthlink.net](mailto:paulgross@earthlink.net)

### Model A Tool Crib:

Frank DeLucia [frankdelucia@att.net](mailto:frankdelucia@att.net)