

## Closed Swage Sockets

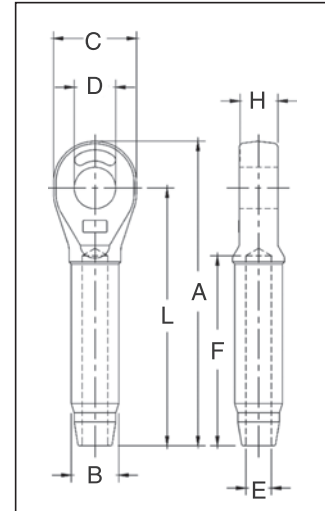

**S-502  
Closed Swage  
Sockets**

- Forged from special bar quality carbon steel, suitable for cold forming.
- Swage Socket terminations have an efficiency rating of 100% based on the catalog strength of wire rope.
- Hardness controlled by spheroidize annealing.
- Stamp for identification after swaging without concern for fractures (as per directions in Wire Rope End Terminations User's Manual).
- Swage sockets incorporate a reduced machined area of the shank which is equivalent to the proper "After Swage" dimension. Before swaging, this provides for an obvious visual difference in the shank diameter. After swaging, a uniform shank diameter is created allowing for a **QUIC-CHECK®** and permanent visual inspection opportunity.
- Designed to quickly determine whether the socket has been through the swaging operation and assist in field inspections, it does not eliminate the need to perform standard production inspections which include gauging for the proper "After Swage" dimensions or proof loading.



**NOTE:** S-502 Swage Sockets are recommended for use with 6 x 19 or 6 x 37, IPS or XIP (EIP), XXIP (EEIP), RRL, FC or IWRC wire rope. Before using any National Swage fitting with any other type lay, construction or grade of wire rope, it is recommended that the termination be destructively tested and documented to prove the adequacy of the assembly to be manufactured. In accordance with ASME B30.9, all slings terminated with swage sockets shall be proof loaded.\*



### S-502 Closed Swage Sockets

S-502 Stock No.	Rope Size		Wt. Each (lbs.)	Ultimate Load** (t)	Before Swage Dimensions (in.)							Max. After Swage Dim. (in.)	Swager / Die Data					
	(in.)	(mm)			A	B	C	D	E	F	H		L	Die Description	Stock No.		Side Load	
															500 Ton 5 x 7	1500 3000 Ton 6 x 12	1500 Ton 6 x 12	3000 Ton 6 x 12
1039325	1/4	6	.33	5.4	4.28	.50	1.38	.76	.27	2.19	.50	3.50	.46	1/4 Socket	1192845	-	-	-
1039343	5/16	8	.75	11.8	5.42	.77	1.62	.88	.34	3.25	.68	4.50	.71	5/16-3/8 Socket	1192863	-	-	-
1039361	3/8	9-10	.72	13.6	5.42	.78	1.62	.88	.41	3.25	.68	4.50	.71	5/16-3/8 Socket	1192863	-	-	-
1039389	7/16	11-12	1.42	18.1	6.88	1.01	2.00	1.07	.49	4.31	.87	5.75	.91	7/16-1/2 Socket	1192881	-	-	-
1039405	1/2	13	1.42	21.3	6.88	1.01	2.00	1.07	.55	4.31	.87	5.75	.91	7/16-1/2 Socket	1192881	-	-	-
1039423	9/16	14	2.92	31.8	8.59	1.27	2.38	1.28	.61	5.38	1.14	7.25	1.16	9/16-5/8 Socket	1192907	-	-	-
1039441	5/8	16	2.85	34.9	8.59	1.27	2.38	1.28	.68	5.38	1.14	7.25	1.16	9/16-5/8 Socket	1192907	-	-	-
1039469	3/4	18-20	5.00	43.5	10.25	1.56	2.88	1.49	.80	6.44	1.33	8.63	1.42	3/4 Socket	1192925	-	-	-
1039487	7/8	22	6.80	51.5	11.87	1.72	3.12	1.73	.94	7.50	1.53	10.09	1.55	7/8 Socket	1192943	-	-	-
1039502	1	24-26	10.40	71.4	13.56	2.00	3.62	2.11	1.07	8.63	1.78	11.50	1.80	1 Socket	1192961	-	-	-
1039520	1-1/8	28	14.82	83.3	15.03	2.25	4.00	2.37	1.19	9.75	2.03	12.75	2.05	1-1/8 Socket	1192989	-	-	-
1039548	1-1/4	32	21.57	109	16.94	2.53	4.50	2.62	1.34	10.81	2.25	14.38	2.30	1-1/4 Socket	1193005	-	-	-
1039566	1-3/8	34-36	28.54	136	18.59	2.81	5.00	2.62	1.46	11.88	2.29	15.75	2.56	1-3/8 Socket	1193023	-	-	-
1039584	1-1/2	38-40	38.06	181	20.13	3.08	5.38	2.87	1.59	12.81	2.56	17.00	2.81	1-1/2 Socket	1193041	1191267	1195355	1195192
1039600	1-3/4	44	51.00	228	23.56	3.40	6.25	3.63	1.87	15.06	3.08	20.00	3.06	1-3/4 Socket	1193069	1191276	1195367	1195209
1042589	2	48-52	89.25	272	27.13	3.94	7.25	3.88	2.12	17.06	3.31	23.00	3.56	2 Socket	1193087	1191294	1195379	1195218

\* Maximum Proof Load shall not exceed 50% of XXIP rope catalog breaking strength. \*\*The Ultimate Loads of 3/4" through 1 1/4" sizes have been increased to meet the requirements for 8 strand 2160 Grade pendants.