

greenworks®

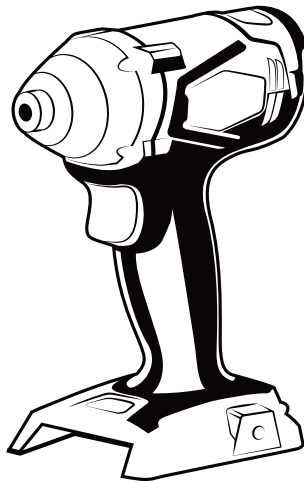

CD24B00

EN	IMPACT DRIVER	OPERATOR MANUAL
FR	PERCEUSE À PERCUSSION	MANUEL D'OPÉRATEUR
ES	ATORNILLADOR DE IMPACTO	MANUAL DEL OPERADOR



ISG301

1	Description.....	4	6.1	Unpack the machine.....	6
1.1	Purpose.....	4	6.2	Install the battery pack.....	7
1.2	Overview.....	4	6.3	Remove the battery pack.....	7
2	General power tool safety		6.4	Install the bit.....	7
	warnings.....	4	6.5	Remove the bit.....	7
2.1	Work area safety.....	4	7	Operation.....	7
2.2	Electrical safety.....	4	7.1	Start the machine.....	7
2.3	Personal safety.....	4	7.2	Stop the machine.....	7
2.4	Power tool use and care.....	4	7.3	Adjust the turning direction.....	7
2.5	Battery tool use and care.....	5	7.4	Operate the machine.....	7
2.6	Service.....	5	8	Maintenance.....	8
2.7	Specific safety rules.....	5	8.1	Clean the machine.....	8
3	Proposition 65.....	6	9	Technical data.....	8
4	Symbols on the product.....	6	10	Limited warranty.....	8
5	Risk levels.....	6	11	Exploded view.....	9
6	Installation.....	6			

1 DESCRIPTION

1.1 PURPOSE

The machine is used to

- drive long deck screws when you assemble a deck,
- drive carriage bolts into deck posts,
- drive screws into block walls and concrete,
- drive screws into metal studs.

1.2 OVERVIEW

Figure 1.

1 Coupler	4 LED work light
2 Reversing button	5 Bit storage
3 Switch trigger	

2 GENERAL POWER TOOL SAFETY WARNINGS

▲ WARNING

Read all safety warnings and all instructions. Failure to follow the warnings and instructions may result in electric shock, fire and/or serious injury.

Save all warnings and instructions for future reference.

The term "power tool" in the warnings refers to your battery-operated (cordless) power tool.

2.1 WORK AREA SAFETY

- **Keep work area clean and well lit.** *Cluttered or dark areas invite accidents.*
- **Do not operate power tools in explosive atmospheres, such as in the presence of flammable liquids, gases or dust.** *Power tools create sparks which may ignite the dust or fumes.*
- **Keep children and bystanders away while operating a power tool.** *Distractions can cause you to lose control.*

2.2 ELECTRICAL SAFETY

- **Power tool plugs must match the outlet. Never modify the plug in any way. Do not use any adapter plugs with earthed (grounded) power tools.** *Unmodified plugs and matching outlets will reduce risk of electric shock.*
- **Avoid body contact with earthed or grounded surfaces, such as pipes, radiators, ranges and refrigerators.** *There is an increased risk of electric shock if your body is earthed or grounded.*
- **Do not expose power tools to rain or wet conditions.** *Water entering a power tool will increase the risk of electric shock.*

- **Do not abuse the cord. Never use the cord for carrying, pulling or unplugging the power tool. Keep cord away from heat, oil, sharp edges and moving parts.** *Damaged or entangled cords increase the risk of electric shock.*
- **When operating a power tool outdoors, use an extension cord suitable for outdoor use.** *Use of a cord suitable for outdoor use reduces the risk of electric shock.*
- **If operating a power tool in a damp location is unavoidable, use a residual current device (RCD) protected supply.** *Use of an RCD reduces the risk of electric shock.*

2.3 PERSONAL SAFETY

- **Stay alert, watch what you are doing and use common sense when operating a power tool. Do not use a power tool while you are tired or under the influence of drugs, alcohol or medication.** *A lapse of attention while operating power tools may result in serious personal injury.*
- **Use personal protection. Always wear eye protection.** *Protective products such as dust mask, non-skid safety shoes, hard hat or hearing protection used appropriately will reduce personal injuries.*
- **Prevent unintentional starting. Ensure the switch is in the off position before connecting to power source and/or battery pack and when picking up or carrying the tool.** *Carrying power tools with your finger on the switch or energizing power tools that have the switch on invites accidents.*
- **Remove any adjusting key or wrench before turning the power tool on.** *A wrench or a key left attached to a rotating part of the power tool may result in personal injury.*
- **Do not over-reach. Keep proper footing and balance at all times.** *This enables better control of the power tool in unexpected situations.*
- **Dress properly. Do not wear loose clothing or jewellery. Keep your hair, clothing and gloves away from moving parts.** *Loose clothes, jewellery or long hair can be caught in moving parts.*
- **If devices are provided for the connection of dust extraction and collection facilities, ensure these are connected and properly used.** *Use of dust collection can reduce dust related hazards.*

2.4 POWER TOOL USE AND CARE

- **Do not force the power tool. Use the correct power tool for your application.** *The correct power tool will do the job better and safer at the rate for which it was designed.*
- **Do not use the power tool if the switch does not turn it on and off.** *Any power tool that cannot be controlled with the switch is dangerous and must be repaired.*

- **Disconnect the plug from the power source and/or the battery pack from the power tool before making any adjustments, changing accessories, or storing power tools.** *Such preventive safety measures reduce the risk of starting the power tool accidentally.*
- **Store idle power tools out of the reach of children and do not allow persons unfamiliar with the power tool or these instructions to operate the power tool.** *Power tools are dangerous in the hands of untrained users.*
- **Maintain power tools. Check for misalignment or binding of moving parts, breakage of parts and any other condition that may affect the power tool's operation. If damaged, have the power tool repaired before use.** *Many accidents are caused by poorly maintained power tools.*
- **Keep cutting tools sharp and clean.** *Properly maintained cutting tools with sharp cutting edges are less likely to bind and are easier to control.*
- **Use the power tool, accessories and tool bits etc. in accordance with these instructions, taking into account the working conditions and the work to be performed.** *Use of the power tool for operations different from those intended could result in a hazardous situation.*

2.5 BATTERY TOOL USE AND CARE

- **Recharge only with the charger specified by the manufacturer.** *A charger that is suitable for one type of battery pack may create a risk of fire when used with another battery pack.*
- **Use power tools only with specifically designated battery packs.** *Use of any other battery packs may create a risk of injury and fire.*
- **When battery pack is not in use, keep it away from other metal objects like paper clips, coins, keys, nails, screws, or other small metal objects that can make a connection from one terminal to another.** *Shorting the battery terminals together may cause burns or fire.*
- **Under abusive conditions, liquid may be ejected from the battery; avoid contact. If contact accidentally occurs, flush with plenty of soap and water. If liquid contacts eyes, immediately seek medical help.** *Liquid ejected from the battery may cause irritation or burns.*

2.6 SERVICE

- **Have your power tool serviced by a qualified repair person using only identical replacement parts.** *This will ensure that the safety of the power tool is maintained.*

2.7 SPECIFIC SAFETY RULES

- **Hold power tool by insulated gripping surfaces, when performing an operation where the fastener may contact hidden wiring or its own cord.** *Fasteners contacting a "live" wire may make exposed metal parts of the power tool "live" and could give the operator an electric shock.*
- **Know your power tool. Read operator manual carefully.** *Learn its applications and limitations, as well as the specific potential hazards related to this power tool. Obey this instruction will reduce shock, fire or serious injury.*
- **Always wear safety glasses with side shields marked to comply with ANSI Z87.1.** *Obey this instruction will reduce the risk of serious injury.*
- **Protect your lungs. Wear a face or dust mask if the operation is dusty.** *Obey this instruction will reduce the risk of serious injury.*
- **Protect your hearing. Wear hearing protection during extended periods of operation.** *Obey this instruction will reduce the risk of serious injury.*
- **Battery tools do not have to be plugged into an electrical outlet; thus, they are always in operating condition. Be aware of possible hazards when not using your battery tool or when changing accessories.** *Obey this instruction will reduce the risk of electric shock, fire, or serious injury.*
- **Do not place battery tools or their batteries near fire or heat.** *This will reduce the risk of explosion and possible injury.*
- **Do not crush, drop or damage battery pack. Do not use a battery pack or charger that has been dropped or received a sharp blow.** *A damaged battery is subject to explosion. Properly dispose of a dropped or damaged battery immediately.*
- **Batteries can explode in the presence of a source of ignition, such as a pilot light. To reduce the risk of serious injury, never use any cordless product in the presence of open flame.** *An exploded battery can propel debris and chemicals. If exposed, flush with water immediately.*
- **Do not charge battery tool in a damp or wet location.** *Obey this instruction will reduce the risk of electric shock.*
- **For best results, your battery tool should be charged in a location where the temperature is more than 50°F but less than 100°F.** *To reduce the risk of serious injury, do not store outside or in vehicles.*
- **Under extreme usage or temperature conditions, battery leakage may occur.** *If liquid comes in contact with your skin, wash immediately with soap and water. If liquid gets into your eyes, flush them with clean water for at least 10 minutes, then seek immediate medical attention. Obey this instruction will reduce the risk of serious injury.*
- **Keep these instructions. Refer to them frequently and use them to instruct others who may use this**

tool. If you borrow someone this tool, loan them these instructions also to prevent incorrect use of the machine and possible injury.

3 PROPOSITION 65

▲ WARNING

This product contains a chemical known to the state of California to cause cancer, birth defects or other reproductive harm. Some dust created by power sanding, sawing, grinding, drilling, and other construction activities contains chemicals known to cause cancer, birth defects or other reproductive harm. Some examples of these chemicals are:







- Lead from lead-based paints;
- Crystalline silica from bricks and cement and other masonry products;
- Arsenic and chromium from chemically treated lumber.



Your risk of exposure to these chemicals varies depending on how often you do this type of work. To reduce your exposure to these chemicals, work in a well-ventilated area, and work with approved safety equipment, such as dust masks that are specially designed to filter out microscopic particles.

Save these instructions.

4 SYMBOLS ON THE PRODUCT



Some of the following symbols may be used on this tool. Please study them and learn their meaning. Proper interpretation of these symbols will allow you to operate the tool better and safer.

Symbol	Explanation
	Read all safety warnings and all instructions
	Wear ear protection
	Low speed
	High speed
	Switching On
	Switching Off

Symbol	Explanation
	Unlock
	Do not touch rotating part

5 RISK LEVELS

The following signal words and meanings are intended to explain the levels of risk associated with this product.

SYMBOL	SIGNAL	MEANING
	DANGER	Indicates an imminently hazardous situation, which, if not avoided, will result in death or serious injury.
	WARNING	Indicates a potentially hazardous situation, which, if not avoided, could result in death or serious injury.
	CAUTION	Indicates a potentially hazardous situation, which, if not avoided, may result in minor or moderate injury.
	CAUTION	(Without Safety Alert Symbol) Indicates a situation that may result in property damage.

6 INSTALLATION

6.1 UNPACK THE MACHINE

▲ WARNING

Make sure that you correctly assemble the machine before use.

▲ WARNING

- If the parts have damage, do not use the machine.
- If you do not have all the parts, do not operate the machine.
- If the parts are damaged or missing, speak to the service center.

1. Open the package.
2. Read the documentation in the box.
3. Remove all the unassembled parts from the box.
4. Remove the machine from the box.

- Discard the box and package in compliance with local regulations.

6.2 INSTALL THE BATTERY PACK

Figure 2.

▲ WARNING

- If the battery pack or charger is damaged, replace the battery pack or the charger.
- Stop the machine and wait until the engine stops before you install or remove the battery pack.
- Read, know, and do the instructions in the battery and charger manual.

- Align the lift ribs on the battery pack with the grooves in the battery compartment.
- Push the battery pack into the battery compartment until the battery pack locks into place.
- When you hear a click, the battery pack is installed.

6.3 REMOVE THE BATTERY PACK

Figure 3.

- Push and hold the battery release button.
- Remove the battery pack from the machine.

6.4 INSTALL THE BIT

Figure 4.

- Push reversing button in the center position to lock the switch trigger.
- Move the coupler forward and hold in position.
- Put bit straight into coupler.
- Release the couple.

i NOTE

Use only impact quality bits with a locking groove.

▲ WARNING

Make sure that you attach the bit tight in the coupler before you use the machine.

6.5 REMOVE THE BIT

Figure 5.

- Push reversing button in the center position to lock the switch trigger.
- Move the coupler forward and hold in position.
- Pull the bit straight out of the coupler.

7 OPERATION

▲ WARNING

Always wear eye protection.

▲ WARNING

Do not use any attachments or accessories not recommended by the manufacturer of this product.

7.1 START THE MACHINE

Figure 6.

i NOTE

The machine can not work until the reversing button is pushed fully to the left or right. Do not operate the machine at low speeds for extended periods of time.

- Push the switch trigger to turn the machine ON (I).

7.2 STOP THE MACHINE

Figure 6.

- Release the switch trigger to turn the machine OFF (O).

▲ WARNING

Release the switch trigger and let the coupler to come to a complete stop.

7.3 ADJUST THE TURNING DIRECTION

Figure 7.

The machine has the reversing button (forward/reverse lock) above the switch trigger to change the direction of the bit.

- When the reversing button is on the left side of the switch trigger, the bit direction is forward.
- When the reversing button is on the right side of the switch trigger, the bit direction is reversible.
- Put the direction button in the OFF (center lock) position to help decrease the possibility of accidental start when not operate.

▲ WARNING

Let the coupler to come to a complete stop before changing the direction of rotation.

7.4 OPERATE THE MACHINE

Figure 8.

- Put the lock-off button in the correct position for the operation.
- Hold the machine with one hand.

- Put the bit on the screw head and slowly push the switch trigger. Start the bit slowly for more control.
- When you drive the screw, work will begin.

8 MAINTENANCE

▲ CAUTION

Do not let brake fluids, gasoline, petroleum-based materials touch the plastic parts. Chemicals can cause damage to the plastic, and make the plastic unserviceable.

▲ CAUTION

Do not use strong solvents or detergents on the plastic housing or components.

▲ WARNING

Remove the battery pack from the machine before maintenance.

8.1 CLEAN THE MACHINE

▲ CAUTION

The machine must be dry. Humidity can cause risks of electrical shocks.

- Clear the unwanted material out of the air vent with a vacuum cleaner.
- Do not spray the air vent or put the air vent in solvents.
- Clean the housing and the plastic components with a moist and soft cloth.

9 TECHNICAL DATA

Coupler	1/4"
Motor	24 V
Switch	VSR (Variable Speed Reversible)
No Load Speed	0 ~ 3,200 / min (RPM)
Impact frequency	0 ~ 4,000 / min (IPM)
Torque	282 N. m (2,500 in. lbs)
Weight with battery	2.67 lbs (1.21 kg)
Battery model	BAM706
Charger model	CAM803

10 LIMITED WARRANTY



Greenworks® hereby warrants this product, to the original purchaser with proof of purchase, for a period of four (4) years against defects in materials, parts or workmanship. Greenworks®, at its own discretion will repair or replace any and all parts found to be defective, through normal use, free of charge to the customer. This warranty is valid only for units which have been used for personal use that have not been hired or rented for industrial/commercial use, and that have been maintained in accordance with the instructions in the owners' manual supplied with the product from new.

ITEMS NOT COVERED BY WARRANTY:

- Any part that has become inoperative due to misuse, commercial use, abuse, neglect, accident, improper maintenance, or alteration; or
- The unit, if it has not been operated and/or maintained in accordance with the owner's manual; or
- Normal wear, except as noted below;
- Routine maintenance items such as lubricants, blade sharpening;
- Normal deterioration of the exterior finish due to use or exposure.

HELPLINE:

Warranty service is available by calling our toll-free helpline, at 1-833-493-5483.

TRANSPORTATION CHARGES:

Transportation charges for the movement of any power equipment unit or attachment are the responsibility of the purchaser. It is the purchaser's responsibility to pay transportation charges for any part submitted for replacement under this warranty unless such return is requested in writing by Greenworks®.

11 EXPLODED VIEW

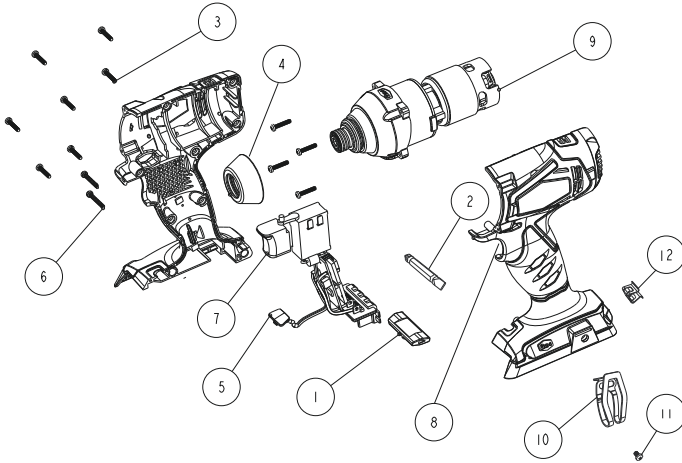

1	34113784A	Forward / Reverse Shifter	1
2	32904784A	Bit	1
3	32205784	Housing Screws	11
4	34200790	Bit Sleeve	1
5	34111784	LED Lamp-Chimney	1
6	32208784A	Screw ST3.5x16-F	2
7	31111796D	Circuit Board Control Assy.	1
8	31109796C	Housing Assy.	1
9	31100796B	Motor and Gear Box Assy.	1
10	33307784	Belt Clip	1
11	32206784	Screw	1
12	33306784	Bit Storage	1

Greenworks Tools
PO Box 1238
Mooreville, NC 28115

FR

1	Description.....	11	6	Installation.....	14
1.1	Objet.....	11	6.1	Déballage de la machine.....	14
1.2	Aperçu.....	11	6.2	Installation de pack-batterie.....	14
2	Avertissements de sécurité pour outils électriques généraux.....	11	6.3	Retrait de pack-batterie.....	14
2.1	Sécurité de la zone de travail.....	11	6.4	Installation de foret.....	14
2.2	Sécurité électrique.....	11	6.5	Retrait de foret.....	14
2.3	Sécurité personnelle.....	11	7	Fonctionnement.....	15
2.4	Usage et entretien d'outil électrique.....	12	7.1	Démarrage de la machine.....	15
2.5	Usage et entretien d'outil sur batterie.....	12	7.2	Arrêt de la machine.....	15
2.6	Entretien.....	12	7.3	Ajustement de sens de rotation.....	15
2.7	Règles de sécurité spécifiques.....	12	7.4	Utilisation de la machine.....	15
3	Proposition 65.....	13	8	Maintenance.....	15
4	Symboles sur le produit.....	13	8.1	Nettoyez la machine.....	15
5	Niveaux de risque.....	14	9	Données techniques.....	15
			10	Garantie limitée.....	16
			11	Vue éclatée.....	17

ISG301

