



Electric Bicycle Owners' Manual

Thanks for your love of our electric RUNDO bicycle (e-bike), and we warmly welcome you to become our user. In order to ensure safe riding, please read the owners' manual carefully. Before knowing the performance of the product, it's recommended not to ride your bike directly on the road. Please keep the owners' manual properly.

Please note the following warnings:

1. Persons below 16 years old are prohibited from riding an e-bike on the road;
2. E-bike with maximum speed no more than the speed required in local policies and regulations should be ridden in the bicycle lane; if there is no bicycle lane, please ride it in the direction specified by local regulations;
3. E-bike shouldn't be borrowed to the person who is unable to manipulate the e-bike, so as to avoid accidents;
4. E-bike can be used to carry persons or goods according to laws and regulations;
5. It's recommended to wear a helmet during riding;
6. If it's ridden in rainy or snowy days, braking distance will be extended; Please avoid riding an e-bike in heavy rain and other bad weathers.

Note:

All data, drawings and technical parameters in the instructions are from the latest products when this instruction book is published. Changes to technical specifications and features improvement due to product changes will not be further noticed.

Contents

Precautions for safe riding.....	3
Drawings of complete bicycle and its parts.....	4
Usage of the displayer.....	5
Inspection before riding.....	9
Safe riding.....	10
Maintenance of battery and motor.....	11
Regular inspection and maintenance.....	16
Terms of warranty.....	19

Precautions for safe riding

Please observe traffic rules and ride the e-bike at a safe speed. Before riding, please know the contents of the instructions in advance and then find an open space for training.

⚠ Warning: Don't lend or let others who are unfamiliar with the e-bikes. Driving with one hand or no hands, or driving after drinking is dangerous.

- Don't park the e-bike in the building's entrance hall, escape stair, aisle, safe entrance and exit.
- Don't charge or park the e-bike in a residential building. During charging, it should be far away from the combustible and charging time shouldn't be too long.
- Please pay more attention to safety when driving the e-bike in rainy and snowy days.
- Wear a helmet correctly.
- Goods loaded on the e-bike shouldn't be too heavy and its rated load is one person.

⚠ Caution:

1. Goods can't be loaded in any part other than the specified position.
2. Please don't put cotton yarns or other similar articles beside the motor.
3. Before riding, please check to ensure proper pressure of the tires, good braking and adequate capacity of the battery.

⚠ Caution:

1. During cleaning, it's prohibited from directly sprinkling water on brake drum, motor and front and rear axles, so as to avoid affecting service performance and life by inflow.
2. Steam or high-pressure water shouldn't be used for cleaning.

Precautions for safe riding

Warning: Don't lend or let others who are unfamiliar with the e-bikes.

Driving with one hand or no hands, or driving after drinking is dangerous.

- During inspection before riding, in case of abnormality, please repair it timely.
 1. Power motor, lighting and braking etc.
 2. Fixation of handlebars and front and rear wheels.
 3. Tires pressure.

Drawings of complete bicycle and its parts

- ① Handlebar
- ② Brake Level
- ③ Stem
- ④ Battery
- ⑤ Wheel
- ⑥ Fork
- ⑦ Disc Brake
- ⑧ Rim
- ⑨ Pedal
- ⑩ Rear Derailleur
- ⑪ Motor
- ⑫ Seat Stem
- ⑬ Saddle

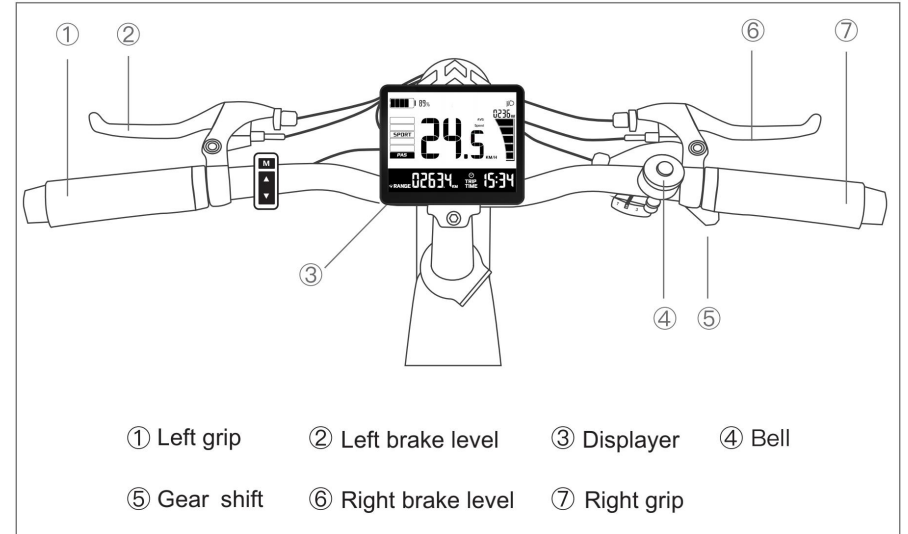
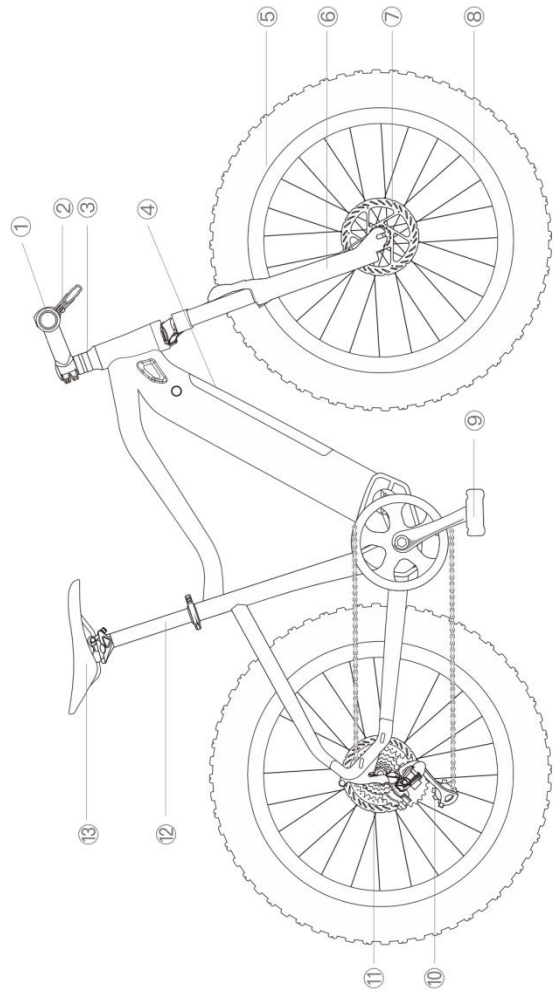

- ① Left grip
- ② Left brake level
- ③ Displayer
- ④ Bell
- ⑤ Gear shift
- ⑥ Right brake level
- ⑦ Right grip

Usage of the displayer

Description of appearance



Product is mid-mount on the horizontal tube with a handlebar size of ϕ 22.2mm, ϕ 25.4mm, ϕ 31.8mm. The remote control is left mounted on the horizontal tube with a handlebar size of ϕ 22.2mm, ϕ 23.8mm.



1. Power button: Turn on/off the display
2. Adjust button: Adjust the assisting power level during riding and switch functions. Long press the adjust buttons to perform specific function operation
3. Function button: Switch interface functions and enter into parameter setting interface

• Assist level switch

Short press buttons to switch PAS level. There are five PAS levels ECO/TOUR/SPORT/TURBO/BOOS, When PAS level is empty, it means no pedal assist power output, that is PAS off state.

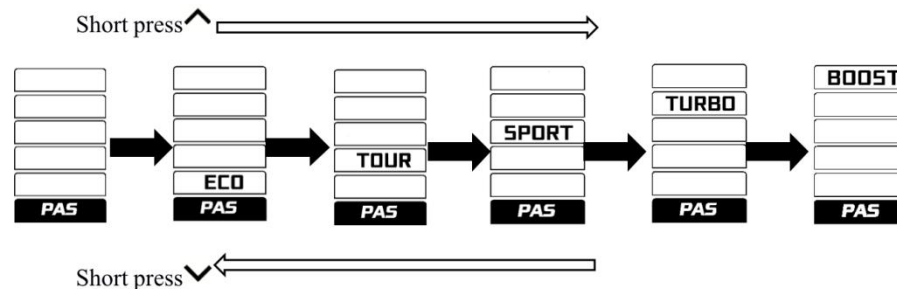

PAS level does not switch in cycles, that is after reaching BOOST level, short press to return to PAS off level. It's the same when adjusting up.

General Operation

• Switching the eBike System On/Off



When display is properly connected with controller, turn on the display by long press button until boot logo interface appears and shortly enters the basic interface. Turn off the display by long press button until display is turned off.

If the rider does not perform any operation on the display within set sleep time, while speed is 0, and current is less than 1A, then the display will be turned off automatically. Set sleep time is self-defined by user in setting interface.

• Battery Indicator

Battery power information is divided into battery bar indication and remaining percentage indication. When battery power is normal, battery capacity is divided into 5 bars.

SOC	Battery level	Description
80% ≤ SOC		Full battery level 5
60% ≤ SOC < 80%		Level 4
40% ≤ SOC < 60%		Level 3
20% ≤ SOC < 40%		Level 2

10% ≤ SOC < 20%		Level 1
5% ≤ SOC < 10%		Level 0
0% ≤ SOC < 5%		Level 0 and icon blink at 1Hz

Error code definition

Error code	Error description	Suggest operation
"04" shown at speed	throttle doesn't turn back to zero position (stay on the high position)	Check if the throttle turned back
"05" shown at speed	throttle failure	Check throttle
"07" shown at speed	<u>overvoltage</u> protection	Check battery voltage
"08" shown at speed	failure of motor's hall signal wire	Check motor
"09" shown at speed	failure of motor's phase wire	Check motor
"11" shown at speed	failure of the motor's temperature sensor	Check controller
"12" shown at speed	failure of the current sensor	Check controller
"13" shown at speed	failure of the temperature of the battery	Check battery
"14" shown at speed	Controller temperature is too high, and reaches the protection point	Check motor
"21" shown at speed	failure of the speed sensor	Check the install position of the speed

Inspection before riding

Before start-up: you need to stand in the left side of the bicycle to erect the main support and check whether the complete vehicle is abnormal.

Tire inspection

1. Tires pressure: Pressure of the tire should be judged according to sunken condition of the tire at the grounding part. In case of abnormal pressure, tire measurer should be used for inspecting and adjusting to normal pressure.

Generally, normal pressure of front wheel is 250KPa.

2. Whether the tires have fracturing or abnormal wear.

3. Whether there are embedded nails, stones or glasses in the tires.

⚠ Caution: steering failure and tire burst are caused by abnormal tire pressure, crack, damage and abnormal wear of the tires.

4. The tire should be replaced when depth of tire groove and bump of the tire have been worn off by 2/3.

Inspection of lights

1. Operate lighting switch to check whether front light and tail light are ON and whether beam of front light is normal.

2. Check the front and the rear brake handles respectively to see whether the power is disconnected.

3. Please be sure to check whether the light is damaged, so as to not affect riding.

Inspection of handlebars and front and rear wheels

1. Swing the handlebars to the upper, lower, left, right, front and back to see whether it's loose. Screws can be tightened for fixation.
2. Determine whether front and rear wheels are fixed normally.

Safe riding

Start

Long-press Power-on key to start up and check whether each switch button works and whether the brake switch is normal. If there is no abnormality, the kickstand should be placed horizontally and grounded to the earth through rear wheel.

Shifting system

Gear shift are located at the right handlebar. According to personal riding demand, upper and lower controllers can be stirred to adjust different gears, so as to achieve the effect of changing riding speed and strength.

Shifting system

It's required to firstly brake rear wheel and then brake the front wheel.

⚠ Caution: It's dangerous to only brake the front wheel or the rear wheel, as it may cause sideslip of the e-bike.

Stop method

1. Slow down and approach the parking place.
2. Long-press power-on button to turn off the power supply when the bike is totally stopped.

Maintenance of battery and motor

Opening of the battery box: key to battery lock is inserted into the keyhole and rotated clockwise, Press and hold the battery and push to the left, so as to smoothly take out the battery.

Charging and maintenance of the battery

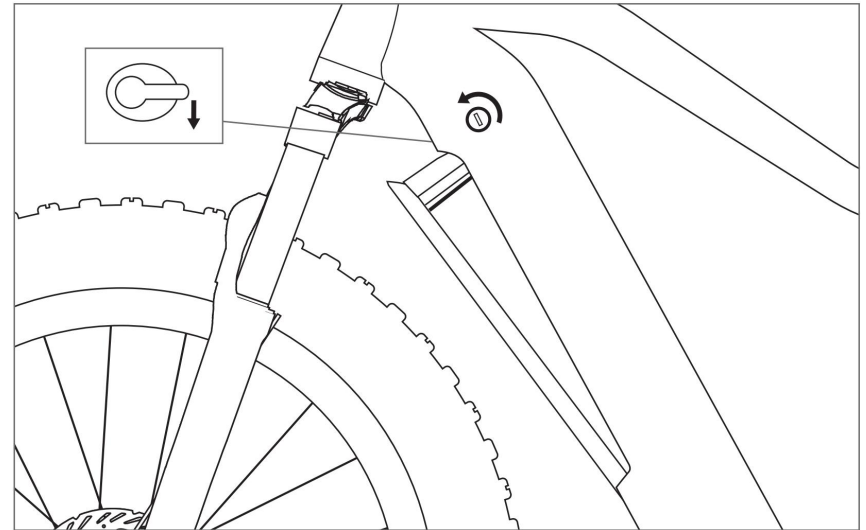

1. The bike must be charged by our specific charger. Non-standard or unqualified charger may cause loss of service life of the battery or failure of the battery.
2. Battery detection method: Press the battery status button to know the current battery level through the battery status indicator color.
3. The battery discharged completely can be charged with more than 95% electric quantity in 5 hours and 100% electric quantity in 8 hours.

4. During charging, it's prohibited from directly using metal to contact positive and negative anodes.
5. Upon delivery of the product, its electric quantity is about 80% and new products need to be charged for 3-10h before being used.
6. If the bike has been put aside for more than 1 month, the battery electric may be decreased by 5%. So, it's suggested to charge before using.
7. During charging, charger may heat and it's normal if the temperature under 60°C.
8. During charging, charger and battery should be placed in a stable and dry place without flammables and combustibles beyond access of the children.
9. Do not short circuit the charging port.
10. The battery can only be used for our e-bike, and can't be used for other purpose.
11. It is prohibited from storing the battery with insufficient voltage for a long time.
12. Service environment should be at -10°C~55°C. When beyond this scope, it may affect capacity and service life of the battery. When used in a low temperature, its endurance mileage may be shortened and recovered after temperature rise.
13. If the battery needs to be replaced, please contact with a professional maintenance site. Waste battery can't be discarded randomly or disassembled arbitrarily. It should be recycled by relevant department.

Usage and maintenance of the charger

Appearance of the charger

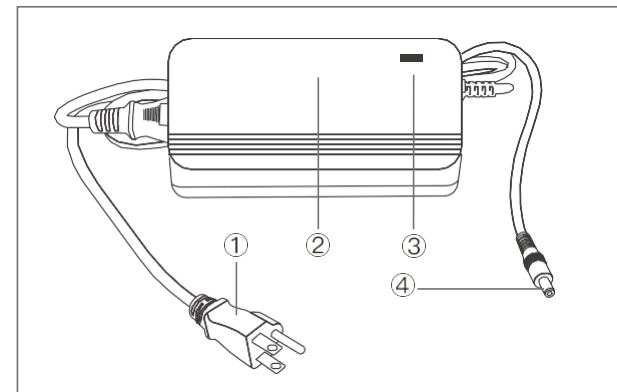

- ① Power plug
- ② Charger case
- ③ Charger indicator
- ④ Charging plug

It's required to carefully check whether rated input voltage of the charger is consistent with network voltage. The battery can be directly charged on the bike, or removed from the bike and taken to the indoor and other appropriate places for charging. It should be charged indoors in cold winter areas.

Please connect the output plug of the charger to the charging jack of the battery first, then connect the input plug of the charger to AC power, and the red indicator light will be on. This procedure is prohibited from reverse operation.

At this time, red charging indicator of the charger is on, which means that the battery is charging; if the green light is on, it means that the battery has been fully charged. The charging time is about 3~8 hours (specific charging time should depend on the residual electric quantity of the battery).

Maximum continuous charging time should be no more than 12 hours.

Charging without disassembly of the battery

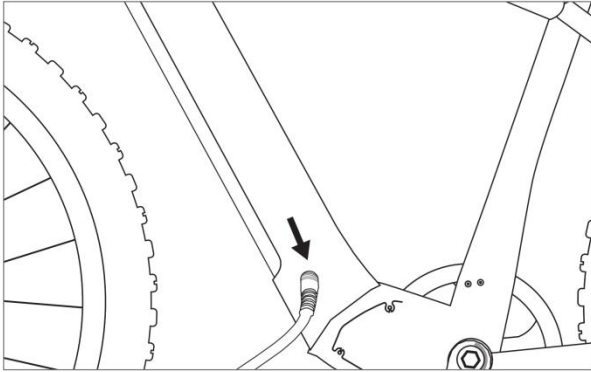

1. Open the power system cover on the left side of the bike, you will see the charging socket of the battery.
2. Connect the charger power plug to the outlet of the specified voltage.
3. Plug the charger's charging plug into the battery's charging socket and start charging.

Charging with disassembly of the battery

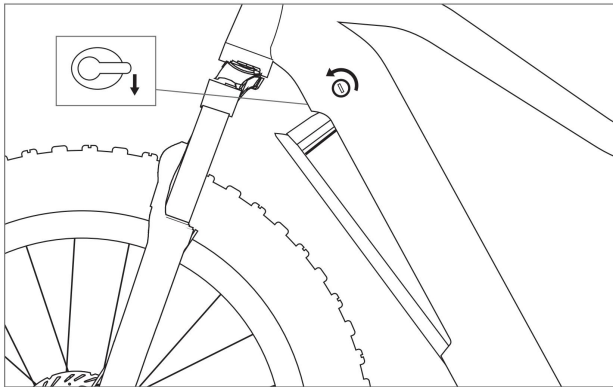

1. Insert the key into the lock hole and turn it counterclockwise. Pull down the battery.
2. Power plug of the charger is connected to a socket with specified voltage.

3. Plug the charger's charging plug into the battery's charging jack and start charging.

Instructions of the charger

1. Charging should be implemented by the user according to the instructions. Otherwise, all consequences should be assumed by the user independently.
2. Original charger should be used only.
3. Attention should be paid to type and applicable voltage of the battery which is applicable for the charger. Mixed using is strictly prohibited.
4. During charging, it should be placed in a ventilated environment; it's strictly prohibited from charging in a closed space or burning sun and high temperature environment;
5. It should be charged for 1-2 hours again after fully charged and then, the power supply can be cut off. During non-charging, it's prohibited from connecting the charger to AC power supply at a no-load condition for a long time;
6. During charging, if the indicator light is abnormal, has peculiar smell or the charger case is overheating, it's necessary to stop charging immediately and repair or replace the charger;
7. During the use and storage of the charger, be careful to avoid foreign matter entering, especially to avoid water or other liquids, so as to avoid internal short circuit of the charger. The charger should not be carried with the car as much as possible. If it is necessary to carry it, it should be placed in the toolbox after the suspension treatment is completed.

8. Components of the charger shouldn't be disassembled or replaced randomly.

If the charger is replaced, its model should match with model of the battery.

Regular inspection and simple maintenance

In order to lengthen service life of the bike and realize safe and comfortable riding, it's necessary to regularly check and maintain. If the bike isn't used for a long time, it should also be checked regularly.

Sufficient attention should be paid to safety during inspection.

Main support should be set up in a wide and flat place. If inspection is required during riding, it should be conducted in a safe place and attention should also be paid to safety in the surroundings at the same time. If abnormality is found through inspection, please ride it again after troubleshooting.

If you don't have a professional mechanical tool measurer, please check and replace in a nearby maintenance station and don't disassemble it independently before grasping the technology, so as to avoid damaging or losing other components.

Common troubleshooting of the e-bike

No.	Fault	Fault Cause	Troubleshooting
1	Speed regulation fails or maximum speed is low	(1) Battery voltage is too low; (2) Connection of speed regulating handlebar is loose; (3) Spring in the speed regulating handlebar is stuck or invalid	(1) Charge the battery fully; (2) Clamp tightly after insertion again; (3) Ask the supplier for replacement.
2	Motor hub doesn't work after power-on	(1) Battery wiring is loose; (2) During power-off, left and right brake handles are invalid; (3) Connection plug of motor hub is loose or damaged.	(1) Repair and connect again; (2) Repair and assemble again; (3) Ask a professional person for repair or repair at a maintenance station.
3	Follow-up riding mileage after a charge is insufficient	(1) Tire pressure is insufficient; (2) Insufficient charging or fault of the charger; (3) The battery is aging or damaged; (4) There are lots of uphill, heavy dead wind, frequent brake and startup and large load.	(1) Charge gas fully; (2) Charge fully or inspect whether plug of the charger is contacted well; (3) Replace the battery; (4) Suggesting using manual pedal-lift assistance in such conditions

No.	Fault	Fault Cause	Troubleshooting
4	Charger can't be used for charging	(1) Socket of the charger falls off or connection of plug and socket is loose; (2) Fuse in the charger is burnt out; (3) Wiring of battery set falls off.	(1) Fasten connector assembly of the socket box; (2) Replace the fuse; (3) Weld connecting cables.
5	Other faults	(1) When you have fault which can't be independently solved or judged under guidance stated above; (2) When motor hub, controller, charger and battery set are damaged.	In case of above conditions, please seek help from the supplier or maintenance station. Please don't open above components arbitrarily; otherwise, you will not enjoy warranty commitment of the Company.

TERMS OF WARRANTY

- This warranty only applies to the original owner of the our bike unless otherwise determined by applicable mandatory legislation.
- Proof of purchase is required for all warranty claims.

Limited two years warranty

Includes: Battery.

Battery is warranted to be free from manufacturer defects in materials and/or workmanship for a 2-year-period from the date of original purchase

(For Battery: cycle life or deep charge up to 70% full capacity).

This Limited Two Years Warranty covers replacement parts ONLY and does NOT cover the cost of shipping or installing the replacement parts.

Limited one years warranty

Includes: Motor, Controller, Dashboard, Charger.

These items are warranted to be free from manufacturer defects in materials and/or workmanship for a period of one year from the date you receive your our bike. This warranty does not cover normal wear and tear.

This Limited One Year Warranty covers replacement parts ONLY and does NOT cover the cost of shipping or installing the replacement parts.

- This warranty does not cover any damages or defects resulting from failure to follow instructions in the owner's manual, acts of God, accident, misuse, neglect, abuse, commercial use, modification, or improper assembly.
- This warranty does not cover normal wear and tear of the bike or its components (for example: tires, inner tubes, brake pads, chains, etc.).

- This warranty does not cover any unauthorized modifications done to the bike and/or its components.
- Our Bike reserves the right to refuse any warranty claim

No warranty

- Faults caused by usage, maintenance and adjustment of the user without complying with the “Instructions”.
- Faults caused by user random disassemble, repair, refit and non-compliance of instructions.
- Faults caused by improper storage of the user, accidents, or irresistible force, such as flood and firing etc.
- There isn't warranty card, invoice or not our invoice or card.
- Fragile and consumable products without warranty, such as brake cable, bulb and tire etc.
- Parts damaged during random disassemble beyond the scope specified in the instructions.