



The FuelTainer versatile range come complete with ISO, CSC & UL142 approvals and are a containerised tank design

Available Sizes

- ✓ FTV-12000L/3128G
- ✓ FTV-17000L/4491G
- ✓ FTV-30900L/8163G
- ✓ FTV-38000L/10039G
- ✓ FTV-68000L/18234G
- ✓ FTV-75000L/19813G



FUELTAINER
versatile



FUELTAINER

VERSATILE

Enhanced Design Features

Unique Design Standard

The FuelTainer Versatile Bunded Tank with its rectangle shape is an innovative unique tank design and has become the go-to bulk fuel storage tank solution for industry leaders world wide.

Maintenance & Environment

To ensure efficient cleaning and maintenance can take place the tanks have been designed with manway cover lids and an internal integrated ladder system allowing easy access inside the tank to reach the inner tank floors. This innovative design allows flexible inspections top take place and insures a minimal amount of downtime.

Dispensing & Accessibility

The FuelTainer versatile Tank comes equipped with a spacious secure equipment compartment area which can house various dispensing pumps and fuel and management systems. It comes with over-head pylons and integrated dispensing hoses & nozzles, allowing the bulk tank to work as a safew and secure independent stand alone fuel station.

Transportable & Portable

All FuelTainer versatile tanks have been designed to be easily transported when empty. They come with there own ISO twist locks allowing them to be fixed onto 40ft flat bed trucks and transported over long distances by road.



Proven Design

Take a look inside

The Class leading FuelTainer versatile tank range is an ISO,CSC double wall tank design, featuring a fully integrated 6mm inner tank and a 6mm outer protection tank. The range comprises large double cargo doors which open up to a large equipment compartment area allowing the easy up-fitting of various pumps, reels ,flow meters, filters, dispensing equipment and Fuel management systems. Designed as static tanks they are portable when empty and are suited to many fuel and fluid applications world wide.

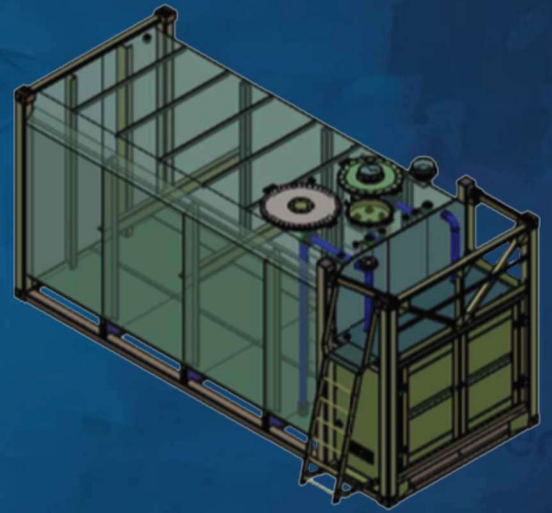

Superior Features

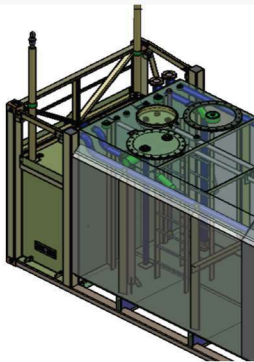

Multiple Ports fittings and Down pipes designed to accommodate various applications

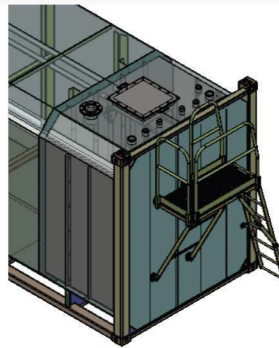

Collapsible ladder and walkway design for ease while in transit.

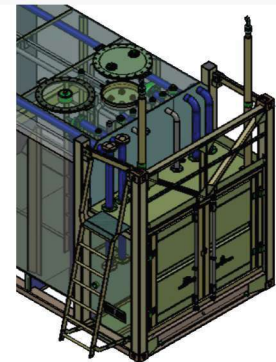

Large double container doors securing an extra large equipment compartment area.

Optional Accessories



Fuel and Fluid Dispensing Nozzle and Flow Meter Console Options.



Spill Control Floor with Bracket system and retractable hose reel Options.



Filter Options that offer the removal of sediment, scale, rust and water particles from Diesel.

FUELTAINER

VERSATILE

Model (FTV-12000L / 3128G)

The FuelTainer Versatile tank is a class leading innovative double wall tank design that provides safe and secure storage dispensing of fuel & fluids. The tank easily fitted with various pumps , reels , flow meters , filters & dispensing systems



Specifications

	Metric	US	Imperial
Capacity	11264 Litres	2976 Gallons	2478 Gallons
Length	2991 mm	117 12/16"	117 12/16"
Width	2438 mm	95 15/16"	95 15/16"
Height	2896 mm	51"	51"
Outer Tank Thickness	5 mm	3/16"	3/16"
Inner Tank Thickness	5 mm	3/16"	3/16"
Weight, Tare	4391 kg	9680 lbs, 8oz	9680 lbs, 8oz
Weight, Laden	13487 kg	29733 lbs, 12oz	29733 lbs, 12oz
Safe Fuel Fill Level	10700 Litres	2354 Gallons	2827 Gallons

Approvals and Certifications

UK & Europe

- ✓ Lifting When Empty
- ✓ CSC
- ✓ ISO688
- ✓ AS1940
- ✓ UL 142
- ✓ AS1682 CAT.3
- ULC S601

Optional

- ✓ BS799

USA & Canada

- ✓ CSC
- ✓ ISO688
- ✓ Lifting When Empty
- ✓ UL 142
- ✓ ULC S601

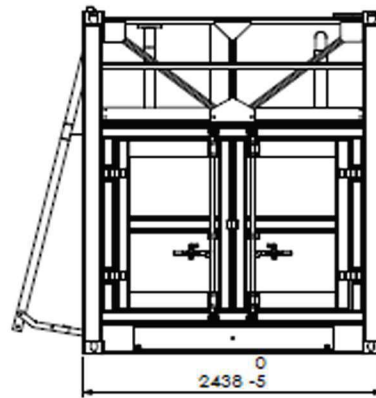
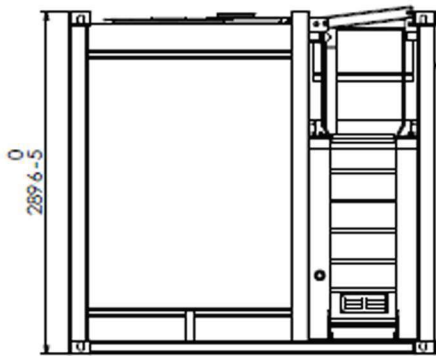
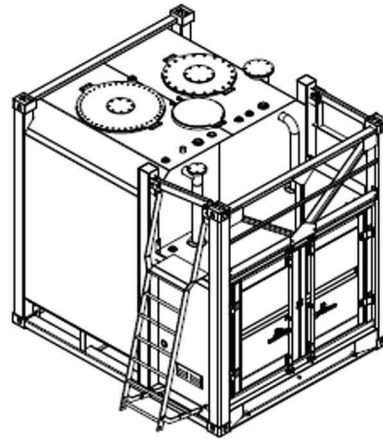
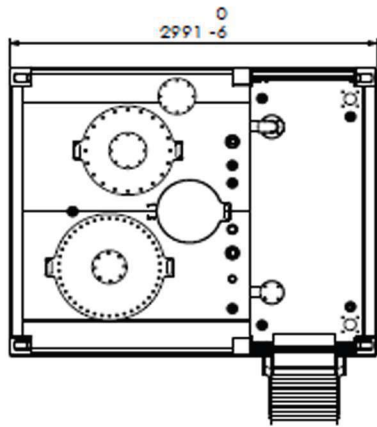

The FuelTainer versatile tank features a large equipment compartment area designed to host various Pumps, Dispensing Stations and STPs brands. Examples shown in the exploded images below.



Fuel Management console Panel



Diesel dispensing station with Dispensing nozzle 80LPM



Red Jacket Submersible Turbine Pump



Blackmer GNX Series pumps provides flow capacities from 7 to 500 gpm (25 to 1,893 L/min)

FUELTAINER

VERSATILE

Model (FTV-17000L / 4491G)

The FuelTainer Versatile tank is a class leading innovative double wall tank design that provides safe and secure storage dispensing of fuel & fluids. The tank easily fitted with various pumps , reels , flow meters , filters & dispensing systems



Specifications

	Metric	US	Imperial
Capacity	17790 Litres	3913 Gallons	4700 Gallons
Length	2991 mm	117 12/16"	117 12/16"
Width	2438 mm	95 15/16"	95 15/16"
Height	2896 mm	114"	114"
Outer Tank Thickness	5 mm	3/16"	3/16"
Inner Tank Thickness	5 mm	3/16"	3/16"
Weight, Tare	4261 kg	9393 lbs, 14oz	9680 lbs, 8oz
Weight, Laden	22061 kg	48636 lbs, 3oz	48636 lbs, 3oz
Safe Fuel Fill Level	16900 Litres	3717 Gallons	4465 Gallons

Approvals and Certifications

UK & Europe

- ✓ Lifting When Empty
- ✓ CSC
- ✓ ISO688
- ✓ AS1940
- ✓ UL 142
- ✓ AS1682 CAT.3
- ULC S601

Optional

- ✓ BS799

USA & Canada

- ✓ CSC
- ✓ ISO688
- ✓ Lifting When Empty
- ✓ UL 142
- ✓ ULC S601

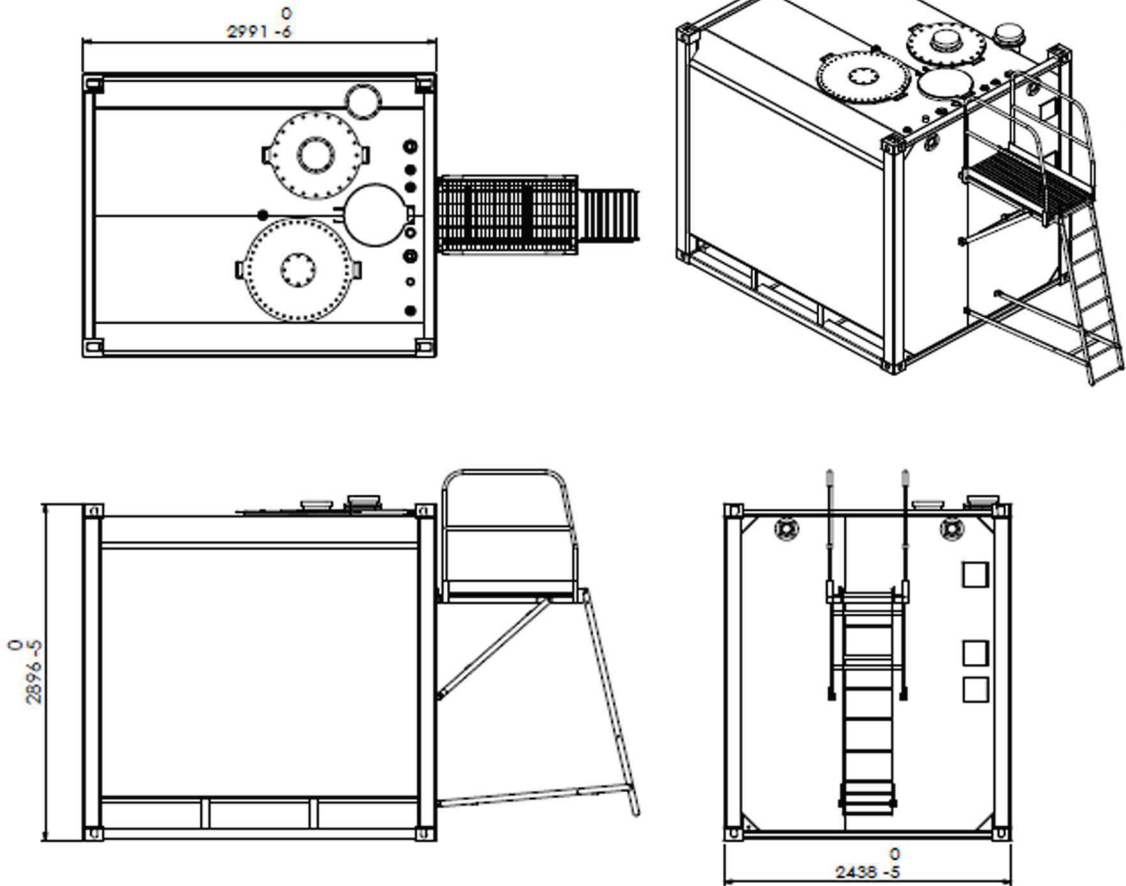

3" Incoming pipe work, male camlock, cap, 80mm fire safe ball valve, wafer check valve, mechanical overfill prevention valve. 3" Discharge pipe work with foot valve.



Male Camlock with cap, 80mm fire safe ball valve.

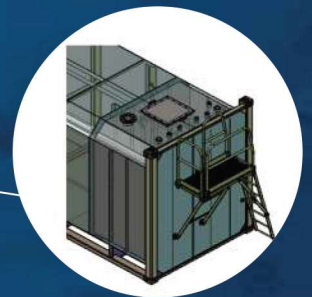

Collapsible ladder and walkway design for ease while in transit.

FUELTAINER

VERSATILE

Model (FTV-30900L / 8163G)

The FuelTainer Versatile tank is a class leading innovative double wall tank design that provides safe and secure storage dispensing of fuel & fluids. The tank easily fitted with various pumps , reels , flow meters , filters & dispensing systems

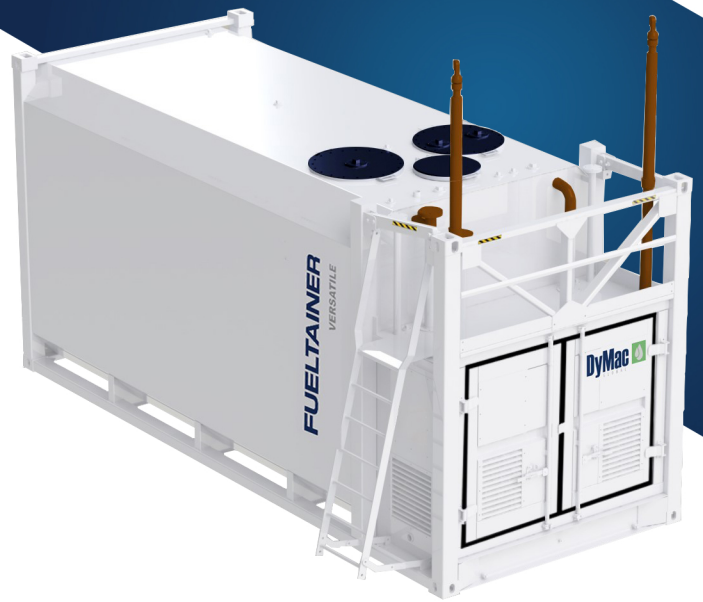

Specifications

	Metric	US	Imperial
Capacity	30901 Litres	8163 Gallons	6797 Gallons
Length	6058 mm	238"	238"
Width	2438 mm	95 15/16"	95 15/16"
Height	2896 mm	114"	114"
Outer Tank Thickness	6 mm	3/16"	3/16"
Inner Tank Thickness	6 mm	3/16"	3/16"
Weight, Tare	7695 kg	16964 lbs, 9oz	16964 lbs, 9oz
Weight, Laden	32647 kg	71974 lbs, 5oz	71974 lbs, 5oz
Safe Fuel Fill Level	29350 Litres	7753 Gallons	6456 Gallons

Approvals and Certifications

UK & Europe

- ✓ Lifting When Empty
- ✓ CSC
- ✓ ISO688
- ✓ AS1940
- ✓ UL 142
- ✓ AS1682 CAT.3
- ULC S601

Optional

- ✓ BS799

USA & Canada

- ✓ CSC
- ✓ ISO688
- ✓ Lifting When Empty
- ✓ UL 142
- ✓ ULC S601

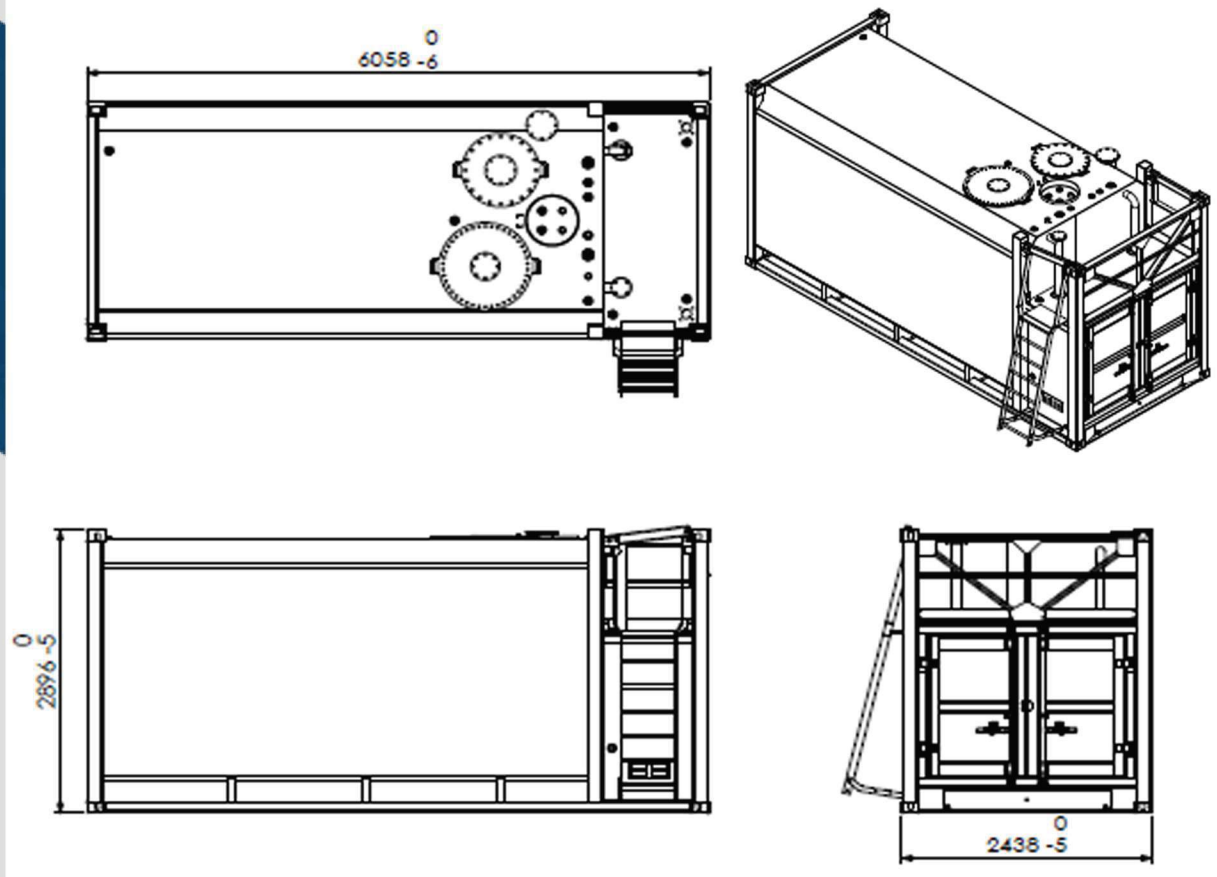

The FuelTainer versatile tank features a large equipment compartment area designed to host various Pumps, Dispensing Stations and STPs brands. Examples shown in the exploded images below.

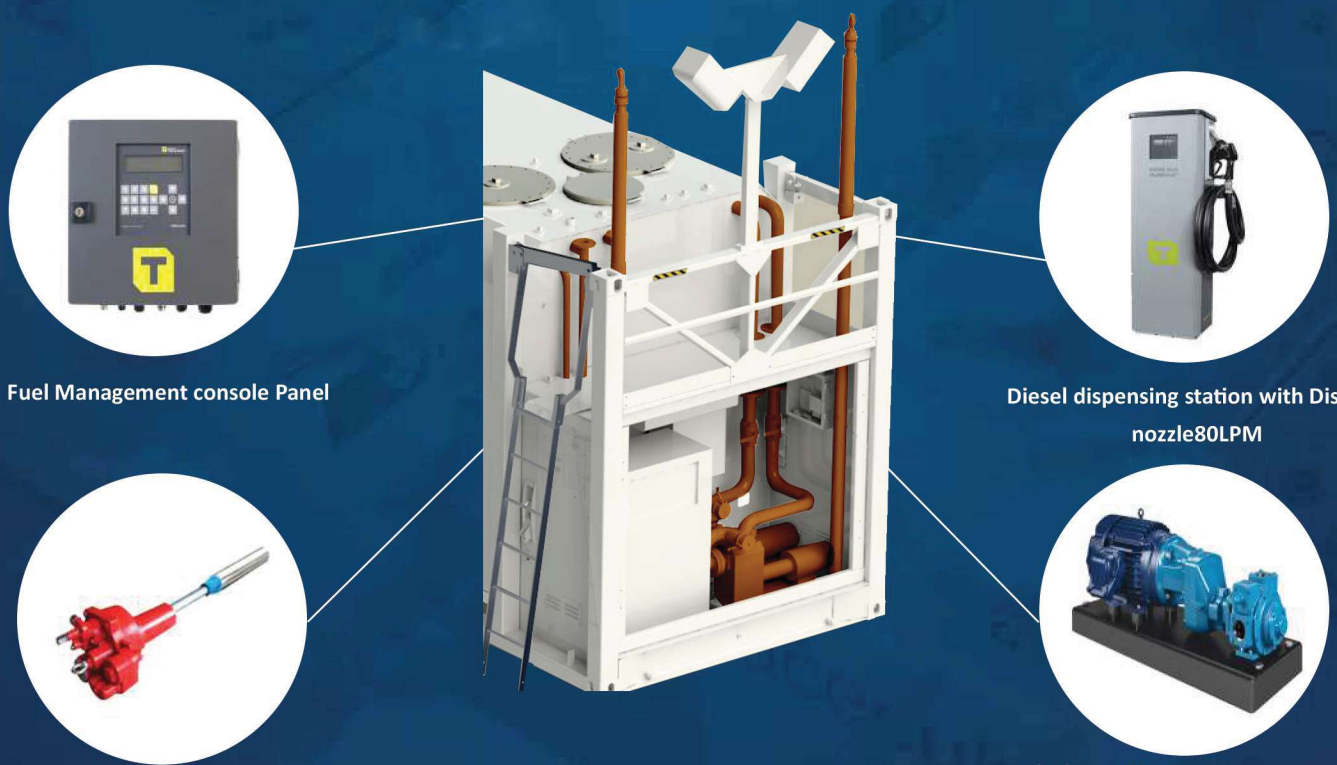

Fuel Management console Panel

Diesel dispensing station with Dispensing nozzle 80LPM

Red Jacket Submersible Turbine Pump

Blackmer GNX Series pumps provides flow capacities from 7 to 500 gpm (25 to 1,893 L/min)

FUELTAINER

VERSATILE

Model (FTV-38000L / 8163G)

The FuelTainer Versatile tank is a class leading innovative double wall tank design that provides safe and secure storage dispensing of fuel & fluids. The tank easily fitted with various pumps , reels , flow meters , filters & dispensing systems



Specifications

	Metric	US	Imperial
Capacity	37250 Litres	9840 Gallons	8194 Gallons
Length	6058 mm	238"	238"
Width	2438 mm	95 15/16"	95 15/16"
Height	2896 mm	114"	114"
Outer Tank Thickness	6 mm	3/16"	3/16"
Inner Tank Thickness	6 mm	3/16"	3/16"
Weight, Tare	7720 kg	17019 lbs, 11oz	17019 lbs, 11oz
Weight, Laden	37800 kg	83334 lbs, 12oz	83334 lbs, 12oz
Safe Fuel Fill Level	27250 Litres	9840 Gallons	8194 Gallons

Approvals and Certifications

UK & Europe

- ✓ Lifting When Empty
- ✓ CSC
- ✓ ISO688
- ✓ AS1940
- ✓ UL 142
- ✓ AS1682 CAT.3
- ULC S601

Optional

- ✓ BS799

USA & Canada

- ✓ CSC
- ✓ ISO688
- ✓ Lifting When Empty
- ✓ UL 142
- ✓ ULC S601

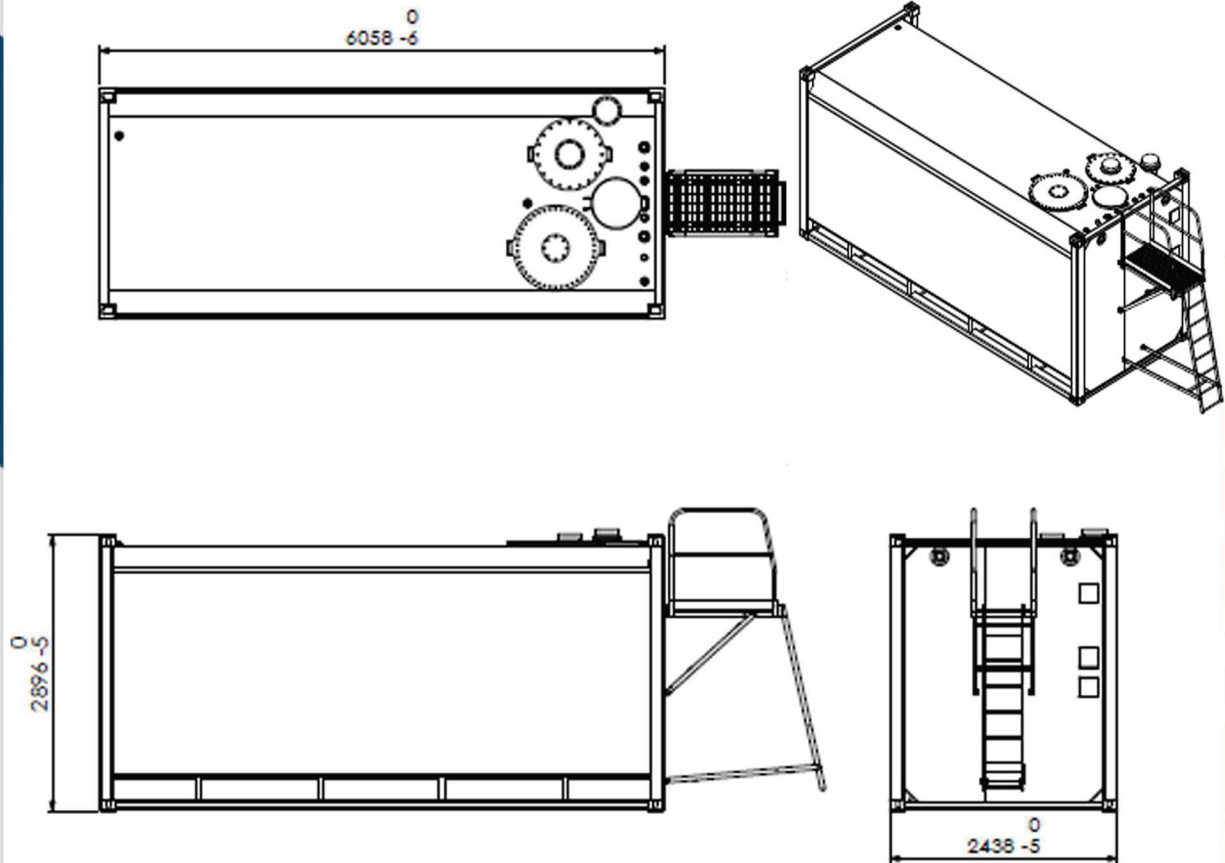

3" Incoming pipe work, male camlock, cap, 80mm fire safe ball valve, wafer check valve, mechanical overfill prevention valve. 3" Discharge pipe work with foot valve.



Male Camlock with cap, 80mm fire safe ball valve.

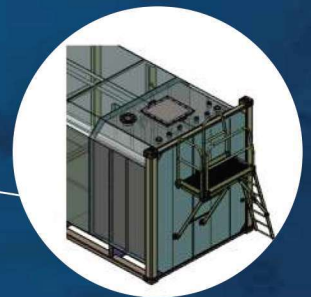

Collapsible ladder and walkway design for ease while in transit.

FUELTAINER

VERSATILE

Model (FTV-68000L /18234G)

The FuelTainer Versatile tank is a class leading innovative double wall tank design that provides safe and secure storage dispensing of fuel & fluids. The tank easily fitted with various pumps , reels , flow meters , filters & dispensing systems

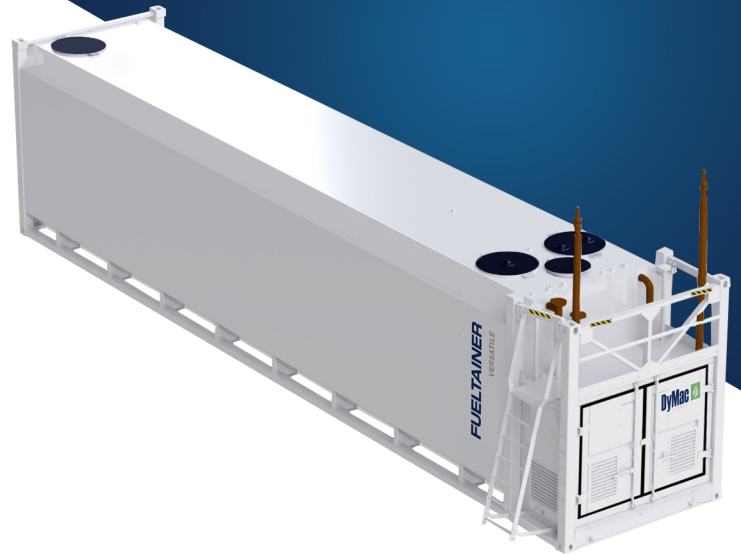

Specifications

	Metric	US	Imperial
Capacity	68023 Litres	18234 Gallons	15183 Gallons
Length	12192 mm	480"	480"
Width	2438 mm	95 15/16"	95 15/16"
Height	2896 mm	114"	114"
Outer Tank Thickness	6 mm	3/16"	3/16"
Inner Tank Thickness	6 mm	3/16"	3/16"
Weight, Tare	13538 kg	29846 lbs, 3oz	29846 lbs, 3oz
Weight, Laden	69274 kg	152723 lbs, 0oz	152723 lbs, 0oz
Safe Fuel Fill Level	65750 Litres	17369 Gallons	14463 Gallons

Approvals and Certifications

UK & Europe

- ✓ Lifting When Empty
- ✓ CSC
- ✓ ISO688
- ✓ AS1940
- ✓ UL 142
- ✓ AS1682 CAT.3
- ULC S601

Optional

- ✓ BS799

USA & Canada

- ✓ CSC
- ✓ ISO688
- ✓ Lifting When Empty
- ✓ UL 142
- ✓ ULC S601

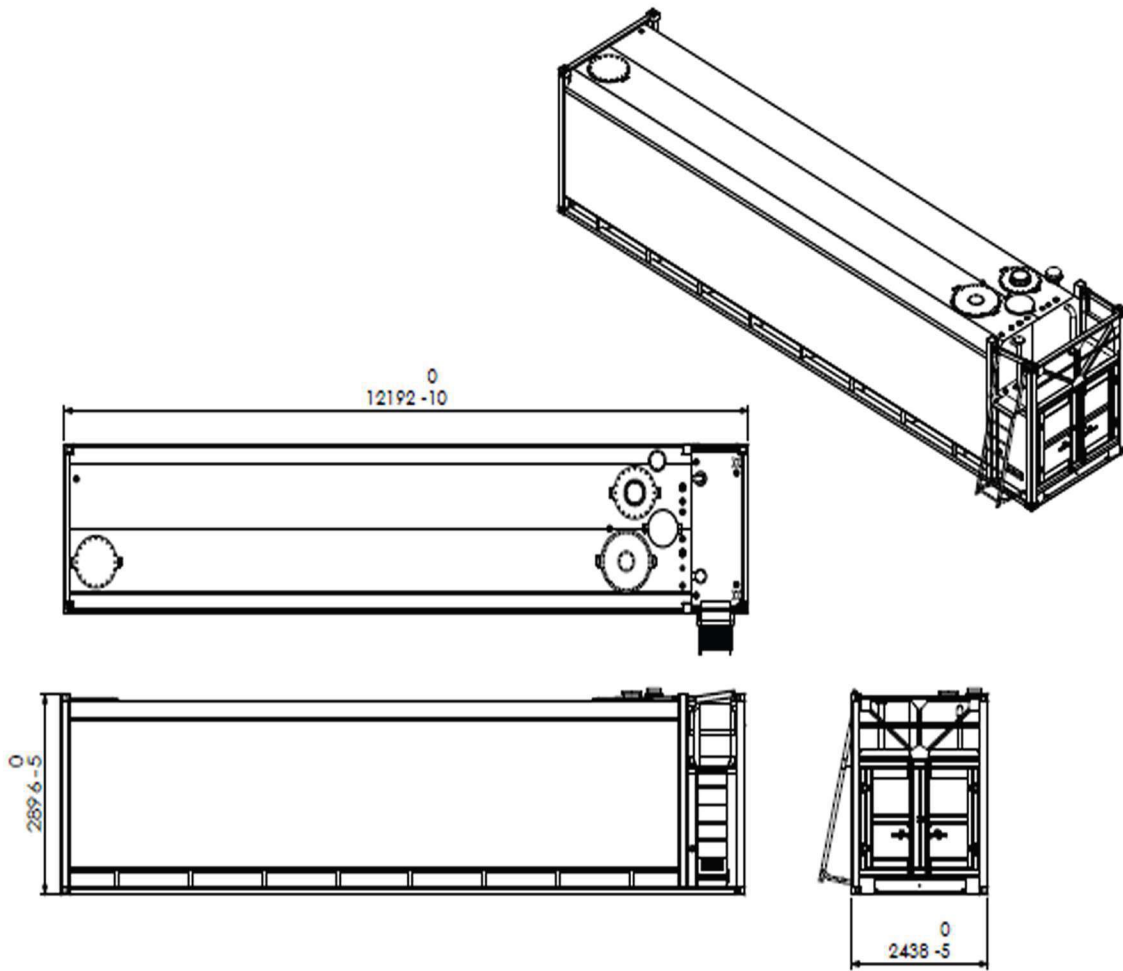

The FuelTainer versatile tank features a large equipment compartment area designed to host various Pumps, Dispensing Stations and STPs brands. Examples shown in the exploded images below.



Fuel Management console Panel



Diesel dispensing station with Dispensing nozzle80LPM



Red Jacket Submersible Turbine Pump



Blackmer GNX Series pumps provides flow capacities from 7 to 500 gpm (25 to 1,893 L/min)

FUELTAINER

VERSATILE

Model (FTV-75000L /19813G)

The FuelTainer Versatile tank is a class leading innovative double wall tank design that provides safe and secure storage dispensing of fuel & fluids. The tank easily fitted with various pumps , reels , flow meters , filters & dispensing systems

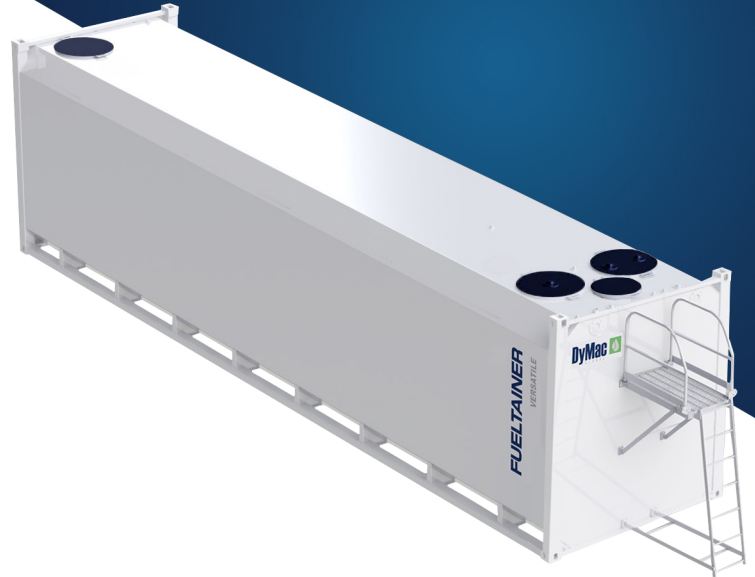

Specifications

	Metric	US	Imperial
Capacity	75370 Litres	19911 Gallons	15183 Gallons
Length	12192 mm	480"	480"
Width	2438 mm	95 15/16"	95 15/16"
Height	2896 mm	114"	114"
Outer Tank Thickness	6 mm	3/16"	3/16"
Inner Tank Thickness	6 mm	3/16"	3/16"
Weight, Tare	13542 kg	29854 lbs,16oz	29854 lbs, 16oz
Weight, Laden	74043 kg	163236 lbs, 14oz	163236 lbs, 14oz
Safe Fuel Fill Level	73500 Litres	19417 Gallons	16168 Gallons

Approvals and Certifications

UK & Europe

- ✓ Lifting When Empty
- ✓ CSC
- ✓ ISO688
- ✓ AS1940
- ✓ UL 142
- ✓ AS1682 CAT.3
- ULC S601

Optional

- ✓ BS799

USA & Canada

- ✓ CSC
- ✓ ISO688
- ✓ Lifting When Empty
- ✓ UL 142
- ✓ ULC S601

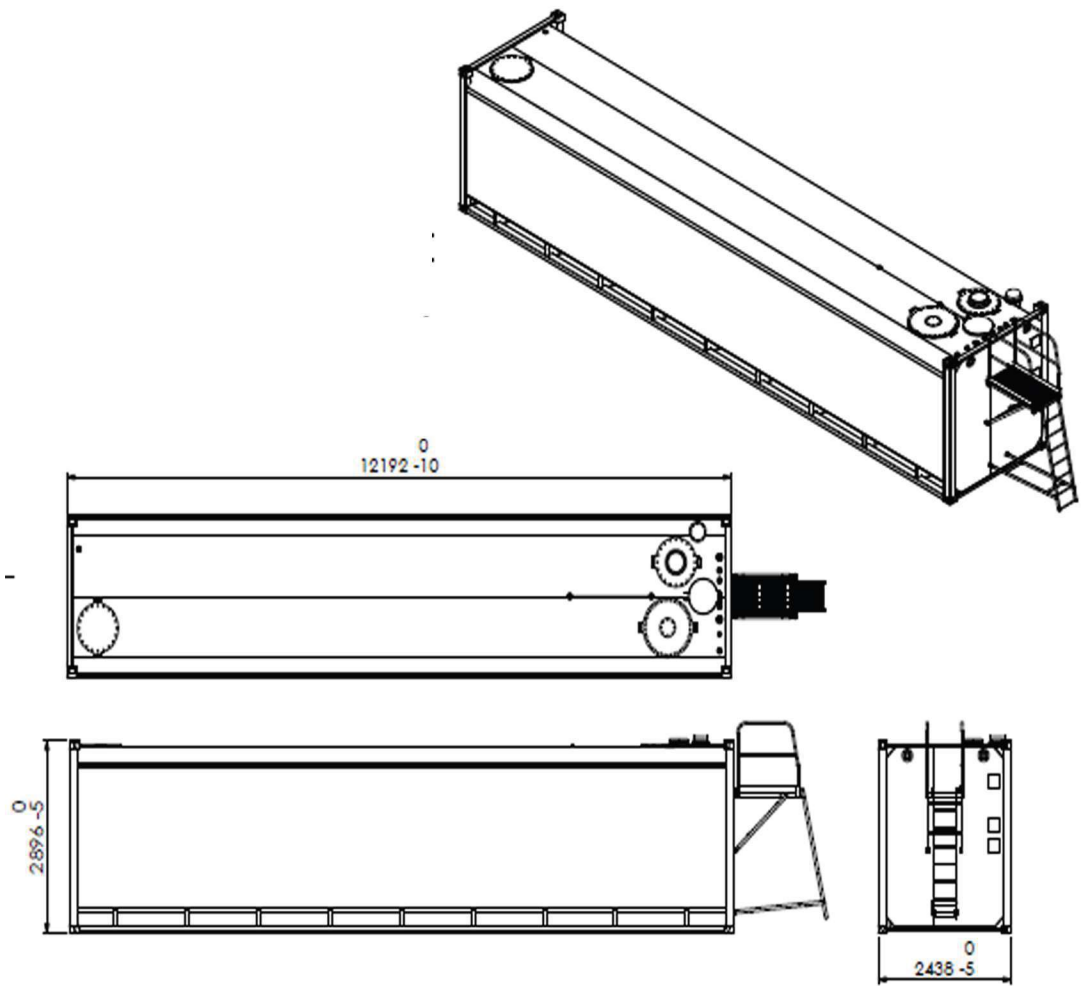

3" Incoming pipe work, male camlock, cap, 80mm fire safe ball valve, wafer check valve, mechanical overfill prevention valve. 3" Discharge pipe work with foot valve.



Male Camlock with cap, 80mm fire safe ball valve.

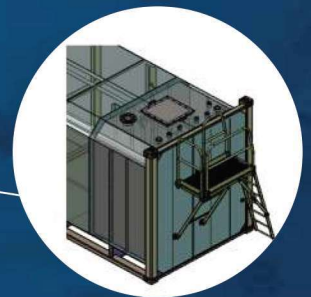

Collapsible ladder and walkway design for ease while in transit.



Fuelling Your Progress

DyMac Global Head Office
E: sales@dymacglobal.com
T: +44 300 303 3353
Kitsmead Lane
Longcross, Chertsey
Surrey KT16 0EF
United Kingdom

DyMac Global India
E: india@dymacglobal.com
T: +91 8243556957
Pam Arcade
3rd floor, Kottara
Ashok Nagar
Mangalore - 575006
India

DyMac Canada
E: canada@dymacglobal.com
T: +1 905 564 3654
Mississauga
Toronto
Canada

DyMac Europe / Ireland
E: europe@dymacglobal.com
T: +353 1 442 0516
Unit 3B, Canal Bank
Hume Avenue
Park West Ind EST
Dublin
Ireland

www.dymacglobal.com