

Falcon

solar light 201



ZERO *Fuel*
Noise
Emissions
Maintenance

DyMac 
UNITED KINGDOM



Enhanced Design Features

Power

The Falcon Solar Light 201 harnesses the sun's power through 3 extendable high grade solar panels that ensure maximum lighting performance and brightness.

Security

The Falcon Solar lighting tower comes complete with galvanized retractable stabilizers for added security when in operation.

Design Quality

The Falcon Solar Light 201 has been manufactured with high grade steel and is powder coat painted to the highest standards and c/w certified high quality electrical components.

Easy Set Up

The Falcon Solar lighting tower comes complete with automatic telescopic mast operated by a push button device conveniently located on the unit.

Our Mission

We design products that harvest clean energy, minimising the impact on the environment.

In line with the UK and European governments commitments of realizing zero net carbon by 2050, we are focused on reducing carbon emissions throughout our business and supply chains by bringing the most innovative and advance products to market in line with progress to a circular economy.



Harvesting Clean Energy / Protecting Our Environment

Features

Falcon Solar Light 201 is a compact and powerful portable solar lighting tower. The FSL-201 features 4 LED lamps which provides a brighter and more environmentally-friendly lighting system.

The innovative solar panel and trailer design make the FSL-201 easy to transport and set up without taking up valuable space.



Superior Features



Manually extendable & adjustable Solar PV panels designed to maximise the sun's rays during daylight hours



4 x 100W tiltable LED lighting system with 7m electrically extendable mast and 360° rotation head providing 2400 sq.m of lighting coverage



Intelligently designed electrical control panel display providing multiple user optimisation options

SECTORS



CONSTRUCTION



SPECIAL EVENTS



OIL, GAS &
MINING



HARD TO REACH
AREAS



MILITARY

Advanced Security Features

WiFi Dual Light Source Smart Trackball Camera

- The Falcon Solar Light 201 also comes with WiFi operated CCTV security camera which comes with 3D humanoid detection to realize intelligent tracking .
- Support dual light function, move frame measurement trigger to turn on white light.
- Support motion detection alarm and push of abnormal pictures found.
- Built-in microphone and speaker function, which can realize two-way voice intercom.
- Support 18 times optical zoom, support full synchronization focus.
- Support IP66 waterproof function, applicable to a wider range of scenarios.
- Support 256 preset position functions, easily cope with various scenarios.
- TF card supports up to 128G, and supports cloud storage function.
- Support AP hotspot function, which can realize direct device connection and disconnection monitoring.
- Intelligent voice prompt, one-key connection, simple operation.
- External 5db, WiFi dual antenna, stable information, coordinated and beautiful appearance.
- Metal front face, suitable for a variety of application scenarios



Applicable Scenarios

Warehouses, Underground Parking Lots, Bars, Hotel, Office Area, Bank, Supermarket, Concerts, Etc.



360° ROTATABLE CAMERA



SUPPORTS 18x OPTICAL ZOOM



IP66 WATERPROOF FUNCTION



3D HUMANOID DETECTION



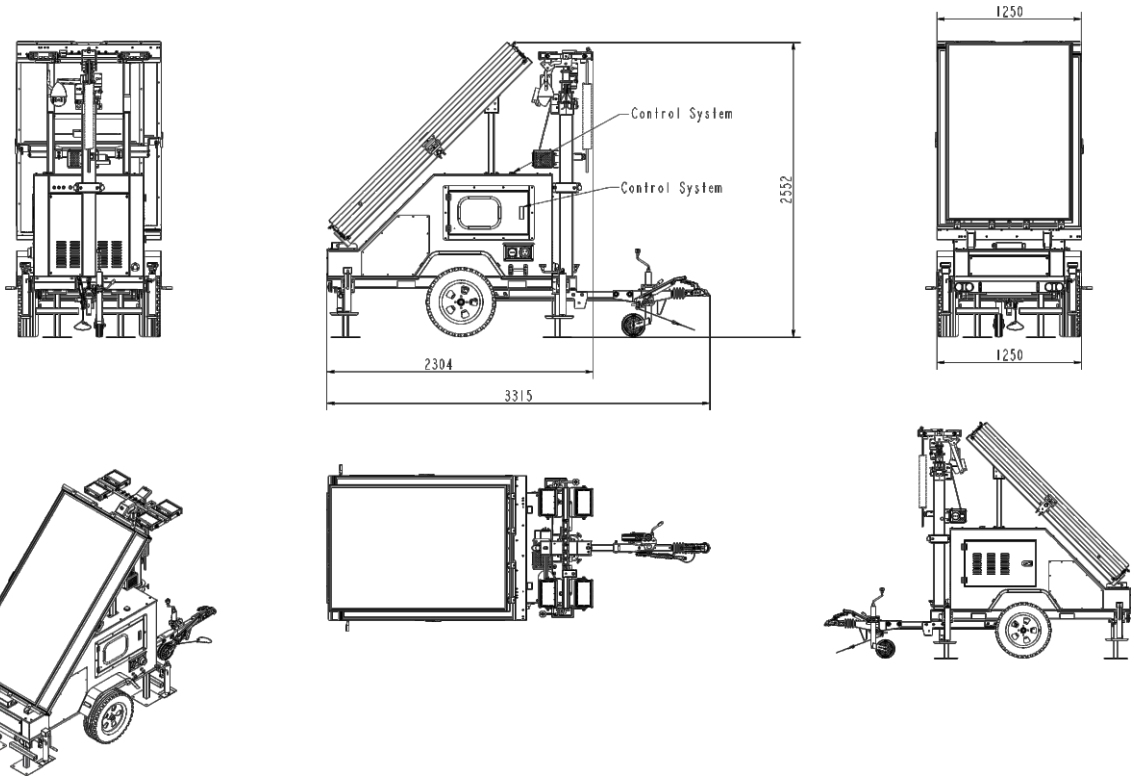

Dimensions

Length (L) (mm)	2300	Weight (Kg)	774
Width (W) (mm)	1250	Loading capacity in 40 HQ (units)	09
Height (H) (mm)	2550		



2400 SQM



0% EMISSIONS



0% NOISE



0% FUEL



**RUN TIME
365 NIGHTS**



09 PER TRUCK

Harvesting Clean Energy / Protecting Our Environment

Falcon

solar light 201

Model (FSL-201)



Solar Charging Controller

Model	UP 2000 - HM6022
Max. Battery Charging Current	60 A
Rated Voltage	24 V
Max. PV Input Power	2500 W
Max. Output Efficiency	99.5%
Utility Input Voltage	176VAC~264VAC (Default); 90VAC~280VAC (Programmable)
Utility Input Frequency	40~65Hz
Max. Utility Charge Current	60A
Continuous Output Power (Inverter)	2000W
Output Voltage Range	220VAC (-6%~+3%); 230VAC (-10%~+3%)
Output Frequency Range	50/60Hz±0.2%
Max. Output Efficiency	93%
Protection Class	IP30
Quantity	1pcs

Solar Panel

Maximum Power (Pmax)	550 W
Maximum Power Voltage (Vmp)	41.96 V
Maximum Power Current (Imp)	13.11 A
Power Tolerance	0/+5W
Lifting Angle	45°
Extending Type	Sliding
Extending area	6.85m ²

Battery Bank

Type	Lithium-Ion battery
Model	2 x 100AH 25.6V
Voltage	25.6 (One battery)
Maximum Charging Current	100A
Quantity	1 pcs

Trailer

Model	AL-KO B750 (On Road)
Loading Capacity	750 Kg
Drawing Bar	Ball Type
Pulling Speed	≤ 80km/h

Mast

Model	LHSL - 1000A1
Maximum Lifting Height	7.5m
Mast type	Electric

LED Lamp

Input Voltage	DC 24V
LED Power	100W (One Lamp)
Light Bean Angle	60°
LED Luminous Efficiency	160lm/w
Correlated Color Temperature	3000 - 5700K
Protection Class	IP67

Standby Gasoline Generator

Maximum Power	1.5 kW
Rate Voltage	AC 230V

Others

Battery Charger	AC 220V-240V 20A
Inverter	500W (DC 24V-AC 230V, 50/60Hz)
Web Camera	HD-IP Wi-Fi Operated
4G Router	Provide 4G wireless network



Harvesting Clean Energy / Protecting Our Environment

*Long Lane Farm, Ascot Road, Holyport, Maidenhead,
Berkshire, United Kingdom, SL6 3LG*

T: +44 300 303 3353 E: sales@dymacuk.com

www.dymacuk.com