



The TransFueler Highway range has been designed to enable safe storage and transportation of diesel fuel.



Available Sizes

- ✓ TF-HW 8500L/2245G
- ✓ TF-HW 19500L/5151G

TransFueler
Highway



Enhanced Design Features

Transportable Design

The TransFueler Highway tank is a fully transportable, 110% self bunded fuel storage container that was designed for bulk fuel transfer and emergency fuel supply.

Inner Tank Design

Designed with a cylindrical inner tank in accordance with transport regulations. Built to ISO container dimensions, the TransFueler Highway allows for simplified shipping by road, rail or sea.

Stacking & Racking

ISO container design allows stacking up to 6 high when full reducing your storage space required.

Dispensing & Accessibility

The TransFueler Highway tank range comes equipped with a spacious equipment chamber which engages a bespoke universal bracket system

Equipment Cabinet

Lockable equipment cabinet that secures all ports and fittings, as well as captures all spills and drips. Secure hose access enables fuelling while cabinet is locked.



Design Innovation

Take a look inside

The TransFueller Highway tank is a fully transportable, 110% self-bunded fuel storage container that was designed for bulk fuel transfer and emergency fuel supply.

Designed with a cylindrical inner tank in accordance with transport regulations. Lockable equipment cabinet that secures all ports and fittings, as well as captures all spills and drips. Secure hose access enables fuelling while cabinet is locked.



Standard Features



The tank has been designed with multiple feed and return pipes which are centrally positioned.



The bundled, two-tier system protects against spillage if a breach of the Inner tank occurs.



Designed with ISO corners for ease of lifting and maneuverability.

TransFueler

Highway

Model (TF-HW-8500L/2245G)

The TransFueler Highway tank range has been designed for transporting fuel on all major freeways when full. It is ideal for quick response refuelling projects.



Specifications

	Metric	US	Imperial
Capacity	8200 Litres	2166 Gallons	1804 Gallons
Length	2991 mm	117 12/16"	117 12/16"
Width	2438 mm	95 15/16"	95 15/16"
Height	2438 mm	95 15/16"	95 15/16"
Outer Tank Thickness	3 mm	1/8"	1/8"
Inner Tank Thickness	6 mm	1/4"	1/4"
Weight, Tare	4400 kg	9700 lbs, 5oz	9700 lbs, 5oz
Weight, Laden	11021 kg	24297 lbs, 2oz	24297 lbs, 2oz
Safe Fuel Fill Level	7790 Litres	2058 Gallons	1714 Gallons

Approvals and Certifications

UK & Europe

- ✓ ADR
- ✓ 49CFR (US DOT)
- ✓ UN T9 Portable Tank
- ✓ CSC
- ✓ ISO1496/3
- ✓ RID
- ✓ TIR
- ✓ IMDG

USA & Canada

- ✓ ADR
- ✓ 49CFR (US DOT)
- ✓ UN T9 Portable Tank
- ✓ CSC
- ✓ ISO1496/3
- ✓ RID
- ✓ TIR
- ✓ IMDG
- ✓ UL142

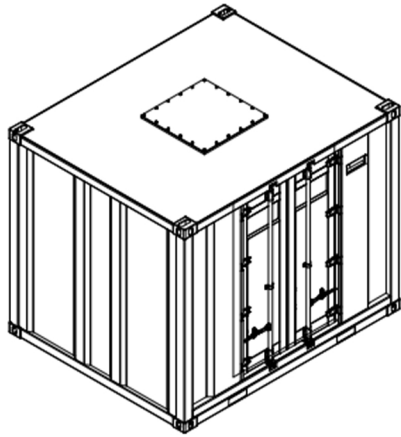

ISOMETRIC VIEW

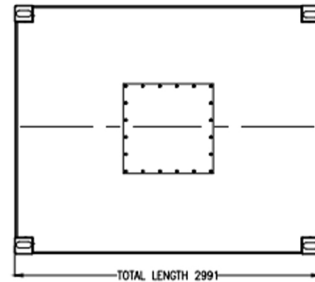

TOTAL LENGTH 2991
PLAN VIEW

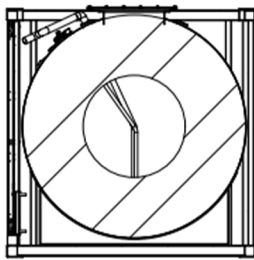

SECTION A-A

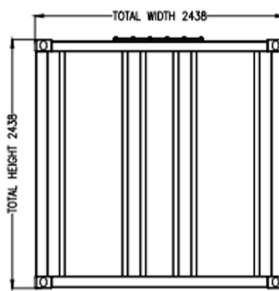

FRONT VIEW

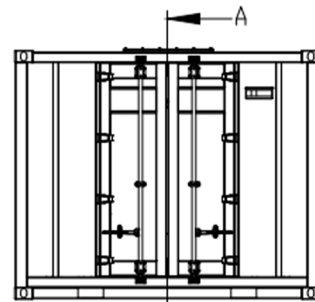

ELEVATION VIEW

ACCESS HATCH

Easy access to inner tank for routine maintenance and cleaning. Letterbox-style ports to enable continuous fuelling while cabinet is locked.

CYLINDRICAL INNER TANK

Cylindrical inner tank to comply with transport regulations. Built-in, weather proof bund.

ISO CONTAINER DIMENSIONS

Built to ISO container dimensions to allow simplified shipping by road, rail, or sea.

FORKLIFT POCKETS

The use of forklift pockets enables easy mobility and maneuverability.

EQUIPMENT CABINET

Lockable equipment cabinet that secures all parts and fittings, as well as captures all spills and drips.

STACKABLE

Container design allows stacking up to six high when full, reducing your storage space required. Corner twist locks for ease of handling and transport.

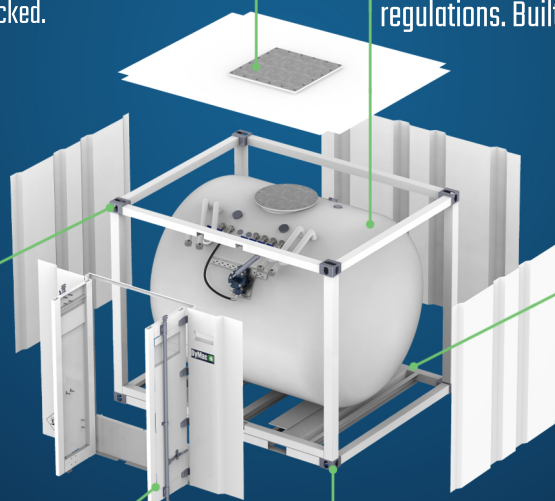

TransFueler

Highway

Model (TF-HW-19500L/5151G)



The TransFueler Highway tank range has been designed for transporting fuel on all major freeways when full. It is ideal for quick response refuelling projects.

Specifications

	Metric	US	Imperial
Capacity	19750 Litres	5217 Gallons	4344 Gallons
Length	6058 mm	238"	238"
Width	2438 mm	95 15/16"	95 15/16"
Height	2438 mm	95 15/16"	95 15/16"
Outer Tank Thickness	3 mm	1/8"	1/8"
Inner Tank Thickness	6 mm	1/4"	1/4"
Weight, Tare	6500 kg	14330 lbs, 1oz	14330 lbs, 1oz
Weight, Laden	23500 kg	51808 lbs, 10oz	51808 lbs, 10oz
Safe Fuel Fill Level	18687 Litres	4937 Gallons	4111 Gallons

Approvals and Certifications

UK & Europe

- ✓ ADR
- ✓ 49CFR (US DOT)
- ✓ UN T9 Portable Tank
- ✓ CSC
- ✓ ISO1496/3
- ✓ RID
- ✓ TIR
- ✓ IMDG

USA & Canada

- ✓ ADR
- ✓ 49CFR (US DOT)
- ✓ UN T9 Portable Tank
- ✓ CSC
- ✓ ISO1496/3
- ✓ RID
- ✓ TIR
- ✓ IMDG
- ✓ UL142

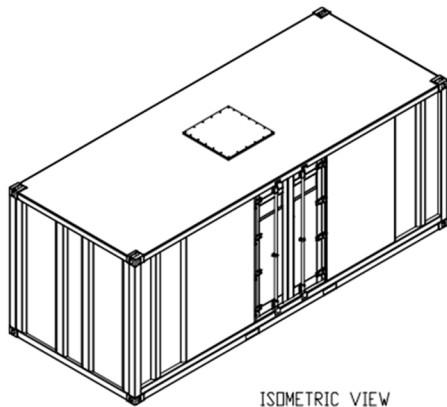

ISOMETRIC VIEW

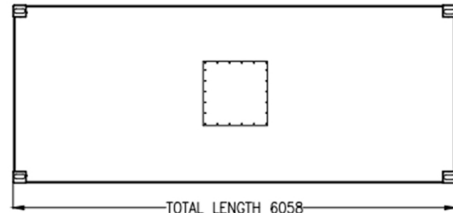

TOTAL LENGTH 6058

PLAN VIEW

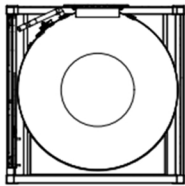

SECTION A-A

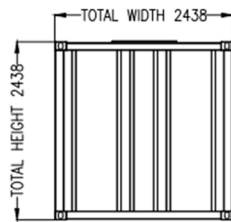

TOTAL WIDTH 2438

TOTAL HEIGHT 2438

FRONT VIEW

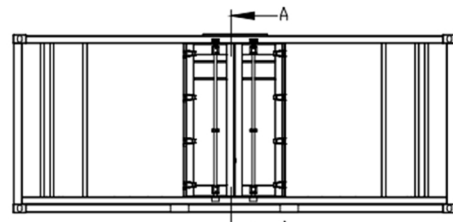

ELEVATION VIEW

ACCESS HATCH

Easy access to inner tank for routine maintenance and cleaning. Letterbox-style ports to enable continuous fuelling while cabinet is locked.

CYLINDRICAL INNER TANK

Cylindrical inner tank to comply with transport regulations. Built-in, weather proof bund.

ISO CONTAINER DIMENSIONS

Built to ISO container dimensions to allow simplified shipping by road, rail, or sea.

FORKLIFT POCKETS

The use of forklift pockets enables easy mobility and maneuverability.

EQUIPMENT CABINET

Lockable equipment cabinet that secures all ports and fittings, as well as captures all spills and drips.

STACKABLE

Container design allows stacking up to six high when full, reducing your storage space required. Corner twist locks for ease of handling and transport.

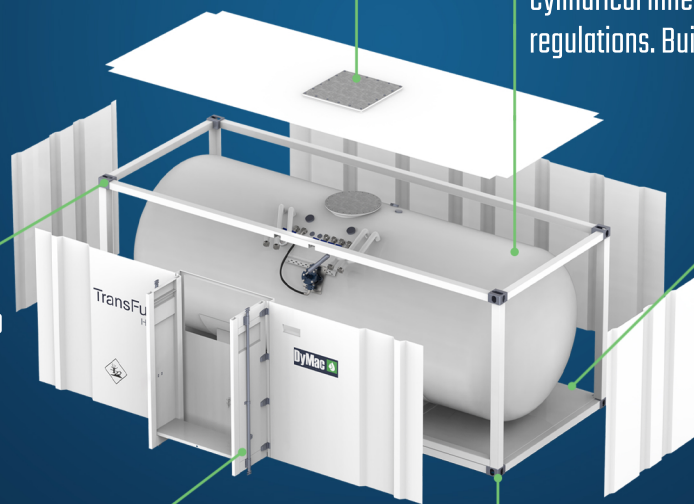



Fuelling Your Progress

DyMac Global LTD / DYMAC UK

E: sales@dymacglobal.com

T: +44 300 303 3353

LONG LANE FARM
ASCOT ROAD, HOLYPORT
MAIDENHEAD
BERKSHIRE SL6 3LG
UNITED KINGDOM

DYMAC INDIA PVT

E: india@dymacglobal.com

T: +918243559370

FIRST FLOOR,
AJANTA BUSINESS CENTER,
BEJAI KAPIKAD ROAD,
MANGALORE D.K,
KARNATAKA - 575003,
INDIA

DYMAC CANADA INC

E: canada@dymacglobal.com

T: +1905 564 3654

MISSISSAUGA
TORONTO
CANADA

DYMAC IRELAND

E: ireland@dymacglobal.com

T: +353 1 442 0516

BROWNSTOWN ROAD
COMMONS, NEWCASTLE,
CO. DUBLIN,
D22 Y2F2
IRELAND

DYMAC USA INC

E: usa@dymacglobal.com

T: +1 905 564 3654

3028 GREENMOUNT AVE #2038
BALTIMORE, MD
UNITED STATES 21218