



UCMED Hospital - Cebu City



HERMETIC AUTO-DOOR

DAH -150



FUNCTION:

- The door has a smooth and flat finish. Attracts virtually no dirt and is extremely easy to clean.
- The rail system guarantees hermetic closure.
- When closed, the door positively seals against the floor preventing dust from blowing up.
- Micro-computer controller.
- Two-way magic eye ensure security

TECHNICAL DATA:

Door Configuration	: Single Leaf, Double Leaf
Limited Weight	: ≤1 x 150 kgs., ≤ 2 x 100kgs.
Max. Opening	: 2000mm width x 2500mm height
Power Supply	: AC 220V± 10%, 50 - 60 HZ
Power Consumption	: 100W
Opening Speed	: 200 - 500mm /sec. (adjustable)
Closing Speed	: 200 - 500mm/ sec. (adjustable)
Opening Time	: 3 - 75 (adjustable)
Hold Open Time	: 0 - 9sec(s). (adjustable)
Manual Force	: <100N
Opening Control	: foot inductive switch / touchless switch Infrared sensor / card or biometric reader
Closing Control	: Auto / Manual

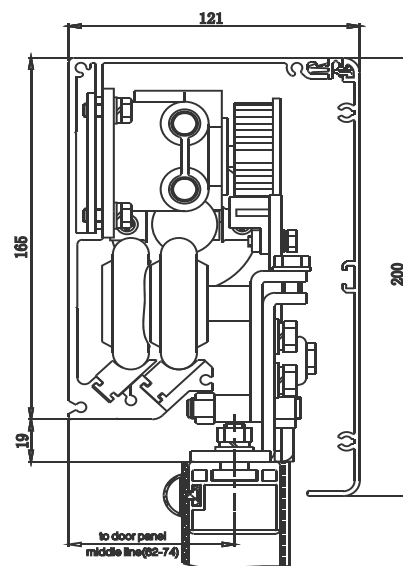

PLACES OF APPLICATION:

- Hospital / Clinic / Operating Rooms
- X-Ray Rooms
- Recovery Areas
- Pharmaceutical Facilities
- Sound Insulation Rooms
- Clean Rooms

MANUFACTURED EXCLUSIVELY FOR CARGEM MANAGEMENT CORPORATION AND CMC NIVRA Industries Corp.

HEAD OFFICE:

P & E Bldg. no. 12 United
cor. 1st Sts., Bo. Kapitolyo
Pasig City 1603
Tel. : (+632) 631-9520
(+632) 634-4746
Fax : (+632) 631-9512

CEBU BRANCH OFFICE:

Unit 3 Salustina Bldg.
M. L. Quezon Ave., Casuntingan
Mandaue City, Cebu City 6014
Tel. : (+032) 511-9774
Fax : (+032) 236-9907

DAVAO BRANCH OFFICE

Door 1, Usman Bldg.
Diversion Road, Buhangin
Davao City 8000, PH
Tel. : (+082) 224-3426

ILOILO BRANCH

Tydyco Commercial Complex
Kahilwayan Ave.,
Santa Barbara, Iloilo City
5002 PH
Tel. : (+032) 511-9774
: (+63) 917-7103628

CAGAYAN DE ORO BRANCH

Unit 10 Kauswagan Arcade
Cagayan de Oro City 9000
Tel. : (+632) 088-881-3947

Sales, Assembly, Installation, Commissioning, Maintenance and service after Sales
Exclusively by CARGEM MANAGEMENT Corp.