

# Max Okst

CALARTS SCHOOL OF THEATER  
PRESENTS

TICKETS AVAILABLE AT  
theaterfest.calarts.edu

APRIL  
27-29, 2023  
8PM  
29, 2023  
2PM

EVERYBODY

WRITTEN BY  
BRANDEN  
JACOBS-JENKINS

DIRECTED BY DAMIAN D. LEWIS

E407  
24700 MCBEAN  
PARKWAY,  
VALENCIA, CA  
91355

## *Everybody*

Written by Branden Jacobs-Jenkins

E407 | CalArts | 2022

Director - Damian D. Lewis

Scenic Designer - Sally Cho

Costume Designer - Karen Ayala-Gaytan

**Lighting Designer - Max Okst**

Asst. Lighting Designer - Evan Brownell

Video Designer - Grace Hlavacek

Sound Designer - Steve Cobilich

Producer - Park Lytle

# Max Okst

## Design Statement



*Everybody* is a radical retelling of *Everyman*, and follows the journey of a human preparing for the grave. It is the story of how we all might face judgment when it's time to answer the question: "How did you choose to live your life?". The meta-theatrical experience delves into the discovery of body image, race, friendship, and social responsibilities. As *Everybody* is preparing to die, they learn that the only thing you have in life and death is yourself. We wanted the audience to leave feeling empowered to be kind to themselves and others with the time we are given.

My lighting goals for the production were to create 3 distinct spaces to delineate the three types of scenes in the play; external emotings, internal thought, and *Everybody's* deathbed. All of these scenes exist in the theatre, but also emulate that of a television studio. The director, Damian Lewis, wanted to create a space for heightened emotion and archetypal characters.



To achieve this, I developed a plot that juxtaposed harsh, vertical, overhead "studio" lighting with horizontal beams to separate *Everybody's* internal thoughts from their external emotings with Friendship, Family, & Stuff. In collaboration with the scenic designer, I was able to incorporate equipment behind the set, in order to break apart the theatre and the scenic structures when *Everybody's* grave was revealed. We wanted to ground the idea that *Everybody* was dying in this theatre, directly in front of us.

# Max Okst

# Production Photos



# Max Okst

## Production Photos

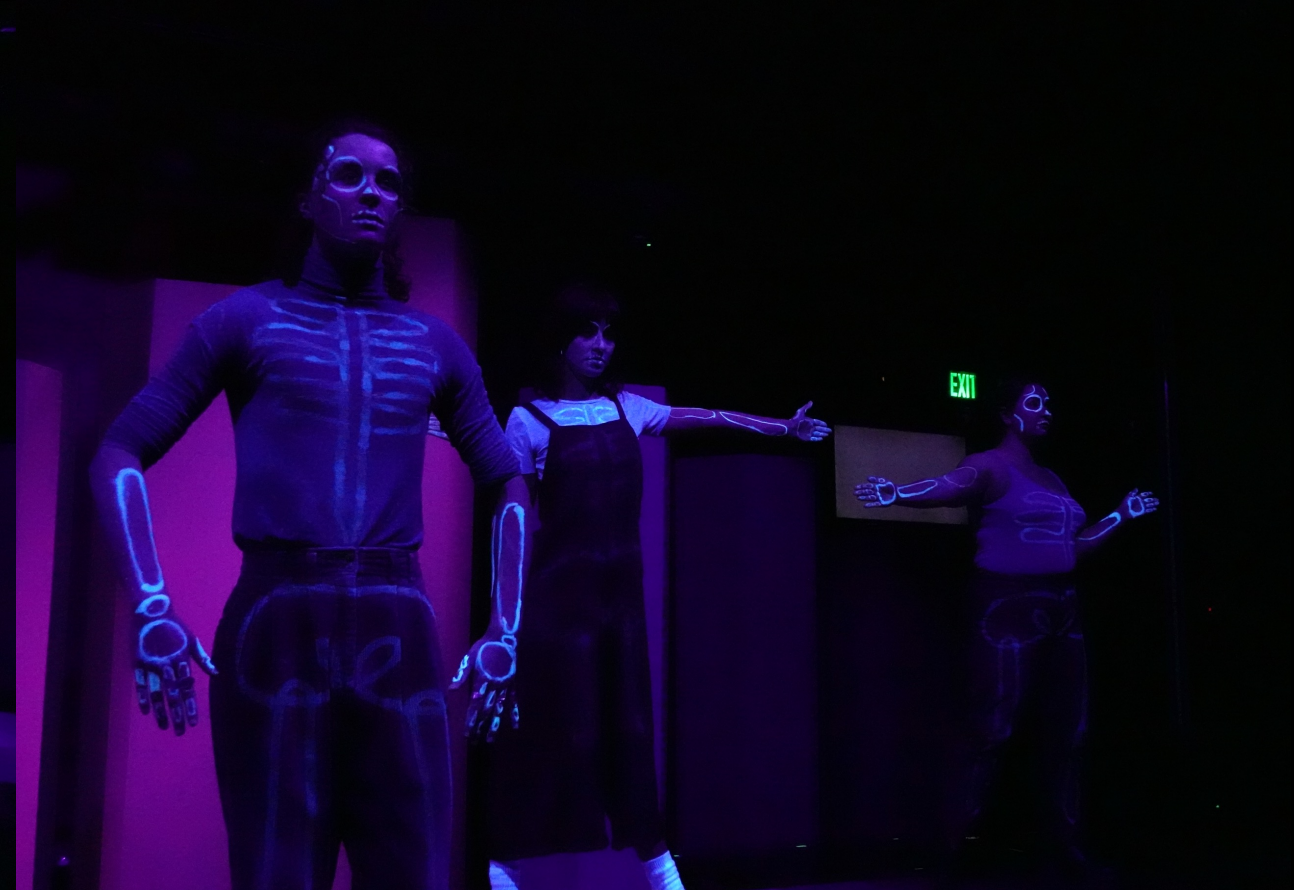

# Max Okst

## Production Photos



Cool  
&  
Unnatural



Instruments as a  
visual

Soft

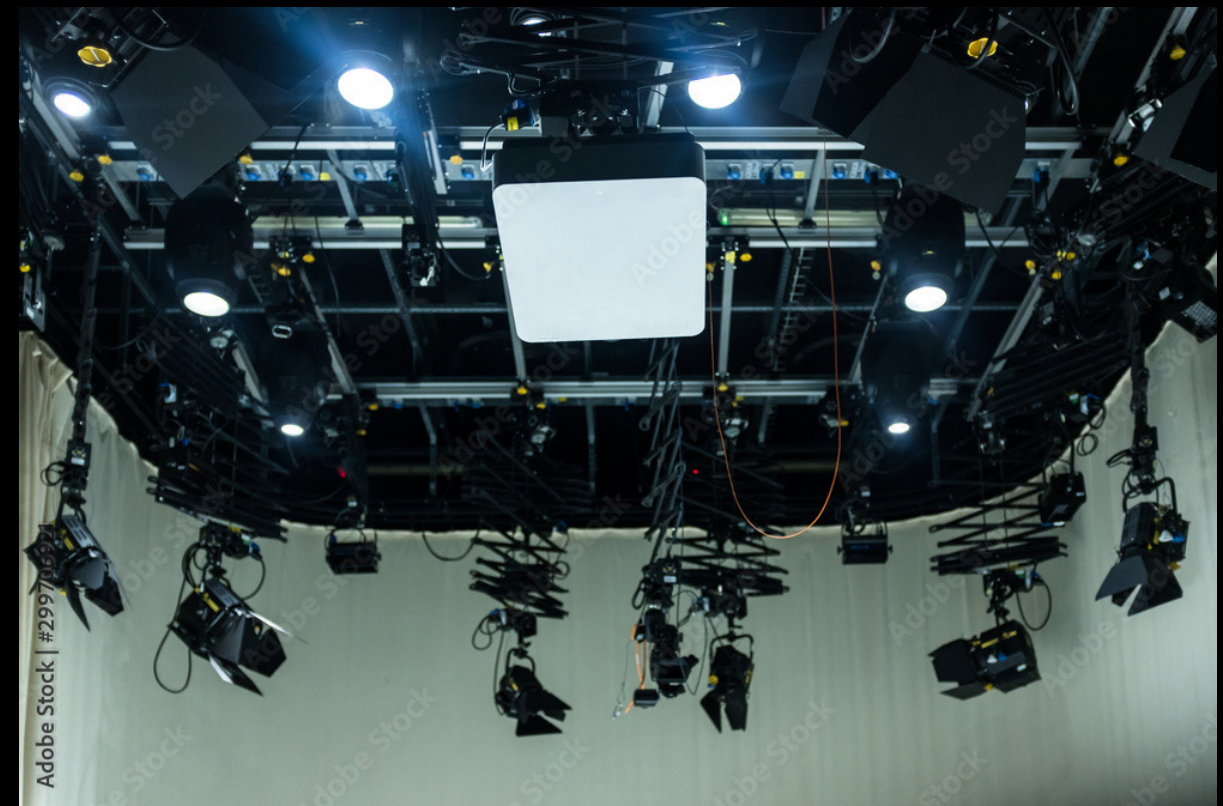

Television Set

Visual  
Weight

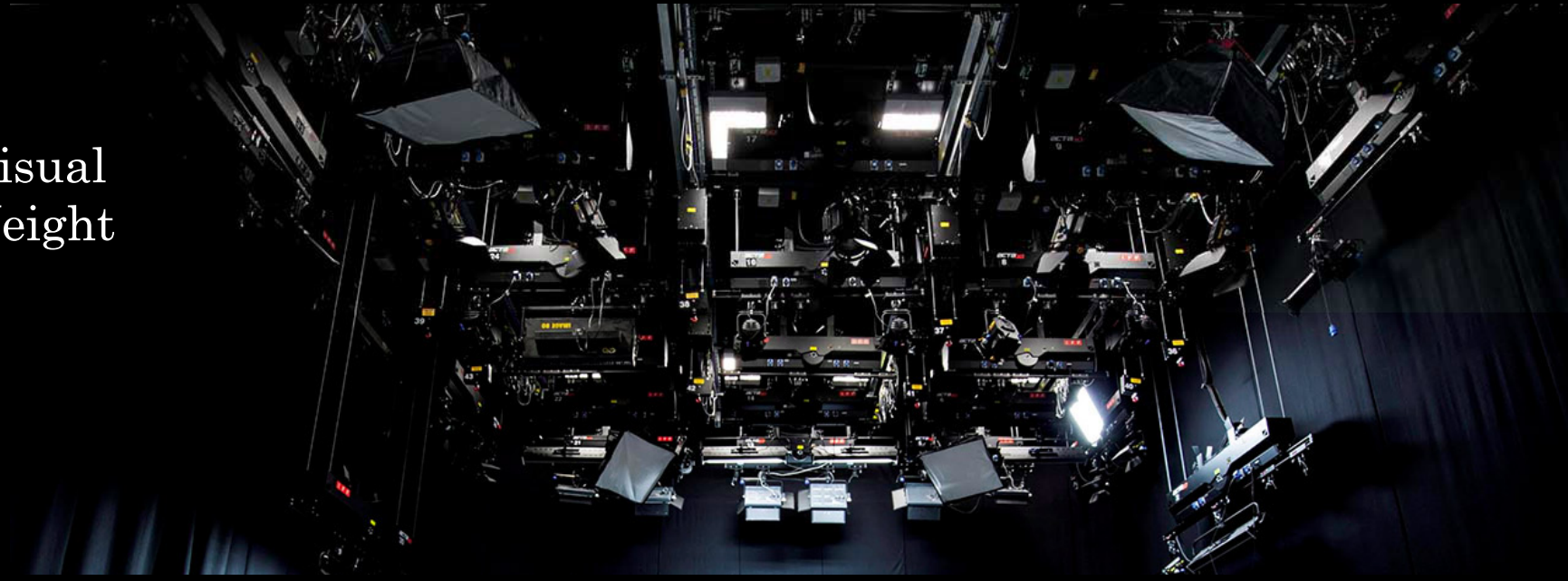

Low Equipment



Prominent



Television Set

Zoom In



Confine

Internal Thought



Soft Glow



Sickly



Internal Thought

Vibrant



UV Paint



UV Clothing

La Danse Macabre

From Below



Seeing Through



Grave Reveal



Reveal Cracks | Harsh

Embrace Natural Shadow



Grave Reveal

Shadow as Form



Highlight Wall Textures



Grave Reveal

Push from behind Audience



Envelop Audience

Push Haze | Diffusion

Reveal Grid



Grave Reveal

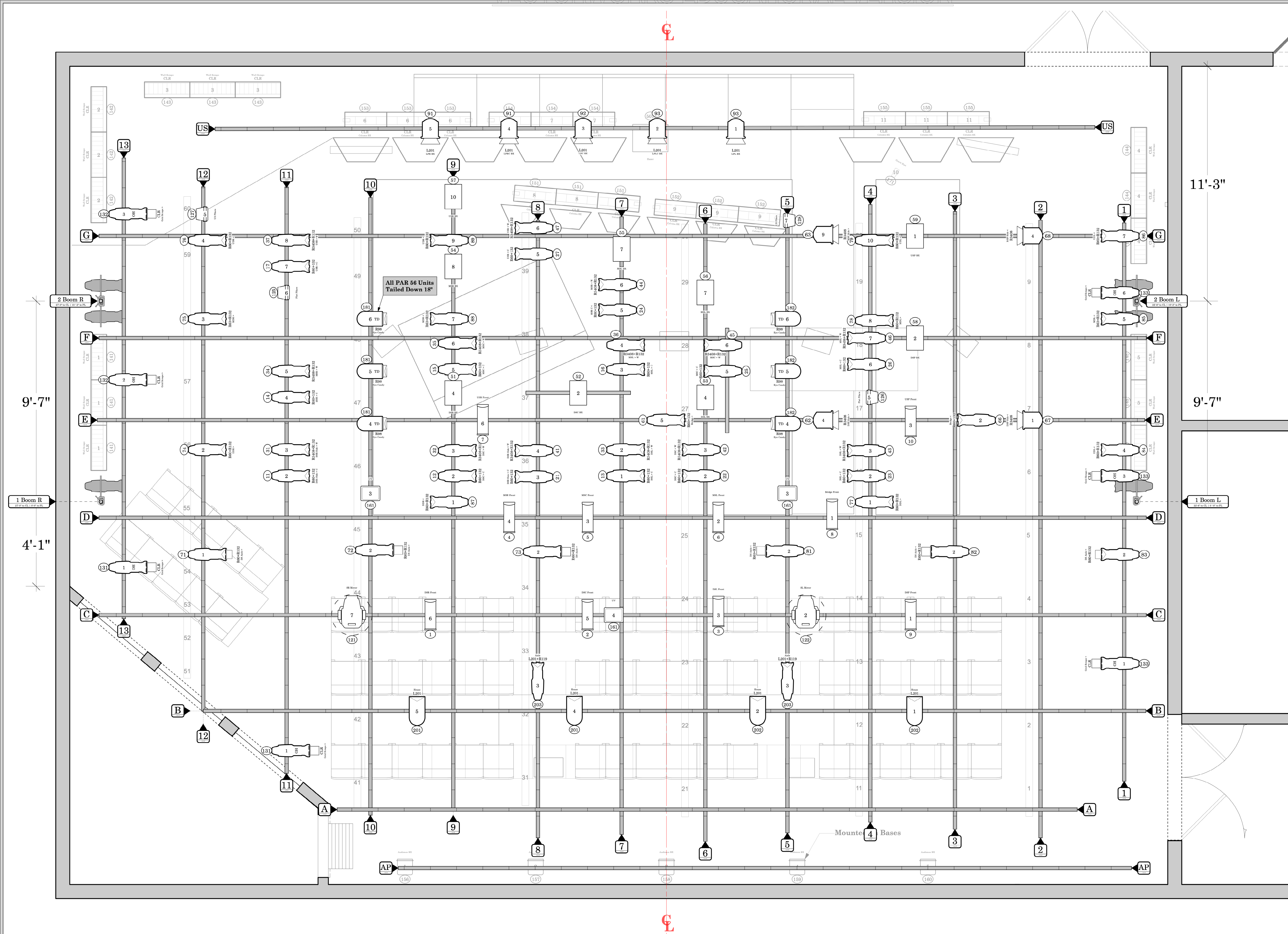

**KEY**

**Conventionals**

- Source 4 28" @ 575w
- Source 4 36" @ 575w
- Source 4 50" @ 575w
- Altman PAR 64 MFL @ 1kw
- Altman Sin Fresnel @ 1kw
- Altman ZS-3 @ 3X750
- Altman 528 3 Circ 6ft @ 12X200

**LED**

- Selecon PL-3 LED @ 360w
- Selecon PLFresnel LED @ 150w
- Selecon PLCYC LED @ 150w
- Chauvet COLORado 1 Tri Tour @ 93w
- COLORdash Accent @ 10w
- LED UV

**Moving Light**

- Chauvet Maverick Mk2 Profile @ 750w

**Haze**

**Accessories**

- 7.5in 4 Leaf Barn Door

**TYPICAL**

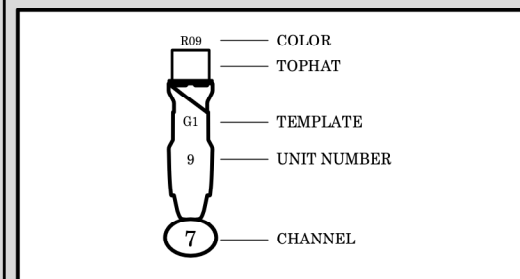

**NOTES**

1. ALL UNITS ON 1" CENTERS UNLESS OTHERWISE NOTED ON PLOT
2. BOOM POSITIONS MARKED AS DISTANCE FROM CL
3. ALL BOOM HEIGHTS MEASURED FROM STAGE DECK (0'-0") TO CLAMP POSITION
4. DROP COLOR, TEMPLATES, AND ACCESSORIES PRIOR TO FOCUS
5. PLEASE HAVE SPARE CUTS OF R119 & R124 AT FOCUS
6. ALL CHANGES/SUBSTITUTIONS MUST BE APPROVED BY DESIGNER

**TEMPLATES**



**REVISIONS**

DATE	CHANGES	WHO
3/21/23	Preliminary	MAO
4/5/23	Final	MAO

**caARTS**

PS4 - E407

**PRODUCER:** Park Lytle  
**DIRECTOR:** Damian D. Lewis  
**SCENIC:** Holly Cho  
**COSTUMES:** Karen Ayala  
**SOUND:** Stephen Cobblech  
**LIGHTING:** Max Okst  
**ASST. LD:** Evan Brownell  
**LX SUP:** Kate DeWall  
**ME:** Bokey King  
**PROGRAM:** Tilda Mingos Seo

**MAX OKST** PLATE  
 (631) 605-8525 | maxokst@gmail.com  
 www.maxokst.com

**LX Plot**  
 1/2" = 1'-0" Arch D  
 1 OF 3

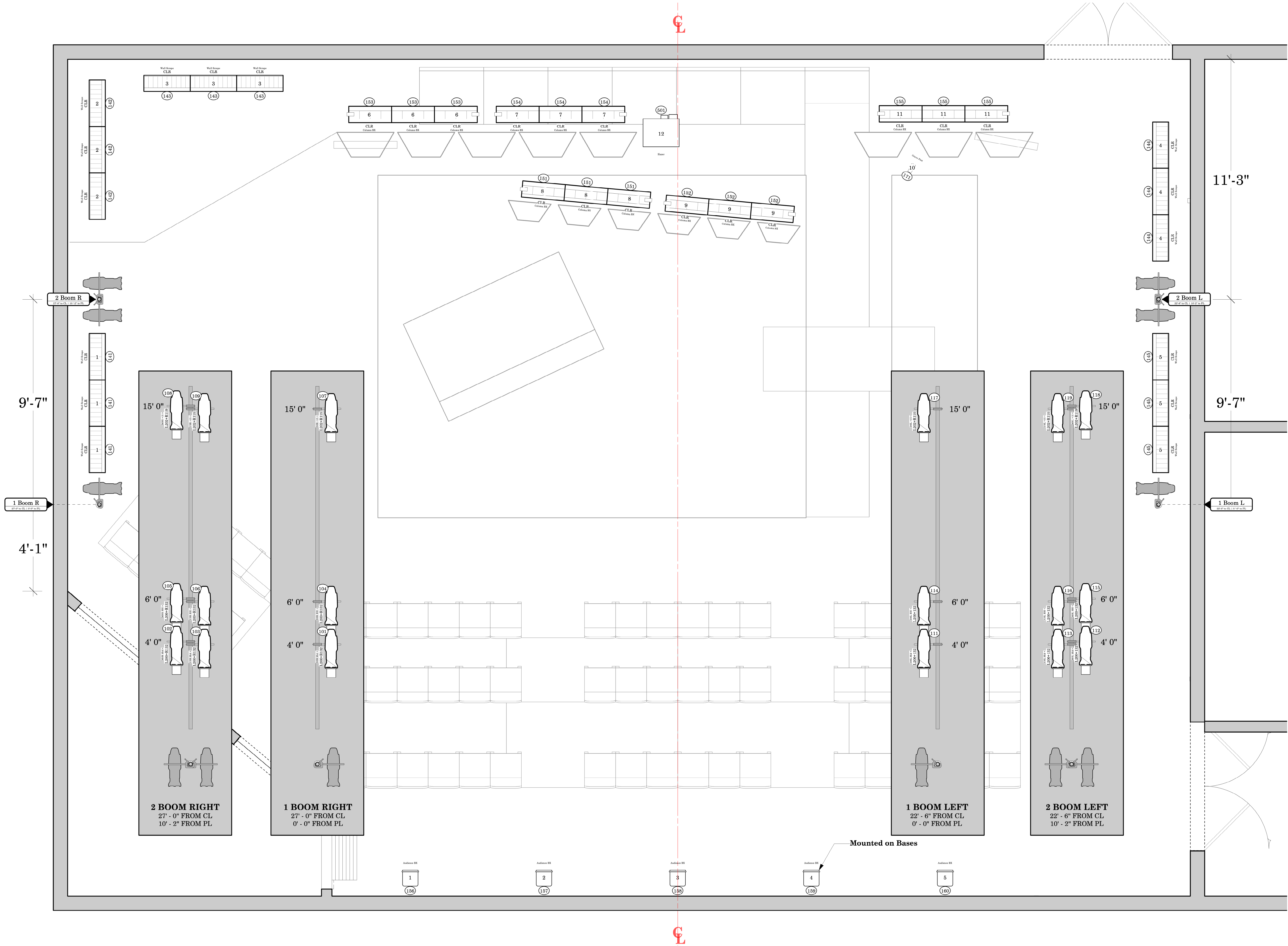

**KEY**

**Conventionals**

- Source 4 28" @ 575w
- Source 4 36" @ 575w
- Source 4 50" @ 575w
- Altman PAR 64 MFL @ 1kw
- Altman Sin Fresnel @ 1kw
- Altman ZS-3 @ 3X750
- Altman 528 3 Circ 6ft @ 12X200

**LED**

- Selecon PL-3 LED @ 360w
- Selecon PLFresnel LED @ 150w
- Selecon PLCYC LED @ 150w
- Chauvet COLORado 1 Tri Tour @ 93w
- COLORdash Accent @ 10w
- LED UV

**Moving Light**

- Chauvet Maverick Mk2 Profile @ 750w

**Haze**

**Accessories**

- 7.5in 4 Leaf Barn Door

**TYPICAL**

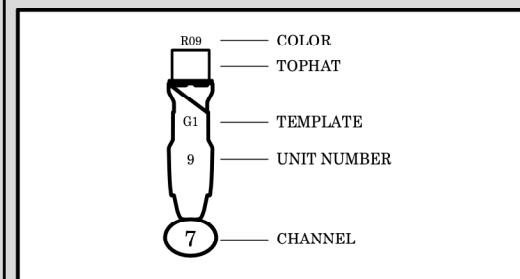

**NOTES**

1. ALL UNITS ON 1" CENTERS UNLESS OTHERWISE NOTED ON PLOT
2. BOOM POSITIONS MARKED AS DISTANCE FROM CL
3. ALL BOOM HEIGHTS MEASURED FROM STAGE DECK (0'-0") TO CLAMP POSITION
4. DROP COLOR, TEMPLATES, AND ACCESSORIES PRIOR TO FOCUS
5. PLEASE HAVE SPARE CUTS OF R119 & R132 AT FOCUS
6. ALL CHANGES/SUBSTITUTIONS MUST BE APPROVED BY DESIGNER

**TEMPLATES**



**REVISIONS**

DATE	CHANGES	WHO
3/21/23	Preliminary	MAO
4/5/23	Final	MAO

**CaLARTS**

PS4 - E407

**PRODUCER:** Park Lytle  
**DIRECTOR:** Damian D. Lewis  
**SCENIC:** Holly Cho  
**COSTUMES:** Karen Ayala  
**SOUND:** Stephen Coblich  
**LIGHTING:** Max Okst  
**ASST. LD:** Evan Brownell  
**LX SUP:** Kate DeWall  
**ME:** Becky King  
**PROGRAM:** Tilda Mingos Seo

**MAX OKST** PLATE  
 (631) 605-8525 | maxokst@gmail.com  
 www.maxokst.com

**LX Deck** 2 OF 3  
 1/2" = 1'-0" Arch D



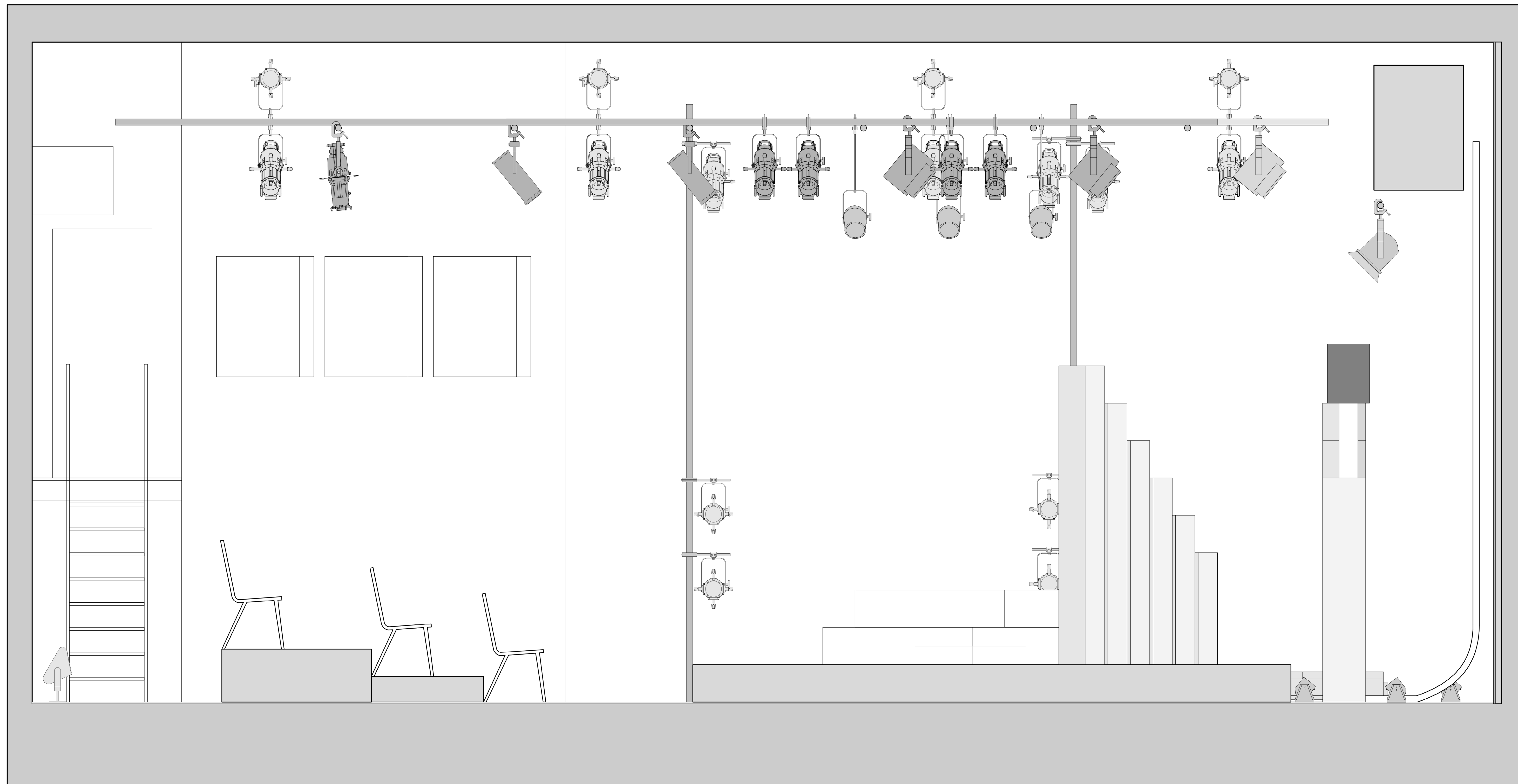

**KEY**

**Conventionals**

- Source 4 28" @ 575w
- Source 4 36" @ 575w
- Source 4 50" @ 575w
- Altman PAR 64 MFL @ 1kw
- Altman Sin Fresnel @ 1kw
- Altman ZS-3 @ 3X750
- Altman 528 3 Circ 6ft @ 12X200

**LED**

- Selecon PL-3 LED @ 360w
- Selecon PLFresnel LED @ 150w
- Selecon PLCYC LED @ 150w
- Chauvet COLORado 1 Tri Tour @ 93w
- COLORdash Accent @ 10w
- LED UV

**Moving Light**

- Chauvet Maverick Mk2 Profile @ 750w

**Haze**

**Accessories**

- 7.5in 4 Leaf Barn Door

**TYPICAL**

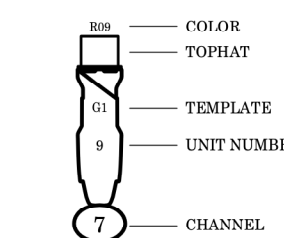

**NOTES**

1. ALL UNITS ON 1" CENTERS UNLESS OTHERWISE NOTED ON PLOT
2. BOOM POSITIONS MARKED AS DISTANCE FROM CL
3. ALL BOOM HEIGHTS MEASURED FROM STAGE DECK (0'-0") TO CLAMP POSITION
4. DROP COLOR, TEMPLATES, AND ACCESSORIES PRIOR TO FOCUS
5. PLEASE HAVE SPARE CUTS OF R119 & R124 AT FOCUS
6. ALL CHANGES/SUBSTITUTIONS MUST BE APPROVED BY DESIGNER

**TEMPLATES**

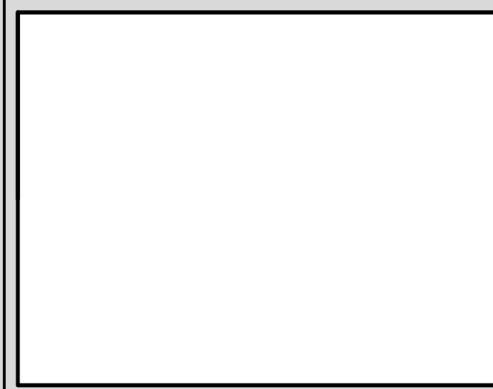

**REVISIONS**

DATE	CHANGES	WHO
3/21/23	Preliminary	MAO
4/5/23	Final	MAO

**caLARTS**

PS4 - E407

**EVERYBODY**

**PRODUCER:** Park Lytle  
**DIRECTOR:** Damian D. Lewis  
**SCENIC:** Holly Cho  
**COSTUMES:** Karen Ayala  
**SOUND:** Stephen Coblich  
**LIGHTING:** Max Okst  
**ASST. LD:** Evan Brownell  
**LX SUP:** Kate DeWall  
**ME:** Becky King  
**PROGRAM:** Tilda Mingos Seo

**MO MAX OKST** PLATE

(631) 605-8525 | maxokst@gmail.com  
www.maxokst.com

**LX Section** 3 OF 3

3/4" = 1'-0" Arch D

This drawing represents visual concepts, suggested construction and fixture placement only. The designer is responsible for determining the structural or electrical requirements of this design. Engineering, construction, handling, or use should be determined by qualified individuals. All materials and construction must comply with the most stringent applicable Federal and Local Fire, Safety, Storage and Environmental Codes.

EVERYBODY

CalArts School of Theatre  
PS4 - E407  
4/2/23

SR

# MAGIC SHEET

SL

LD: MAX OKST

maxokst@gmail.com

www.maxokst.com

(631) 605-9525

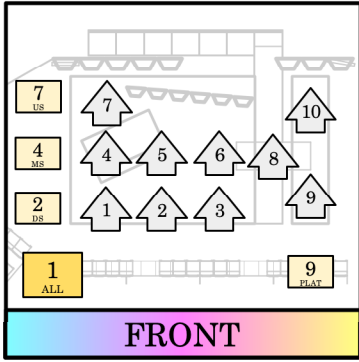

FRONT

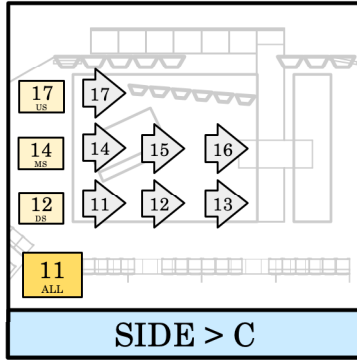

SIDE > C

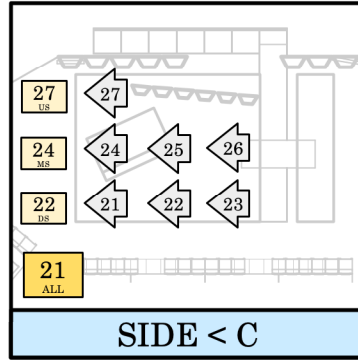

SIDE < C

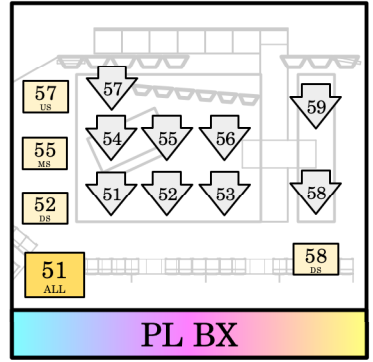

PL BX

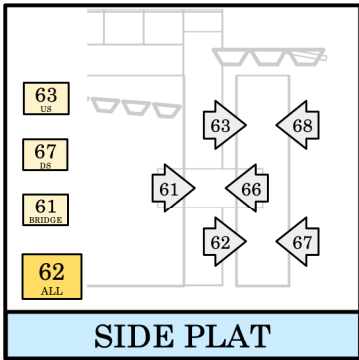

SIDE PLAT

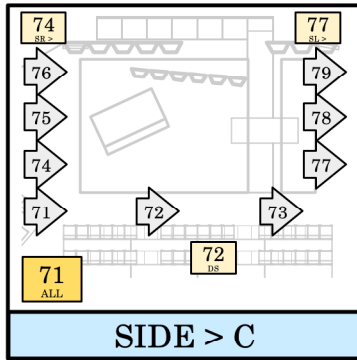

SIDE > C

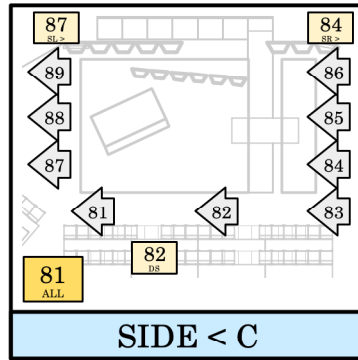

SIDE < C

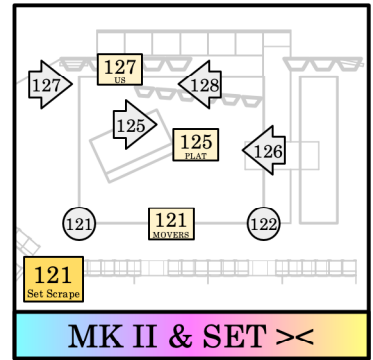

MK II & SET >>

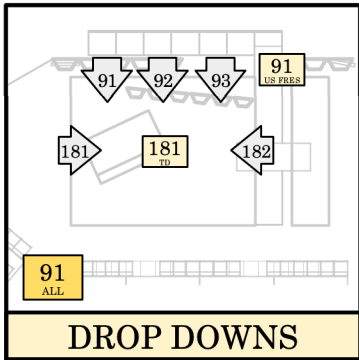

DROP DOWNS

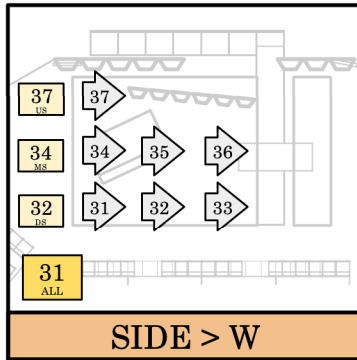

SIDE > W

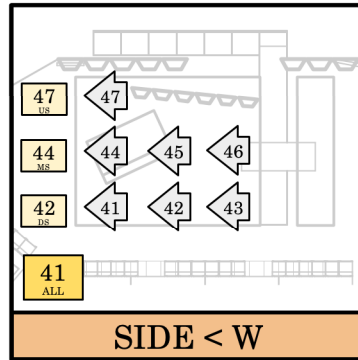

SIDE < W

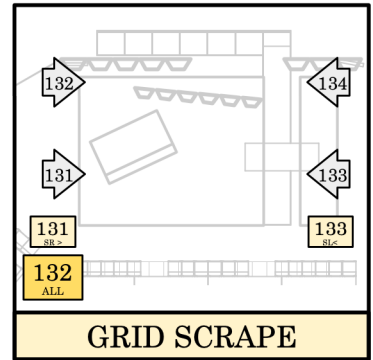

GRID SCRAPE

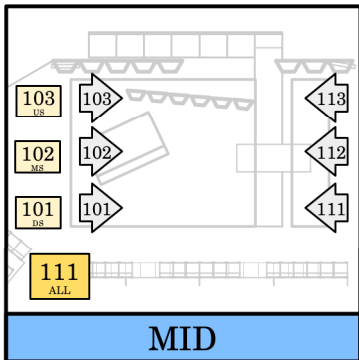

MID

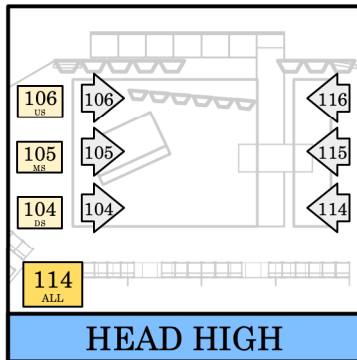

HEAD HIGH

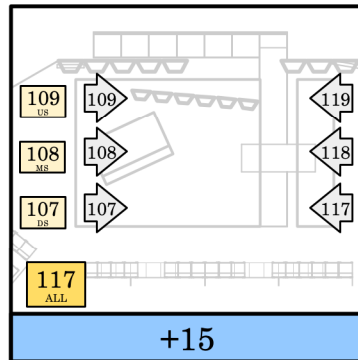

+15

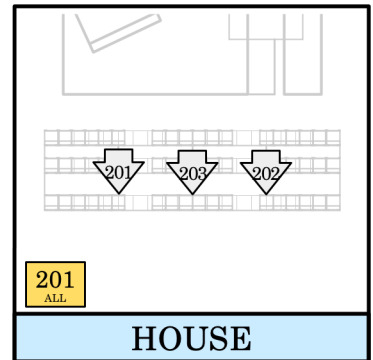

HOUSE

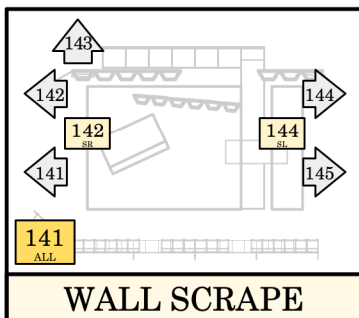

WALL SCRAPE

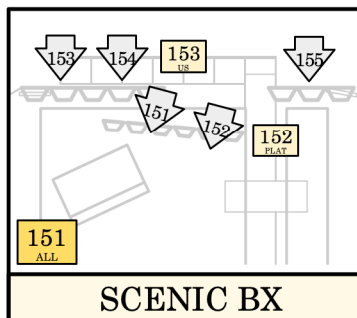

SCENIC BX

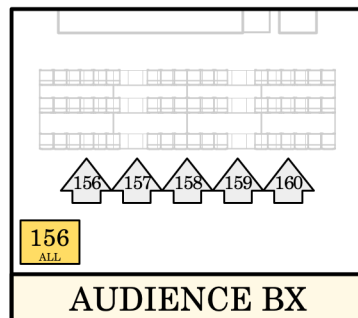

AUDIENCE BX

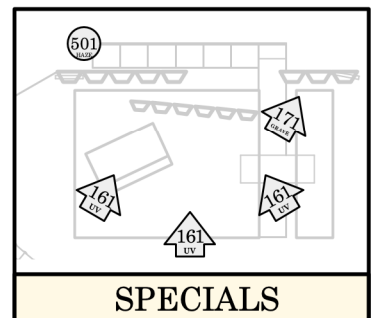

SPECIALS

**FUN HOME**

CalArts School of Theatre  
PS4 - E407  
3/20/23

SR

# MAGIC SHEET

SL

LD: MAX OKST

maxokst@gmail.com  
www.maxokst.com  
(631) 605-9525

**COLOR PALETTES**

1. R60
2. R3207
3. L200
4. UV
5. Red
6. Blue
7. Green
8. White
9. Cyan
10. Yellow
11. Magenta
12. Purple
13. White (Less G)
14. White (Less B)
- 15.
- 17.
- 18.
- 19.
- 20.
- 21.
- 22.
- 23.
- 24.
- 25.

**PRESETS**

1. Column Wash
2. Column Gobo
3. CC Highlight
4. C Full Zoom
5. C Tight Zoom
- 6.
- 7.
- 8.
- 9.
- 10.
- 11.
- 12.
- 13.
- 14.
- 15.
- 17.
- 18.
- 19.
- 20.
- 21.
- 22.
- 23.
- 24.
- 25.

**EFFECTS**

1. BX Fade
- 2.
- 3.
- 4.
- 5.
- 6.
- 7.
- 8.
- 9.
- 10.
- 11.
- 12.
- 13.
- 14.
- 15.
- 17.
- 18.
- 19.
- 20.
- 21.
- 22.
- 23.
- 24.
- 25.

**SPOT 1**

**SPOT 2**

F1:	F4:
F2:	F5:
F3:	F6:

**SPOTS**















**LX TEAM:**

LD: Max Okst	PROG: Tilda Seo
ALD: Evan Brownell	SPOT 1:
LX SUP: Kate DeWall	SPOT 2:
ME: Becky King	

**NOTES**

Empty space for notes.

# Channel Hookup

Chan	Pos	U#	Instrument Type & Load	Color	Gbo	Accessory	Purpose
<b>1</b>	Pipe C	6	Selecon PLFresnel1 LED 150w				DSR Front
<b>2</b>	Pipe C	5	Selecon PLFresnel1 LED 150w				DSC Front
<b>3</b>	Pipe C	3	Selecon PLFresnel1 LED 150w				DSL Front
<b>4</b>	Pipe D	4	Selecon PLFresnel1 LED 150w				MSR Front
<b>5</b>	Pipe D	3	Selecon PLFresnel1 LED 150w				MSC Front
<b>6</b>	Pipe D	2	Selecon PLFresnel1 LED 150w				MSL Front
<b>7</b>	Pipe E	6	Selecon PLFresnel1 LED 150w				USR Front
<b>8</b>	Pipe D	1	Selecon PLFresnel1 LED 150w				Bridge Front
<b>9</b>	Pipe C	1	Selecon PLFresnel1 LED 150w				DSP Front
<b>10</b>	Pipe E	3	Selecon PLFresnel1 LED 150w				USP Front
<b>11</b>	Pipe 11	2	ETC Source4 50deg 575w	 R60+132			DSR Side > C
<b>12</b>	Pipe 9	2	ETC Source4 50deg 575w	 R60+132			DSC > C
<b>13</b>	Pipe 7	1	ETC Source4 50deg 575w	 R60+132			DSL > C
<b>14</b>	Pipe 11	4	ETC Source4 50deg 575w	 R60+132			MSR > C
<b>15</b>	Pipe 9	5	ETC Source4 50deg 575w	 R60+132			MSC > C
<b>16</b>	Pipe 7	3	ETC Source4 50deg 575w	 R60+132			MSL > C
<b>17</b>	Pipe 11	7	ETC Source4 50deg 575w	 R60+132			USR > C
<b>21</b>	Pipe 8	3	ETC Source4 50deg 575w	 R60+132			DSR Side < C
<b>22</b>	Pipe 6	2	ETC Source4 50deg 575w	 R60+132			DSC < C
<b>23</b>	Pipe 4	2	ETC Source4 50deg 575w	 R60+132			DSL < C
<b>24</b>	Pipe 7	5	ETC Source4 50deg 575w	 R60+132			MSR C <
<b>25</b>	Pipe 6	5	ETC Source4 50deg 575w	 R60+132			MSC < C
<b>26</b>	Pipe 4	6	ETC Source4 50deg 575w	 R60+132			MSL < C
<b>27</b>	Pipe 8	5	ETC Source4 50deg 575w	 R60+132			USR < C
<b>31</b>	Pipe 11	3	ETC Source4 50deg 575w	 R3408+R132			DSR Side > W

# Channel Hookup

Chan	Pos	U#	Instrument Type & Load	Color	Gbo	Accessory	Purpose
<b>32</b>	Pipe 9	3	ETC Source4 50deg 575w	 R3408+R132			DSC > W
<b>33</b>	Pipe 7	2	ETC Source4 50deg 575w	 R3408+R132			DSL > W
<b>34</b>	Pipe 11	5	ETC Source4 50deg 575w	 R3408+R132			MSR > W
<b>35</b>	Pipe 9	6	ETC Source4 50deg 575w	 R3408+R132			MSC > W
<b>36</b>	Pipe F	4	ETC Source4 50deg 575w	 R3408+R132			MSL > W
<b>37</b>	Pipe 11	8	ETC Source4 50deg 575w	 R3408+R132			USR > W
<b>41</b>	Pipe 8	4	ETC Source4 50deg 575w	 R3408+R132			DSR Side < W
<b>42</b>	Pipe 6	3	ETC Source4 50deg 575w	 R3408+R132			DSC < W
<b>43</b>	Pipe 4	3	ETC Source4 50deg 575w	 R3408+R132			DSL < W
<b>44</b>	Pipe 7	6	ETC Source4 50deg 575w	 R3408+R132			MSR < W
<b>45</b>	Pipe 6	6	ETC Source4 50deg 575w	 R3408+R132			MSC < W
<b>46</b>	Pipe 4	7	ETC Source4 50deg 575w	 R3408+R132			MSL < W
<b>47</b>	Pipe 8	6	ETC Source4 50deg 575w	 R3408+R132			USR < W
<b>51</b>	Pipe 9	4	Selecon PL 3 LED 360w				DSR BX
<b>52</b>	Pipe E	2	Selecon PL 3 LED 360w				DSC BX
<b>53</b>	Pipe E	4	Selecon PL 3 LED 360w				DSL BX
<b>54</b>	Pipe 9	8	Selecon PL 3 LED 360w				MSR BX
<b>55</b>	Pipe G	7	Selecon PL 3 LED 360w				MSC BX
<b>56</b>	Pipe 6	7	Selecon PL 3 LED 360w				MSL BX
<b>57</b>	Pipe 9	10	Selecon PL 3 LED 360w				USR BX
<b>58</b>	Pipe F	2	Selecon PL 3 LED 360w				DSP BX
<b>59</b>	Pipe G	1	Selecon PL 3 LED 360w				USP BX
<b>61</b>	Pipe E	5	ETC Source4 50deg 575w	 R60+132			Bridge >
<b>62</b>	Pipe E	4	Altman 8in Fresnel 1kW	 R3408		7.5" Barndoor	DSP Side >
<b>63</b>	Pipe G	9	Altman 8in Fresnel 1kW	 R3408		7.5" Barndoor	MSP Side >

Chan	Pos	U#	Instrument Type & Load	Color	Gbo	Accessory	Purpose
<b>66</b>	Pipe E	2	ETC Source4 50deg 575w	 R60+132			Bridge <
<b>67</b>	Pipe E	1	Altman 8in Fresnel 1kW	 R3408		7.5" Barndoor	DSP Side <
<b>68</b>	Pipe G	4	Altman 8in Fresnel 1kW	 R3408		7.5" Barndoor	MSP Side <
<b>71</b>	Pipe 12	1	ETC Source4 50deg 575w	 R60+R132		6.25" SHORT TOP HAT	DS Aisle >
<b>72</b>	Pipe 10	2	Source 4 36° 575w	 R60+R132		6.25" TOP HAT	DS Aisle >
<b>73</b>	Pipe 8	2	Source 4 36° 575w	 R60+R132		6.25" TOP HAT	DS Aisle >
<b>74</b>	Pipe E	2	ETC Source4 50deg 575w	 R60+R132			DDR >
<b>75</b>	Pipe F	3	ETC Source4 50deg 575w	 R60+R132			MDR >
<b>76</b>	Pipe G	4	ETC Source4 50deg 575w	 R60+R132			UDR >
<b>77</b>	Pipe 4	1	ETC Source4 50deg 575w	 R60+R132			DDL >
<b>78</b>	Pipe 4	8	ETC Source4 50deg 575w	 R60+R132			MDL >
<b>79</b>	Pipe 4	10	ETC Source4 50deg 575w	 R60+R132			UDL >
<b>81</b>	Pipe 5	2	Source 4 36° 575w	 R60+R132		6.25" TOP HAT	DS Aisle <
<b>82</b>	Pipe 3	2	Source 4 36° 575w	 R60+R132		6.25" TOP HAT	DS Aisle <
<b>83</b>	Pipe 1	2	ETC Source4 50deg 575w	 R60+R132		6.25" SHORT TOP HAT	DS Aisle <
<b>84</b>	Pipe 1	4	ETC Source4 50deg 575w	 R60+R132			DDL <
<b>85</b>	Pipe F	5	ETC Source4 50deg 575w	 R60+R132			MDL <
<b>86</b>	Pipe 1	7	ETC Source4 50deg 575w	 R60+R132			UDL <
<b>87</b>	Pipe 9	1	ETC Source4 50deg 575w	 R60+R132			DDR <
<b>88</b>	Pipe F	7	ETC Source4 50deg 575w	 R60+R132			MDR <
<b>89</b>	Pipe G	9	ETC Source4 50deg 575w	 R60+R132			UDR <

Chan	Pos	U#	Instrument Type & Load	Color	Gbo	Accessory	Purpose
<b>91</b>	US Pipe	4	Altman 8in Fresnel 1kW	L201		7.5" Barndoor	LPRC BX
	US Pipe	5	Altman 8in Fresnel 1kW	L201		7.5" Barndoor	LPR BX
<b>92</b>	US Pipe	3	Altman 8in Fresnel 1kW	L201		7.5" Barndoor	LPC BX
<b>93</b>	US Pipe	1	Altman 8in Fresnel 1kW	L201		7.5" Barndoor	LPL BX
	US Pipe	2	Altman 8in Fresnel 1kW	L201		7.5" Barndoor	LPLC BX
<b>101</b>	1 Boom R		ETC Source 4 26deg 575w	L200+R132		6.25" TOP HAT	DSR Mid >
<b>102</b>	2 Boom R		ETC Source 4 26deg 575w	L200+R132		6.25" TOP HAT	MSR Mid >
<b>103</b>	2 Boom R		ETC Source 4 26deg 575w	L200+R132		6.25" TOP HAT	USR Mid >
<b>104</b>	1 Boom R		ETC Source 4 26deg 575w	L200+R132		6.25" TOP HAT	DSR HH >
<b>105</b>	2 Boom R		ETC Source 4 26deg 575w	L200+R132		6.25" TOP HAT	MSR HH >
<b>106</b>	2 Boom R		ETC Source 4 26deg 575w	L200+R132		6.25" TOP HAT	USR HH >
<b>107</b>	1 Boom R		ETC Source 4 26deg 575w	L202+R119		6.25" TOP HAT	DSR +15 >
<b>108</b>	2 Boom R		ETC Source 4 26deg 575w	L202+R119		6.25" TOP HAT	MSR +15 >
<b>109</b>	2 Boom R		ETC Source 4 26deg 575w	L202+R119		6.25" TOP HAT	USR +15 >
<b>111</b>	1 Boom L		ETC Source 4 26deg 575w	L200+132		6.25" TOP HAT	DSL Mid <
<b>112</b>	2 Boom L		ETC Source 4 26deg 575w	L200+132		6.25" TOP HAT	MSL Mid <
<b>113</b>	2 Boom L		ETC Source 4 26deg 575w	L200+132		6.25" TOP HAT	USL Mid <
<b>114</b>	1 Boom L		ETC Source 4 26deg 575w	L200+132		6.25" TOP HAT	DSL HH <

# Channel Hookup

Chan	Pos	U#	Instrument Type & Load	Color	Gbo	Accessory	Purpose
<b>115</b>	2 Boom L		ETC Source 4 26deg 575w	L200+132		6.25" TOP HAT	MSL HH <
<b>116</b>	2 Boom L		ETC Source 4 26deg 575w	L200+132		6.25" TOP HAT	USL HH <
<b>117</b>	1 Boom L		ETC Source 4 26deg 575w	L202+R119		6.25" TOP HAT	DSL +15 <
<b>118</b>	2 Boom L		ETC Source 4 26deg 575w	L202+R119		6.25" TOP HAT	MSL +15 <
<b>119</b>	2 Boom L		ETC Source 4 26deg 575w	L202+R119		6.25" TOP HAT	USL +15 <
<b>121</b>	Pipe C	7	Chauvet Maverick Mk2 Profile 750w				SR Mover
<b>122</b>	Pipe C	2	Chauvet Maverick Mk2 Profile 750w				SL Mover
<b>125</b>	Pipe 11	6	Chauvet COLORado 1 Tri Tour 93w				Plat Pilars
<b>126</b>	Pipe E	5	Chauvet COLORado 1 Tri Tour 93w				Plat Pilars
<b>127</b>	Pipe 12	5	Chauvet COLORado 1 Tri Tour 93w				US Pilars
<b>128</b>	Pipe 5	7	Chauvet COLORado 1 Tri Tour 93w				US Pilars
<b>131</b>	Pipe 11	1	Source 4 36° 575w	CLR		6.25" TOP HAT	Grid Scrape >
	Pipe 13	1	Source 4 36° 575w	CLR		6.25" TOP HAT	Grid Scrape >
<b>132</b>	Pipe 13	2	Source 4 36° 575w	CLR		6.25" TOP HAT	Grid Scrape >
	Pipe 13	3	Source 4 36° 575w	CLR		6.25" TOP HAT	Grid Scrape >
<b>133</b>	Pipe 1	1	Source 4 36° 575w	CLR		6.25" TOP HAT	Grid Scrape <
	Pipe 1	3	Source 4 36° 575w	CLR		6.25" TOP HAT	Grid Scrape <
	Pipe 1	6	Source 4 36° 575w	CLR		6.25" TOP HAT	Grid Scrape <







# Channel Hookup

Chan	Pos	U#	Instrument Type & Load	Color	Gbo	Accessory	Purpose
<b>141</b>	Deck	1	Altman Zip Strip 3 Circuit 3w	<input type="radio"/> CLR			Wall Scrape
	Deck	1	Altman Zip Strip 3 Circuit 3w	<input type="radio"/> CLR			Wall Scrape
	Deck	1	Altman Zip Strip 3 Circuit 3w	<input type="radio"/> CLR			Wall Scrape
<b>142</b>	Deck	2	Altman Zip Strip 3 Circuit 3w	<input type="radio"/> CLR			Wall Scrape
	Deck	2	Altman Zip Strip 3 Circuit 3w	<input type="radio"/> CLR			Wall Scrape
	Deck	2	Altman Zip Strip 3 Circuit 3w	<input type="radio"/> CLR			Wall Scrape
<b>143</b>	Deck	3	Altman Zip Strip 3 Circuit 3w	<input type="radio"/> CLR			Wall Scrape
	Deck	3	Altman Zip Strip 3 Circuit 3w	<input type="radio"/> CLR			Wall Scrape
	Deck	3	Altman Zip Strip 3 Circuit 3w	<input type="radio"/> CLR			Wall Scrape
<b>144</b>	Deck	4	Altman Zip Strip 3 Circuit 3w	<input type="radio"/> CLR			Wall Scrape
	Deck	4	Altman Zip Strip 3 Circuit 3w	<input type="radio"/> CLR			Wall Scrape
	Deck	4	Altman Zip Strip 3 Circuit 3w	<input type="radio"/> CLR			Wall Scrape
<b>145</b>	Deck	5	Altman Zip Strip 3 Circuit 3w	<input type="radio"/> CLR			Wall Scrape
	Deck	5	Altman Zip Strip 3 Circuit 3w	<input type="radio"/> CLR			Wall Scrape
	Deck	5	Altman Zip Strip 3 Circuit 3w	<input type="radio"/> CLR			Wall Scrape
<b>151</b>	Platform	8	Altman 528 3 Circ 6ft 12w	<input type="radio"/> CLR			Column BX
	Platform	8	Altman 528 3 Circ 6ft 12w	<input type="radio"/> CLR			Column BX
	Platform	8	Altman 528 3 Circ 6ft 12w	<input type="radio"/> CLR			Column BX
<b>152</b>	Platform	9	Altman 528 3 Circ 6ft 12w	<input type="radio"/> CLR			Column BX
	Platform	9	Altman 528 3 Circ 6ft 12w	<input type="radio"/> CLR			Column BX
	Platform	9	Altman 528 3 Circ 6ft 12w	<input type="radio"/> CLR			Column BX
<b>153</b>	Deck	6	Altman 528 3 Circ 6ft 12w	<input type="radio"/> CLR			Column BX
	Deck	6	Altman 528 3 Circ 6ft 12w	<input type="radio"/> CLR			Column BX
	Deck	6	Altman 528 3 Circ 6ft 12w	<input type="radio"/> CLR			Column BX

# Channel Hookup

Chan	Pos	U#	Instrument Type & Load	Color	Gbo	Accessory	Purpose
<b>154</b>	Deck	7	Altman 528 3 Circ 6ft 12w	<input type="radio"/> CLR			Column BX
	Deck	7	Altman 528 3 Circ 6ft 12w	<input type="radio"/> CLR			Column BX
	Deck	7	Altman 528 3 Circ 6ft 12w	<input type="radio"/> CLR			Column BX
<b>155</b>	Deck	11	Altman 528 3 Circ 6ft 12w	<input type="radio"/> CLR			Column BX
	Deck	11	Altman 528 3 Circ 6ft 12w	<input type="radio"/> CLR			Column BX
	Deck	11	Altman 528 3 Circ 6ft 12w	<input type="radio"/> CLR			Column BX
<b>156</b>	House	1	Selecon PLCYC LED 150w				Audience BX
<b>157</b>	House	2	Selecon PLCYC LED 150w				Audience BX
<b>158</b>	House	3	Selecon PLCYC LED 150w				Audience BX
<b>159</b>	House	4	Selecon PLCYC LED 150w				Audience BX
<b>160</b>	House	5	Selecon PLCYC LED 150w				Audience BX
<b>161</b>	Pipe 5	3	HWay 100W LED UV 100w				UV
	Pipe 10	3	HWay 100W LED UV 100w				UV
	Pipe C	4	HWay 100W LED UV 100w				UV
<b>171</b>	Deck	10	COLORdash Accent 10w				Grave Foot
<b>181</b>	Pipe 10	4	PAR 56 MFL 1kW	<input checked="" type="radio"/> R98		18" Taildown+ 7.5" Concentric Ring	Eye Candy
	Pipe 10	5	PAR 56 MFL 1kW	<input checked="" type="radio"/> R98		18" Taildown+ 7.5" Concentric Ring	Eye Candy
	Pipe 10	6	PAR 56 MFL 1kW	<input checked="" type="radio"/> R98		18" Taildown+ 7.5" Concentric Ring	Eye Candy
<b>182</b>	Pipe 5	4	PAR 56 MFL 1kW	<input checked="" type="radio"/> R98		18" Taildown+ 7.5" Concentric Ring	Eye Candy
	Pipe 5	5	PAR 56 MFL 1kW	<input checked="" type="radio"/> R98		18" Taildown+ 7.5" Concentric Ring	Eye Candy
	Pipe 5	6	PAR 56 MFL 1kW	<input checked="" type="radio"/> R98		18" Taildown+ 7.5" Concentric Ring	Eye Candy

Chan	Pos	U#	Instrument Type & Load	Color	Gbo	Accessory	Purpose
<b>201</b>	Pipe B	4	PAR 64 WFL 1kW	 L201			House
	Pipe B	5	PAR 64 WFL 1kW	 L201			House
<b>202</b>	Pipe B	1	PAR 64 WFL 1kW	 L201			House
	Pipe B	2	PAR 64 WFL 1kW	 L201			House
<b>203</b>	Pipe B	3	ETC Source4 50deg 575w	 L201+R119			Aisle
<b>501</b>	Deck	12	Chauvet AmHAZE II 760w				Hazer

# Everybody

## LX Cue Sheet



4.27.23

CUE #	PT	PG	FADE		DLA	F/H	BLK	WHEN CALLED	DESCRIPTION
			UP	DW					
1		7	3					Preshow	House Full
3		7	8					Usher Enters	House Half & Usher - DS of Plat - he also comes onstage
5		8	40					Usher "Are you feeling fidgety?"	Add more DSP & MSP
6		9	30					Usher gets to main plat	Take out DS Trench
6.5		10	5					Before Usher Steps off platform	DS Trench Back Up
7		10	3					God Arrives	God Arrives
7.5		10	3					God gets on platform	Take out trench
8		11	0			F0		On god's Second Clap	Add stage
8.1			3						Mover Mark
9		13	3					God "DEATH? REVEAL YOURSELF!"	SR Plat & Bridge
11		14	25					Visual *Death crosses onto bridge*	Take out SR Plat & Bridge
13		14	10			F10		Death "Where even is Everybody?"	Add DS Edge
13.1		14	3						Mover Mark
15		16	7					Death Whispers "And being found..."	Intensity zoom on Death
17		16	7					Death "OK now let's go"	Restore
19		16	15					Everybodies Step up on plat	Off of DS Edge
21		17	7					Alec & Austin "This is so scary"	Add Pars to plat
23		17	7					Death steps off plat "and certainly no mans"	Slow up on BX
25		18	20					"Then let me go find someone"	Pull just DS - w/ edge

# Everybody

## LX Cue Sheet



4.27.23

CUE #	PT	PG	FADE		DLA	F/H	BLK	WHEN CALLED	DESCRIPTION
			UP	DW					
27		18	5					Death "OKAY THAT IS..."	Add US and Mover Ledge
29		19	7					Death "And now out of thy..."	Pull to Plat for Death and C for Evby
30		20	0					With sound for ticks	BX
31		20	0					Death "Starting now"	Blackout
33		21	3					V.O. Starts "Was that a dream or was that..."	Low Sides w/ set highlights
35		23	0					Anticipate Friendship "Oh my god!"	Cool Studio
37		24	10					Friendship "Do you ever look back"	Pull MS
38		24	0					Tick Tock	BX
38.5		24	2					Tick Tocks over	Restore
39		24	20					Everybody "Literally?"	Restore
41		26	20					Everybody "But I'll never see you again"	Pull to Plat
43		27	0					Friendship "Please, come look!"	Blackout
45		28	5					V.O. Starts "You idiot"	Low Sides w/ set highlights
47		29	15					Everybody gets circled	Brighter
49		29	0					Cousin "Everybody! What is up..."	Studio 2 - a bit warmer
51		32	30					Everybody "This is so annoying!"	Brighter Plat. Maybe pars?
55		34	0					Cousin "Do all you guys know about "God"!?"	Blackout
57		35	5					V.O. Starts "You idiot"	Low Sides w/ set highlights
58		36	0					Sound R	Silhouette

# Everybody

## LX Cue Sheet



4.27.23

CUE #	PT	PG	FADE		DLA	F/H	BLK	WHEN CALLED	DESCRIPTION
			UP	DW					
59		36	3					Stuff scene dialogue Starts	Studio 3 - even a bit warmer
61		38	20					Stuff "We have fun together-"	Pull MS
63		38	15					Everybody "You... shit"	Add DS back
67		39	5					Stuff "AND GET A GRIP"	Blackout
69		41	5					After video	Booms, BX, and Aisle up
71		42	5					Love "Yeah, youre dying"	add 204
72		42	7					E Steps up on the platform	Trench out
73		43	45					Love "What can you do to what?"	take out 204 and DS Edge
75		44	30					Love "Now run while you say it"	Shift to just BX
77		45	10					Visual *Love steps up on platform*	Highlight love on plat
79		46	5					Music Starts	Plat color turnes into UV
79.5		46						Skeletons get up	UV on
79.6		46						First sketeton spin	Haze on
79.7		46	0					Grave Reveal	UV Out
80		46	4		2.5			Grave is turned	Grave Light on
81		46	5					Death steps out of grave	Full Stage
82		48	10					Everybody "One Second"	Pull C
83	1	51	10					Everybody "Wait! WAIT! WH-"	Grave revealed - Grid lights
84	2	51	30						Wall lights

# Everybody

## LX Cue Sheet



4.27.23

CUE #	PT	PG	FADE		DLA	F/H	BLK	WHEN CALLED	DESCRIPTION
			UP	DW					
83.5		51						US of deth platform	Pull down to grave
84		51	3			F0		Grave Closed	Grave out
85		52	7					Grave is closed	Grave Closed
87		52	5					Death "I don't know. Would it?"	Add DS Edge
88		52	5					Time steps up on platform	Take out trench
89		54	5					Usher "... but just in case:"	Up on plat
90		54	20					Usher steps onto bridge	Out on trench
91		54	15					Usher "Or something"	Shift to just plat
93		54	0					After Usher "Have a good night."	Blackout
95		54	5					Places for Curtain call	Curtain Call
96		54	5					Grave turns	Everybody Grave light
97		54	3					Curtain Call over	House up