

## Visit Us Online

For more information about Basalite paving stones, retaining walls, accessories, patterns or installation instructions, visit us online at [www.basalite.com](http://www.basalite.com).

Offered by:



355 Greg Street  
Sparks, NV 89431  
775-358-1200

ALBERTA • BRITISH COLUMBIA • CALIFORNIA • COLORADO • IDAHO • NEVADA • OREGON • WASHINGTON

[www.basalite.com](http://www.basalite.com)



©2015 Basalite® Concrete Products, LLC. All trademarks ® are registered trademarks. Bayfield® and Brisa® wall systems are manufactured under license from Anchor Wall Systems, Inc. (AWS). "Bayfield", "Brisa" and "Torpedo" are trademarks of AWS. The wall system blocks are covered by the AWS Limited Warranty. For a complete copy, visit your local dealer or see [anchorwall.com](http://anchorwall.com). Stonewall® II is a registered trademark of WestBlock Systems and a licensed product of WestBlock Development, LLC. Stonewall® II is protected under U.S. Patent D652.153, D652.154, D652.155, D652.531. Additional Patents pending in the U.S. and Canada. The U.S. Green Building Council Member logo is a trademark owned by the U.S. Green Building Council and is used by permission.

BA502e-NV OP 50,000 2/27/15



**BASALITE®**  
Hardscapes  
**GREAT  
HARDSCAPES  
START HERE®**

[www.basalite.com](http://www.basalite.com)



## BUILDING VALUES

For over 30 years, Basalite® has worked on growing our business by building relationships.

We have created strong bonds with our dealers, masons, architects, engineers and licensed contractors. From working together with the common purpose of installing the finest hardscape products available, we have seen our products placed in settings that range from practical to magical. At Basalite®, we are committed to being the best in the industry. Our focus now, just as it was when we opened our doors all those years ago, is on service, quality and innovation. Those are the values that have made us the industry leader we are today and the same principles that will guide us far into the future.

Cover: Artisan Slate pavers in Positano/Naples blend, Necessaries Contemporary Fireplace in Positano and Columns in Rox Pro Craftsman Panels in Placer Gold  
 Left and above: Country Cobble pavers in Venice

# CONTENTS

<b>INTRODUCTION</b>	
Building Values	2
Inspiring Outdoor Spaces	3
<b>SELECT SERIES PAVERS</b>	
Italian Renaissance	9
Artisan Slate	10
Artisan Slate Premier	11
Artisan Flagstone	12
Heartland	13
Country Cobble	14
San Francisco Cobblestone	15
Circle Kits	16
Bullnose	17
<b>TRADITIONAL SERIES PAVERS</b>	
Mission	18
<b>PERMEABLE SERIES PAVERS</b>	
Permeable Italian Renaissance	19
Permeable Mission	20
Permeable Cobblestone	21
SF Rima	22
<b>SELECT SERIES WALLS</b>	
StoneWall® II	23
StoneWall® II Column Kit	24
Bayfield® Retaining Wall	25
Bayfield® Freestanding Wall	26
<b>TRADITIONAL SERIES WALLS</b>	
Estate Wall	27
<b>OUTDOOR LIVING KITS</b>	
Necessaries Kits	28
Necessaries Accessories	29
<b>ACCESSORY ITEMS</b>	30
<b>SPECIFICATIONS</b>	31
<b>PATTERNS</b>	39
<b>INSTALLATION INSTRUCTIONS</b>	41

**Award Winner!**  
"Pond's Circular Whirlwind"  
HNA Hardscape Project  
Award Winner

Don't fight it.  
**Basalite it!**®



## INSPIRING OUTDOOR SPACES

Hardscape projects of all types and sizes come to life using Basalite® materials. With our large selection of products, colors and textures, that outdoor living space you've been dreaming of installing can become reality.

Left and above: Italian Renaissance pavers and Italian Renaissance Circle Kit in Positano

### QUALITY ASSURANCE

All of our products are manufactured to meet or exceed industry specifications. Our commitment to quality ensures consistent product strength and durability that will withstand the test of time and the elements.

### EASE OF INSTALLATION

Basalite® hardscapes can be installed by a do-it-yourselfer, or by a professional hardscape contractor. For installation instructions, visit us online at [www.basalite.com](http://www.basalite.com) or visit a dealer near you.

### LOW MAINTENANCE

Pavers require less maintenance than other paving materials. Their strength, durability and mortarless design eliminate the patching and resurfacing frequently required when asphalt, poured or stamped concrete is used.

### LONG LIFE

Pavers are stronger and more durable than asphalt, poured concrete, and stamped concrete and are built to handle the daily weight stresses of vehicle and pedestrian traffic.

### SPECIAL ORDERS

Custom manufactured colors are available by special order. For more information, including lead time and order minimums, please contact your local Basalite dealer.

**New!**  
Ready-to assemble outdoor living kits!



**NECESSARIES OUTDOOR LIVING KITS**  
Transform your outdoor living area to a backyard destination with the Necessaries kits by Basalite. Each kit comes with everything you need to build, including pre-cut block sized to fit, reinforcements, adhesive, and easy to read, step by step instructions. Shown: Necessaries Dining Table Kit in Desert.



Shown: Necessaries Grand Fire pit Kit with seat in Bluestone



**NECESSARIES TABLE KITS**  
No patio is complete without a place for guests to enjoy tasty hors d'oeuvres, cool drinks, and conversation. The Necessaries table kits will fit nicely into any outdoor space, remain solid and stable during severe weather, and outlast all others. Shown: Necessaries Pub Table Kit in Desert.



Shown: Necessaries Compact Waterfall Kit in Bluestone

INTRODUCTION



5 | Inspiring Outdoor Spaces  
Shown: Necessaries Compact Grill Kit in Bluestone



**NECESSARIES FIREPLACE KITS**  
A fireplace can transform any backyard into a comfortable and stylish gathering place, no matter how large or small. Shown: Necessaries Compact Fireplace Kit in Desert.



**NO**  
Cutting or mortaring!

Shown: Necessaries Compact Bar Kit in Bluestone



**NECESSARIES SEAT WALL KITS**  
Seat Walls help define your outdoor living space, add privacy, and create convenient seating. Shown: Necessaries Lakeland Seat Wall Kit in Bluestone

## PATIOS

Increase your home's livable space by creating welcoming outdoor areas for entertaining and relaxation. Shown: Bayfield® Freestanding Wall and Artisan Slate Premier Series\* pavers in Positano. (\*Special Order)



Shown: Necessaries Grand BBQ Kit in Santa Fe



## OUTDOOR KITCHENS, FIRE PITS & FIREPLACES

Whether it's a cozy breakfast with your spouse, or a lively dinner with family and friends, there is nothing like cooking, eating and entertaining outdoors. Shown: Necessaries Contemporary Fireplace Kit in Bluestone.



## WATER FEATURES

Not everyone can live on a quiet lakeshore, but anyone can enjoy the sounds of water in their backyard. Shown: Necessaries Grand Waterfall Kit in Bluestone.



Shown: Necessaries Pillar with Glass Kit in Desert

## DRIVEWAYS

Gain dramatic appeal by combining unique textures, colors and styles that complement your home's exterior. Shown: Italian Renaissance pavers in Positano.





# ITALIAN RENAISSANCE

Interlocking Paving Stones

The Italian Renaissance collection recreates the textured surface and hand-cobbled appearance of stone slab roads once naturally antiqued by carriage wheels and horses' hooves.



Above and Right: Italian Renaissance pavers in Positano



# ARTISAN SLATE

Interlocking Paving Stones

This sleek collection easily complements any home or landscape. Artisan Slate's subtle texture and natural beauty provide the look of real stone, with the strength and durability of an interlocking paving stone.



Left and Above: Artisan Slate pavers in Positano

## COLORS



Positano



Venice



Sienna



Naples



*A gentle curving Running Bond not only helps define a new area but adds visual drama.*

## COLORS



Positano



## ARTISAN SLATE PREMIER\*

Interlocking Paving Stones

Artisan Slate Premier is designed to provide a bold paver solution with the highest of flexibility in design patterns. Each stone features subtle textures that provide the look of real stone combined with the strength and durability of a paving stone.

\*Available by special order only.



Above and Right: Artisan Slate Premier pavers in Positano



## ARTISAN FLAGSTONE

Interlocking Paving Stones

Available in a range of beautiful earthtone colors, Artisan Flagstone features five unique surface textures and patterns that naturally appear in flagstone. Installation is easy due to its unique spacer design and alignment grooves.



Above and Left: Artisan Flagstone pavers in Venice

### COLORS

\*Artisan Slate Premier pavers are available by special order only.



Positano



Venice

*Overlay a pool deck or other old slab surface with pavers for an instant, cost-effective makeover.*



*Use a paver joint sand enhanced with polymers that hardens with moisture, it won't wash out like regular sand.*



Positano



Venice



# HEARTLAND\*

Interlocking Paving Stones

The Heartland Paver is a single-sized system that has four unique slate topped patterns. These four patterns give the appearance of a thirteen-piece, random paver system. The Heartland Paver System is easy to install, due to its spacer design.

\*Available by special order only.



Right and Above: Heartland pavers in Positano



# COUNTRY COBBLE

Interlocking Paving Stones

Old-world charm can be as close as your own backyard with Basalite®'s Country Cobble pavers. Country Cobble's square, rectangle and mega styles are crafted in organic hues that can be custom blended at the time of installation.



Left and Above: Country Cobble pavers in Cottage Blend

### COLORS

\*Heartland pavers are available by special order only.



Positano

*Increase your home's livable space by creating welcoming outdoor areas for entertaining and relaxation.*



### COLORS

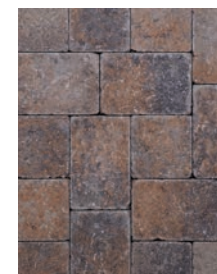

Positano



Venice

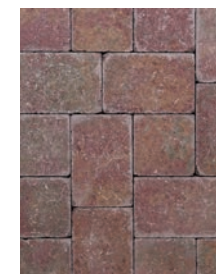

Sienna

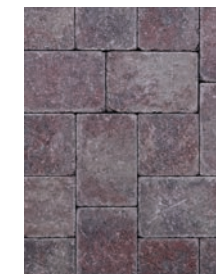

Naples

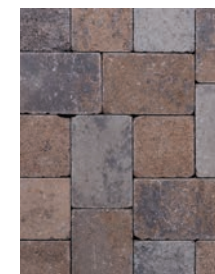

Cottage Blend

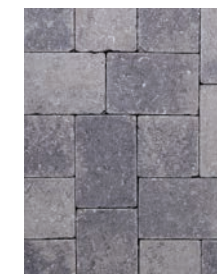

Charcoal



Tan Charcoal



Terra Cotta

NOTE: Printed colors shown in this brochure may vary from actual product colors. We recommend selecting colors from actual product samples. Custom colors are available by special order - please contact your local dealer.

NOTE: Printed colors shown in this brochure may vary from actual product colors. We recommend selecting colors from actual product samples. Custom colors are available by special order - please contact your local dealer.





## SAN FRANCISCO COBBLESTONE

Interlocking Paving Stones

For designs that require more formal styling, this paver offers the traditional look and feel of centuries-old cobbled block. This collection provides the opportunity to design complementary walls and stairs to complete your hardscape.



Right and Above: San Francisco Cobblestone pavers in Positano



## CIRCLE KITS

Interlocking Paving Stones

Add visual interest to your hardscape space with a circle inlay. The Basalite circle kit requires no cutting and is designed to compliment our Italian Renaissance and San Francisco Cobblestone paver collections.



Left and Above: Italian Renaissance Circle Kit in Positano

### COLORS



Positano Venice Sienna Naples \*Milan (Special Order) Carmel Comstock Blend Donner Blend Marin Mendocino Pacifica

NOTE: Printed colors shown in this brochure may vary from actual product colors. We recommend selecting colors from actual product samples. \*Custom colors are available by special order - please contact your local dealer.

### COLORS



SF Cobblestone Positano SF Cobblestone Venice SF Cobblestone Sienna Italian Renaissance Positano Italian Renaissance Venice Italian Renaissance Sienna

NOTE: Printed colors shown in this brochure may vary from actual product colors. We recommend selecting colors from actual product samples. Custom colors are available by special order - please contact your local dealer.



## BULLNOSE

Interlocking Paving Stones

The perfect finishing touch for your pool deck, raised patio, jacuzzi, seating walls or stair treads. Our bullnose pavers have a smooth, rounded edge and are available in both a tumbled and untumbled finish to perfectly complement our pavers and walls.



Right and Above: Bullnose pavers in Naples/Positano blend



## MISSION

Interlocking Paving Stones

For a more traditional approach to landscape design, try Basalite® Mission Pavers. Even with its simple shape, Mission pavers can be arranged in several appealing patterns, such as Herringbone, Basket Weave, or Running Bond.



Left: Mission pavers in Carmel  
Above: Mission pavers in Mendocino

### COLORS

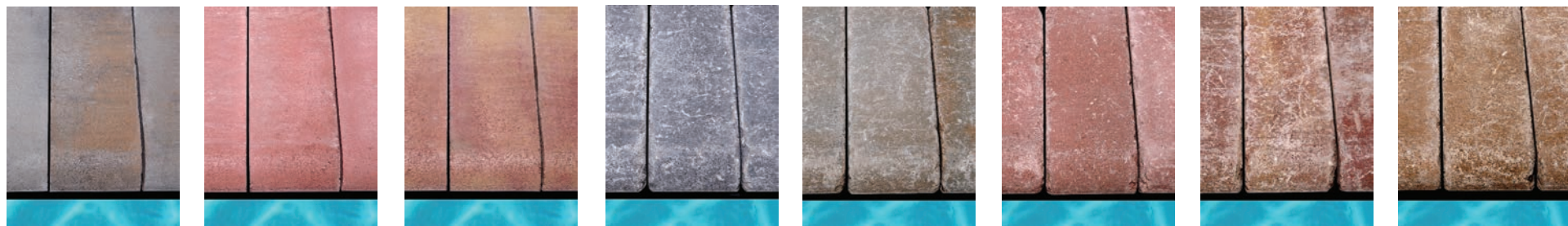

Positano Red Sienna Tumbled Charcoal Tumbled Positano Tumbled Red Tumbled Sienna Tumbled Tan

NOTE: Printed colors shown in this brochure may vary from actual product colors. We recommend selecting colors from actual product samples. Custom colors are available by special order - please contact your local dealer.

### COLORS



Pacifica Carmel Mendocino

NOTE: Printed colors shown in this brochure may vary from actual product colors. We recommend selecting colors from actual product samples. Custom colors are available by special order - please contact your local dealer.



# PERMEABLE ITALIAN RENAISSANCE\*

Permeable Paving Stones

Permeable Italian Renaissance\* pavers recreate the textured surface and hand-cobbled appearance of stone slab roads from ancient times.

\*Available by special order only.



Left and Above: Permeable Italian Renaissance pavers in Positano

### COLORS

\*Permeable Italian Renaissance pavers are available by special order only.



Positano



*Permeable pavers are the perfect choice for any eco-friendly project and can meet LEED® credit requirements.*



*Create a clean and sophisticated look with the use of a Classic Herringbone or Basket Weave pattern.*



# PERMEABLE MISSION\*

Permeable Paving Stones

Permeable Mission is the perfect companion for any environmentally-sensitive or green building project. It allows water to drain naturally into the surface, reducing storm water runoff and its contaminant's from entering our waterways.

\*Available by special order only.



Left and Above: Permeable Mission pavers in Positano

### COLORS

\*Permeable Mission pavers are available by special order only.



Positano



Venice



# PERMEABLE COBBLESTONE\*

Permeable Paving Stones

Permeable Cobblestone pavers combine the look and feel of old, Roman-style cobbled block, with environmental benefits. Due to a unique spacer design, this paver allows storm water to drain naturally into the surface, reducing contaminant's and helping to preserve our waterways.

*\*Available by special order only.*



Right and Above: Permeable Cobblestone pavers in Positano



# SF RIMA™\*

Permeable Paving Stones

SF Rima™ permeable pavers are designed with the environment in mind, by reducing storm water runoff, decrease flooding and relieving storm water systems. SF Rima's unique design allows it to be installed with spacer-on-stone for water drainage or spacer-on-spacer for turf growth.

*\*Available by special order only.*



Left and Above: SF Rima pavers in Tan Charcoal

### COLORS

*\*Permeable Cobblestone pavers are available by special order only.*



Positano

*Water is allowed to naturally drain into the surface through the voids in permeable pavers.*



*Replenish your groundwater with environmentally friendly permeable pavers.*

### COLORS

*\*SF Rima pavers are available by special order only.*

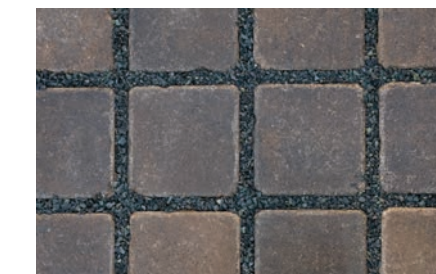

Tumbled Tan Charcoal (special order)

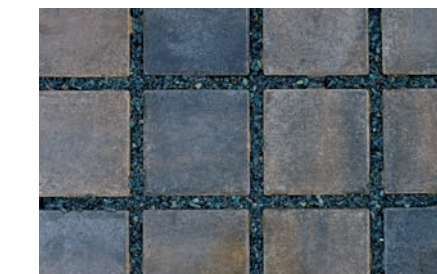

Tan Charcoal

NOTE: Printed colors shown in this brochure may vary from actual product colors. We recommend selecting colors from actual product samples. Custom colors are available by special order - please contact your local dealer.

NOTE: Printed colors shown in this brochure may vary from actual product colors. We recommend selecting colors from actual product samples. Custom colors are available by special order - please contact your local dealer.



# STONEWALL® II

Patented in the US, Patents pending in Canada

## Freestanding and Retaining Wall

StoneWall® II is a six-piece, tumbled retaining wall system. StoneWall II is a versatile system that can be installed in different patterns and can transition to a freestanding wall using the same stones.



Right and above: StoneWall II in Positano



**New!**  
Simons Column Caps Available in 24" and 30".



# STONEWALL® II

Patented in the US, Patents pending in Canada

## Freestanding Column Kit

Basalite's StoneWall II column kits are the perfect way to accent your freestanding wall with beautiful end columns. Don't forget to add that finishing touch with a Simons column cap.



Left and Above: StoneWall II Column Kit in Positano with optional Simons Column Cap in Charcoal

### COLORS



Positano Venice Sienna Milan Naples Tan Blend Grey Blend

NOTE: Printed colors shown in this brochure may vary from actual product colors. We recommend selecting colors from actual product samples. Custom colors are available by special order - please contact your local dealer.

### COLORS



Positano Venice Sienna Milan Naples Tan Blend Grey Blend

NOTE: Printed colors shown in this brochure may vary from actual product colors. We recommend selecting colors from actual product samples. Custom colors are available by special order - please contact your local dealer.



## BAYFIELD® Retaining Wall System

The Bayfield® Retaining Wall System combines earthen tones, rich textures and varied contours, making it a reliable alternative to natural stone walls. Use Bayfield® retaining walls to create stunning retaining and terraced walls.



Right and Above: Bayfield® retaining wall in custom color



## BAYFIELD® Freestanding Wall System

The Bayfield® Freestanding Wall System combine earthen tones, rich textures and varied contours, making it a reliable alternative to natural stone walls. Use Bayfield® freestanding walls to create stunning seating areas, borders, columns and courtyards.



Left and Above: Bayfield® freestanding wall in custom color

### COLORS



Positano



Venice

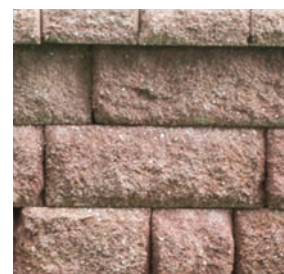

Sienna



Gray/Charcoal

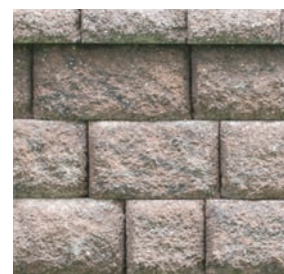

Tan/Brown



Venice/Positano



Positano



Venice

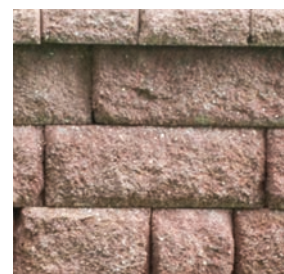

Sienna



Gray/Charcoal

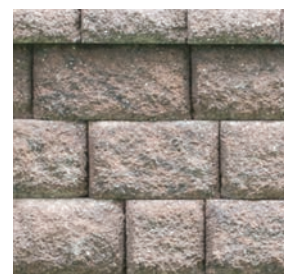

Tan/Brown



Venice/Positano

### COLORS



## ESTATE WALL

Retaining Wall

The unique artistry of your hardscape will be enhanced by our Estate wall. Estate wall offers the appearance and craftsmanship of hand-laid stone - but with the added advantages of segmental wall construction and design.



## necessaries™ OUTDOOR LIVING KITS

Necessaries™ Outdoor Living Kits is a collection of affordable, ready-to-assemble outdoor fireplaces, waterfalls, bars, tables, fire pits, pillars, seat walls and patio kits. Each kit comes with everything you need to build! See pages 5-8 for additional installation photos and pages 35-38 for kit specifications.

Left and Above: Colonial Fireplace Kit in Santa Fe and Compact Compact Waterfall Kit in Bluestone



Right: Estate Wall Tri-Plane Face in Tan  
Above: Estate Wall Straight Face in Positano



**COLORS** \* Colors available in Straight Face only. \*\* Colors available in Tri-Plane Face only.



Positano\* Venice\* Sienna\* Naples\* Tan\*\* Grey\*\* Tan-Charcoal\*\* Red-Charcoal\*\*

NOTE: Printed colors shown in this brochure may vary from actual product colors. We recommend selecting colors from actual product samples. Custom colors are available by special order - please contact your local dealer.

**COLORS**



Positano Santa Fe Desert Bluestone

NOTE: Printed colors shown in this brochure may vary from actual product colors. We recommend selecting colors from actual product samples. Custom colors are available by special order - please contact your local dealer.



## necessaries<sup>®</sup> ACCESSORIES

Customize, add additional functionality, and protect your investment with these accessories.



Right and Above: E-Z Access Spark and Grand Fire Ring Cap



**Grand Fire Ring Cap**  
10"W x 2-1/4"H (32"ID/52"OD).  
Silver Creek chiseled edge in limestone.  
Eight pieces per pallet. Approximate weight 31 lbs. Sold in full pallets only.

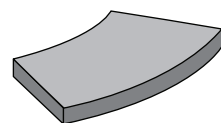

**E-Z Access Spark Screen**  
40" W x 18" H. Approximate weight 22 lbs.

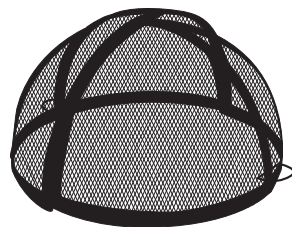

**Steel Fire Ring Cover**  
Prevents dirt and debris from entering the fire pit when not in use, keeping your ring ready for it's next use.

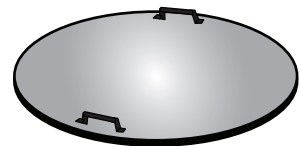

**Steel Fire Ring Cover For Units With A Grate**  
Specially modified for compatability with cooking grate version of the fire ring. Prevents dirt and debris from entering the fire pit when not in use, keeping your ring ready for it's next use.  
Grate not included with cover.

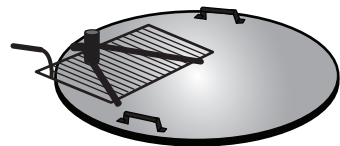

## ACCESSORY ITEMS



### Sakrete<sup>®</sup> Paver Set<sup>®</sup> Polymeric Sand

Sakrete Paver Set Polymeric Sand is a mixture of sand and special additives for paving stone joints. Engineered to resist wind, rain, freezing conditions and substratemovement without washing away. Available in a 60 lb bag.



### GST Low Sheen Wet Look Lacquer Sealer

GST Low Sheen Lacquer Sealer is a solvent-based, low sheen, crystal clear, deep penetrating sealer designed for decorative concrete, paving stone and natural stone surfaces, to enhance and beautify their natural color.



### Hardscape Zone Adhesive

Hardscape Zone Adhesive is the strongest adhesive of its kind. It is formulated for retaining walls, pavers, block, masonry, concrete, aluminum, steel and most common landscaping materials. Available in 10 oz and 28 oz tubes.



### Aluminum Paver Restraints and Landscape Spikes

StructurEdge™ is a permanent, aluminum paving restraint system that is designed to out-perform plastic, PVC and steel systems. Its tightfitting L-shaped design promotes healthy turf and accommodates irrigation heads. StructurEdge readily forms to curves, radii and angles, as well as straight lines, allowing wide installation flexibility.



## SPECIFICATIONS

## Italian Renaissance Pavers

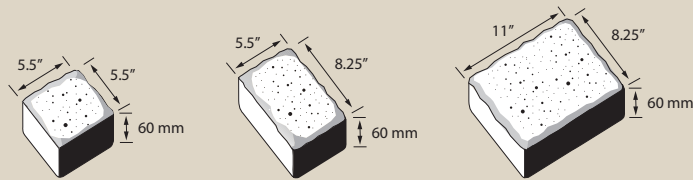

Shape: Square  
Weight: 6 lbs  
Units/Pallet: 512  
Sq. Ft./Pallet: 107

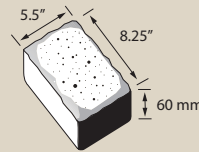

Shape: Rectangle  
Weight: 8 lbs  
Units/Pallet: 384  
Sq. Ft./Pallet: 121

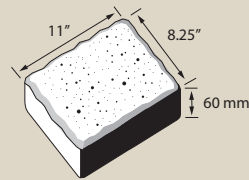

Shape: Mega  
Weight: 19 lbs  
Units/Pallet: 160  
Sq. Ft./Pallet: 102

## Artisan Flagstone Pavers

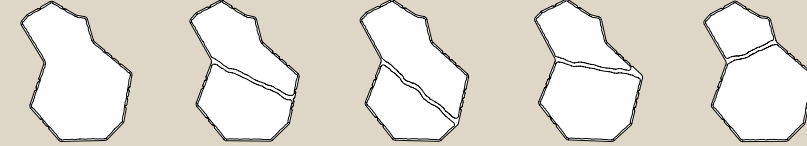

Thickness: 60 mm  
Weight: 23 lbs  
Units/Pallet: 100  
Sq. Ft./Pallet: 81  
20 pieces of Type 1, 2, 3, 4 and 5 units are on one pallet, for a full pallet quantity of 100 pieces.

## San Francisco Cobblestone Pavers

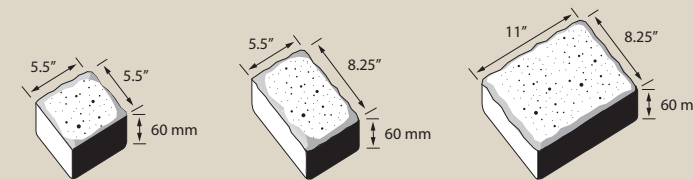

Shape: Square  
Weight: 6 lbs  
Units/Pallet: 512  
Sq. Ft./Pallet: 107

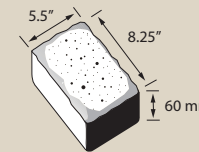

Shape: Rectangle  
Weight: 8 lbs  
Units/Pallet: 384  
Sq. Ft./Pallet: 121

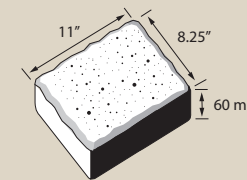

Shape: Mega  
Weight: 19 lbs  
Units/Pallet: 160  
Sq. Ft./Pallet: 102

## Permeable Italian Renaissance Pavers

Available by special order only.

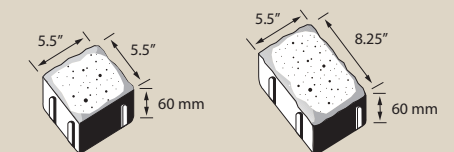

Shape: Square  
Weight: 6 lbs  
Units/Pallet: 512  
Sq. Ft./Pallet: 107

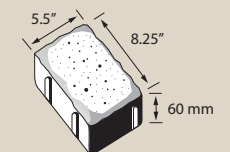

Shape: Rectangle  
Weight: 8 lbs  
Units/Pallet: 384  
Sq. Ft./Pallet: 121

## Artisan Slate Pavers

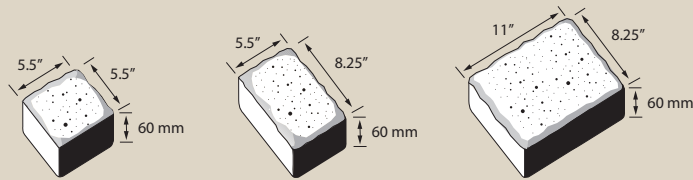

Shape: Square  
Weight: 6 lbs  
Units/Pallet: 512  
Sq. Ft./Pallet: 107

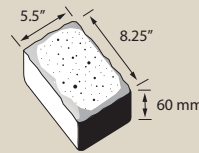

Shape: Rectangle  
Weight: 8 lbs  
Units/Pallet: 384  
Sq. Ft./Pallet: 121

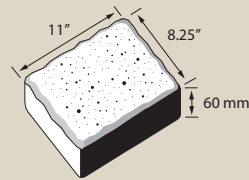

Shape: Mega  
Weight: 19 lbs  
Units/Pallet: 160  
Sq. Ft./Pallet: 102

## Heartland Pavers

Available by special order only. 24 pieces of "A", 32 pieces of "B", 24 pieces of "C" and 16 pieces of "D" units for a full pallet quantity of 96 pieces. Common cubed.

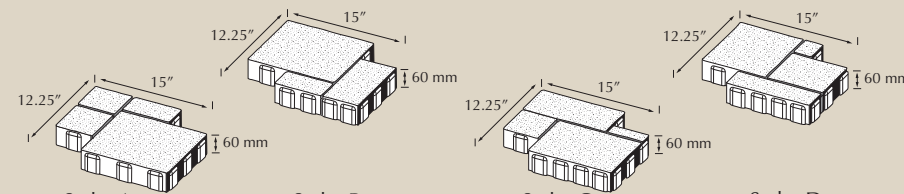

Style: A  
Weight: 28 lbs  
Units/Pallet: 96  
Sq. Ft./Pallet: 104

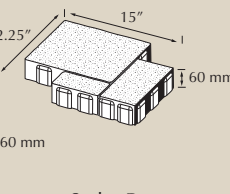

Style: B  
Weight: 28 lbs  
Units/Pallet: 96  
Sq. Ft./Pallet: 104

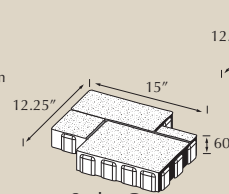

Style: C  
Weight: 28 lbs  
Units/Pallet: 96  
Sq. Ft./Pallet: 104

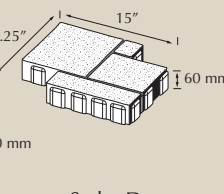

Style: D  
Weight: 28 lbs  
Units/Pallet: 96  
Sq. Ft./Pallet: 104

## Circle Kits

6 foot circle kit includes 1 piece of "A" Octagon, 8 pieces of "B" Sharp Wedges, 93 pieces of "C" Basic Wedges, 22 pieces of "D" Square and 33 pieces of "E" Rectangle units. 9 foot circle kit includes 1 piece of "A" Octagon, 8 pieces of "B" Sharp Wedges, 185 pieces of "C" Basic Wedges, 75 pieces of "D" Square and 73 pieces of "E" Rectangle units.

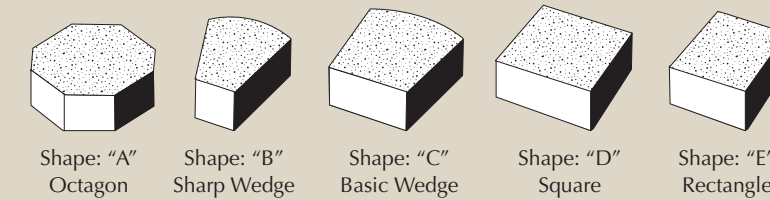

Shape: "A"  
Octagon  
Shape: "B"  
Sharp Wedge  
Shape: "C"  
Basic Wedge  
Shape: "D"  
Square  
Shape: "E"  
Rectangle

## Permeable Mission Pavers

Available by special order only.

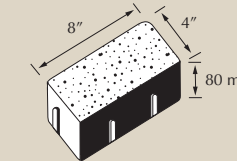

Weight: 9.5 lbs  
Units/Pallet: 307  
Sq. Ft./Pallet: 82.6

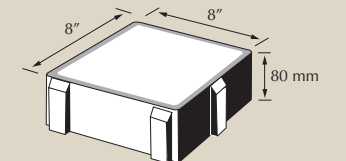

Weight: 17 lbs  
Units/Pallet: 180  
Sq. Ft./Pallet: 84

## Artisan Slate Premier Pavers

Available by special order only.

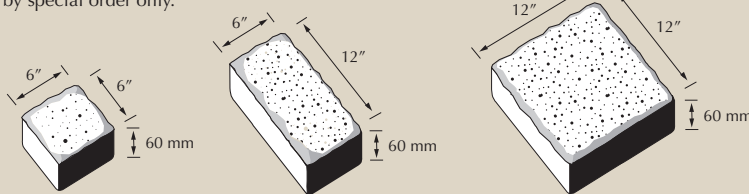

Style: 6x6  
Weight: 7 lbs  
Units/Pallet: 448  
Sq. Ft./Pallet: 108

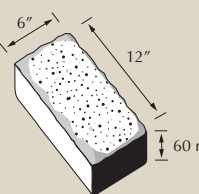

Style: 6x12  
Weight: 13.5 lbs  
Units/Pallet: 224  
Sq. Ft./Pallet: 108

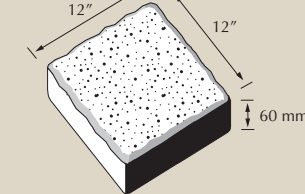

Style: 12x12  
Weight: 20 lbs  
Units/Pallet: 128  
Sq. Ft./Pallet: 122

## Country Cobble Pavers

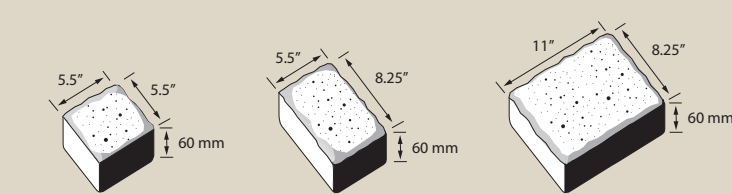

Shape: Square  
Weight: 6 lbs  
Units/Pallet: 512  
Sq. Ft./Pallet: 107

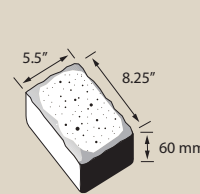

Shape: Rectangle  
Weight: 8 lbs  
Units/Pallet: 384  
Sq. Ft./Pallet: 121

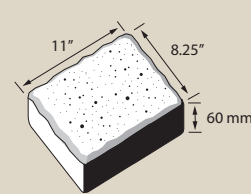

Shape: Mega  
Weight: 19 lbs  
Units/Pallet: 160  
Sq. Ft./Pallet: 102

## Bullnose Pavers

Has mortar groove for wet set applications.

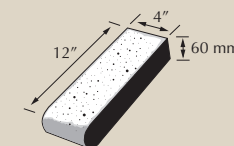

Weight: 8 lbs  
Units/Pallet: 256  
Sq. Ft./Pallet: 85

## Mission Pavers

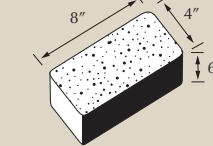

Weight: 7 lbs  
Units/Pallet: 528  
Sq. Ft./Pallet: 113

## Permeable Cobblestone Pavers

Available by special order only. Palletized common at 65 square feet to a pallet.

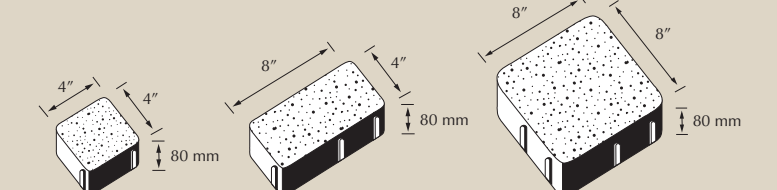

Shape: 4x4  
Weight: 3.45 lbs  
Units/Pallet: 168

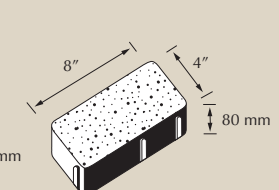

Shape: 4x8  
Weight: 6.75 lbs  
Units/Pallet: 96

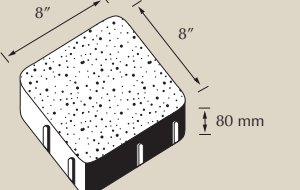

Shape: 8x8  
Weight: 15.5 lbs  
Units/Pallet: 72

# SPECIFICATIONS

## Bayfield® Retaining Wall

24 pieces of Large, Medium and Small units are on one pallet, for a full pallet quantity of 72 pieces. With a total of 36 sq. ft. on each retaining wall pallet. \*\*Cap units are palletized and sold separately. Standardized engineering is available.

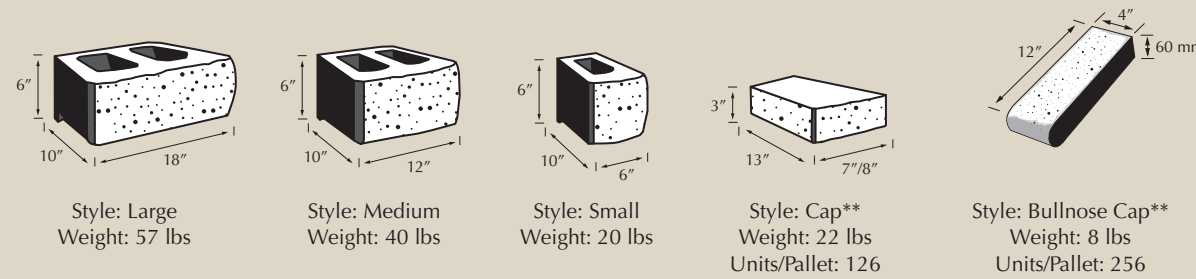

## Bayfield® Freestanding Wall

24 pieces of Large, Medium and Small units are on one pallet, for a full pallet quantity of 72 pieces. With a total of 33 sq. ft. on each freestanding wall pallet. The Bayfield freestanding units have textured sides for ending walls and incorporating columns without cutting. \*\*Column units and caps are palletized and sold separately.

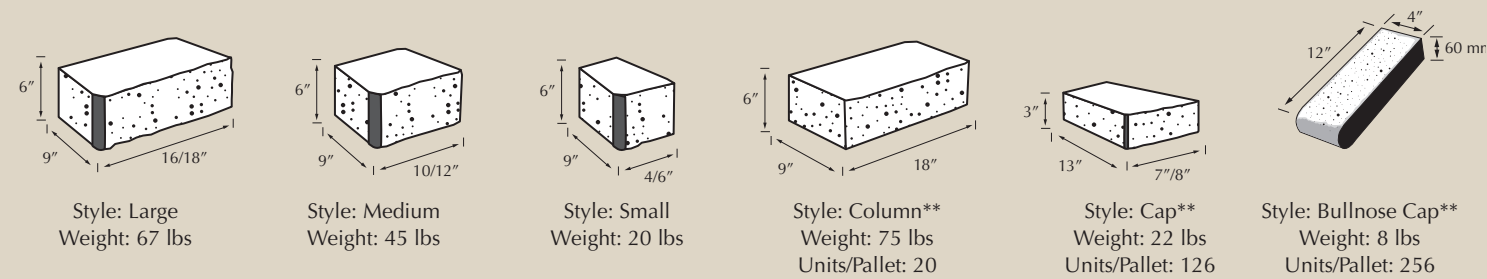

# SPECIFICATIONS

## StoneWall® II

StoneWall II is sold in pallet quantities only, with an average of 33 sq. ft. per pallet. There are six (6) different unit sizes randomly placed on each pallet.

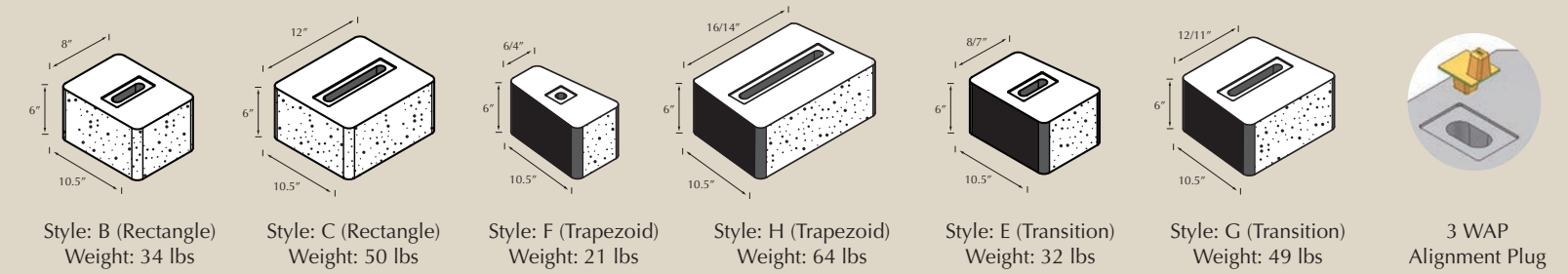

## StoneWall® II Column Kit

Each column is 21" x 21" square. There are 24 pieces of each sized block on the pallet for a total of 48 blocks. The kit will make two (2), 3-foot tall columns.

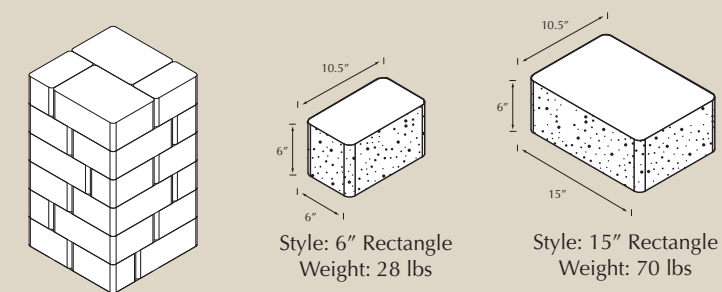

## Estate Wall

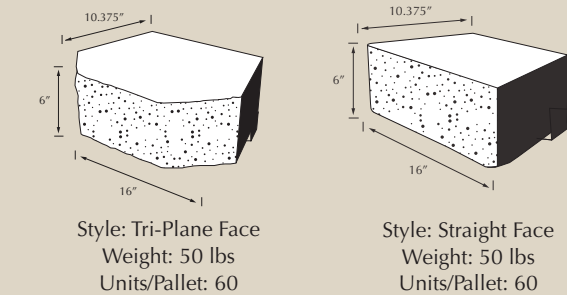

## SPECIFICATIONS

**Grand Fireplace Kit**

Kit includes: pre-cut block, instructions, Lennox Hearth Products 36" stainless steel wood-burning insert, 4' stainless steel stovepipe chimney and spark suppressor cap, steel reinforcements and adhesive. Weight: 9667 lbs.

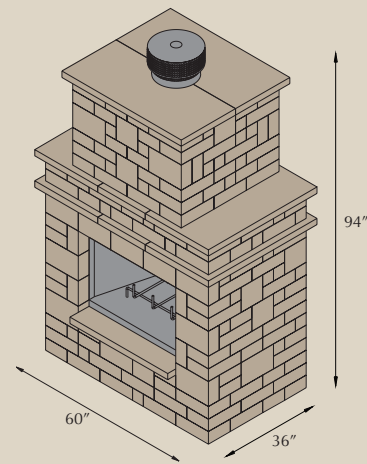
**Grand Wood Box Kit**

Kit includes: pre-cut block, instructions, steel reinforcements and adhesive. Available left or right side. Weight: 4051 lbs

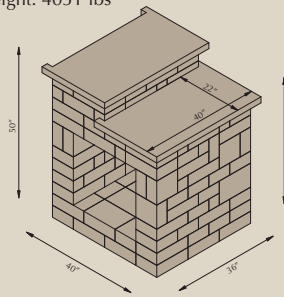
**Grand Hearth Kit**

Kit includes: pre-cut block, instructions and adhesive. Weight: 699 lbs

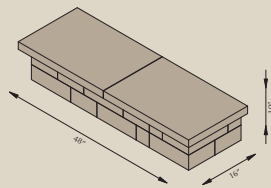
**Colonial Fireplace Kit**

Kit includes: pre-cut block, instructions, protective fire brick, steel reinforcements and adhesive. Weight: 3725 lbs.

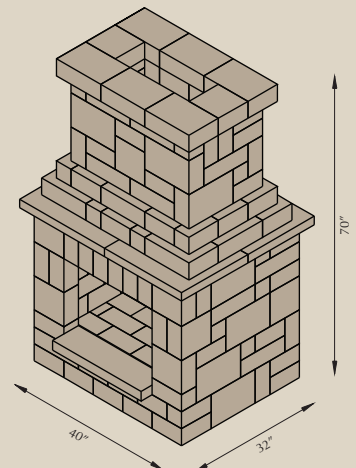
**Colonial Wood Box Kit**

Kit includes: pre-cut block, instructions and adhesive. Available left or right side. Weight: 1655 lbs

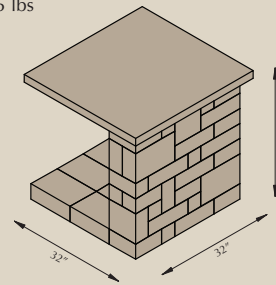
**Colonial Hearth Kit**

Kit includes: pre-cut block, instructions and adhesive. Weight: 285 lbs

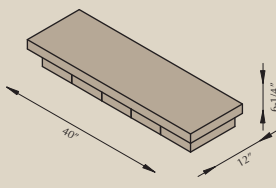
**Compact Fireplace Kit**

Kit includes: pre-cut block, instructions, protective fire brick, steel reinforcements and adhesive. Weight: 3725 lbs.

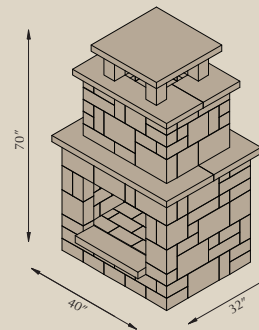
**Compact Wood Box Kit**

Kit includes: pre-cut block, instructions and adhesive. Available left or right side. Weight: 1655 lbs

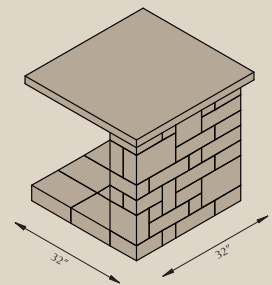
**Compact Hearth Kit**

Kit includes: pre-cut block, instructions and adhesive. Weight: 285 lbs

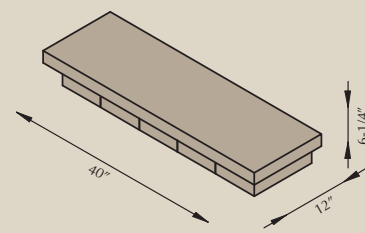

## SPECIFICATIONS

**Compact Fire Pit Kit With Grate**

Kit includes: heavy duty, ADA compliant steel grate, heavy gauge, solid steel ring insert, precut block, adhesive, gloves and instructions. Weight: lbs

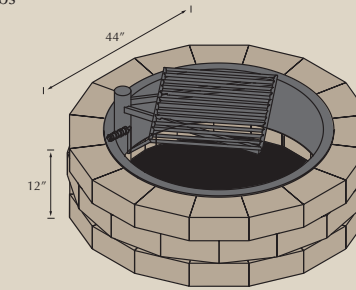
**Compact Fire Pit Kit With Ring**

Kit includes: heavy gauge, solid steel ring insert, precut block, adhesive, gloves and instructions.

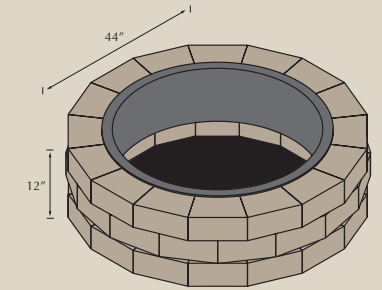
**Grand Fire Pit Kit With Grate**

Kit includes: heavy duty, ADA compliant steel grate, heavy gauge, solid steel ring insert, precut block, adhesive, gloves and instructions.

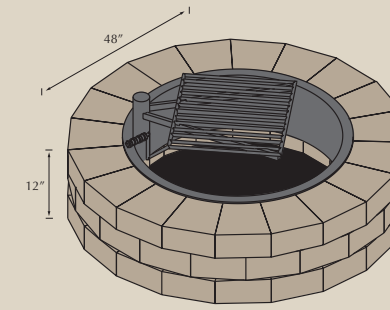
**Grand Fire Pit Kit With Ring**

Kit includes: heavy gauge, solid steel ring insert, precut block, adhesive, gloves and instructions.

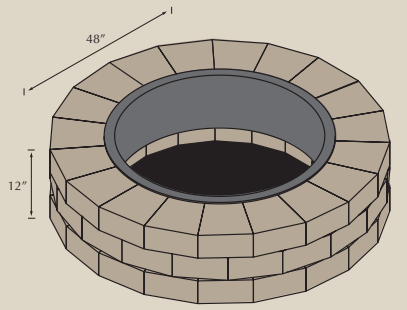
**Contemporary Fireplace Kit**

Kit includes: pre-cut block, instructions, Fire Gear, stainless steel gas burning insert, 43,000+ Btu's, 30" natural gas or LP burner, electronic ignition, on/off switch, stainless steel access door and adhesive. Weight: 4690 lbs.

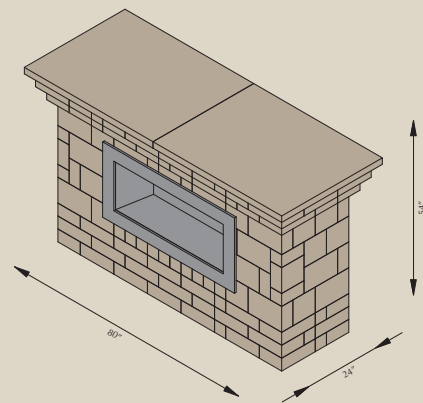
**Contemporary Wood Box Kit**

Kit includes: pre-cut block, instructions and adhesive. Weight: 699 lbs

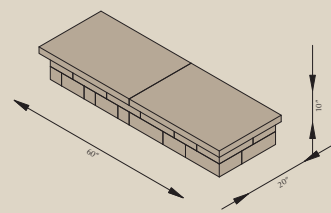
**Contemporary Hearth Kit**

Kit includes: pre-cut block, instructions and adhesive. Weight: 699 lbs

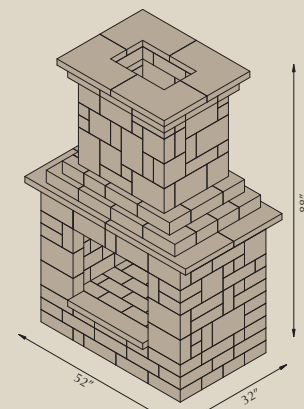
**Victorian Fireplace Kit**

Kit includes: pre-cut block, instructions, protective fire brick, steel reinforcements and adhesive. Weight: 4600 lbs.

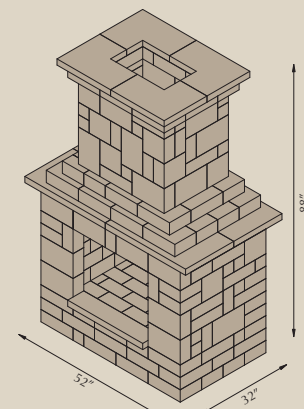
**Victorian Wood Box Kit**

Kit includes: pre-cut block, instructions and adhesive. Available left or right side. Weight: 2090 lbs

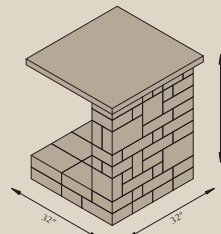
**Victorian Hearth Kit**

Kit includes: pre-cut block, instructions and adhesive. Weight: 699 lbs

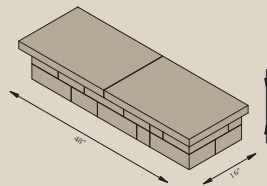
**Victorian Fire Pit Kit With Grate**

Kit includes: heavy duty, ADA compliant steel grate, heavy gauge, solid steel insert, precut block, adhesive, gloves and instructions.

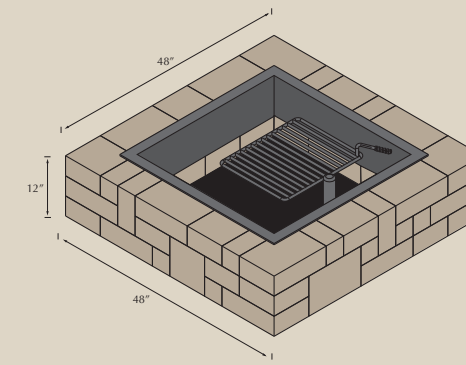
**Victorian Fire Pit Kit With Ring**

Kit includes: heavy gauge, solid steel insert, precut block, adhesive, gloves and instructions.

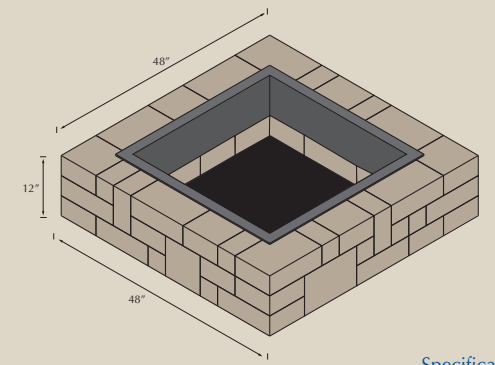

## SPECIFICATIONS

## Grand 8' Bar With Grill &amp; Refrigerator Opening

Kit includes: pre-cut block, instructions, Vermont Castings signature series 324 stainless gas grill (built-in), 24" W x 16" H stainless steel door with storage, steel reinforcements and adhesive. Weight: 7331 lbs.

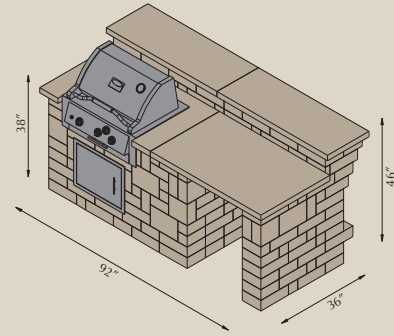

## Grand 8' Bar With Grill &amp; Door

Kit includes: pre-cut block, instructions, Vermont Castings signature series 324 stainless gas grill (built-in), 24" W x 24" H stainless steel door with storage, steel reinforcements and adhesive. Weight: 7331 lbs.

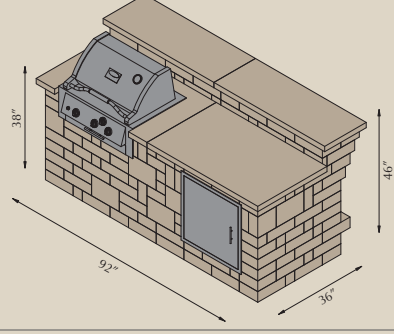

## Grand 8' Island Bar

Kit includes: pre-cut block, instructions, steel reinforcements and adhesive. Weight: 4905 lbs.

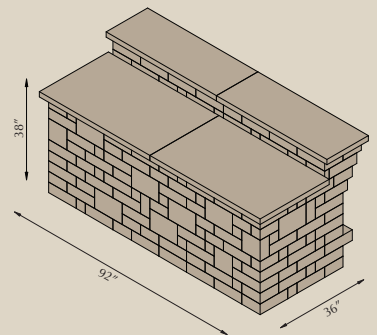

## Grand Corner Return

Kit includes: pre-cut block, instructions, steel reinforcements and adhesive. Weight: 5130 lbs.

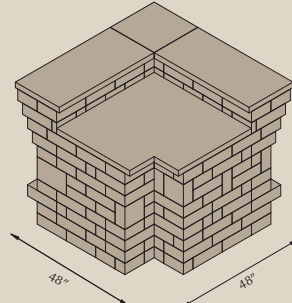

## Grand 4' Bar

Kit includes: pre-cut block, instructions, steel reinforcements and adhesive. Weight: 3770 lbs.

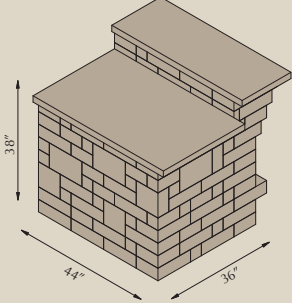

## Grand Grill Surround

Kit includes: pre-cut block, instructions, steel reinforcements and adhesive. Weight: 4905 lbs.

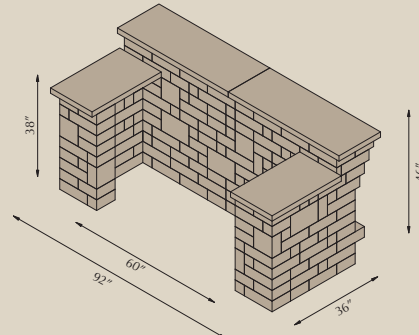

## Compact Bar with Grill

Kit includes: pre-cut block, instructions, Ultra Chef stainless/cast iron, three burner 59,000 BTU grill with infrared rear rotisserie burner and 570 sq. in. cooking area, steel reinforcements, adhesive. Weight: 2070 lbs.

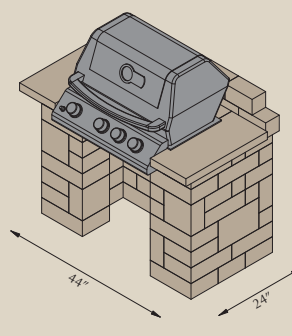

## Compact Bar Front Open

Kit includes: pre-cut block, instructions and adhesive. Weight: 2820 lbs.

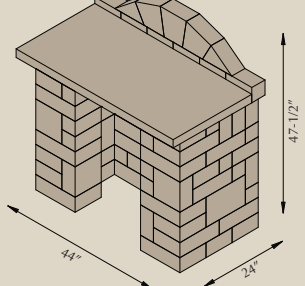

## Compact Bar Front Closed

Kit includes: pre-cut block, instructions and adhesive. Weight: 2820 lbs.

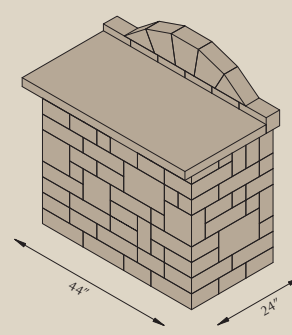

## Dining Table

Kit includes: pre-cut block, instructions, steel reinforcements and adhesive. Weight: 2860 lbs.

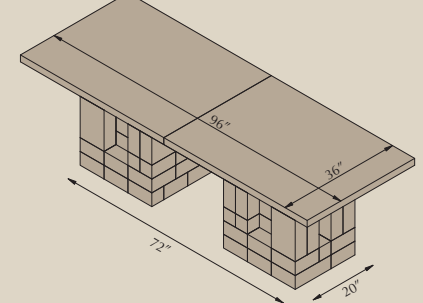

## Pub Table

Kit includes: pre-cut block, 36" octagon limestone table top, instructions and adhesive. Weight: 1505 lbs.

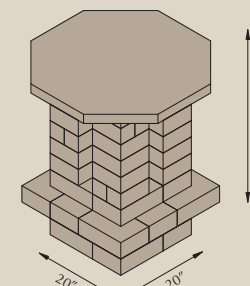

## Bistro Table

Kit includes: pre-cut block, 36" octagon limestone table top, instructions and adhesive. Weight: 1505 lbs.

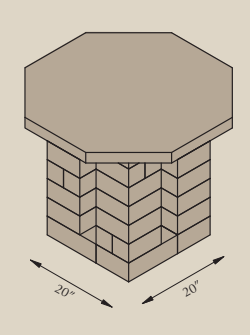

## SPECIFICATIONS

## Grand Waterfall

Kit includes: pre-cut block, instructions, 1350 gph mag drive pump, 48" square basin and all connections, 23" stainless steel spillway, steel reinforcements, adhesive and gloves. Weight: 3465 lbs.

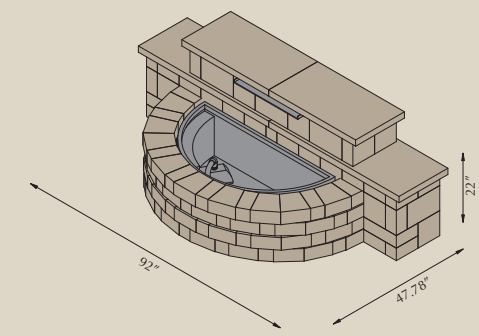

## Compact Waterfall

Kit includes: pre-cut block, instructions, 850 gph mag drive pump, 26" square basin, 11" stainless steel spillway, steel reinforcements, adhesive and gloves. Weight: 1650 lbs.

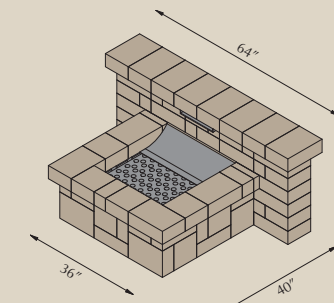

## 20 inch Column with Glass

Kit includes: pre-cut block, instructions, adhesive and Pittsburgh Corning® Premiere glass block. Weight: 1140 lbs.

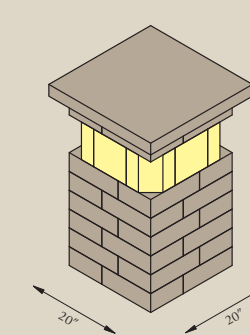

## 20 inch Column

Kit includes: pre-cut block, instructions and adhesive. Weight: 1250 lbs.

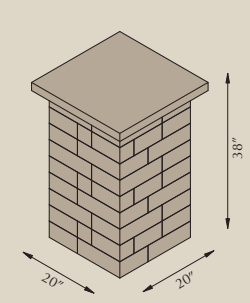

## 24 inch Column

Kit includes: pre-cut block, instructions and adhesive. Weight: 1655 lbs.

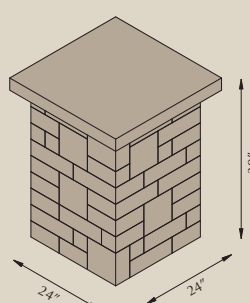

## Lakeland Seatwall

Kit includes: pre-cut block, instructions and adhesive. Weight: 1060 lbs.

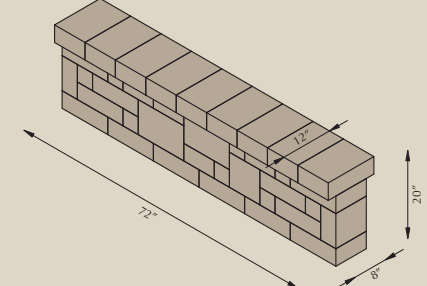

## Riverland Seatwall

Kit includes: pre-cut block, instructions and adhesive. Weight: 1390 lbs.

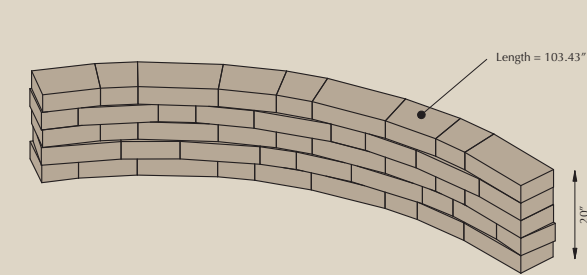

# PATTERNS

The following paver patterns are just a few possibilities that can be achieved by using Basalite pavers. Visit [www.basalite.com](http://www.basalite.com) for more pattern options.

## Interlace

70% rectangle and 30% square

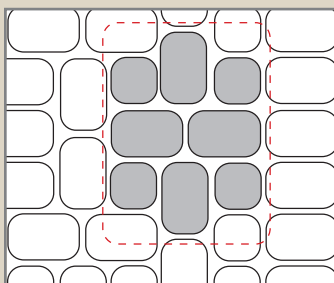

For use with Italian Renaissance, Country Cobble, San Francisco Cobblestone and Permeable Italian Renaissance pavers.

## Random One

40% mega, 20% rectangle and 40% square

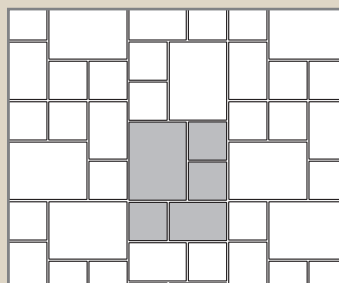

For use with Italian Renaissance, Country Cobble, San Francisco Cobblestone and Artisan Slate pavers.

## Random Two

29% Mega, 42% rectangle and 29% square

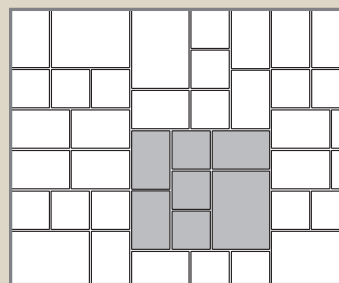

For use with Italian Renaissance, Country Cobble, San Francisco Cobblestone and Artisan Slate pavers.

## Herringbone

100% rectangle

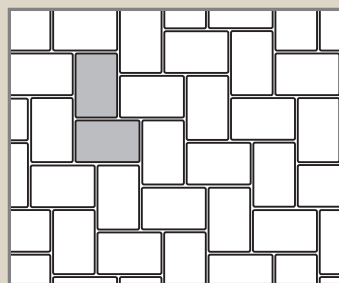

For use with Italian Renaissance, Country Cobble, San Francisco Cobblestone, Artisan Slate Premier Series, Mission and Permeable Italian Renaissance pavers.

## Heartland



For use with Heartland pavers.

## Herringbone Flagstone

37.5% Mega, 37.5% rectangle and 25% square

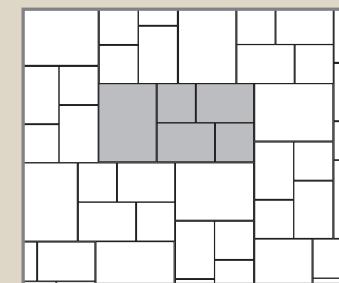

For use with Artisan Slate pavers.

## Water Drainage

Spacer on stone

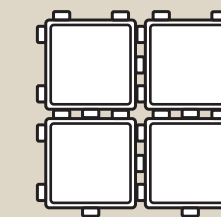

For use with SF Rima.

## Turf Growth

Spacer on spacer

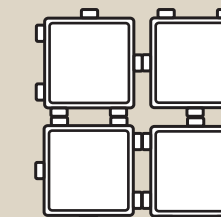

## Square Running Bond

100% square

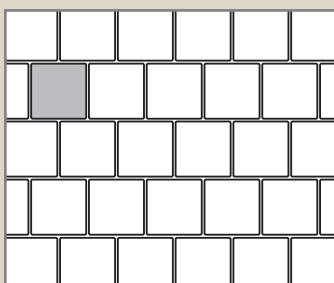

For use with Italian Renaissance, Country Cobble, San Francisco Cobblestone, Artisan Slate Premier Series and Permeable Italian Renaissance pavers.

## Rectangle Running Bond

100% rectangle

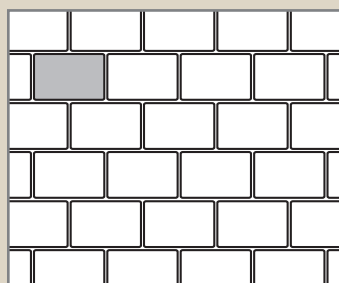

For use with Italian Renaissance, Country Cobble, San Francisco Cobblestone, Artisan Slate Premier Series, Mission, Permeable Mission and Permeable Italian Renaissance pavers.

## Basket Weave

100% rectangle

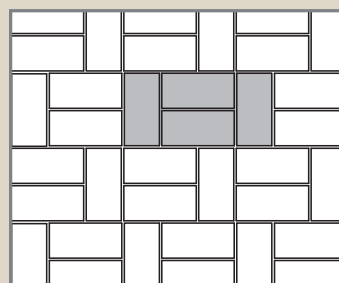

For use with Artisan Slate Premier Series and Mission paver.

## Double Basket Weave

100% rectangle

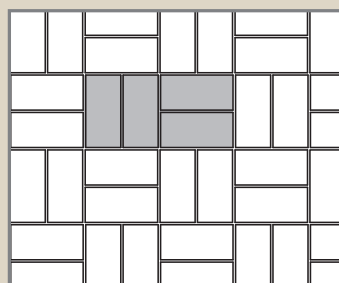

For use with Artisan Slate Premier Series and Mission paver.

## Flagstone

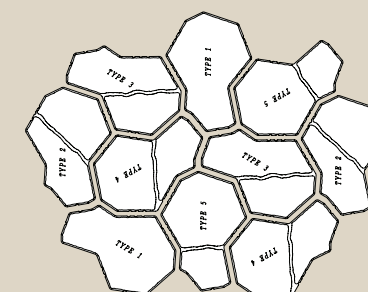

For use with Artisan Flagstone. Spacers and alignment grooves make installation easy.

## 6 Foot Circle Kit

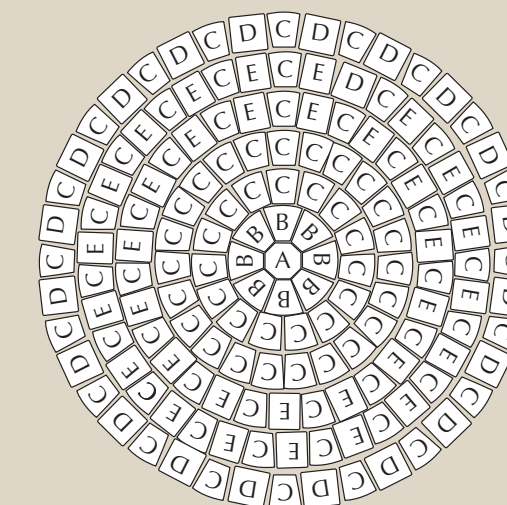

## 9 Foot Circle Kit

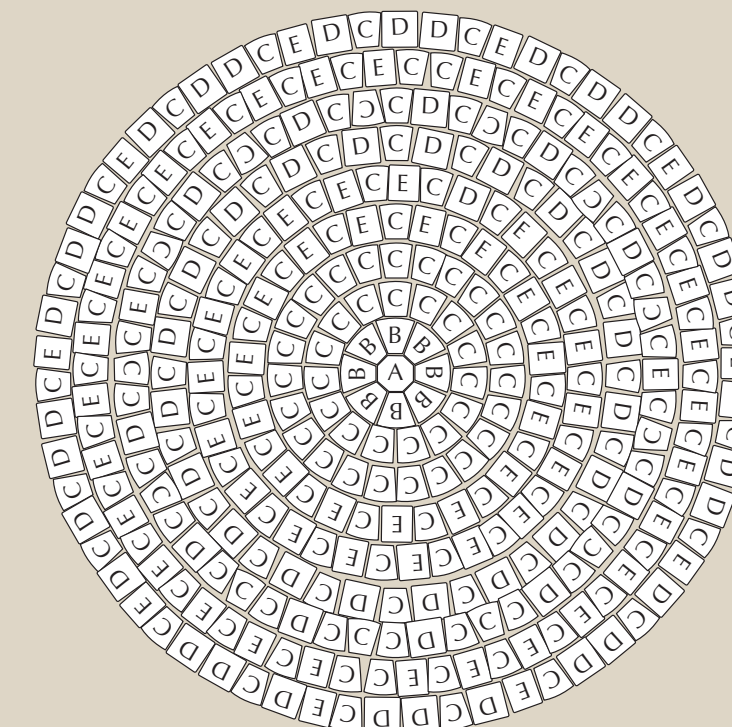

## Pinwheel

80% 6x12 and 20% 6x6

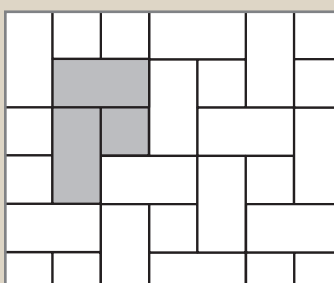

For use with Artisan Slate Premier Series pavers.

## Blend

60% 12x12 and 40% 6x12

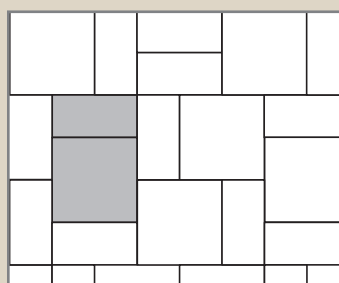

For use with Artisan Slate Premier Series pavers.

## Plaid

45% 12x12, 45% 6x12 and 10% 6x6

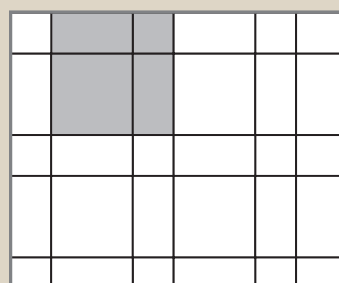

For use with Artisan Slate Premier Series pavers.

## Herringbone Blend

66% 6x12 and 34% 6x6

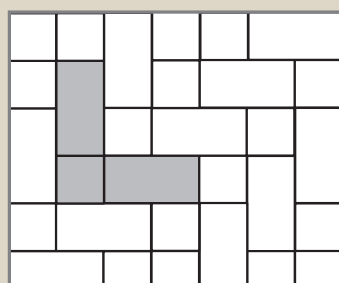

For use with Artisan Slate Premier Series pavers.

# PATTERNS

# INSTALLATION INSTRUCTIONS

\*The installation instructions and illustrations shown are a basic overview of paver and wall installation methods. Because installation methods vary per product, please refer to the Basalite product specific installation guide, the Standard ICPI installation method, ICPI.org or visit [www.basalite.com](http://www.basalite.com).

## Typical Paver Installation\*

1. Excavate unsuitable, unstable or unconsolidated subgrade material and compact the area which has been cleared. Backfill and level with dense graded aggregate suitable for base material (typically 3"-6" for pedestrian/light vehicular traffic and 8"-10" for driveway applications), or as otherwise directed by site engineer/architect/landscape architect.
2. Install edge restraint using concrete curb, concrete toe or edging.
3. Place bedding course of sharp, normal-weight screening or concrete sand to a uniform depth of approximately 1" leveled to grade.
4. Install Basalite Pavers hand tight with joints approximately 1/8". Where required, cut stones with an approved cutter to fit accurately.
5. Tamp pavers with mechanical vibrator, uniformly level, true to grade and free of movement. Textured pavers require a rubber pad for the vibrator to reduce scuffing.
6. Fill voids in joints by sweeping dry, fine, sharp sand over pavers.

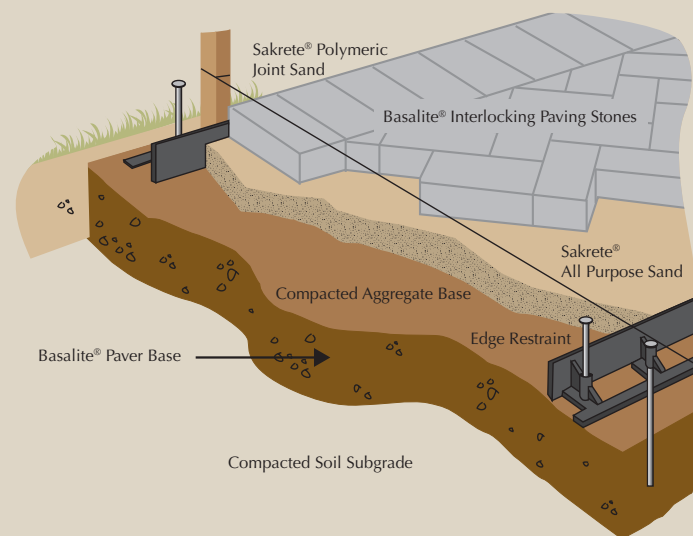

## Permeable Paver Installation\*

1. Excavate unsuitable, unstable or unconsolidated subgrade material and compact the area in accordance to ICPI guidelines. Backfill and level Sub-base with No. 2 aggregate 2-1/2" crushed. Backfill and level base layer with No. 57 aggregate 3/4" crushed. The joint material and the foundation (paver bed, subbase, subgrade) must be permeable. 60mm thick pavers may be used in pedestrian applications.
2. Install edge restraint using concrete curb, concrete toe or edging.
3. Place bedding course of No. 8 aggregate 3/8" leveled to grade.
4. Install Pavers in closed assembly with spacer on stone for water drainage. Fill joints with gravel. Where required, cut stones with an approved cutter to fit accurately.
5. Tamp pavers with mechanical vibrator, uniformly level, true to grade and free of movement. Textured pavers require a rubber pad for the vibrator to reduce scuffing.
6. Fill voids in joints by sweeping dry ASTM No. 8, 89 or 9 stones.

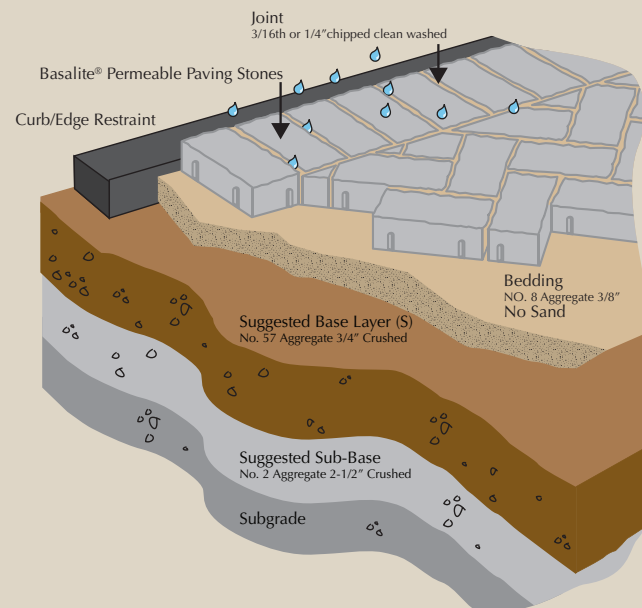

# INSTALLATION INSTRUCTIONS

\*The Bayfield Retaining Wall System can be used for gravity walls up to 3 feet high, including buried course, but excluding the cap. Taller walls can be built with the Retaining Wall System using geosynthetic reinforcement when designed by a qualified engineer. Height assumes level backfill and clean, compacted sand or gravel and no surcharge. The Bayfield® Freestanding Wall System can be used for walls up to 3 feet high, including buried course, but excluding the cap.

## Typical Retaining Wall Installation\*



**A. Prepare Base Leveling Pad**  
Excavate for the leveling pad. The trench should be at least 12 inches wider than the block you are installing and 6 inches deeper than the height of the block. Use a compactable base material of 3/4-inch minus (with fines) for the leveling pad. The pad must extend at least 6 inches in front of and behind the first course of block, and be at least 6 inches deep

after compaction. If the planned grade along the wall front will change elevation, the leveling pad may be stepped up in 6-inch increments to match the grade change. Start at the lowest level and work upward whenever possible. Compact the aggregate and make sure it's level front to back and side to side. Mist lightly with water before compaction.

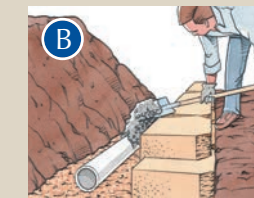

**B. Base Course**  
Begin laying block at the lowest elevation of the wall. For quick-leveling, use the Torpedo™ base block with the hand-holds down, or you can remove the rear lip of the block by hitting from the back so it will lie flat on the leveling pad. Place the first block level, front to back and side to side; lay subsequent blocks in the same manner, flush against each other.

Make sure they are in full contact with the leveling pad. If the wall is on an incline, don't slope the blocks; step them up so they remain consistently level. For multiple-piece products, use the largest unit, 18 inches wide, for the base course. Complete the base course before proceeding to the second course. A drainage pipe should be placed at rear base of first course.

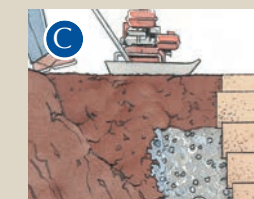

**C. Stacking and Fill**  
Place the second course of blocks on top of the base course. Remember to keep the wall on bond by placing units in a staggered relationship to the course beneath. Pull each block forward as far as possible to ensure the correct setback. Backfill with drainage aggregate directly behind the block, adding 6 inches at a time, followed by proper compaction. Add soil fill behind the aggregate. Compact before the next course is laid. With the top units dry and clean, stack the caps on top of the final row and use a masonry construction adhesive such as Hardscape Zone adhesive.

## StoneWall II Installation\*

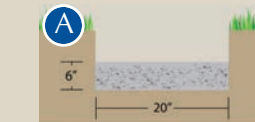

**A. Prepare Base Leveling Pad**  
Excavate trench 20" wide and 12" deep along the length of wall, assuring depth provides proper unit embedment. On sloped sites, step up 6" to change elevation. Place 6" of 3/4"-1/2" crushed aggregate in the trench. Level, then compact to 95% or greater of standard proctor.

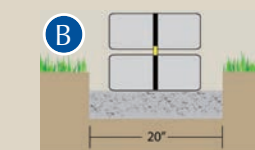

**B. Set & Align Base Course**  
Starting at lowest elevation, ideally a corner, place and level the block using a string line and 2' level. Follow the suggested patterns as shown, or create your own. Make sure the recess next to the center core is placed top up. Place alignment plugs into the center core following the guidelines below. Lay out the entire bottom course before proceeding to the next courses. Place perforated drain pipe onto leveling pad, behind base course (retaining wall) then backfill, 12" deep, to top of wall with crushed aggregate. Stack additional courses altering the pattern course to course. Repeat the steps to reach the desired wall.



**C. 3-Way Alignment Plug (3WAP)**  
After stacking the block course, place a 3WAP into the core of each unit, assuring that the flange on the plug rests within the recess adjacent to the core. Orient the plug to achieve your desired wall batter. Use the setback position for retaining walls to achieve a 7.3 degree batter, the vertical position for bench walls, and the reveal position to occasionally highlight a unit.

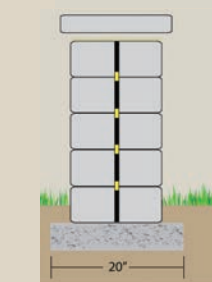

**D. Capping the Wall**  
Adhere clean and dry cap blocks to the wall using silicon concrete construction adhesive. Place cap flush to the wall face or with an overhang.