

BM



Needle Holders, Suture Instruments,
Ligature Needles, Guiding Probes
Portaagujas, instrumentos para sutura,
agujas para ligadura y sondas acanaladas

Needle Holders - Portaaguja

Micro Needle Holders with Flat Handles

Portaaguja con mangos planos para microcirugía

BM



BM563R

BM564R

1/2

CASTROVIEJO

BM563R-BM564R

with catch

con cierre

145 mm, 5 3/4"

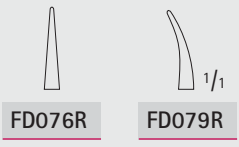

FD076R

FD079R

1/2

FD076R-FD079R

without catch

sin cierre

160 mm, 6 1/4"

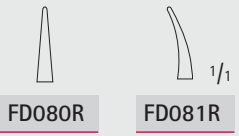
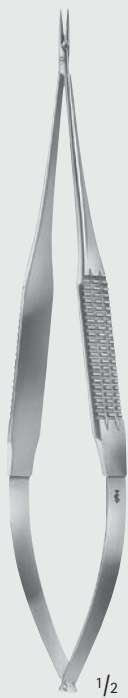

FD080R

FD081R

1/2

FD080R-FD081R

without catch

sin cierre

185 mm, 7 1/4"

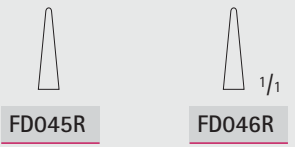

FD045R

FD046R

without catch

sin cierre

with catch

con cierre

1/2

JACOBSON

FD045R-FD046R

185 mm, 7 1/4"

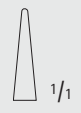

1/1

1/2

FD048R

with catch

con cierre

200 mm, 8"





Needle Holders – Portaagujas

Micro Needle Holders with Round Handles

Portaagujas con mangos redondos para microcirugía

BM

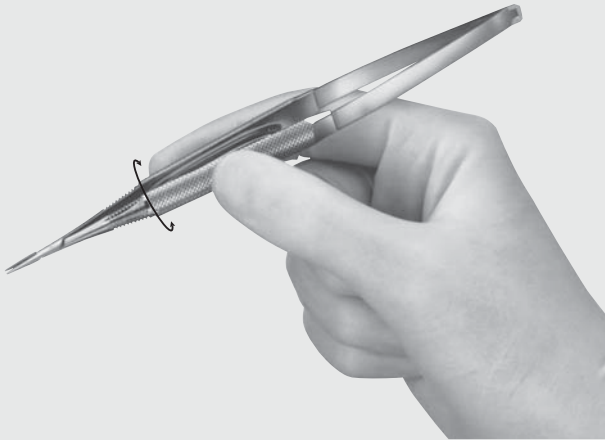

... with round handles

- Round handles allow turning manipulations between the fingers.
- Optimum balance individually for each instrument due to solid or hollowed-out handles.

... con mangos redondos

- Los mangos redondos permiten movimientos giratorios entre los dedos.
- Óptimo equilibrio individual para cada instrumento debido a mangos sólidos o huecos.

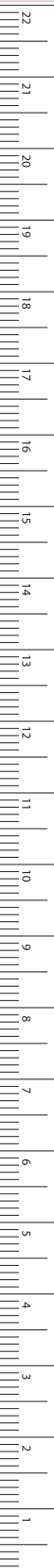

MILLIMETERS



BM560R	BM562R
115 mm	120 mm
4 1/2"	4 3/4"

BARRAQUER

BM560R-BM562R

without catch
sin cierre



FD230R	FD231R
--------	--------

BARRAQUER

FD230R-FD231R

without catch
sin cierre
120 mm, 4 3/4"



FD232R	FD233R
--------	--------

BARRAQUER

FD232R-FD233R

with catch
con cierre
120 mm, 4 3/4"

Needle Holders - Portaaguja

Micro Needle Holders with Round Handles

Portaaguja con mangos redondos para microcirugía

BM



FD240R

FD241R

REILL

FD240R-FD241R

without catch

sin cierre

150 mm, 6"



FD242R

FD243R

FD242R-FD243R

with catch

con cierre

150 mm, 6"

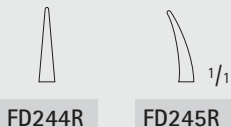

FD244R

FD245R

FD244R-FD245R

without catch

sin cierre

185 mm, 7 1/4"

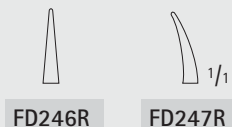

FD246R

FD247R

FD246R-FD247R

with catch

con cierre

185 mm, 7 1/4"

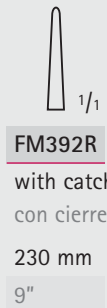

FM392R

with catch

con cierre

230 mm

9"

FM392R



Needle Holders – Portaagujas

Micro Needle Holders with Lightweight Plastic Handles
Portaagujas con mangos de plástico ligeras para microcirugía



The MÜLLER Micro instrument system

A top quality set for peripheral microsurgery. Numerous details tried and tested in practice mean increased efficiency and safety.

Natural holding position = increased sensitivity

- The light plastic profile increases the grip surface, thus guaranteeing a natural hand position without cramping and providing enhanced sensitivity.

Easier rotation = extended working area

- The round grip cross section permits easy and uniform rotation of the instrument. This extends the application and working areas.

Safe grip

- Optimum handling
- Development in accordance with ergonomic criteria and the low weight of the new plastic grips provide fatiguefree working and optimum handling.

El sistema de microinstrumentos de MÜLLER

Un juego de calidad superior para la microcirugía periférica. Numerosos detalles probados y examinados en la práctica llevan a una efectividad y seguridad elevada.

Posición natural de agarre = mayor sensibilidad

- El ligero perfil de plástico incrementa la superficie de agarre, garantizando así una posición natural de la mano libre de calambres y proporcionando mayor sensibilidad.

Rotación más fácil = área de trabajo ampliada

- El corte transversal redondo de la superficie de agarre permite una rotación sencilla y uniforme del instrumento. Esto amplía aplicaciones y áreas de trabajo.

Agarre seguro

- Manejo óptimo
- El desarrollo de acuerdo a criterios ergonómicos en combinación con el bajo peso de los mangos de plástico permite un trabajo sin fatiga y un manejo óptimo.

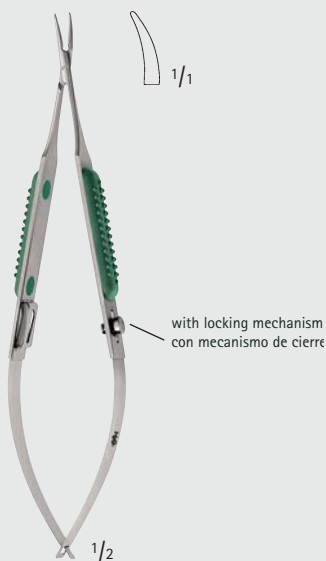

MÜLLER

FM021R

145 mm, 5 3/4"



MÜLLER

FM061R

180 mm, 7"

BM



MILLIMETERS

Needle Holders - Portaaguja

DUROGRIP® Micro Needle Holders

DUROGRIP® portaaguja para microcirugía

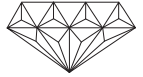

BM

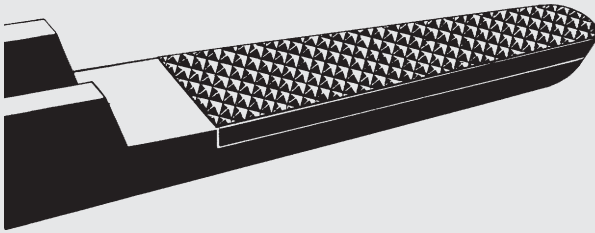

smooth
liso



0.2



0.4



0.5

Aesculap needle holders have jaws with carbide inserts and according to the use required the resp. structure can be chosen. A smooth jaw surface as well as 3 different serrations guarantee a sure „grip“ of the resp. needle.

Portaaguja Aesculap son adaptados a cada material de sutura conforme con la indicación por medio de la estructura de las distintas bocas de metal extraduro. La boca lisa y 3 distintos perfiles garantizan un agarre seguro de cada aguja.

We recommend carbide inserts with smooth jaw surface for suture material with 0.2 mm pitch of serration for suture material 0.4 mm 0.5 mm

9/0 – 11/0
6/0 – 10/0
4/0 – 6/0
up to 3/0

Recomendamos bocas de metal extraduro con superficie lisa para material de sutura con estructura 0,2 mm para material de sutura 0,4 mm 0,5 mm

9/0 – 11/0
6/0 – 10/0
4/0 – 6/0
hasta 3/0



DUROGRIP® Needle holders with carbide inserts

Identification:

■ gold-plated rings, handle ends and ratchets

Portaaguja DUROGRIP® con placas de metal extraduro

Identificación:

■ Anillos, ramas y cremalleras dorados



1/1
with smooth jaw
con boca lisa

1/2

CASTROVIEJO

BM001R

145 mm, 5 3/4"



1/1
0.2

1/2

CASTROVIEJO

BM002R

145 mm, 5 3/4"



1/1
0.4

1/2

BM003R

170 mm, 6 3/4"

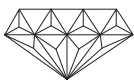

Needle Holders - Portaagujas
DUROGRIP® Micro Needle Holders
 DUROGRIP® portaagujas para microcirugía

BM



CASTROVIEJO

BM004R

180 mm, 7"



CASTROVIEJO

BM005R

215 mm, 8 1/2"



FM388R

with catch
con cierre
180 mm, 7"



FM390R

with catch
con cierre
200 mm, 8"

MILLIMETERS

DIA DUST®



Needle Holders - Portaaguja

DIA DUST® Micro Needle Holders with Round Handle

DIA DUST® portaaguja con mangos redondos para microcirugía

DIA DUST®



The diamond dust coating ensures an even harder and more wear resistant surface on the inside of the jaws. Moreover, the structure of the DIA DUST® coating guarantees a reliable grip for fine needles and sutures, as well as for tissue.

El recubrimiento de polvo de diamante asegura una superficie interior de la boca todavía más dura y más resistente al desgaste. La estructura del recubrimiento DIA DUST® además garantiza un agarre seguro de agujas finas y material de sutura así como tejido blando.

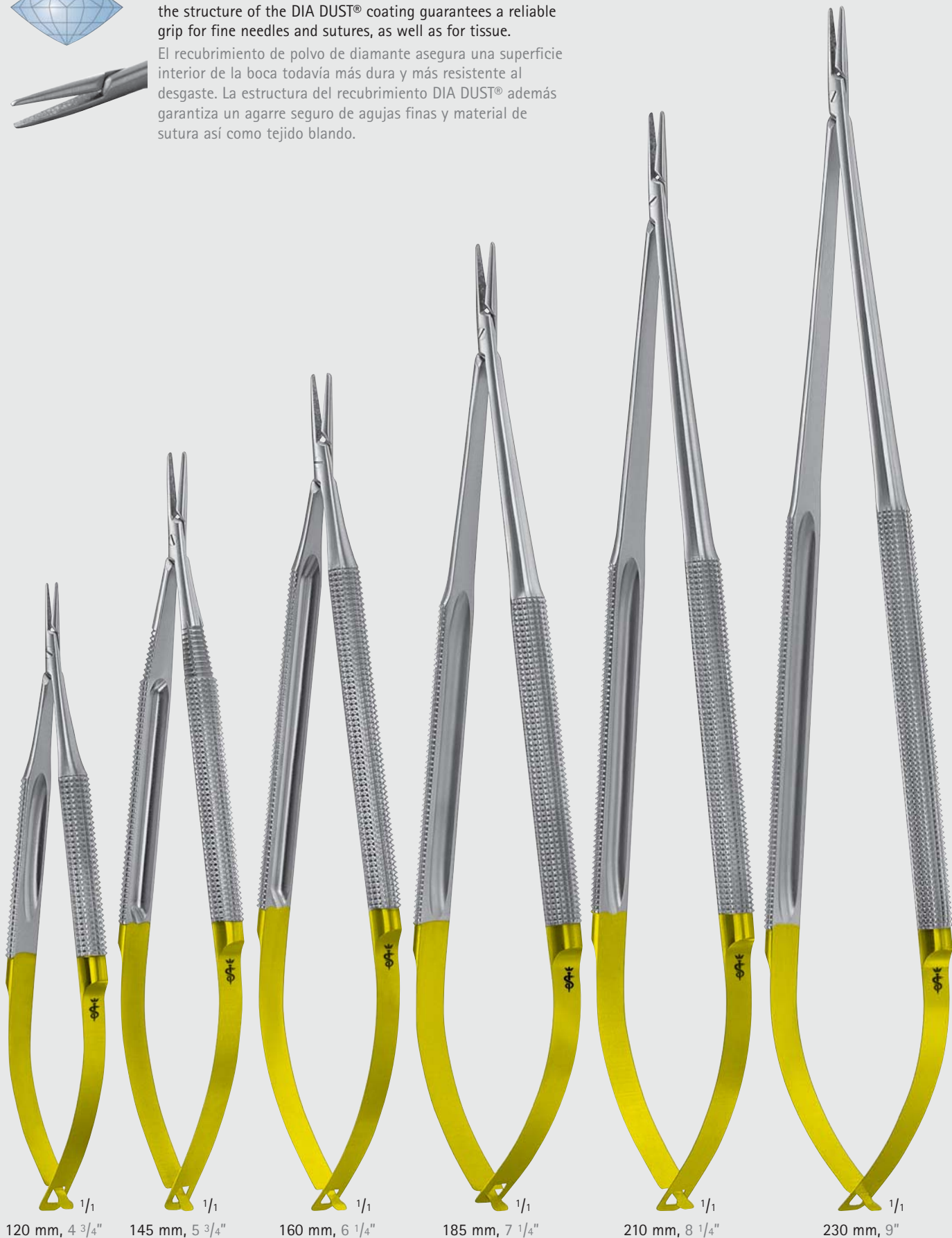

120 mm, 4 3/4" 1/1

145 mm, 5 3/4" 1/1

160 mm, 6 1/4" 1/1

185 mm, 7 1/4" 1/1

210 mm, 8 1/4" 1/1

230 mm, 9" 1/1

INCHES



DIA DUST®



Needle Holders – Portaaguja

DIA DUST® Micro Needle Holders with Round Handle

DIA DUST® portaaguja con mangos redondos para microcirugía



with catch
con cierre



Suture size

Medida del material de sutura

Length Longitud	7/0 and smaller 7/0 y más fino	5/0 and smaller 5/0 y más fino	4/0 and smaller 4/0 y más fino	4/0 and smaller 4/0 y más fino
120 mm 4 3/4"	FM520R			
145 mm 5 3/4"		FM522R		
160 mm 6 1/4"	FM521R	FM523R		
185 mm 7 1/4"	FM563R	FM564R	FM218R	
210 mm 8 1/4"	FM565R	FM566R	FM228R	FM221R
230 mm 9"	FM567R	FM568R	FM230R	FM223R

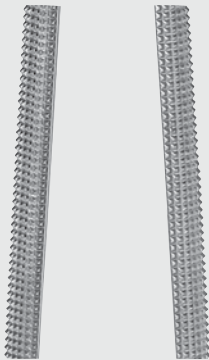

without catch
sin cierre



Suture size

Medida del material de sutura

Length Longitud	7/0 and smaller 7/0 y más fino	5/0 and smaller 5/0 y más fino
120 mm 4 3/4"	FM524R	
145 mm 5 3/4"		FM528R
160 mm 6 1/4"	FM525R	FM529R
185 mm 7 1/4"	FM526R	FM530R
210 mm 8 1/4"	FM527R	FM531R
230 mm 9"	FM532R	FM533R

BM



MILLIMETERS

Needle Holders - Portaaguja

DIA DUST® Micro Needle Holders with Round Handle

DIA DUST® Portaaguja con mangos redondos para microcirugía

DIA DUST®



The diamond dust coating ensures an even harder and more wear resistant surface on the inside of the jaws. Moreover, the structure of the DIA DUST® coating guarantees a reliable grip for fine needles and sutures, as well as for tissue.

El recubrimiento de polvo de diamante asegura una superficie interior de la boca todavía más dura y más resistente al desgaste. La estructura del recubrimiento DIA DUST® además garantiza un agarre seguro de agujas finas y material de sutura así como tejido blando.



190 mm, 7 1/2"

230 mm, 9"

250 mm, 10"

BM

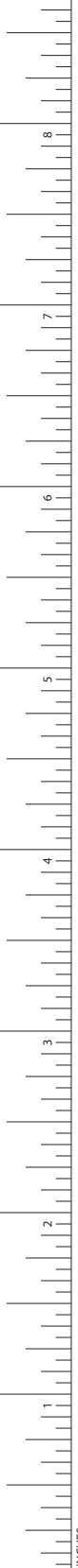



DIA DUST®

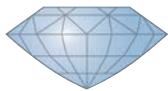

Needle Holders – Portaagujas

DIA DUST® Micro Needle Holders with Round Handle

DIA DUST® portaagujas con mangos redondos para microcirugía

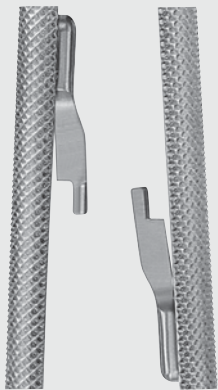

with catch,
heavy style
con cierre,
modelo fuerte



Suture size
Medida del
material de sutura

Length Longitud	2/0 and smaller 2/0 y más fino
190 mm 7 1/2"	<u>FM538R</u>
230 mm 9"	<u>FM539R</u>
250 mm 10"	<u>FM534R</u>

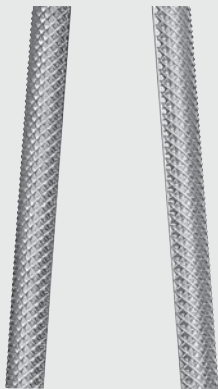

with catch,
heavy style
con cierre,
modelo fuerte



Suture size
Medida del
material de sutura

Length Longitud	2/0 and smaller 2/0 y más fino
190 mm 7 1/2"	<u>FM535R</u>
230 mm 9"	<u>FM536R</u>
250 mm 10"	<u>FM537R</u>

BM

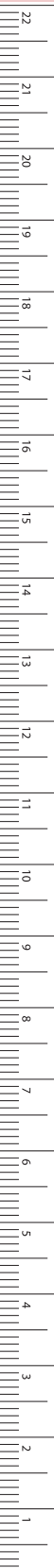

MILLIMETERS



Needle Holders - Portaaguja

DIA DUST® Micro Needle Holders with Flat Handles

DIA DUST® Portaaguja con mangos redondos para microcirugía

DIA DUST®



The diamond dust coating ensures an even harder and more wear resistant surface on the inside of the jaws. Moreover, the structure of the DIA DUST® coating guarantees a reliable grip for fine needles and sutures, as well as for tissue.

El recubrimiento de polvo de diamante asegura una superficie interior de la boca todavía más dura y más resistente al desgaste. La estructura del recubrimiento DIA DUST® además garantiza un agarre seguro de agujas finas y material de sutura así como tejido blando.



145 mm, 5 $\frac{3}{4}$ "

170 mm, 6 $\frac{3}{4}$ "

185 mm, 7 $\frac{1}{4}$ "

210 mm, 8 $\frac{1}{4}$ "

230 mm, 9"



DIA DUST®

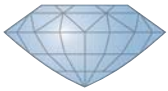

Needle Holders – Portaagujas

DIA DUST® Micro Needle Holders with Flat Handles

DIA DUST® Portaagujas con mangos redondos para microcirugía

BM



MILLIMETERS

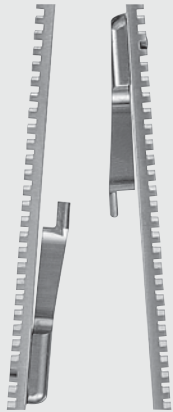

with catch
con cierre



Suture size
Medida del material de sutura

Length Longitud	7/0 and smaller 7/0 y más fino	5/0 and smaller 5/0 y más fino
145 mm 5 3/4"		FM541R
170 mm 6 3/4"	FM540R	
185 mm 7 1/4"		FM542R
210 mm 8 1/4"		FM543R
230 mm 9"		FM544R

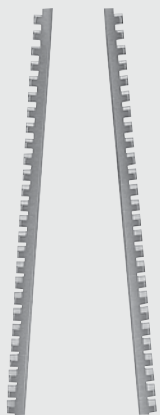

without catch
sin cierre



Suture size
Medida del material de sutura

Length Longitud	7/0 and smaller 7/0 y más fino	5/0 and smaller 5/0 y más fino
145 mm 5 3/4"		FM546R
170 mm 6 3/4"	FM545R	
185 mm 7 1/4"		FM547R
210 mm 8 1/4"		FM548R
230 mm 9"		FM549R

DIA DUST®



Needle Holders - Portaaguja

DIA DUST® Micro Needle Holders with Flat Handles

DIA DUST® Portaaguja con mangos redondos para microcirugía

DIA DUST®



The diamond dust coating ensures an even harder and more wear resistant surface on the inside of the jaws. Moreover, the structure of the DIA DUST® coating guarantees a reliable grip for fine needles and sutures, as well as for tissue.

El recubrimiento de polvo de diamante asegura una superficie interior de la boca todavía más dura y más resistente al desgaste. La estructura del recubrimiento DIA DUST® además garantiza un agarre seguro de agujas finas y material de sutura así como tejido blando.



185 mm, 7 1/4"

210 mm, 8 1/4"

230 mm, 9"

BM





DIA DUST®

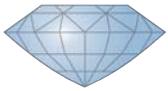

Needle Holders – Portaagujas

DIA DUST® Micro Needle Holders with Flat Handles

DIA DUST® Portaagujas con mangos redondos para microcirugía

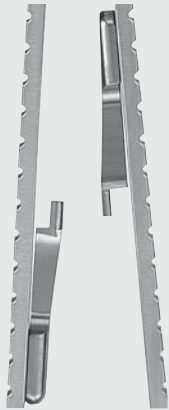

with catch
con cierre



Suture size
Medida del
material de sutura

Length
Longitud

5/0 and smaller
5/0 y más fino

185 mm
7 1/4"

FM550R

210 mm
8 1/4"

FM551R

230 mm
9"

FM552R



without catch
sin cierre



Suture size
Medida del
material de sutura

Length
Longitud

5/0 and smaller
5/0 y más fino

185 mm
7 1/4"

FM553R

210 mm
8 1/4"

FM554R

230 mm
9"

FM555R

BM



MILLIMETERS

Needle Holders - Portaaguja

DIA DUST® Micro Needle Holders

DIA DUST® Portaaguja para microcirugía

DIA DUST®



DIA DUST®

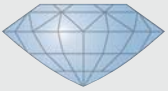

The diamond dust coating ensures an even harder and more wear resistant surface on the inside of the jaws. Moreover, the structure of the DIA DUST® coating guarantees a reliable grip for fine needles and sutures, as well as for tissue.

El recubrimiento de polvo de diamante asegura una superficie interior de la boca todavía más dura y más resistente al desgaste. La estructura del recubrimiento DIA DUST® además garantiza un agarre seguro de agujas finas y material de sutura así como tejido blando.



GLASSER

FM560R

Suture size: 5/0 and smaller

Medida del material de sutura:

5/0 y más fino

125 mm, 5"



GLASSER

FM561R

Suture size: 5/0 and smaller

Medida del material de sutura:

5/0 y más fino

180 mm, 7"

BM





Needle Holders – Portaagujas
 DIA DUST® Micro Needle Holders
 DIA DUST® Portaagujas para microcirugía

BM

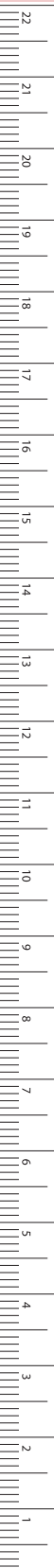

MILLIMETERS



FD258R-FD259R
 180 mm, 7"



FM236R
 with catch
 Suture size: 5/0 and smaller
 con cierre
 Medida del material de sutura: 5/0 y más fino
 210 mm, 8 1/4"



FM276R
 without catch
 Suture size: 5/0 and smaller
 sin cierre
 Medida del material de sutura: 5/0 y más fino
 210 mm, 8 1/4"



Needle Holders - Portaaguja

DIA DUST® Micro Needle Holders

DIA DUST® Portaaguja para microcirugía

DIA DUST®



The diamond dust coating ensures an even harder and more wear resistant surface on the inside of the jaws. Moreover, the structure of the DIA DUST® coating guarantees a reliable grip for fine needles and sutures, as well as for tissue.

El recubrimiento de polvo de diamante asegura una superficie interior de la boca todavía más dura y más resistente al desgaste. La estructura del recubrimiento DIA DUST® además garantiza un agarre seguro de agujas finas y material de sutura así como tejido blando.



- The broad back of the jaw exerts greater force on the needle, facilitating a secure hold.
- El ancho dorso de la boca ejerce mayor fuerza sobre la aguja, facilitando un agarre seguro.



BM300R

195 mm, 7 3/4"

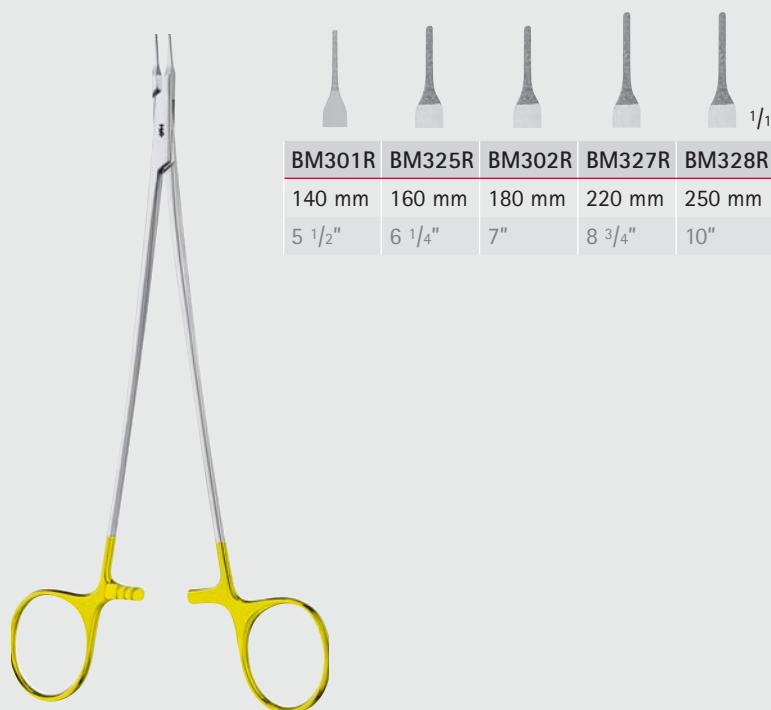

BM301R	BM325R	BM302R	BM327R	BM328R
140 mm	160 mm	180 mm	220 mm	250 mm
5 1/2"	6 1/4"	7"	8 3/4"	10"

RYDER

BM301R-BM328R

Suture Size: 5/0 and smaller

Medida de material de sutura: 5/0 y más fino





Needle Holders – Portaaguja
Needle Holders
Portaaguja

BM

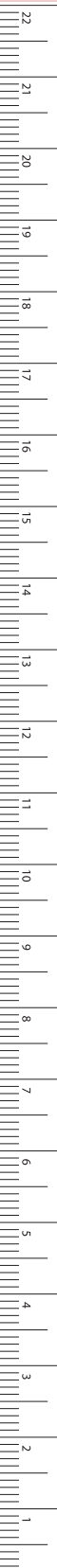

CONVERSE

BM200R

130 mm, 5 1/8"

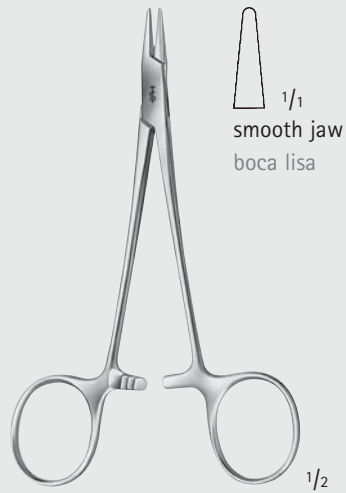

WEBSTER

BM202R

125 mm, 5"



HALSEY

BM201R-BM205R

130 mm, 5 1/8"



DERF

BM204R

125 mm, 5"



DOYEN

BM210R

125 mm, 5"



BAUMGARTNER

BM215R

145 mm, 5 3/4"

MILLIMETERS

Needle Holders - Portaagujas

Needle Holders

Portaagujas

BM



$\frac{1}{1}$
delicate platter
modelo fino

CRILE-WOOD

BM218R

150 mm, 6"

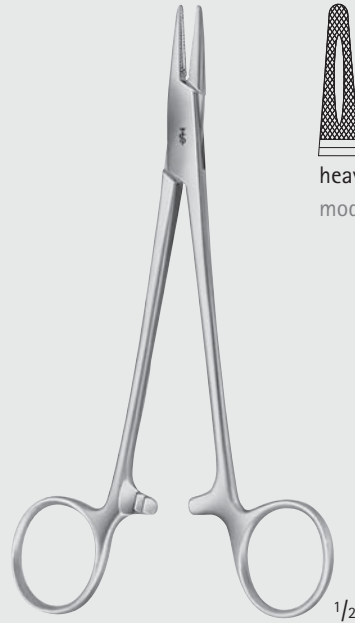

$\frac{1}{1}$
heavy platter
modelo fuerte

CRILE-WOOD

BM220R

160 mm, 6 1/4"



$\frac{1}{1}$

CRILE-MURRAY

BM219R

150 mm, 6"



$\frac{1}{1}$

KILNER

BM211R

135 mm, 6"

INCHES



Needle Holders – Portaaguja

Needle Holders

Portaaguja

BM

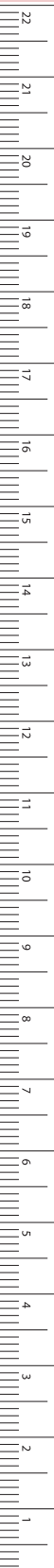

LAWRENCE

BM221R

150 mm, 6"



ADSON

BM224R

180 mm, 7"

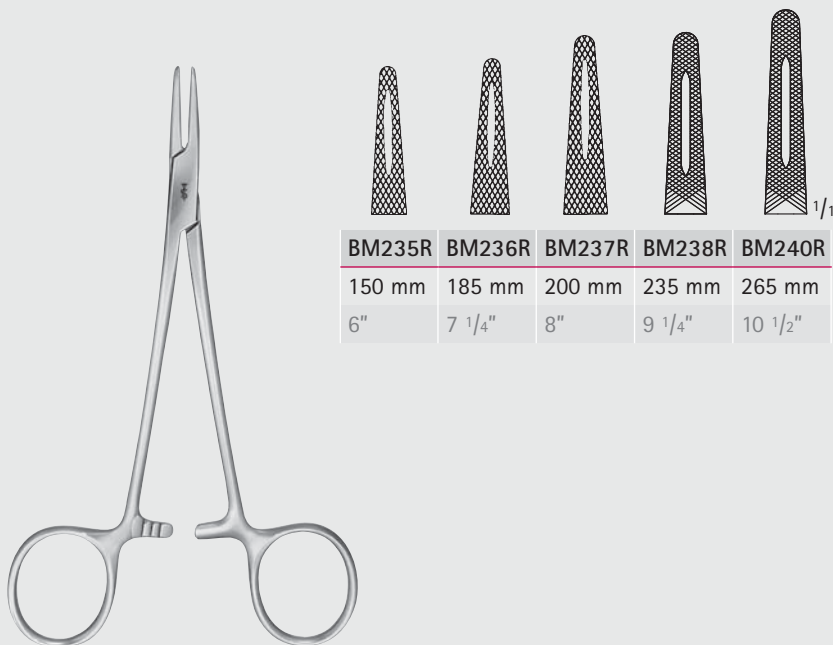

MAYO-HEGAR

BM235R-BM240R

Medium fine patterns

Modelos medio finos

Needle Holders - Portaaguja

Needle Holders

Portaaguja

BM

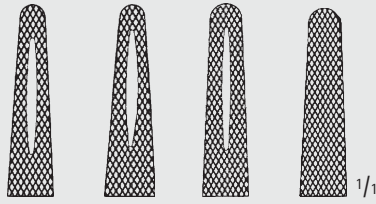

BM245R	BM247R	BM249R	BM255R
150 mm	175 mm	205 mm	205 mm
6"	7"	8"	8"

HEGAR

BM245R-BM255R

Heavy patterns

Modelos fuertes

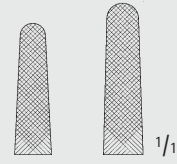

BM241R	BM242R
165 mm	190 mm
6 1/2"	7 1/2"

MAYO-HEGAR

BM241R-BM242R

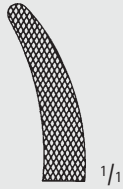

HEANEY

BM259R

200 mm, 8"



JAMESON

BM270R

230 mm, 9"



Needle Holders – Portaaguja
Needle Holders
Portaaguja

BM

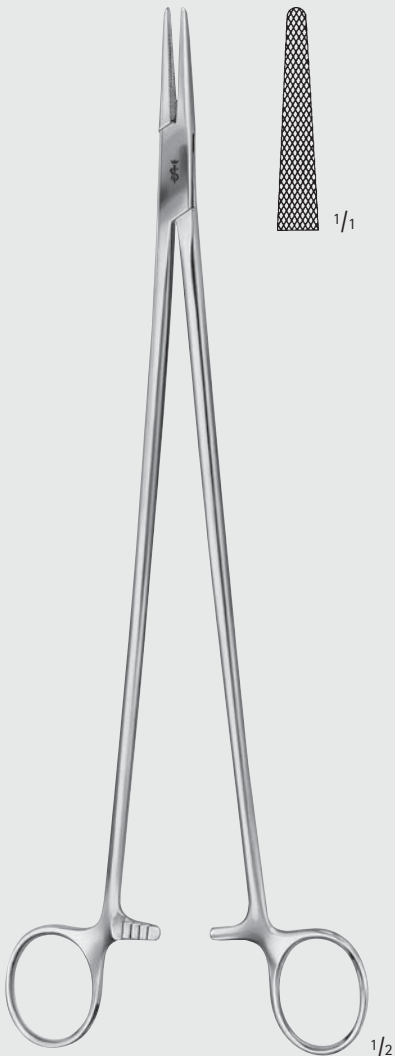

WANGENSTEEN

BM272R

275 mm, 10 3/4"



MASSON

BM275R

265 mm, 10 1/2"

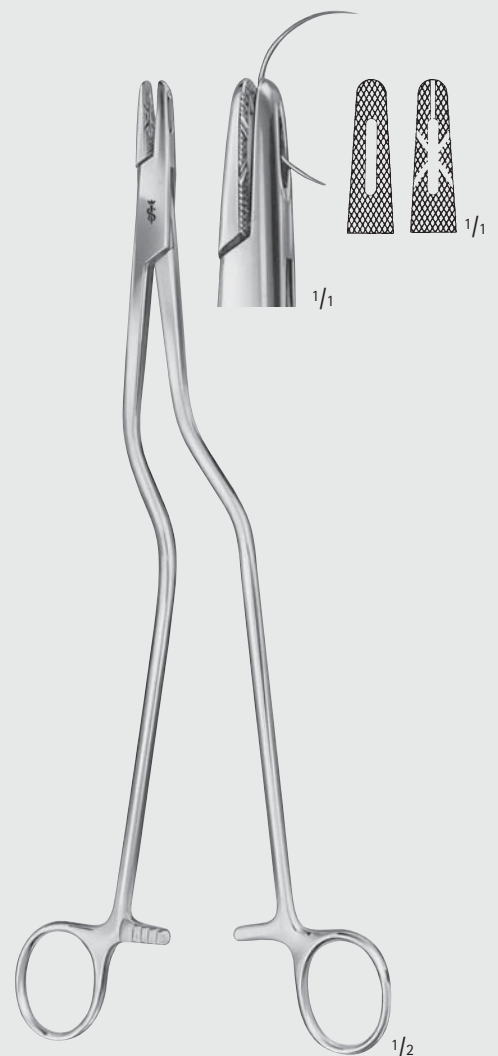

MASSON-LUETHY

BM280R

255 mm, 10"

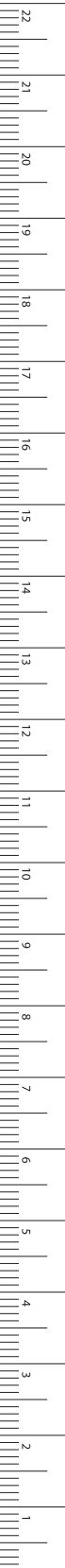

Needle Holders - Portaaguja

Needle Holders with Scissors

Portaaguja con tijera

BM

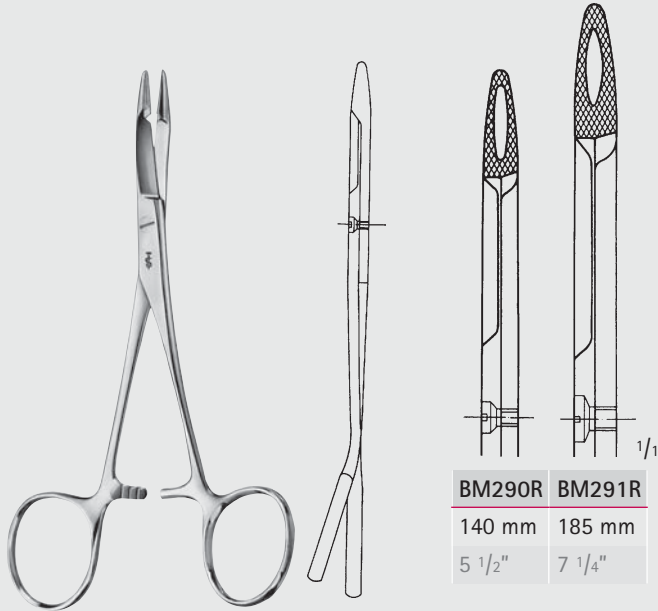

BM290R	BM291R
140 mm	185 mm
5 1/2"	7 1/4"

HEGAR-OLSEN

BM290R-BM291R

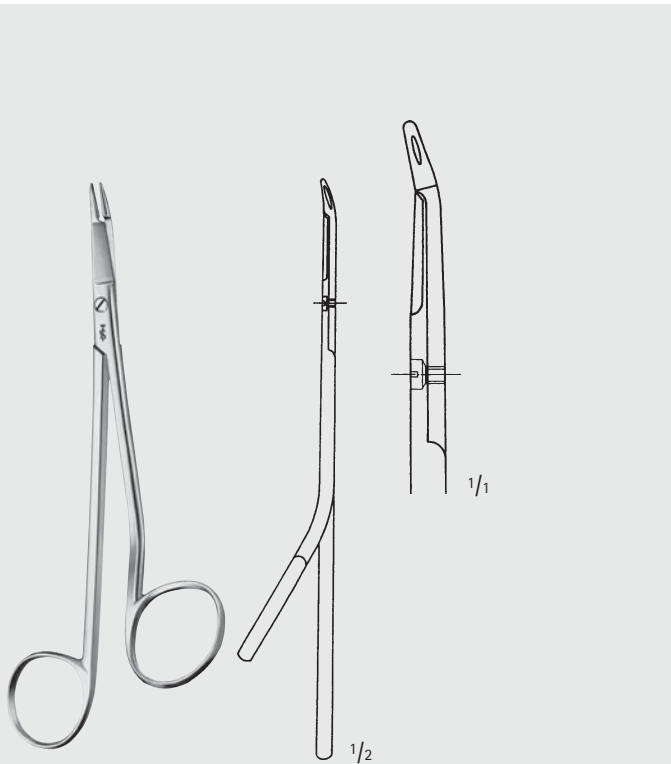

GILLIES

BM298R

150 mm, 6"



GILLIES

BM299R

160 mm, 6 1/4"

INCHES



Needle Holders – Portaaguja
Needle Holders
Portaaguja

BM



CRILE

BM503R

150 mm, 6"



TÖNNIS

BM510R

Elastic pattern for dura- or intestinal suture

Modelo elástico para sutura de la duramadre o del intestino

180 mm, 7"

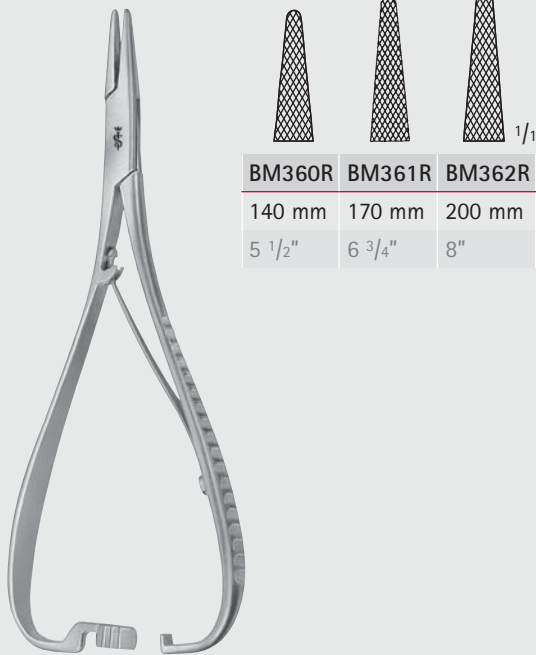

MATHIEU

BM360R-BM362R

BM360R	BM361R	BM362R
140 mm	170 mm	200 mm
5 1/2"	6 3/4"	8"

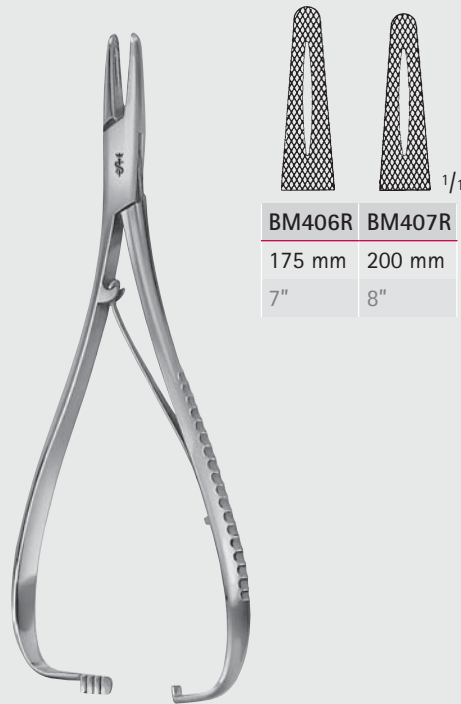

MATHIEU-STILLE

BM406R-BM407R

Very heavy patterns

Modelos muy fuertes



MILLIMETERS

Needle Holders - Portaaguja

DUROGRIP® Needle Holders

Portaaguja DUROGRIP®

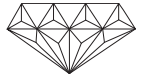

BM

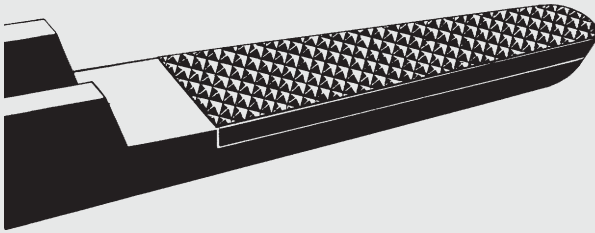

smooth
liso



0.2



0.4



0.5

Aesculap needle holders have jaws with carbide inserts and according to the use required the resp. structure can be chosen. A smooth jaw surface as well as 3 different serrations guarantee a sure „grip“ of the resp. needle.

Portaaguja Aesculap son adaptados a cada material de sutura conforme con la indicación por medio de la estructura de las distintas bocas de metal extraduro. La boca lisa y 3 distintos perfiles garantizan un agarre seguro de cada aguja.

We recommend carbide inserts with smooth jaw surface for suture material with 0.2 mm pitch of serration for suture material 0.4 mm 0.5 mm

9/0 – 11/0
6/0 – 10/0
4/0 – 6/0
up to 3/0

Recomendamos bocas de metal extraduro con superficie lisa para material de sutura con estructura 0,2 mm para material de sutura 0,4 mm 0,5 mm

9/0 – 11/0
6/0 – 10/0
4/0 – 6/0
hasta 3/0



DUROGRIP® Needle holders with carbide inserts

Identification:

■ gold-plated rings, handle ends and ratchets

Portaaguja DUROGRIP® con placas de metal extraduro

Identificación:

■ Anillos, ramas y cremalleras dorados





Needle Holders – Portaaguja
DUROGRIP® Needle Holders
 Portaaguja DUROGRIP®

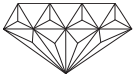

BM

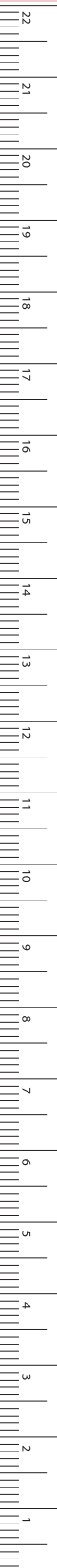

MILLIMETERS

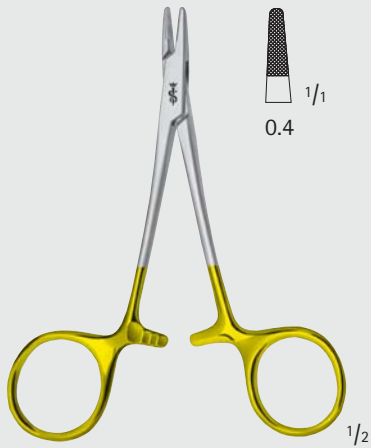

DERF

BM008R

115 mm, 4 1/2"



HALSEY

BM010R

120 mm, 4 3/4"

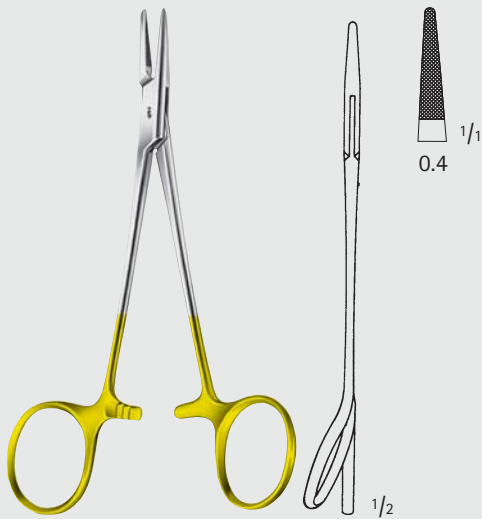

MASING

BM009R

one ring angled
 un anillo con ángulo
 130 mm, 5 1/8"



CONVERSE

BM011R

130 mm, 5 1/8"

Needle Holders - Portaaguja

DUROGRIP® Needle Holders

Portaaguja DUROGRIP®

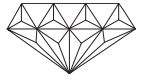

BM



HALSEY

BM012R

130 mm, 5 1/8"



WEBSTER

BM014R-BM024R

125 mm, 5"



KILNER

BM018R

135 mm, 5 1/4"



BAUMGARTNER

BM015R

145 mm, 5 3/4"





Needle Holders – Portaagujas
DUROGRIP® Needle Holders
 Portaagujas DUROGRIP®

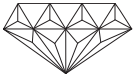

BM

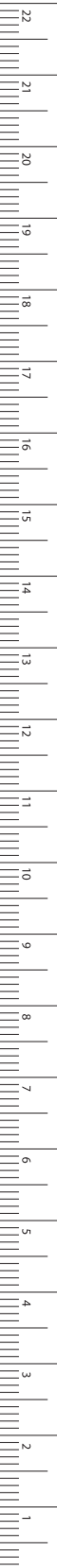

BABY-CRILE-WOOD

BM013R

150 mm, 6"



CRILE-WOOD

BM016R-BM030R

BM016R	BM017R	BM019R	BM030R	BM021R
145 mm	185 mm	200 mm	270 mm	305 mm
5 3/4"	7 1/4"	8"	10 3/8"	12"



SAROT

BM020R-BM023R

BM020R	BM023R
175 mm	260 mm
7"	10 1/4"



HEGAR-MAYO-SEELEY

BM022R

200 mm, 8"

Needle Holders - Portaaguja

DUROGRIP® Needle Holders

Portaaguja DUROGRIP®

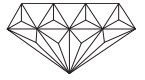

BM

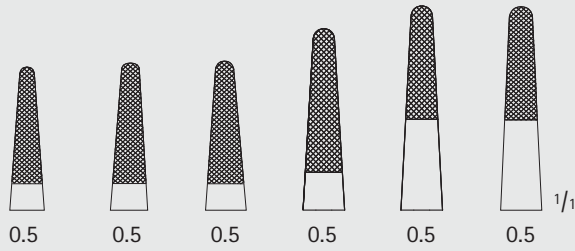

BM065R	BM066R	BM067R	BM068R	BM070R	BM069R
150 mm	185 mm	205 mm	235 mm	265 mm	300 mm
6"	7 1/4"	8"	9 1/4"	10 1/2"	12"

HEGAR-MAYO

BM065R-BM070R

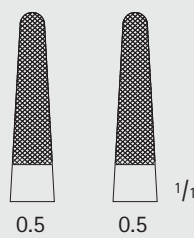

BM077R	BM078R
205 mm	245 mm
8"	9 3/4"

HEGAR

BM077R-BM078R

Heavy patterns
Modelos fuertes



Needle Holders - Portaagujas
DUROGRIP® Needle Holders with Scissors
 Portaagujas con tijera DUROGRIP®

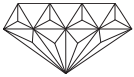

BM

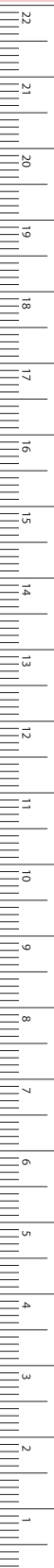

BM127R
 125 mm, 5"



HEGAR-OLSEN MODIF. LANGE
BM128R
 145 mm, 5 3/4"

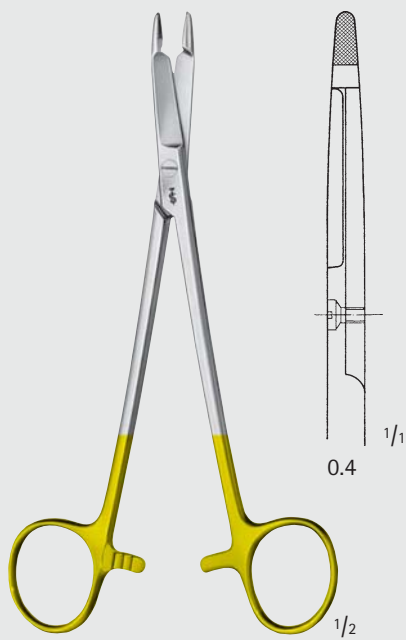

HEGAR-OLSEN
BM124R
 1 blade fine serrated
 un filo dentado
 165 mm, 6 1/2"

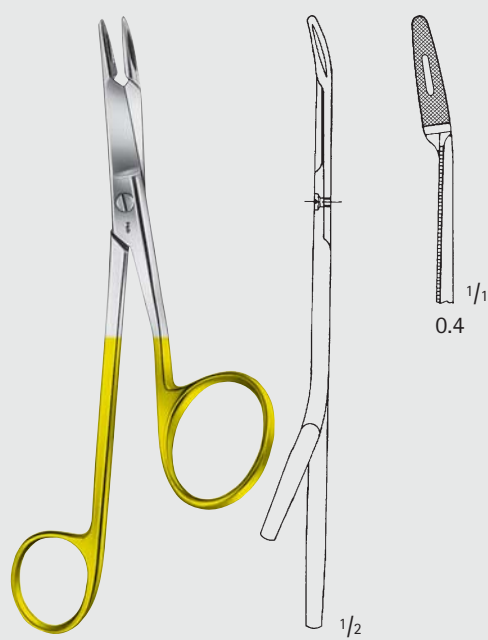

GILLIES
BM129R
 160 mm, 6 1/4"

Needle Holders - Portaaguja

DUROGRIP® Needle Holders, Wire Twisters, Ligature Forceps

DUROGRIP® Portaaguja, pinzas para tensar alambres, pinzas para ligadura

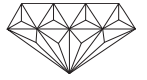

BM

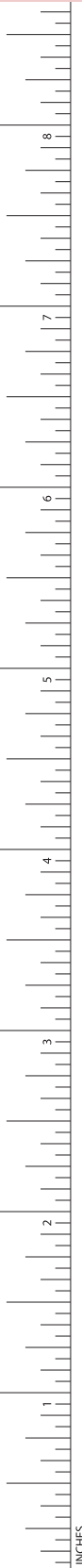

BM110R

150 mm, 6"



BM111R

150 mm, 6"



BAUMGARTNER

BM112R

200 mm, 8"



BM113R

175 mm, 7"

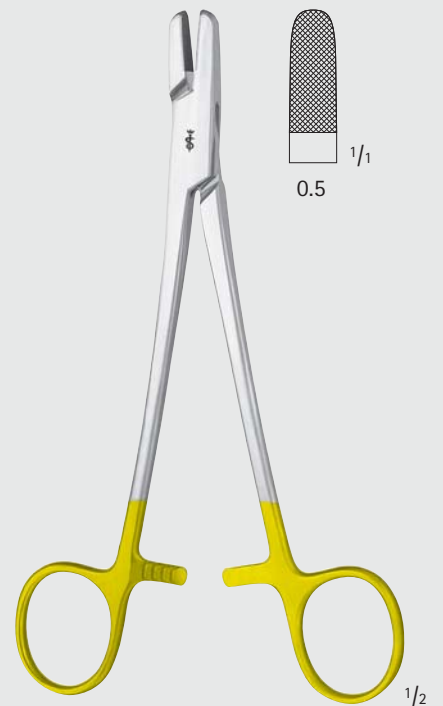

BERRY

MD456R

185 mm, 7 1/4"



Needle Holders – Portaaguja
DUROGRIP® Needle Holders
 Portaaguja DUROGRIP®

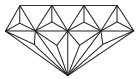

»grazil«

BM

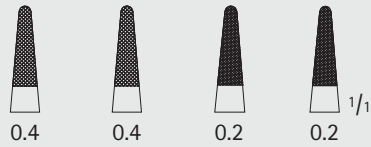

BM033R	BM034R	BM063R	BM064R
165 mm	210 mm	165 mm	210 mm
6 1/2"	8 1/4"	6 1/2"	8 1/4"

DE BAKAY

BM033R-BM064R

very delicate
 muy fina

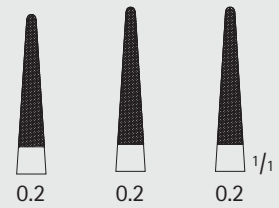

BM025R	BM026R	BM027R
180 mm	200 mm	230 mm
7"	8"	9"

BM025R-BM027R

very delicate
 muy fina

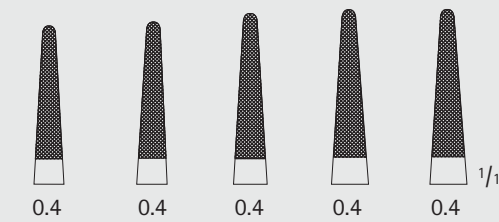

BM032R	BM035R	BM036R	BM037R	BM038R
150 mm	180 mm	230 mm	250 mm	305 mm
6"	7"	9"	10"	12"

DE BAKAY

BM032R-BM038R

1/2



MILLIMETERS

Needle Holders - Portaagujas

DUROGRIP® Needle Holders

Portaagujas DUROGRIP®

»grazil«

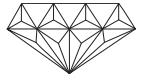

BM



DE BAKEY

BM040R

Slender pattern
Modelo delgado
305 mm, 12"

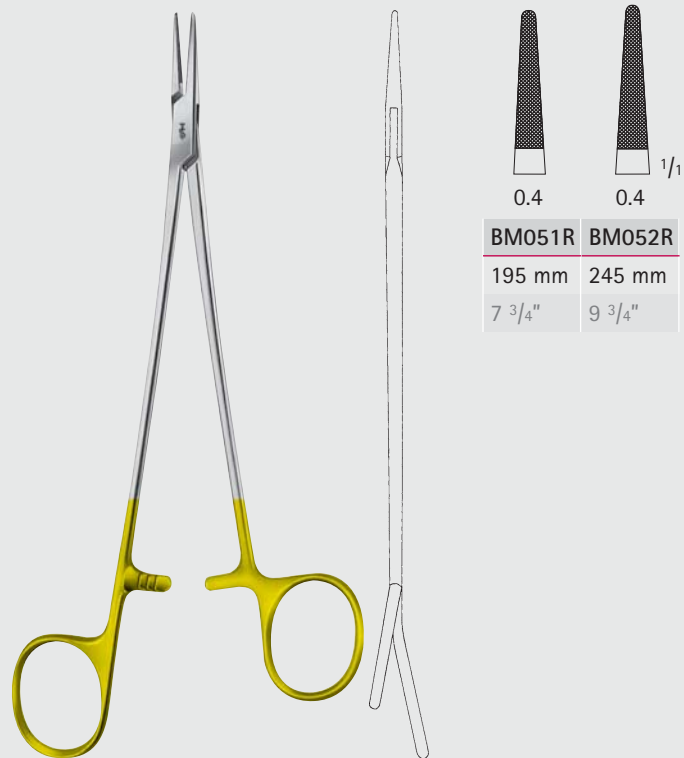

DE BAKEY

BM051R-BM052R

one extended handle and curved
rings ensure optimum grip
con anillos a diferente altura, acodados,
para mejor sujeción

BM051R	BM052R
195 mm	245 mm
7 3/4"	9 3/4"



Needle Holders - Portaaguja
DUROGRIP® Needle Holders
 Portaaguja DUROGRIP®

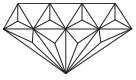

BM

0.5	0.5	0.5
BM100R	BM101R	BM102R
200 mm	240 mm	300 mm
8"	9 1/2"	12"

WERTHEIM
BM100R-BM102R

0.5	0.5
BM095R	BM096R
210 mm	230 mm
8 1/4"	9"

STRATTE
BM095R-BM096R

0.5	0.5
BM081R	BM084R
200 mm	260 mm
8"	10 1/4"

HEANEY
BM081R-BM084R

BM082R
 S-shaped
 curvado en forma de S
 215 mm, 8 1/2"



MILLIMETERS

Needle Holders - Portaaguja

DUROGRIP® Needle Holders

Portaaguja DUROGRIP®

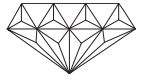

BM



WANGENSTEEN

BM042R

275 mm, 10 3/4"



BM105R

275 mm, 10 3/4"



Needle Holders – Portaaguja
DUROGRIP® Needle Holders
Portaaguja DUROGRIP®

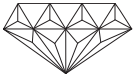

BM



NAUNTON-MORGAN

BM088R

260 mm, 10 1/2"



MÜLLER

BM089R

for deep rectum surgery
para cirugía rectal profunda
360 mm, 14"

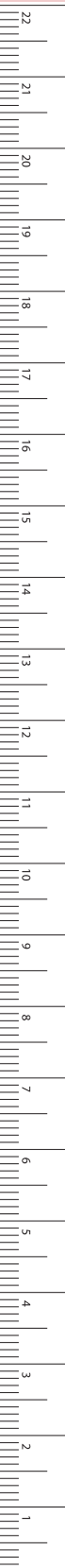

MILLIMETERS

Needle Holders - Portaaguja

DUROGRIP® Needle Holders

Portaaguja DUROGRIP®

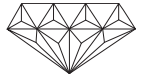

BM



MASSON

BM090R

265 mm, 10 1/2"



FINOCHIETTO

BM092R

265 mm, 10 1/2"



Needle Holders - Portaaguja DUROGRIP® Needle Holders Portaaguja DUROGRIP®

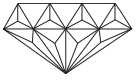

These special patterns with extremely fine jaws are suitable for holding non-traumatic needles and fine vein needles.

Estos modelos especiales con bocas sumamente finas son apropiados para agujas atraumáticas y para agujas vasculares finas.

BM

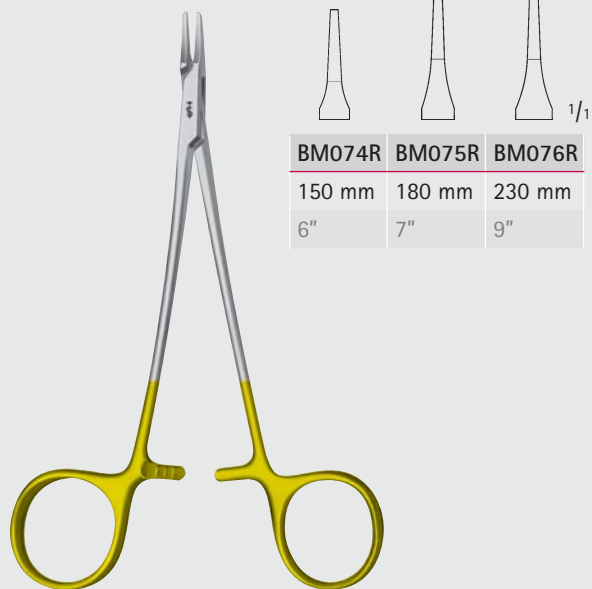

RYDER

BM074R-BM076R

With smooth jaws

Con boca lisa



BM184R

200 mm, 8"

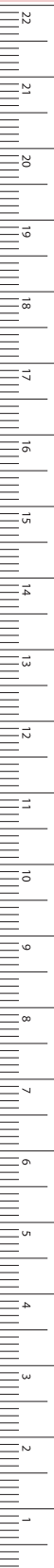

MILLIMETERS

Needle Holders - Portaaguja

DUROGRIP® Needle Holders

Portaaguja DUROGRIP®

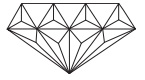

These special patterns with extremely fine jaws are suitable for holding non-traumatic needles and fine vein needles.

Estos modelos especiales con bocas sumamente finas son apropiados para agujas atraumáticas y para agujas vasculares finas.

»grazil«

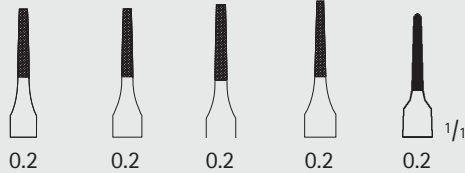

BM054R	BM055R	BM056R	BM057R	BM058R
135 mm	155 mm	175 mm	210 mm	230 mm
5 1/4"	6"	7"	8 1/4"	9"

RYDER

BM054R-BM058R

very delicate

muy fina

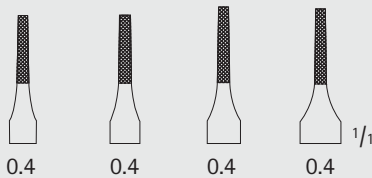

BM044R	BM045R	BM046R	BM047R
135 mm	175 mm	195 mm	265 mm
5 1/4"	7"	7 3/4"	10 1/2"

RYDER

BM044R-BM047R

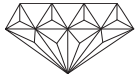

Needle Holders - Portaagujas

DUROGRIP® Needle Holders, Ergonomic Handle

Portaagujas DUROGRIP®, mango ergonómico

These instruments provide the surgeon with a maximum of ergonomical comfort. The optimized design of the Instruments offers a fatiguefree working especially with regard to difficult suture and anastomosis techniques.

Estos instrumentos ofrecen al cirujano máximo confort ergonómico. El diseño optimizado de los instrumentos permite al cirujano trabajar sin fatiga, especialmente cuando emplea técnicas de sutura y anastomosis difíciles.

BM



MILLIMETERS



HELLBERG-KUPKA

BM320R

with locking ratchet
con mecanismo de cierre
210 mm, 8 1/4"



REIN-KUPKA

BM310R

without ratchet
sin cierre
190 mm, 7 1/2"



REIN-KUPKA

BM311R

with ratchet
con cierre
190 mm, 7 1/2"

Needle Holders - Portaaguja

DUROGRIP® Needle Holders

Portaaguja DUROGRIP®

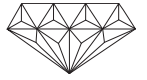

BM



TÖNNIS

BM186R

Elastic pattern

Modelo elástico

180 mm, 7"



TÖNNIS MODIF.

BM183R

Elastic pattern

Modelo elástico

180 mm, 7"



LANGENBECK

BM191R-BM193R

BM191R	BM193R
180 mm	200 mm
7"	8"



LANGENBECK

BM196R

200 mm, 8"

»grazil«



Needle Holders - Portaaguja
DUROGRIP® Needle Holders
 Portaaguja DUROGRIP®

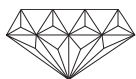

BM



MILLIMETERS



ZWEIFEL

BM170R

200 mm, 8"



ZWEIFEL

BM172R

200 mm, 8"



AESCULAP

BM178R

200 mm, 8"

Needle Holders - Portaaguja

DUROGRIP® Needle Holders

Portaaguja DUROGRIP®

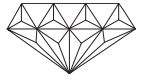

BM

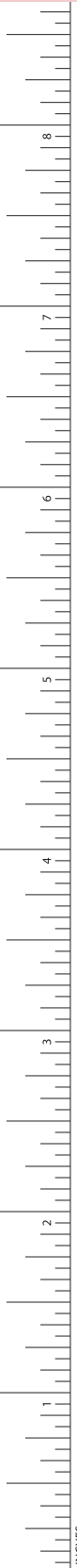

»grazil«



LICHTENBERG

BM132R

elastic pattern
modelo elástico

195 mm, 7 3/4"



HÖSEL

BM165R

with long neck
con articulación larga

205 mm, 8"



HÖSEL

BM168R

with long neck
con articulación larga

260 mm, 10"



Needle Holders – Portaagujas
DUROGRIP® Needle Holders
 Portaagujas DUROGRIP®

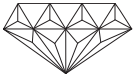

»grazil«

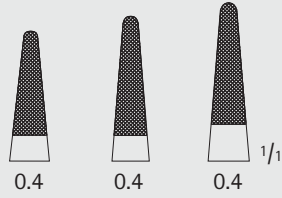

BM148R	BM150R	BM153R
140 mm	170 mm	200 mm
5 1/2"	6 3/4"	8"

MATHIEU

BM148R-BM153R

Delicate patterns

Modelos finos

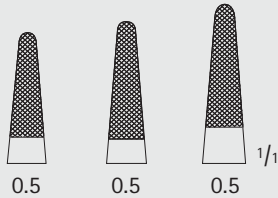

BM149R	BM151R	BM154R
140 mm	170 mm	200 mm
5 1/2"	6 3/4"	8"

MATHIEU

BM149R-BM154R

Standard patterns

Modelos estándar

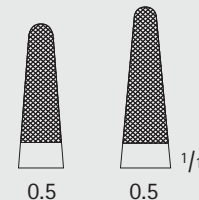

BM156R	BM158R
200 mm	245 mm
8"	9 3/4"

MATHIEU

BM156R-BM158R

Heavy patterns

Modelos fuertes

BM



Needle Holders - Portaaguja

Boomerang Needle Holders

Portaaguja Bumerang

BM



BM627R



BM628R



BM629R

BM627R-BM629R

Spare needles

Aguja de repuesto



1/2

YOUNG-HRYNTSCHAK

BM620R

Boomerang Needle Holder
with 1 needle BM627R
Portaaguja Bumerang con
1 aguja BM627R
240 mm, 9 1/2"



1/2

MILLIN

EF168R

Ligature holding forceps
Pinza portaligaduras
285 mm, 9 3/4"



Needle Holders - Portaaguja
Suture Instruments - Reverdin Needles
Instrumentos para sutura - Agujas de Reverdin

BM

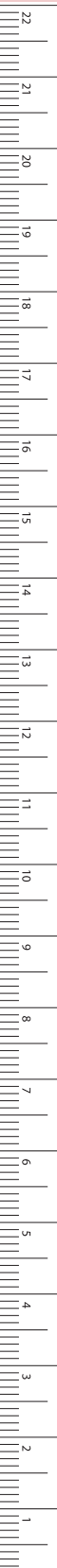

MILLIMETERS



REVERDIN

BM711R-BM714R
195 mm, 7 3/4"



BM711R

BM712R

BM713R

BM714R

Needle Holders - Portaaguja
Suture Instruments - Reverdin Needles
Instrumentos para sutura - Agujas de Reverdin

BM

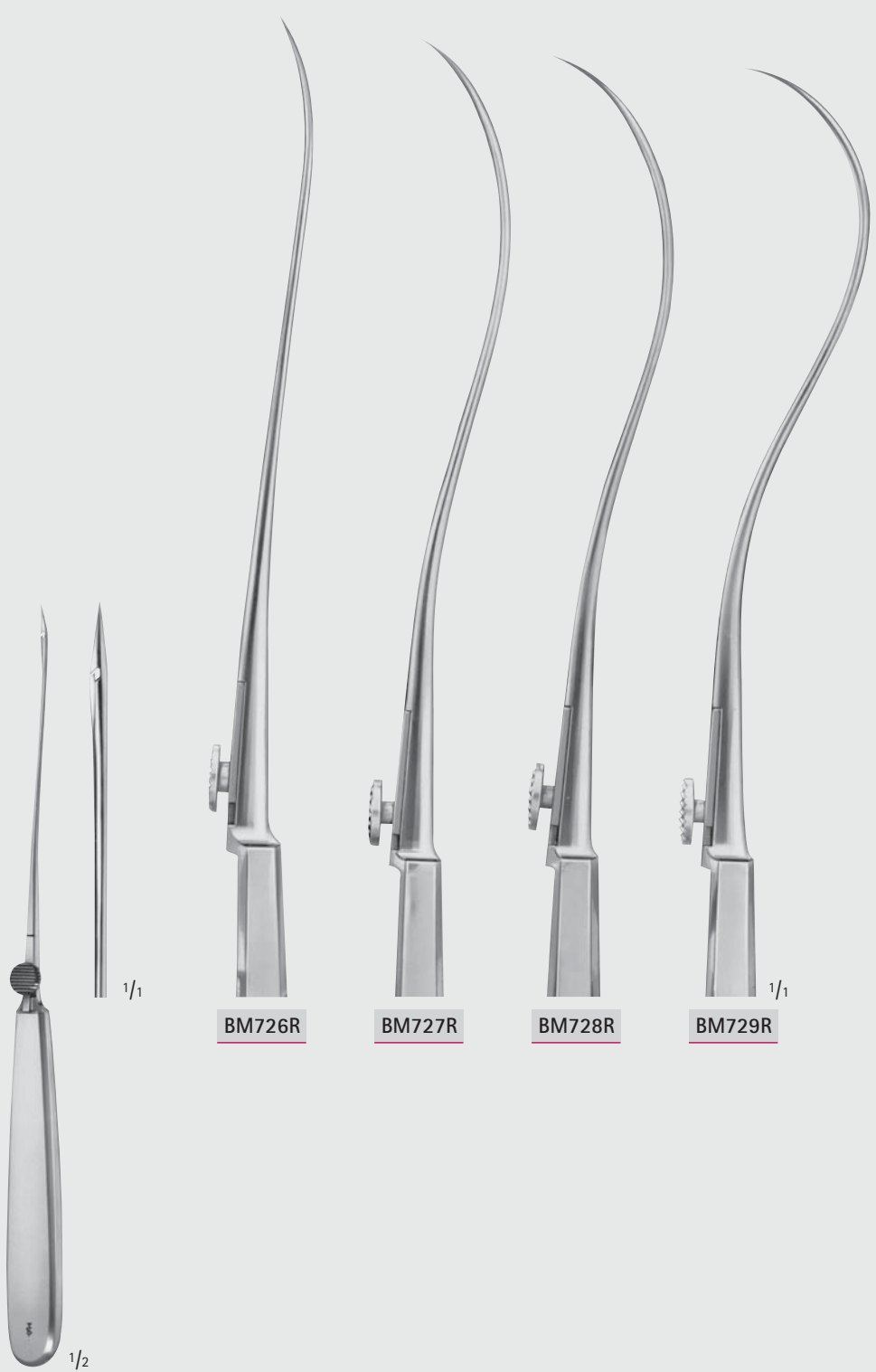

BM726R

BM727R

BM728R

BM729R

1/1

1/2

REVERDIN

BM726R-BM729R

220 mm, 8 3/4"



Needle Holders - Portaagujas
Suture Instruments - Ligature Needles
Instrumentos para sutura - Aguja para ligadura

BM

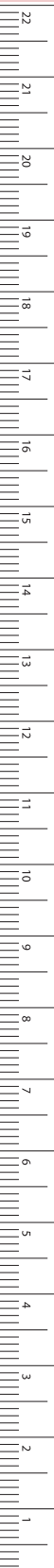

MILLIMETERS

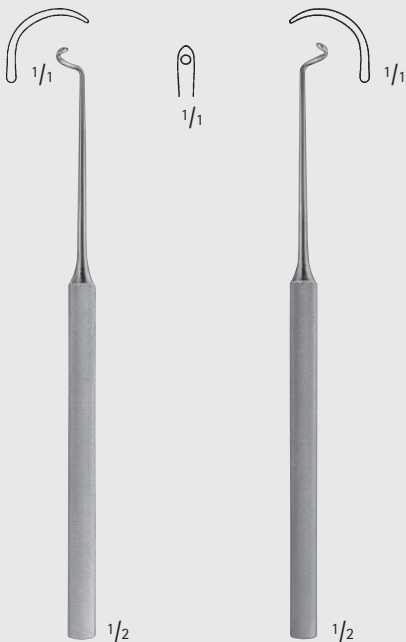

KRONECKER

BM801R

for right hand
blunt
para la mano
derecha, roma
155 mm, 6"

KRONECKER

BM802R

for left hand
blunt
para la mano izquierda,
roma
155 mm, 6"



DESCHAMPS

BM812R

for right hand
steep turn
blunt
para la mano
derecha, curvatura
escarpada, roma
225 mm, 9"

DESCHAMPS

BM813R

for left hand
steep turn
blunt
para la mano
izquierda, curvatura
escarpada, roma
225 mm, 9"



DESCHAMPS

BM814R

for right hand
steep turn
blunt
para la mano
derecha, curvatura
escarpada, roma
225 mm, 9"

Needle Holders - Portaaguja
 Suture Instruments - Ligature Needles
 Instrumentos para sutura - Aguja para ligadura

BM

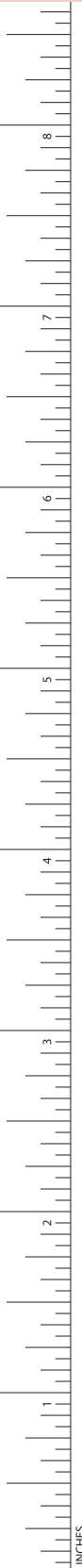

DESCHAMPS
BM806R
 for right hand
 blunt
 para la mano
 derecha, roma
 215 mm, 8 1/2"



DESCHAMPS
BM807R
 for left hand
 blunt
 para la mano
 izquierda, roma
 215 mm, 8 1/2"



DESCHAMPS
BM808R
 for right hand
 blunt
 para la mano
 derecha, roma
 210 mm, 8 1/4"



DESCHAMPS
BM809R
 for left hand
 blunt
 para la mano
 izquierda, roma
 210 mm, 8 1/4"



Needle Holders - Portaaguja
 Suture Instruments - Ligature Needles
 Instrumentos para sutura - Aguja para ligadura

BM



MILLIMETERS

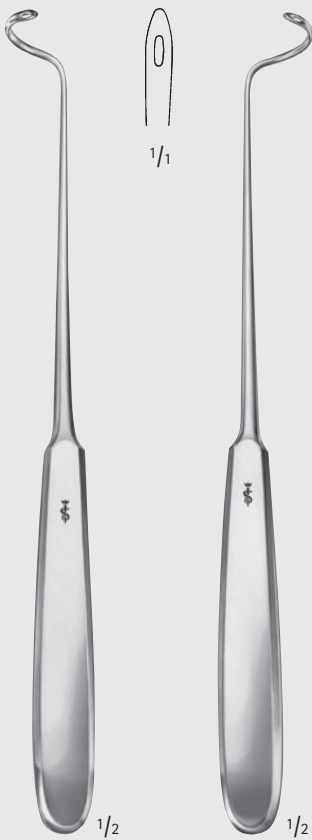
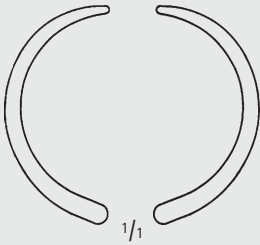

DESCHAMPS
BM810R
 for right hand
 blunt
 para la mano
 derecha, roma
 215 mm, 8 1/2"

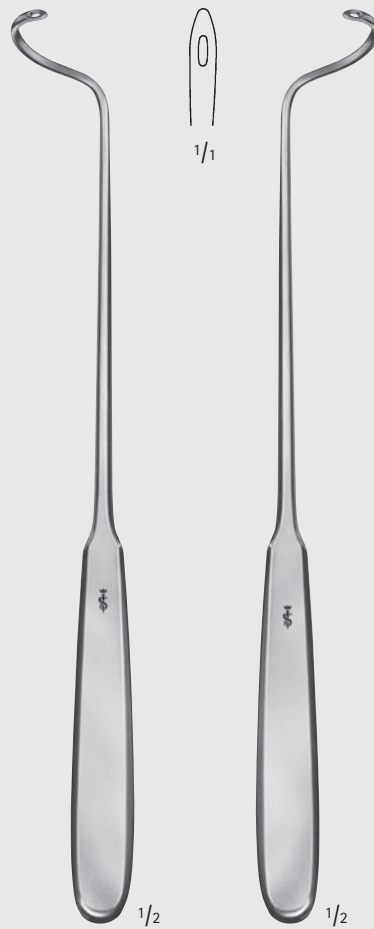
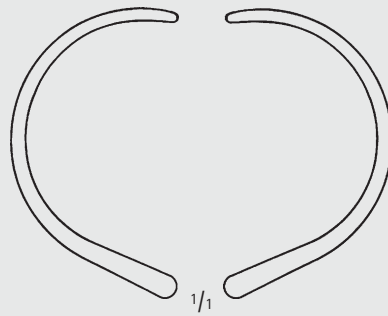

DESCHAMPS
BM822R
 for right hand
 blunt
 para la mano
 derecha, roma
 240 mm, 9 1/2"



DESCHAMPS
BM823R
 for left hand
 blunt
 para la mano
 izquierda, roma
 240 mm, 9 1/2"

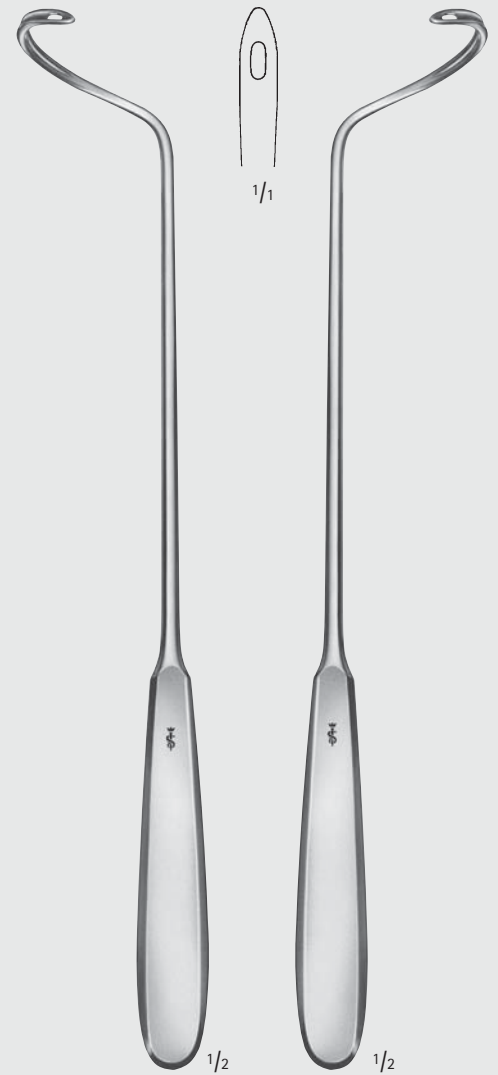
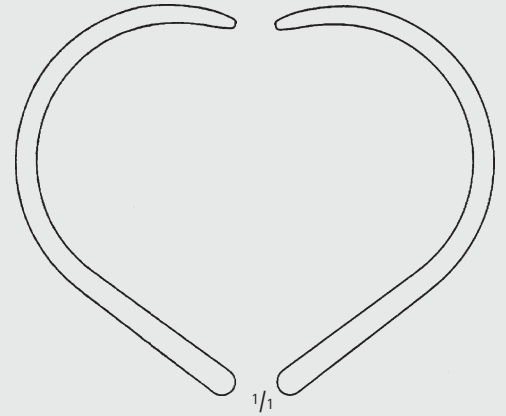

DESCHAMPS
BM824R
 for right hand
 blunt
 para la mano
 derecha, roma
 280 mm, 11"



DESCHAMPS
BM825R
 for left hand
 blunt
 para la mano
 izquierda, roma
 280 mm, 11"

Needle Holders - Portaaguja
 Suture Instruments - Ligature Needles
 Instrumentos para sutura - Aguja para ligadura

BM

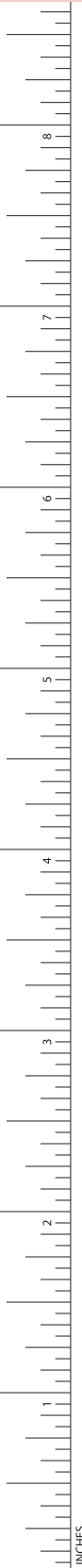

HURD
BM770R
 for right hand sharp
 para la mano derecha, aguda
 210 mm, 8 1/4"



HURD
BM771R
 for left hand sharp
 para la mano izquierda, aguda
 210 mm, 8 1/4"



DESCHAMPS
BM780R
 for right hand sharp
 para la mano derecha, aguda
 210 mm, 8 1/4"



DESCHAMPS
BM781R
 for left hand sharp
 para la mano izquierda, aguda
 210 mm, 8 1/4"



Needle Holders - Portaaguja
 Suture Instruments - Ligature Needles
 Instrumentos para sutura - Aguja para ligadura

BM

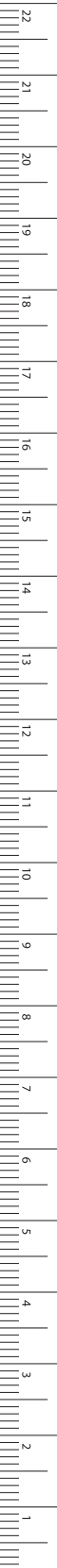

MILLIMETERS

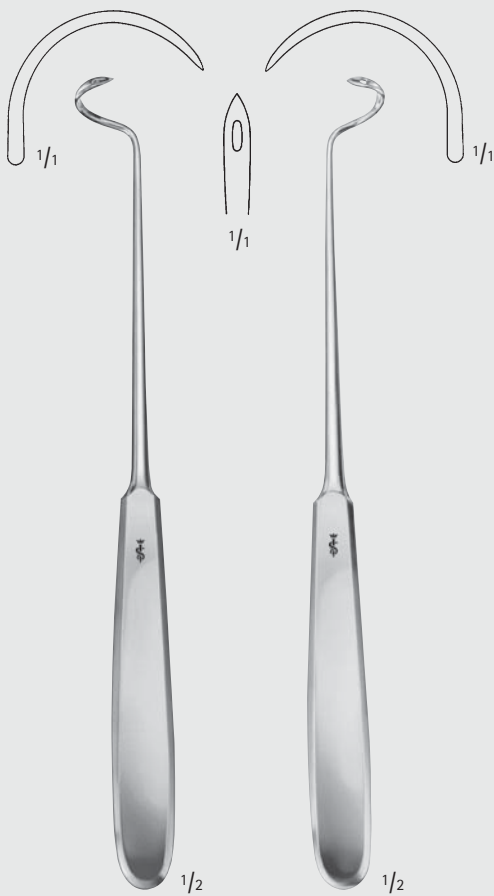

DESCHAMPS

BM748R

for right hand
 sharp
 para la mano
 derecha, aguda
 215 mm, 8 1/2"

DESCHAMPS

BM749R

for left hand
 sharp
 para la mano
 izquierda, aguda
 215 mm, 8 1/2"



JONESCO

BM755R

Needle for wire suture
 Aguja para sutura con alambre
 185 mm, 7 1/4"

Needle Holders - Portaaguja

Ligature Needles

Agujas para ligadura

BM

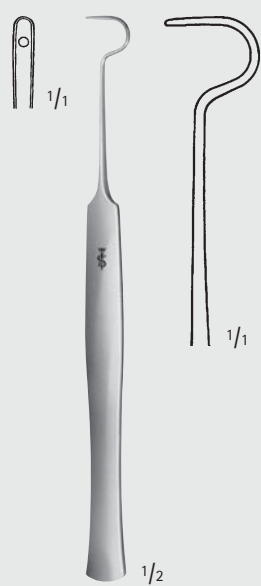

BM853R

150 mm, 6"

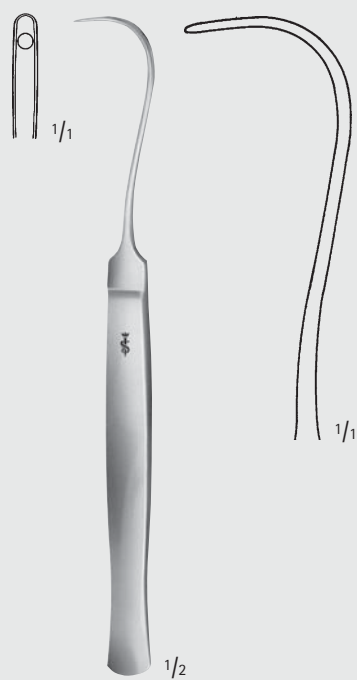

SYME

BM855R

170 mm, 6 3/4"

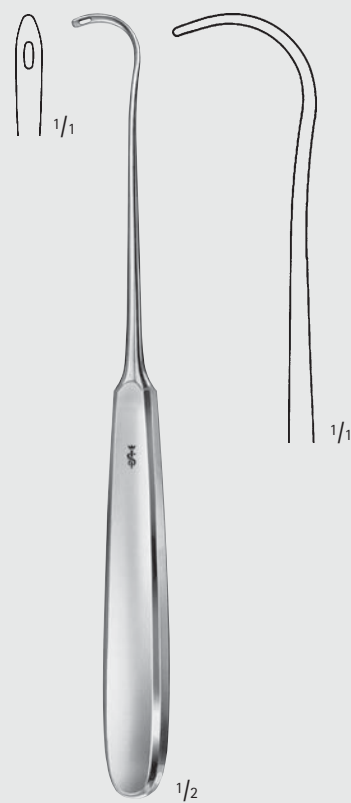

COOPER

BM856R

205 mm, 8"



Needle Holders – Portaaguja
Ligature Needles
Agujas para ligadura

BM

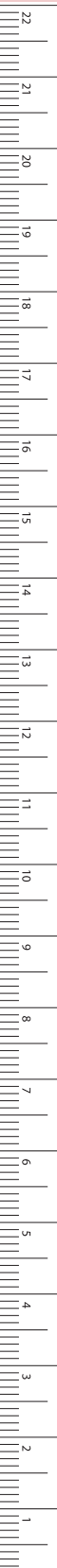

MILLIMETERS

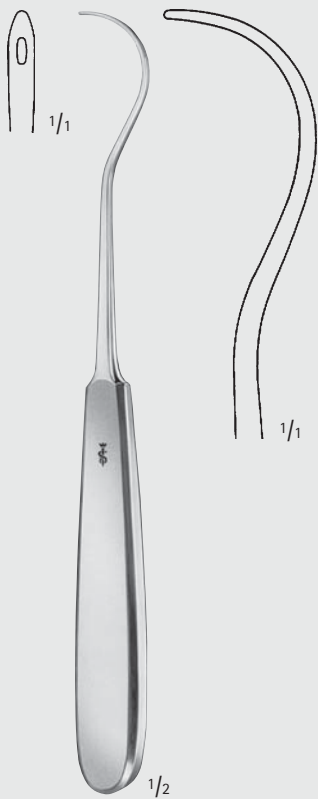

KOCHER

BM858R

205 mm, 8"

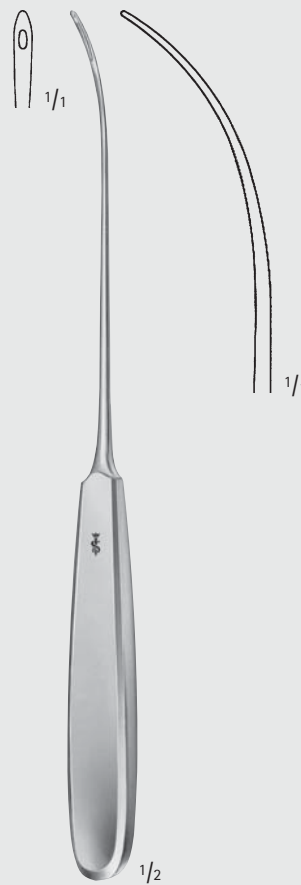

BM861R

malleable

maleable

230 mm, 9"

Needle Holders - Portaaguja

BRUNNER Ligature Needles, Guiding Probes

Agujas para ligadura, sondas conductoras acanaladas BRUNNER

BM

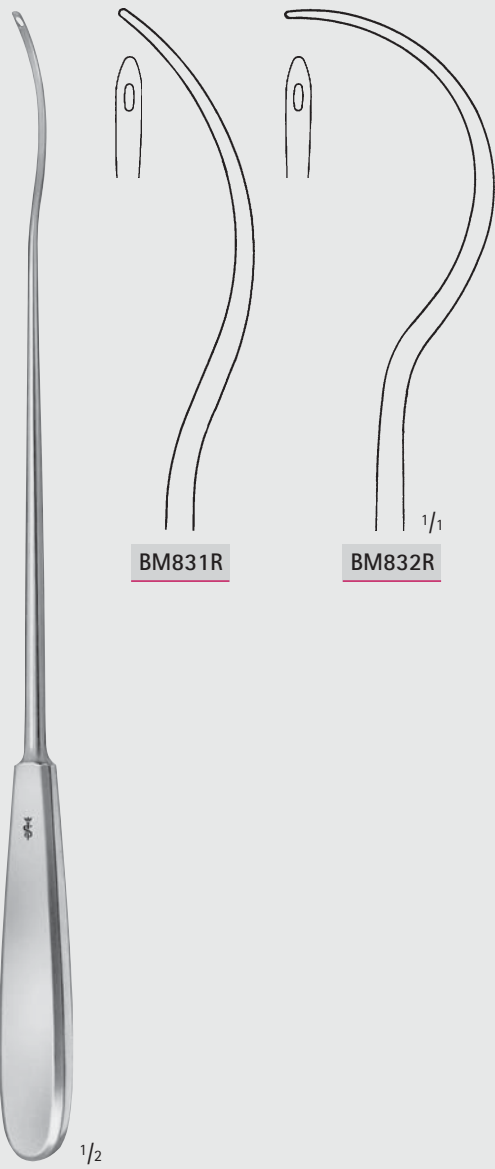
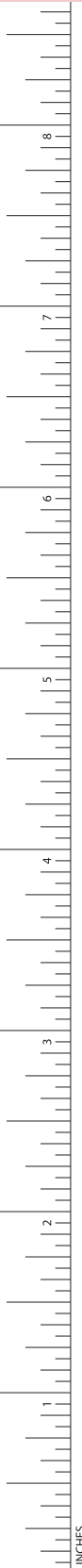

BM831R

BM832R

1/1

1/2

BRUNNER

BM831R-BM832R

Ligature needles

Agujas para ligadura

300 mm, 12"

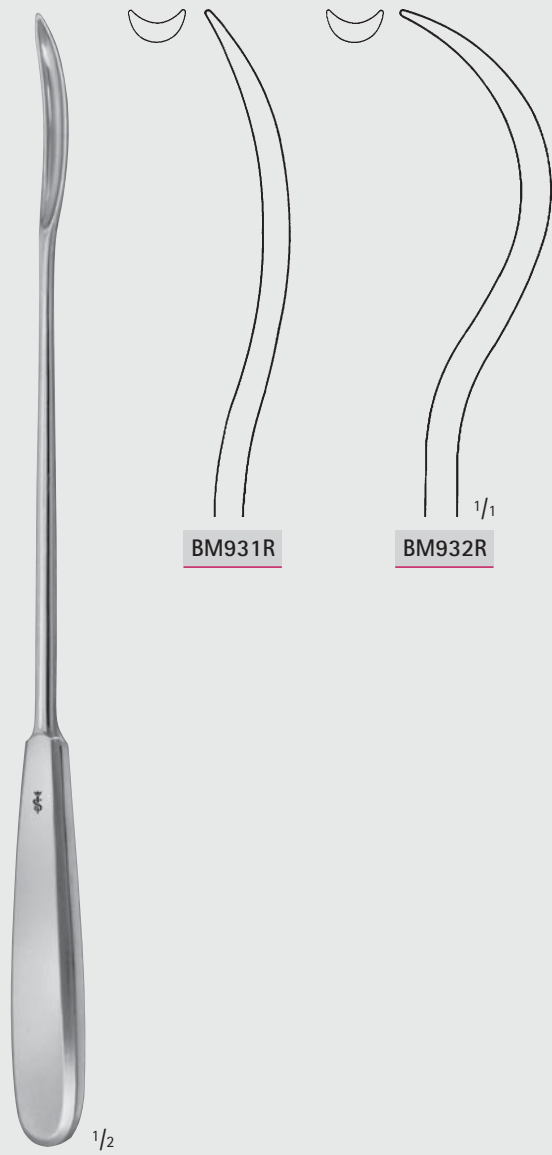

BM931R

BM932R

1/1

1/2

BRUNNER

BM931R-BM932R

Guiding probes

Sondas conductoras acanaladas

300 mm, 12"



Needle Holders - Portaaguja
Guiding Probes
Sondas conductoras acanaladas

BM

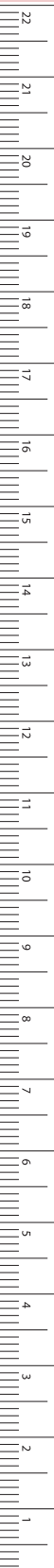

MILLIMETERS

3 mm

1/2 1/1

BM900R
200 mm, 8"

5 mm

1/2 1/1

KÖNIG
BM901R
195 mm, 7 3/4"

7 mm

1/2 1/1

KÖNIG
BM902R
200 mm, 8"

8 mm

1/2 1/1

SCHMIEDEN
BM905R
185 mm, 7 1/4"

11 mm

1/2 1/1

KOCHER
BM911R
150 mm, 6"

12 mm

1/2 1/1

KOCHER
BM913R
170 mm, 6 3/4"

5 mm

1/2 1/1

PAYR
BM920R
195 mm, 7 3/4"

5 mm

1/2 1/1

PAYR
BM922R
225 mm, 9"

Needle Holders - Portaaguja

Guiding Probes

Sondas conductoras acanaladas

Of plastic material, can be sterilized in an autoclave up to 143 °C (3 bar)

De material plástico, esterilizable en autoclave hasta 143° (3 bar)

BM

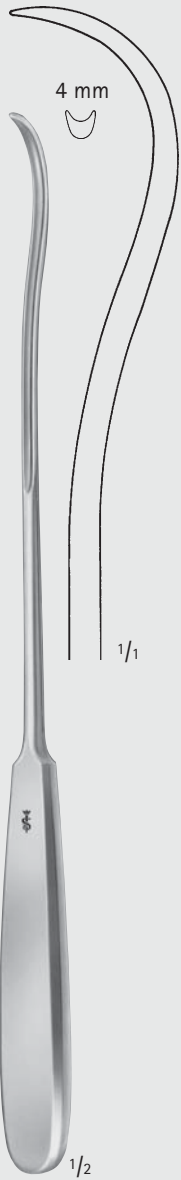

BM924R

280 mm, 11"



KIRSCHNER

BM925R

255 mm, 10"



BM938

240 mm, 9 1/2"

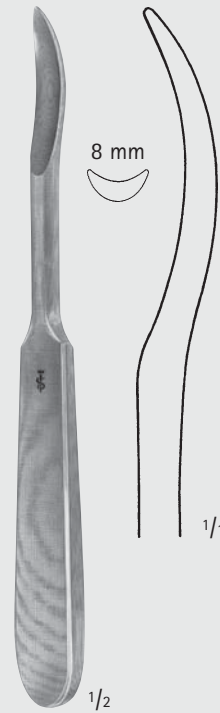

BM940

185 mm, 7 1/4"

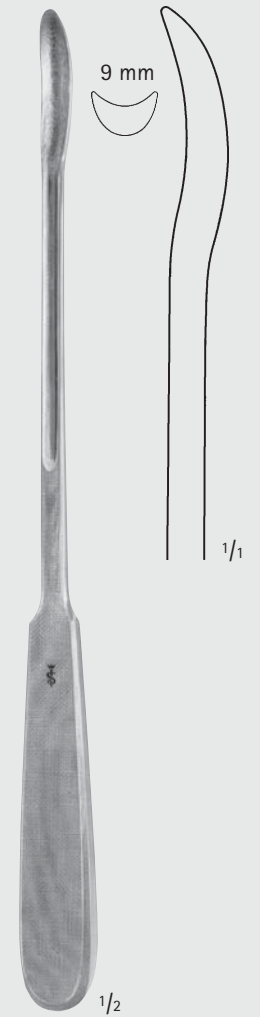

BM941

265 mm, 10 1/2"



Needle Holders - Portaagujas
Suture Instruments
Instrumentos para sutura

BM

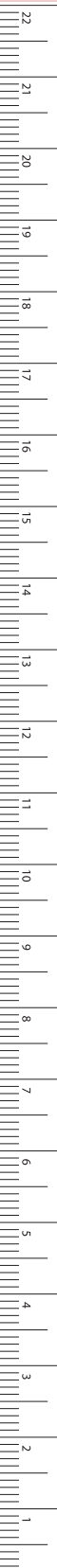

MILLIMETERS



BM950R

Knot tier and Ligature adjuster
Horquilla para hilos y ajustador para ligaduras
230 mm, 9"



CASPAR

FF309

Knot tier and Ligature adjuster
Horquilla para hilos y ajustador para ligaduras
230 mm, 9"