

ME Squared Enterprises, LLC
BUSINESS PLAN
For
Continuous Onboard Re-Charge Environment (CORE)



RE-CHARGE-EV

Raymond M. Folk
Founder / President / CEO

504 23rd St
Niceville, Florida 32578
8504965353
Ray@mesqent.com.com

CONFIDENTIAL & PROPRIETARY

Note: This transmission is intended solely for the use of the individual or entity to which it is address and may contain information that is proprietary, confidential, privileged and exempt from disclosure, under applicable laws.

I. EXECUTIVE SUMMARY

ME Squared Enterprises, LLC (“ME Squared” or the “Company”) is a Florida-based S-Corporation founded to commercialize a patented breakthrough in electric power and mobility technology. The Company is seeking strategic investment to complete product validation and bring its flagship technology—**Continuous Onboard Re-Charge Environment (CORE)**—to market.

CORE is a patented, onboard, mechanical-to-electrical power generation and charging system designed to **dramatically extend the operational range, endurance, and utility of electric and hybrid-electric vehicles and equipment**—without reliance on external charging infrastructure while in operation.

The technology is applicable across multiple high-growth markets, including:

- Electric and hybrid-electric automobiles
- Electric aircraft and aerospace propulsion systems
- Marine electric propulsion
- Portable, residential, commercial, and industrial electric generators

ME Squared Enterprises anticipates a **6–8 months development and validation timeline** post-funding and projects **break-even within 24–36 months** of commercial launch.

The Company is seeking **\$300,000 in initial funding** to acquire needed tools and equipment for the Company, with proceeds allocated toward engineering completion, prototyping, testing, staffing, and manufacturing readiness.

The Future of Electric Mobility with CORE

Imagine electric airliners flying around the globe without fuel stops, marine vessels traveling farther without refueling, and electric cars driving longer distances without frequent charging breaks. CORE technology promises to make this vision a reality, revolutionizing the electric transportation and power generation industries.

With ongoing research and development, CORE aims to become the gold standard for onboard charging solutions, supporting a cleaner, more efficient, and economically viable future for electric mobility worldwide.

Conclusion

The Continuous Onboard Re-Charge Environment (CORE) represents a groundbreaking advancement in electric vehicle technology. By enabling continuous charging during operation, CORE extends range, reduces costs, and supports environmental sustainability. As the global market for electric vehicles and electric propulsion systems expands, CORE is poised to play a pivotal role in shaping the future of clean energy transportation.

For investors, manufacturers, and consumers alike, CORE offers a compelling opportunity to embrace innovation that drives performance, profitability, and planet-friendly progress.

II. COMPANY OVERVIEW

Legal Structure & Formation

- **Entity:** ME Squared Enterprises, LLC
- **Structure:** Florida S-Corporation
- **Date of Formation:** February 28, 2022
- **Location:** Niceville, Florida

Current Staffing

- 2 Full-Time Executives

Extra Staffing (Needed)

- 5 - 9 Full-Time Employees

CONFIDENTIAL & PROPRIETARY

Note: This transmission is intended solely for the use of the individual or entity to which it is address and may contain information that is proprietary, confidential, privileged and exempt from disclosure, under applicable laws.

III. MANAGEMENT & LEADERSHIP

Raymond M. Folk – President & CEO

Mr. Folk is an RF/Microwave and Computer Engineer with **over 40 years of experience** in advanced electrical, radar, communications, and power systems design.

He has served as **Scientist & Engineer V / SME (Subject Matter Expert)** for a major U.S. defense contractor supporting the U.S. Air Force, where he designs next-generation communications platforms. His prior roles include **Primary Weather Radar Systems Upgrade Engineer** and lead engineer on complex defense and aerospace programs.

Mr. Folk brings:

- 40+ years in AC/DC, low- and high-voltage systems, and Radar Technologies
- 30+ years in computer networking and systems integration
- Direct collaboration with MIT Lincoln Laboratory, the U.S. Navy, U.S. Air Force, and federal agencies
- Hands-on experience in design, testing, prototyping, and system troubleshooting

He is the **inventor, primary engineer, and system architect** of CORE.

Amy E. Folk – Vice President & CFO

Mrs. Folk is a seasoned **Paralegal and Financial Administrator** with:

- 30+ years in accounting and bookkeeping
- 20+ years in legal and paralegal services

She oversees financial controls, compliance, contracts, and administrative operations, providing ME² with strong fiscal governance and regulatory discipline.

IV. PRODUCT & TECHNOLOGY OVERVIEW

CORE – Continuous Onboard Re-Charge Environment

CORE is a **portable, onboard, continuous charging system** that produces charging-equivalent electrical voltage while a vehicle or device is in motion. It is designed to replicate the electrical conditions of an external charging station—**without drawing energy from the vehicle's main battery array (MBA)**.

In practical terms, CORE® enables electric systems to:

- Operate **while being continuously recharged**
- Achieve **5x–10x increases in operational time or range**, depending on application and usage conditions
- Reduce or eliminate dependency on stationary charging infrastructure
- Lower total cost of ownership
- Significantly reduce emissions and fossil fuel dependence

How CORE Works (High-Level)

CORE converts mechanical rotational energy from an existing drive shaft or motor system into regulated electrical voltage that is then conditioned and amplified, to be equivalent to OEM charging sources. This voltage is delivered directly to the vehicle's existing charging architecture—allowing the battery to recharge while the system remains operational.

This principal mirrors how laptops and other electronics operate while plugged in, but applied at transportation and industrial scale.

Key Design Advantages

- Minimal to no OEM redesign required
 - Fail-safe operation: if CORE is disabled, the system reverts to standard OEM behavior
 - Adaptable to electric, hybrid-electric, and converted combustion platforms
 - Suitable for OEM integration or aftermarket installation
-

V. INTELLECTUAL PROPERTY

- **Patent Held:**
Continuous Onboard Re-Charge Environment (CORE)
U.S. Patent No. 11,635,477 B2

Additional patent and trademark protections may be pursued as commercialization progresses.

CONFIDENTIAL & PROPRIETARY

Note: This transmission is intended solely for the use of the individual or entity to which it is address and may contain information that is proprietary, confidential, privileged and exempt from disclosure, under applicable laws.

VI. MARKET OPPORTUNITY

ME Squared Enterprises, operates at the intersection of **renewable energy, electric mobility, and power generation**, all of which are experiencing sustained global growth.

Target Markets

- Electric & Hybrid Vehicles
- Electric Aviation & Aerospace
- Marine Electric Propulsion
- Portable & Standby Electric Generators
- Military Applications: (just a few)
 - Electric Aerospace Propulsion
 - Portable Power Carts Portable Light Carts
 - Electric cars and trucks
 - Electric All-Terrain Vehicles

The combined addressable market spans **tens of millions of units globally**, representing **hundreds of billions of dollars** in annual economic activity.

Across all segments, buyers consistently prioritize:

- Total cost of ownership
- Range and operational endurance
- Charging time and infrastructure availability
- Reliability and safety
- Environmental impact

CORE directly addresses these pain points.

VII. MARKETING & GO-TO-MARKET STRATEGY

Target Customers

- OEM manufacturers
- Fleet operators
- Defense, aerospace, and marine contractors
- Generator manufacturers and distributors
- Aftermarket retrofit markets

Distribution Strategy

- OEM integration partnerships
- Licensed manufacturing agreements
- Aftermarket product offerings

Promotional Strategy

- Industry trade shows and technical demonstrations
- Strategic OEM partnerships
- Digital, print, radio, and television advertising
- Government, defense, and clean-energy procurement channels

VIII. COMPETITIVE ANALYSIS (SWOT)

Strengths

- Patented, first-of-its-kind technology
- Broad multi-industry applicability
- Minimal integration complexity
- Significant cost, range, and efficiency advantages

Weaknesses

- Requires further prototyping and validation funding
- Performance optimized for active operation rather than idle conditions

CONFIDENTIAL & PROPRIETARY

Note: This transmission is intended solely for the use of the individual or entity to which it is address and may contain information that is proprietary, confidential, privileged and exempt from disclosure, under applicable laws.

Opportunities

- Rapid EV and electrification growth
- Increasing regulatory pressure on emissions
- Infrastructure limitations driving demand for onboard solutions

Threats

- Resistance from entrenched fossil fuel interests
- Regulatory certification timelines in aerospace and marine sectors

IX. FUNDING REQUEST & USE OF FUNDS

Capital Request

- **\$300,000 minimum investment or loan**
- **5%+ equity offered**, negotiable based on structure and strategic value

Use of Proceeds

- Completion of prototype and proof-of-concept testing
- Hiring key engineering and operational staff
- Acquisition of production equipment
- Facility leasing and setup
- Procurement of donor platforms for testing and demonstration
- Security

Item	Condition	Initial Exp
Electric Vehicle	New/Used	\$20,000.00
Electric Generator	Modified	\$10,000.00
Tools		\$5,000.00
Labor / Salaries (Monthly x 4)		\$80,000.00
Facilities Rental / Property Rental		\$8,000.00
Utilities		\$3,000.00
Computers/Software - R&D		\$20,000.00
Internet/Phone		\$1,500.00
Security (Physical/Video)		\$8,000.00
EV Charging Station x3	New/Used	\$3,000.00
Marketing		\$10,000.00
CAD/3D Printing - R&D		\$10,000.00
Attorney's Fees-Patent/Trademark		\$20,000.00
Website Development		\$10,000.00
Office Expenditures		\$3,000.00
Test Equipment	New/Used	\$40,000.00
Research/Development (R&D Testing)		\$10,000.00
Insurance / Health Insurance		\$10,000.00
Incidentals / Unforeseen Expenses		\$20,000.00
Totals:		\$291,500.00
Startup Totals:		\$291,500.00
Recurring Totals:		
Requested Investment/Grant Amount (Pre-Seed)		\$300,000.00
Requested Investment/Grant Amount - 2nd Rnd		\$500,000.00
Requested Investment Amount		\$1,000,000.00

CONFIDENTIAL & PROPRIETARY

Note: This transmission is intended solely for the use of the individual or entity to which it is address and may contain information that is proprietary, confidential, privileged and exempt from disclosure, under applicable laws.

X. FINANCIAL OUTLOOK

- **Development Timeline:** 6–8 months post-funding
- **Commercial Launch:** Year 1
- **Break-Even Target:** 24–36 months
- **Revenue Streams:**
 - OEM licensing
 - Unit sales
 - Aftermarket installations
 - Strategic partnerships

XI. VISION & CONCLUSION

ME Squared Enterprises envisions a future where electric transportation and power systems are no longer constrained by range, downtime, or infrastructure limitations and where reliance on oil and fossil fuels is dramatically reduced.

CORE has the potential to become the **gold standard** for onboard electric charging—transforming how vehicles, aircraft, vessels, and generators operate worldwide.

With proven leadership, protected intellectual property, and access to rapidly expanding markets, ME Squared represents a compelling opportunity for investors seeking participation in the next major evolution of electric power and mobility.

V. APPENDIX-1 - DIAGRAMS

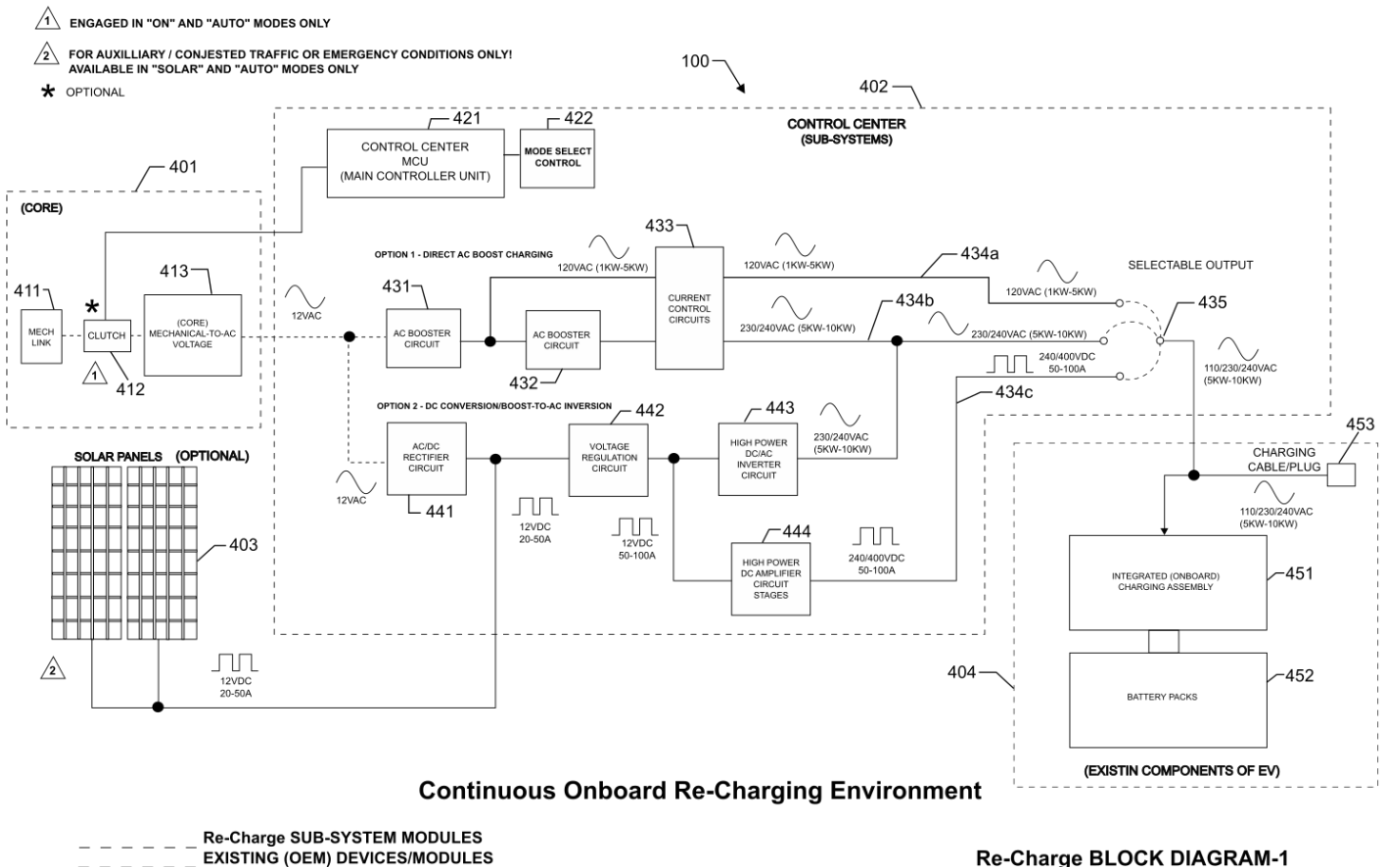

CCM Block Diagram 1

CONFIDENTIAL & PROPRIETARY

Note: This transmission is intended solely for the use of the individual or entity to which it is address and may contain information that is proprietary, confidential, privileged and exempt from disclosure, under applicable laws.

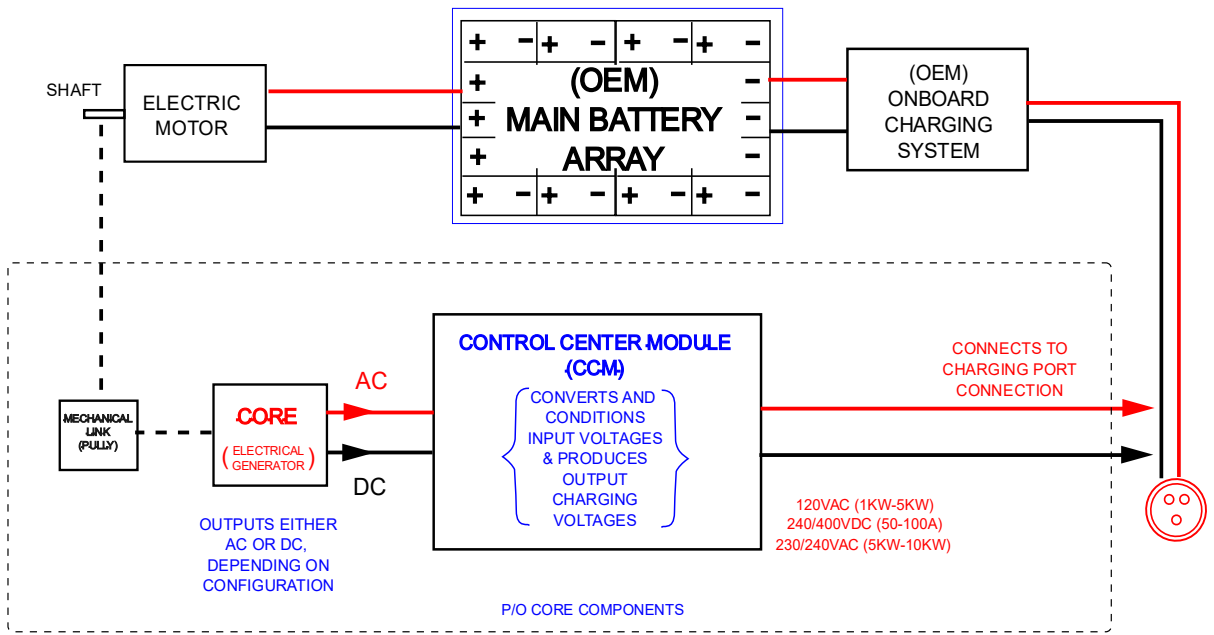

Basic Block Diagram

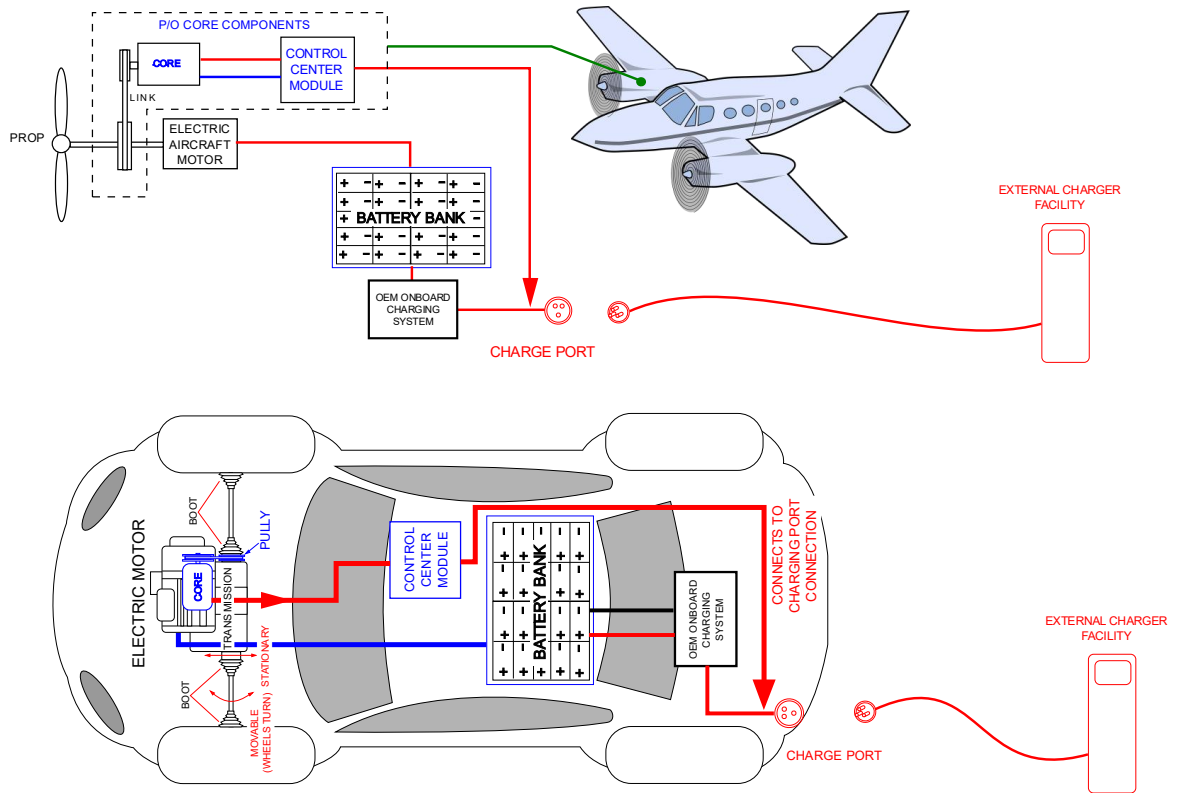

Assembly and Connection Block Diagram 1

CONFIDENTIAL & PROPRIETARY

Note: This transmission is intended solely for the use of the individual or entity to which it is address and may contain information that is proprietary, confidential, privileged and exempt from disclosure, under applicable laws.

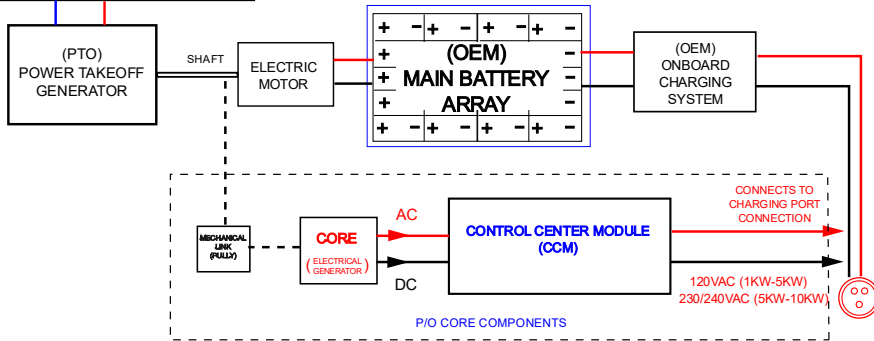
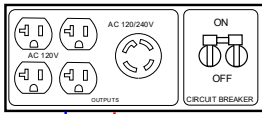
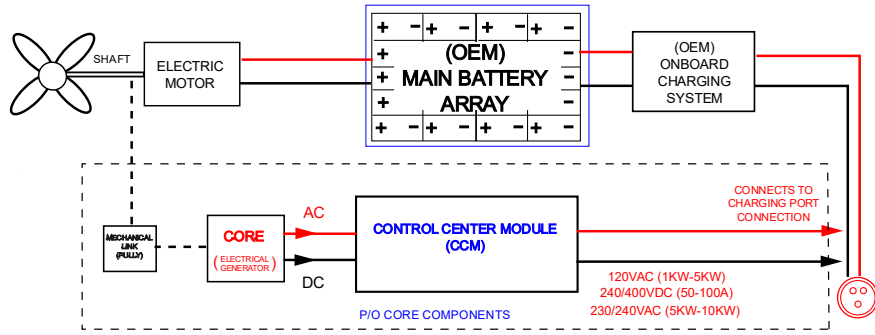

Assembly and Connection Block Diagram 2

CONFIDENTIAL & PROPRIETARY

Note: This transmission is intended solely for the use of the individual or entity to which it is address and may contain information that is proprietary, confidential, privileged and exempt from disclosure, under applicable laws.