

Improving safety *while* increasing production.

B&D Aluminum Step Platforms & Stairs

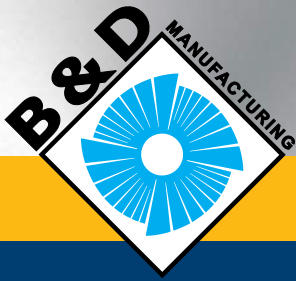



Improving safety *while* increasing production.



B&D Aluminum Step Platforms & Stairs

B&D Manufacturing's Aluminum Step Platforms & Stairs are designed and engineered to decrease set-up times and increase production in a variety of environments by minimizing the use of traditional fall protection equipment. These step platforms and stairs are designed to exceed industry standards in strength, safety, stability and product durability.

B&D is dedicated to providing products that help improve safety in the work environment while increasing production.

B&D Manufacturing offers a wide range of light to heavy duty, standard or custom step platforms and stairs to suit a variety of applications.

Choose from these options or make a custom order.

- ✓ **ASP** Aluminum Step Platforms: 1 – 5 Step 3
- ✓ **ARSP** Aluminum Rolling Step Platforms: 4 – 10 Step 4
- ✓ **AMPS** Aluminum Manually Propelled Stairs 5
- ✓ **AMPS-30-XXX-SP** Aluminum Fuel Tank Stairs 6
- ✓ **AMPS-19.5-88-WP-SP** Aluminum Hoist Cylinder Stair 7
- ✓ **AMPS-30-90-SP** Aluminum Dozer/Excavator Track Access Stair 8
- ✓ **AMPS-24-116-164-EP** Aluminum Elevating Platform Stair 10



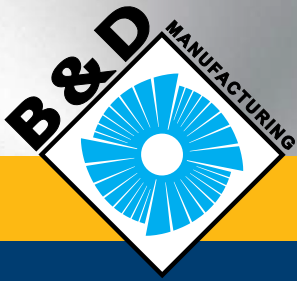

1-800-668-0324
 Outside Canada and the US: 1-705-855-2363



Aluminum Step Platforms

ASP-X

1 Step – 5 Step Models

ASP-X-HR

2 Step – 5 Step Models with Hand Railings

X = # of Steps

B&D's ultra-light duty **Aluminum Step Platforms** are fabricated in a full weldment design. These can be easily moved into position with little effort. They are ideal for quick maintenance work in and around equipment. Superior shur-grip steps and top platform provide an anti-slip surface to withstand all weather conditions.

- Engineer Certified, 300-lb load rating
- Fabricated in lightweight aluminum
- Superior shur-grip steps for anti-slip surface

Optional handrail versions for all models.

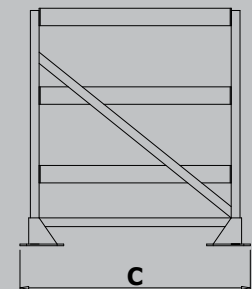
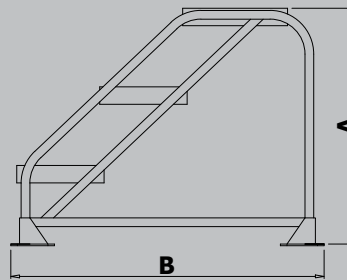

PART #	A	B	C	TOP PLATFORM SIZE	WEIGHT
ASP-1	9"	15 ½"	27"	12" x 24"	8 lbs
ASP-2	18"	24 ½"	26 ½"	12" x 22"	17 lbs
ASP-3	27"	36"	26 ½"	12" x 22"	25 lbs
ASP-4	36"	45 ½"	26 ½"	12" x 22"	32 lbs
ASP-5	45"	55"	26 ½"	12" x 22"	39 lbs

Add -HR to Part # : Optional Hand Railings Available (Welded to Platform)

ALUMINUM STEP PLATFORMS

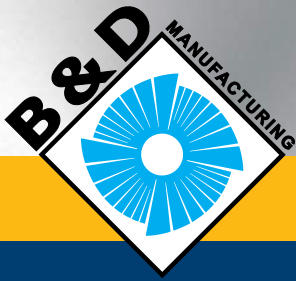

Improving safety *while* increasing production.



Aluminum Rolling Step Platforms

ARSP-X-HR

4 Step – 10 Step Models

X = # of Steps

B&D's lightweight medium duty **Aluminum Rolling Step Platforms** feature rolling capabilities for easy positioning, bolt-on replaceable components, standard 42" tall hand railings on all models, and a large top work platform. Superior shur-grip steps and top platform provide an anti-slip surface to withstand all weather conditions.

- Engineer Certified, 500-lb load rating
- Fabricated in lightweight high-strength aluminum
- Hinged front and back safety bars with locking pin
- Bolt-on replaceable hand railings included with all models
- 2 wheels for ease of mobility
- Superior shur-grip steps and top platform for anti-slip surface
- Grade 8 zinc plated fasteners

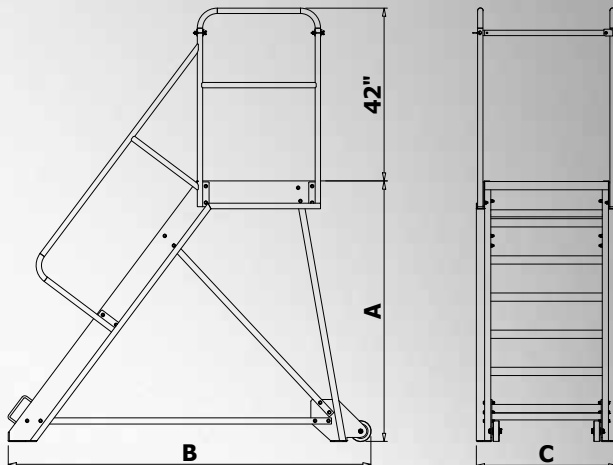

PART #	A	B	C	TOP PLATFORM SIZE	WEIGHT
ARSP-4-HR	36"	63"	34"	30" x 30"	105 lbs
ARSP-5-HR	45"	71 ½"	34"	30" x 30"	115 lbs
ARSP-6-HR	54"	79 ½"	34"	30" x 30"	127 lbs
ARSP-7-HR	63"	88"	34"	30" x 30"	137 lbs
ARSP-8-HR	72"	95"	34"	30" x 30"	147 lbs
ARSP-9-HR	81"	103"	40"	36" x 30"	170 lbs
ARSP-10-HR	90"	111 ½"	40"	36" x 30"	180 lbs

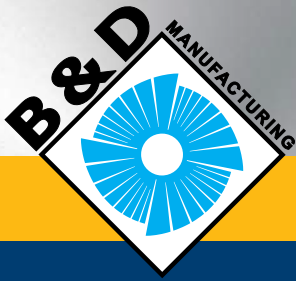

1-800-668-0324
 Outside Canada and the US: 1-705-855-2363



Aluminum Manually Propelled Stairs AMPS-XX-XXX

Aluminum Stairs Series

XX = Width (30" Standard), XXX = Height, -SP = Special Request

Custom options available

B&D's heavy duty **Aluminum Manually Propelled Stairs** are our biggest and strongest stairs available, taking it one step further than the industry standard by offering greater stability and safety. These stairs feature urethane on cast high capacity casters for easy positioning, bolt-on replaceable components, standard 42" tall hand railings on all models, and a large top work platform. Superior shur-grip steps and top platform provide an anti-slip surface to withstand all weather conditions.

- Engineer Certified, 500-lb load rating
- Heavy duty design, fabricated in lightweight high-strength aluminum
- Hinged front and back safety bars with locking pin
- Modular design, all components replaceable
- 2 swivel casters and 2 rigid casters for ease of mobility and positioning
- 2 front floor locks, 2 rear leveling outriggers for stability
- Integral 8" x 4" fork pockets for transporting, 40" centre
- Superior 7" x 30" shur-grip steps and top platform for anti-slip surface
- Grade 8 zinc plated fasteners

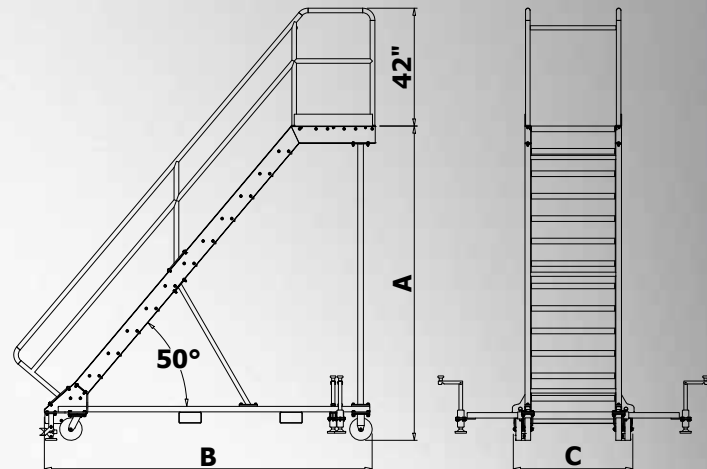

PART #	A	B	C	TOP PLATFORM SIZE	WEIGHT
AMPS-30-99	99"	90"	43 1/2"	30" x 30"	500 lbs
AMPS-30-108	108"	96"	43 1/2"	30" x 30"	520 lbs
AMPS-30-117	117"	102"	43 1/2"	30" x 30"	540 lbs
AMPS-30-126	126"	108"	43 1/2"	30" x 30"	560 lbs
AMPS-30-135	135"	114"	43 1/2"	30" x 30"	580 lbs
AMPS-30-144	144"	120"	43 1/2"	30" x 30"	600 lbs

Customized options available
 (e.g. larger top platform, custom hand rails, etc.)

ALUMINUM MANUALLY PROPELLED STAIRS

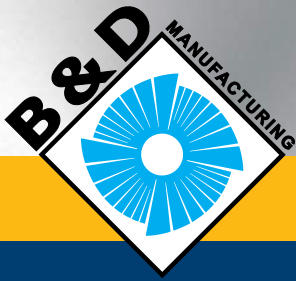

Improving safety *while* increasing production.



ALUMINUM FUEL TANK STAIRS

Aluminum Fuel Tank Stairs

AMPS-30-XXX-SP

XXX = Height, SP = 8" Step Rise, SP9 = 9" Step Rise

B&D's heavy duty **Aluminum Fuel Tank Stairs** have the same characteristics as our Aluminum Manually Propelled Stairs product line, but with added features. This is the industry's first stair to safely allow access to the frame of many common haul trucks by way of a hinged boarding ramp that rests on the fuel tank. Slide-out hand railings provide lateral fall protection while accessing the frame. These stairs feature urethane on cast high capacity casters for easy positioning, bolt-on replaceable components, standard 42" tall hand railings on all models and a large top work platform. Superior shur-grip steps and top platform provide an anti-slip surface to withstand all weather conditions.

These stairs work in conjunction with the Frame Fall Protecting Hand Railing. Call B&D for details.

- Engineer Certified, 500-lb load rating
- Heavy duty design, fabricated in lightweight high-strength aluminum
- Modular design, all components replaceable
- 2 swivel casters and 2 rigid casters for ease of mobility and positioning
- 2 front floor locks, 2 rear leveling outriggers for stability
- Integral 8" x 4" fork pockets for transporting, 40" centre
- Superior 7" x 30" shur-grip steps and top platform for anti-slip surface
- Slide-out hand railings and hinged extensions
- Hinged boarding ramp
- Grade 8 zinc plated fasteners
- Custom options available

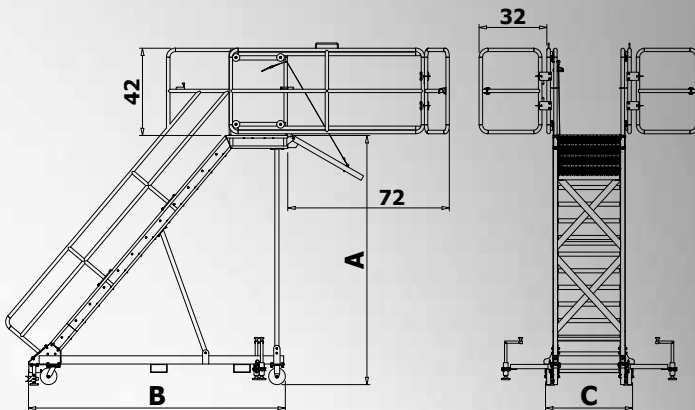
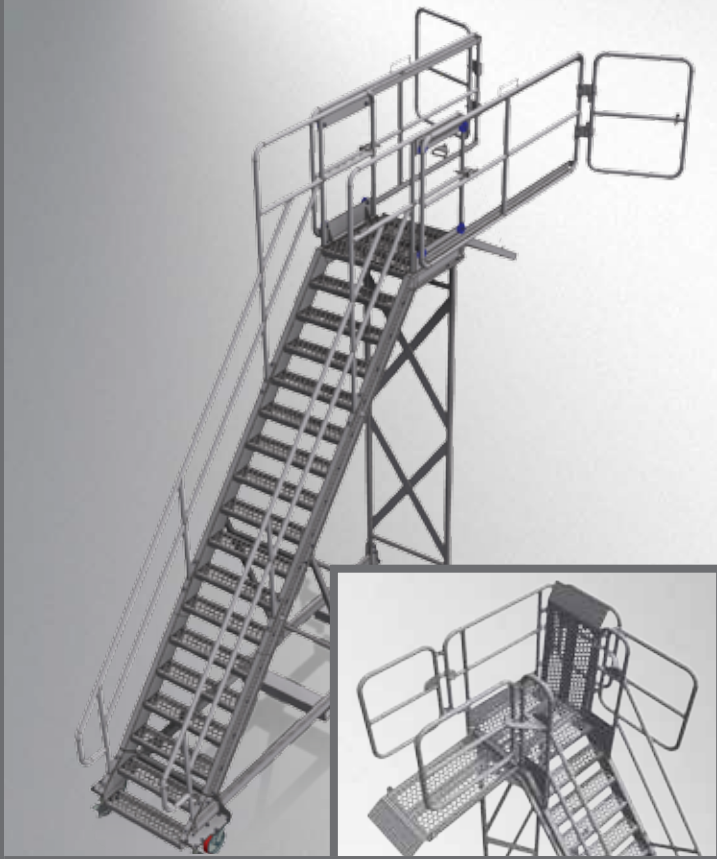

PART #	A	B	C	TOP PLATFORM SIZE	WEIGHT
AMPS-30-104-SP	104"	110 1/2"	42"	30" x 30"	680 lbs
AMPS-30-108-SP9	108"	96"	42"	30" x 30"	670 lbs
AMPS-30-112-SP	112"	117"	42"	30" x 30"	700 lbs
AMPS-30-117-SP9	117"	102"	42"	30" x 30"	690 lbs
AMPS-30-120-SP	120"	124"	42"	30" x 30"	720 lbs
AMPS-30-126-SP9	126"	108"	42"	30" x 30"	710 lbs
AMPS-30-128-SP	128"	130 1/2"	42"	30" x 30"	740 lbs
AMPS-30-135-SP9	135"	114"	42"	30" x 30"	730 lbs
AMPS-30-136-SP	136"	137"	42"	30" x 30"	760 lbs
AMPS-30-144-SP	144"	120"	42"	30" x 30"	750 lbs
AMPS-30-144-SP9	144"	144"	42"	30" x 30"	780 lbs

For side access option add – SA to part #

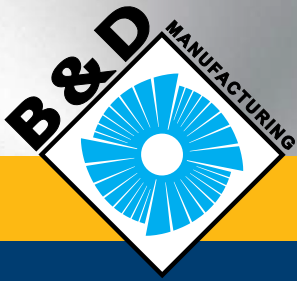

1-800-668-0324
Outside Canada and the US: 1-705-855-2363



Aluminum Hoist Cylinder Stair

AMPS-19.5-88-WP-SP

Footprint: 24"W x 116"L x 88"H

Weight: 490 lbs

B&D's **Aluminum Hoist Cylinder Stair** is a narrow-designed aluminum stair that is application specific, fitting in between the fuel/hydraulic tanks and tires to access the hoist cylinder during maintenance.

- Engineer Certified, 500-lb load rating
- Fabricated in lightweight high-strength aluminum
- 2 swivel casters and 2 rigid casters for ease of mobility and positioning
- 2 front floor locks, 2 rear leveling outriggers for stability
- Right-side and left-side hinged 22 1/2" x 40 1/2" resting platforms
- Adjustable back slide bars to contour the cylinder to prevent fall hazard
- Integral 8" x 4" fork pockets for transporting, 36" centre
- Superior 7" x 19 1/2" shur-grip steps and 19 1/2" x 48" top platform for anti-slip surface
- Grade 8 zinc plated fasteners

ALUMINUM HOIST CYLINDER STAIR

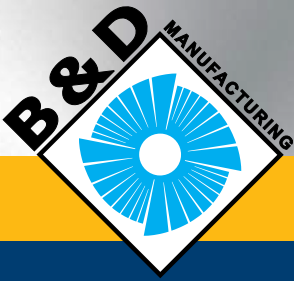

Improving safety *while* increasing production.



Aluminum Dozer/Excavator Track Access Stair

AMPS-30-90-SP

Footprint: 43"W x 87"L x 90"H

Weight: 1075 lbs

B&D's Aluminum Dozer/Excavator Track Access Stair features a large cantilever platform. This design allows a safe unobstructed path over track assemblies to access cab or to perform routine maintenance around tracked equipment. This stair features urethane on cast high capacity casters for easy positioning, bolt-on replaceable hand railings, steps and ramps, and standard 42" tall hand railings. Superior shur-grip steps and top platform provide an anti-slip surface to withstand all weather conditions.

- Engineer Certified, 500-lb load rating
- Fabricated in lightweight high-strength aluminum
- Large 30" x 74" cantilever top platform for over-the-track access
- Steel counterweight provides exceptional unsupported counter balance
- 2 swivel casters and 2 rigid casters for ease of mobility and positioning
- 2 front floor locks, 2 rear leveling outriggers for stability
- Right-side and left-side hinged 22" x 45" ramps to access tracks
- Removable back handrail section
- Swing out handrails for ramps
- Superior shur-grip steps for anti-slip surface
- Integral 8" x 4" fork pockets for transporting, 40" centre
- Grade 8 zinc plated fasteners



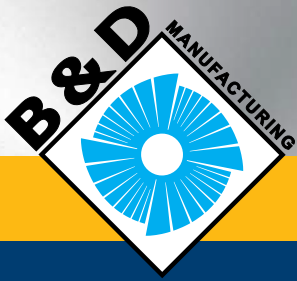

1-800-668-0324
Outside Canada and the US: 1-705-855-2363



ALUMINUM DOZER/EXCAVATOR TRACK ACCESS STAIR

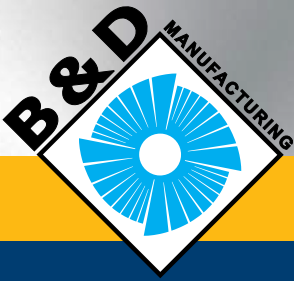

Improving safety *while* increasing production.



ALUMINUM ELEVATING PLATFORM STAIR

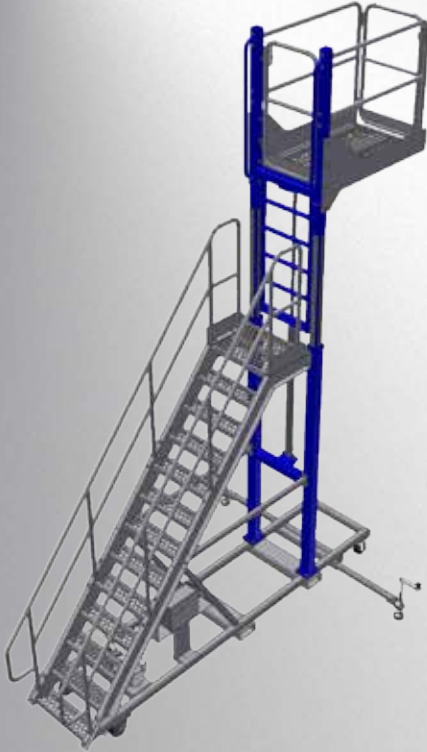

Aluminum Elevating Platform Stair

AMPS-24-116-164-EP

Footprint: 34"W x 143"L x 116" to 164"H

Weight: 1250 lbs

B&D's **Aluminum Elevating Platform Stair** is a hybrid aluminum/ steel manufactured stair that can be remotely raised from a lowered height of 116" to a maximum height of 164" by either the top platform or the ground level master control panel. This stair is ideal for maintenance work at various heights.

- Engineer Certified, 500-lb load rating
- Fabricated in lightweight high-strength aluminum
- Large 30" x 48" cantilever top platform with front and back gates
- Equipped with 6" x 3" phenolic wheel casters for low resistance, which makes for easy maneuverability
- 2 leveling outriggers for stability
- Superior shur-grip steps for anti-slip surface
- Integral 8" x 4" fork pockets for transporting, 36" centre
- Onboard 110 V.A.C. hydraulic power pack equipped with a Washguard motor which is suitable for wet locations and capable of withstanding direct water spray
- Radio frequency control for up/down/e-stop equipment control from the upper platform area
- Main control panel mounted at ground level and equipped with control overrides for master control of equipment in the event of an emergency
- Lowered height of elevated platform is 116"; raised height is 164"
- Grade 8 zinc plated fasteners



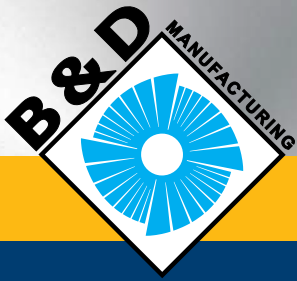

1-800-668-0324
Outside Canada and the US: 1-705-855-2363



ALUMINUM ELEVATING PLATFORM STAIR



Your local distributor:



Founded in 1980, B&D Manufacturing is a dynamic Canadian company that designs, manufactures and distributes innovative products and technologies to increase production and improve safety for industries globally. Our line includes products designed to support equipment for mines & mills, open pit trucks and shovels and construction. In addition to our OEM product line, we support a variety of clients with custom design, fabrication and manufacturing, on-site repair and rebuild services.

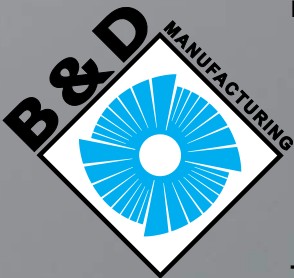

Improving safety *while* increasing production.

Toll-free in the US or Canada:

1-800-668-0324

Other countries phone:

1-705-855-2363

www.bdmfg.com

B&D Manufacturing, Chelmsford, Ontario, Canada

