

Helping industry succeed with every turn.

## B&D Super Jack

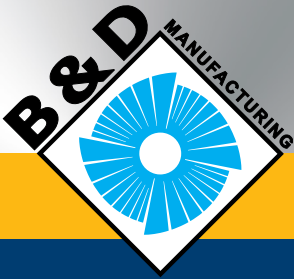



Helping industry succeed with every turn.



TRUCK & SHOVEL SAFETY PRODUCTS



- Connectors are used for wiring harnesses.
- Operator's console uses state-of-the-art components.



Visit our web site: [www.bdmfg.com](http://www.bdmfg.com)

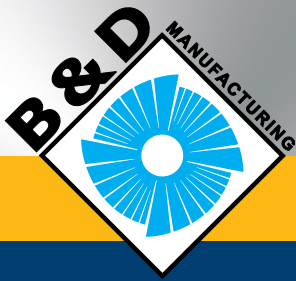

1-800-668-0324  
Outside Canada and the US: 1-705-855-2363

## Increase availability to your trucks by minimizing maintenance downtime using existing shop floor space with the B&D Super Jack.

When maintenance is required on your fleet, this sturdy and dependable device can lift and secure the largest haulage trucks in the world. For excellent stability when pulling tires and wheel groups from trucks, we offer three models:

**BD-SJ120** - 10.5 ton machine with a footprint of 25.5 square feet provides great stability for a 300 ton series truck.

**BD-SJ240** - 12.5 ton machine with a footprint of 33.6 square feet provides great stability for a 400 ton series truck.

**BD-SJ240-U** - 11.5 ton machine with a footprint of 30.8 square feet provides great stability for 300 and 400 ton series trucks.

This is the only certified two point lift Jacking System for the 300 to 400 ton trucks.

The B&D Super Jack enables workers to perform the required maintenance to your vehicles in a secure and safe environment. Easy to operate requiring only one individual, the Super Jack can perform it's task in four simple steps:

1. Drive the Super Jack into position.
2. Hydraulically lift the truck.
3. Hydraulically insert locking pins.
4. Perform tag and lock-out procedure.

The Super Jack can double as a safety stand while the work is being done on the truck and if you need to use it to lift other vehicles simply replace it with a pair of custom engineered B&D Safety Stands.

The Super Jack is a fully computer controlled, hydraulically driven vehicle. It can sense the characteristics of the lift with a feedback screen that enables the operator to visually monitor the vehicle tonnage, tilt and limits.

### Custom lifting attachments for your fleet

Custom lifting attachments can be designed for lifting your specific trucks. Call today to discuss your requirements.

### Servicing

Your B&D Super Jack is backed by B&D's One-Year Service Warranty Policy. In addition, it comes with a fully equipped service manual. B&D's skilled technicians are available for Field Commissioning and Service Maintenance.



- Engine easily accessible for maintenance via scissor-lift

Visit our web site: [www.bdmfg.com](http://www.bdmfg.com)

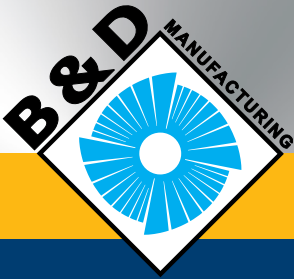

Helping industry succeed with every turn.



• All dimensions are approximate

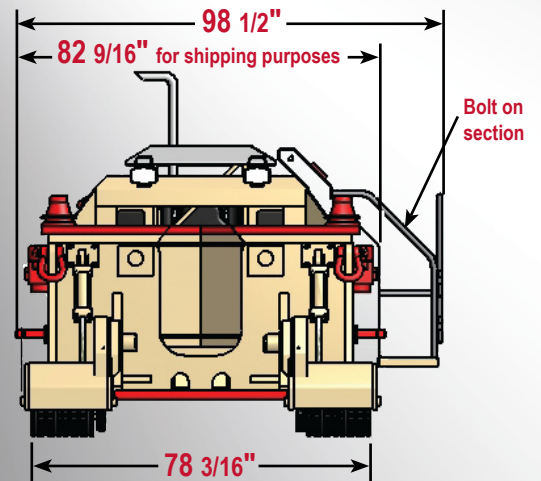
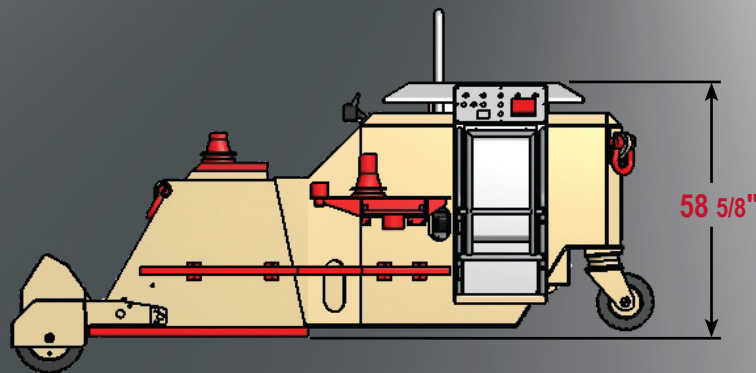
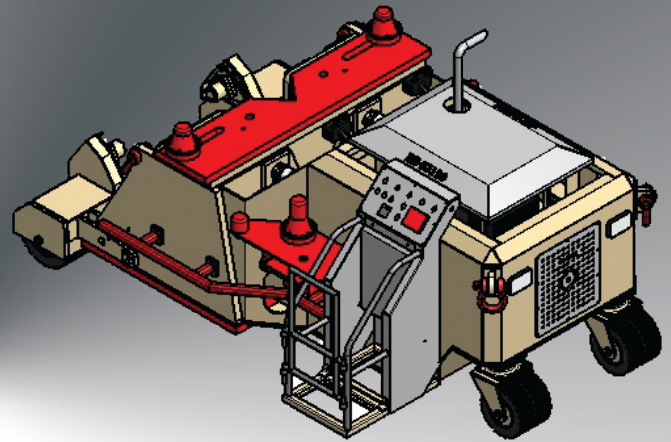
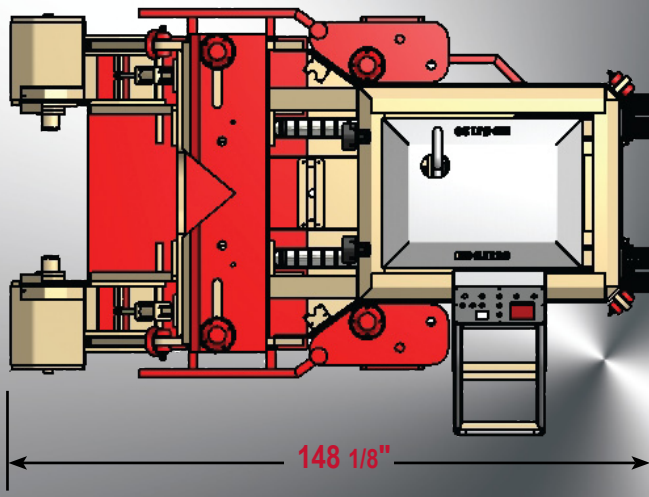

SUPER JACK 120 TECH SPECS

Visit our web site: [www.bdmfg.com](http://www.bdmfg.com)

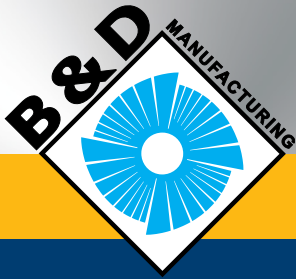

1-800-668-0324  
Outside Canada and the US: 1-705-855-2363

• All dimensions are approximate

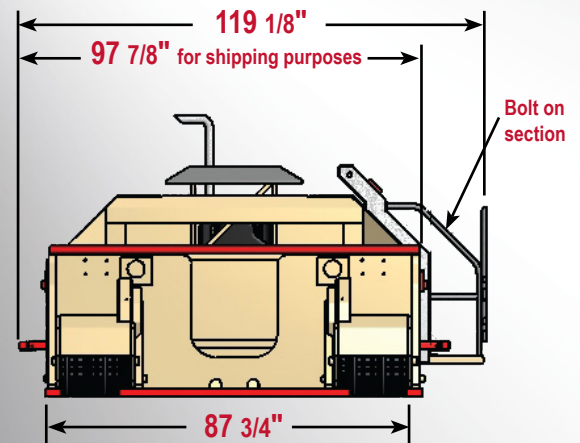
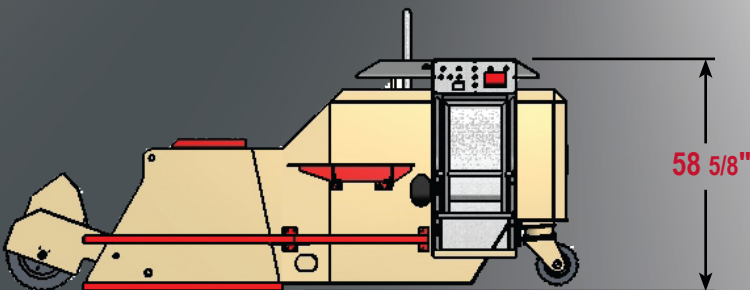
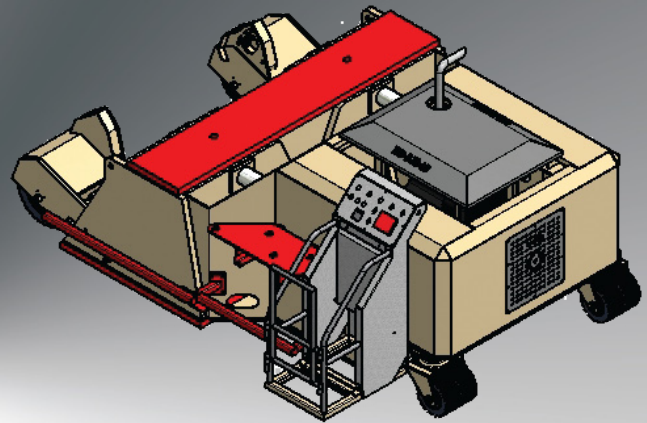
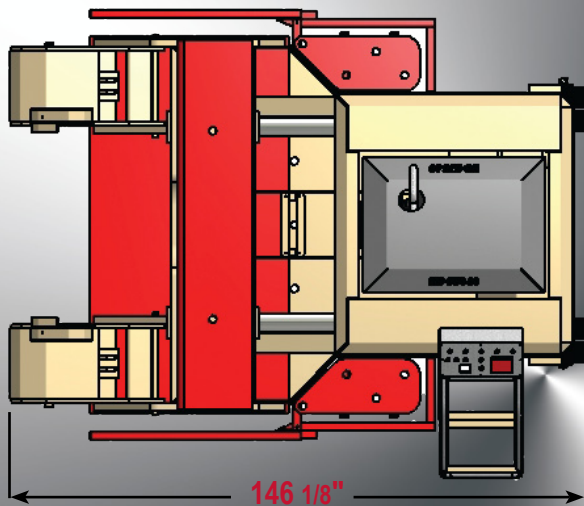

SUPER JACK 240 TECH SPECS

Visit our web site: [www.bdmfg.com](http://www.bdmfg.com)

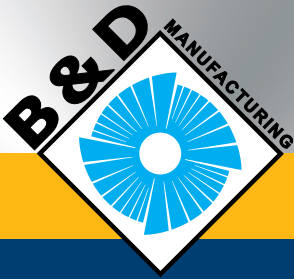

Helping industry succeed with every turn.



• All dimensions are approximate

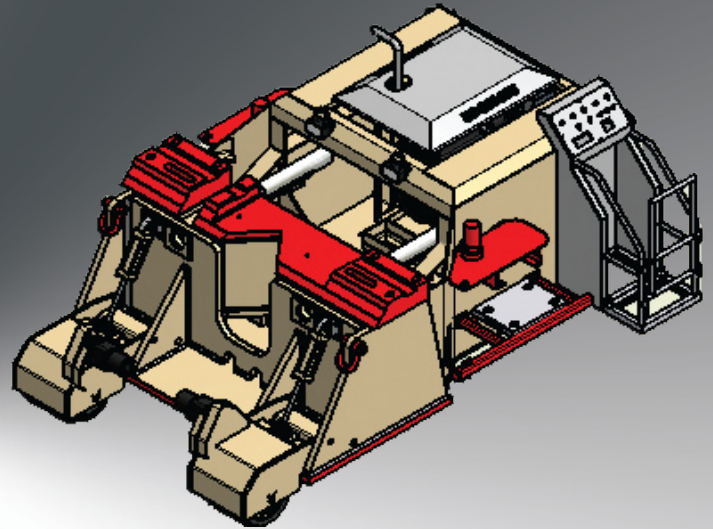
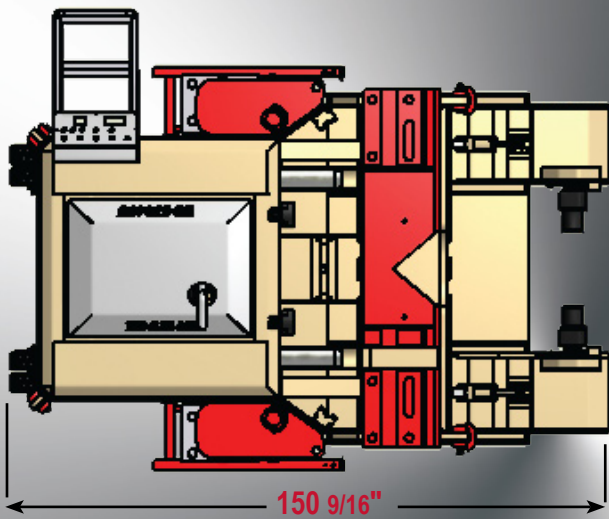

SUPER JACK 240U TECH SPECS

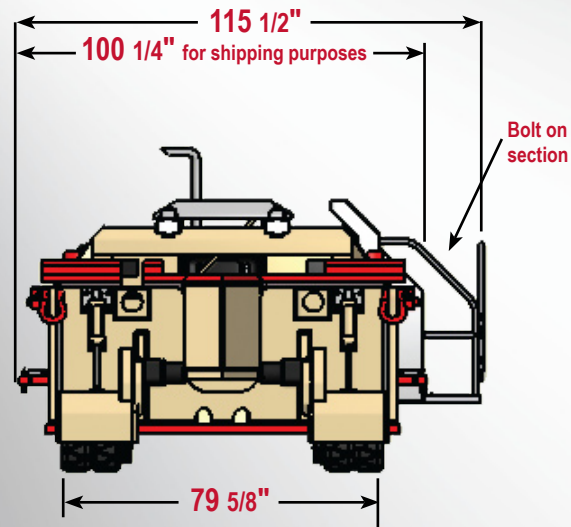
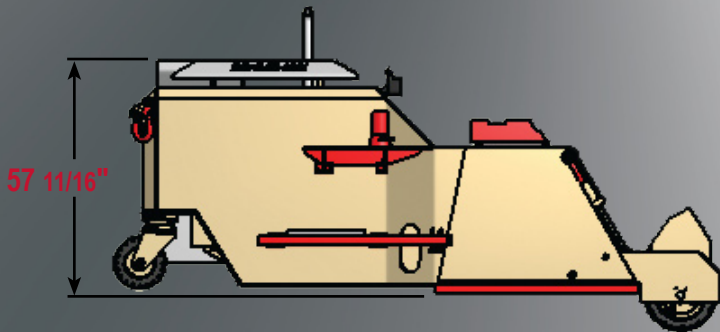

Visit our web site: [www.bdmfg.com](http://www.bdmfg.com)

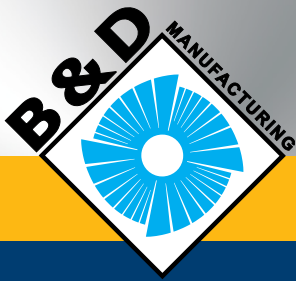

1-800-668-0324  
Outside Canada and the US: 1-705-855-2363

## Super Jack

### BD-SJ120

- Engineered with a 72" body
- Gross vehicle weight 21,000 lbs. with accessories

### BD-SJ240

- Engineered with a 96" body
- Gross vehicle weight 25,000 lbs. with accessories

### BD-SJ240U

- Engineered with a 88" body
- Gross vehicle weight 23,000 lbs. with accessories

## Features

- Mechanical frame is designed to support 600 tons
- Parker Hydraulic System and IQAN Control Package
- Proportional hydraulic valves
- 12 VDC control wiring
- Pressure and level sensing
- Vehicle tilt warning
- Hydraulic skid steer with emergency brakes
- Working lights for operator
- Custom lifting attachments for variable trucks

## Hydraulic power source

- closed center, load sense piston pump
- 25 US gallon hydraulic reservoir
- 17 GPM
- 3000 PSI
- 5 micron absolute pressure and return filtration

## Diesel motor

- YANMAR 3 cylinder diesel engine
- 25 HP at 2000 RPM
- Tier 4 emission standards

### B&D Truck Maintenance Support Equipment Package

Be sure to find out how B&D can increase availability to your trucks by minimizing downtime using existing shop floor space by acquiring this unique package:

- B&D Multi Handler
- B&D Super Jack
- B&D Tire Handler Station
- Spreader Bar
- Work Platforms
- Wheel Chocks
- Safety Stands
- Effluent tanks



Your local distributor:



Founded in 1980, B&D Manufacturing is a dynamic Canadian company that designs, manufactures and distributes innovative products and technologies to increase production and improve safety for industries globally. Our line includes products designed to support equipment for mines & mills, open pit trucks and shovels and construction. In addition to our OEM product line, we support a variety of clients with custom design, fabrication and manufacturing, on-site repair and rebuild services.

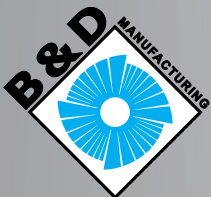

**Helping industry succeed with every turn.**

Toll-free in the US or Canada:

**1-800-668-0324**

Other countries phone:

**1-705-855-2363**

**[www.bdmfg.com](http://www.bdmfg.com)**

B&D Manufacturing, Chelmsford, Ontario, Canada