

Helping industry succeed with every turn.

B&D Multi Handler

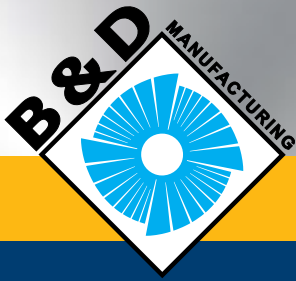



Helping industry succeed with every turn.



MULTI HANDLER



1-800-668-0324
Outside Canada and the US: 1-705-855-2363

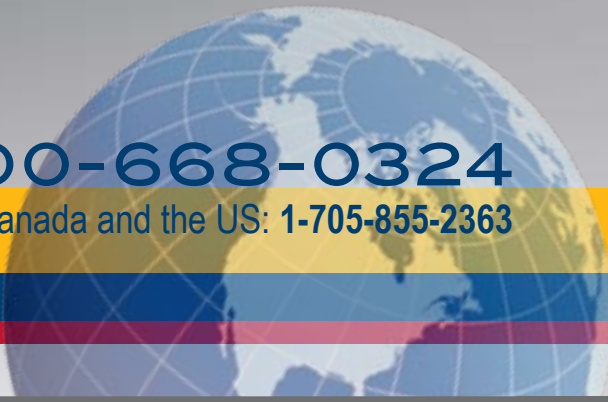

MULTI HANDLER

Visit our web site: www.bdmfg.com

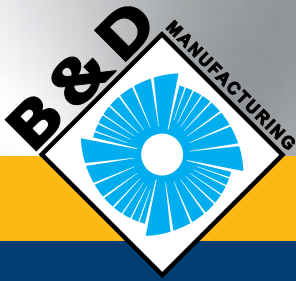

Helping industry succeed with every turn.



MULTI HANDLER

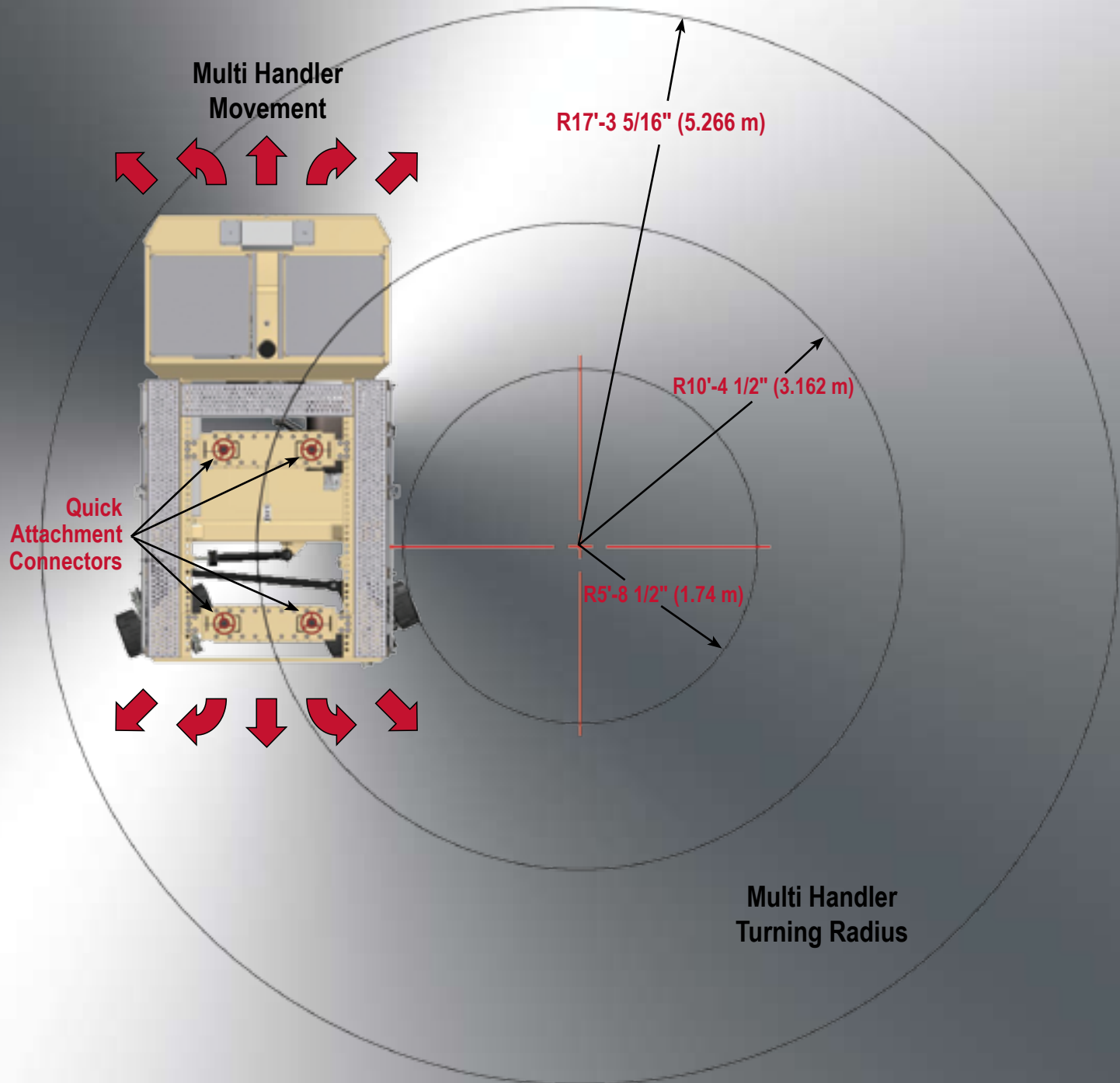

*DC Model Shown



1-800-668-0324
Outside Canada and the US: 1-705-855-2363

Increase availability to your trucks by minimizing maintenance downtime using existing shop floor space with the B&D Multi Handler.

This specially designed tool is a must! It is designed and manufactured for the mechanics on the floor and will tremendously increase safety and turn around time on wheel motor repairs. Designed for haulage truck wheel motors manufactured by Caterpillar, Komatsu, and Liebherr. Completely engineered, certified and supported by B&D Manufacturing and partners.

Custom design

B&D can custom design models to fit your fleet requirements.

Servicing

Your B&D Multi Handler is backed by B&D's One-Year Service Warranty Policy. In addition, it comes with a fully equipped service manual. B&D's skilled technicians are available for Field Commissioning and Service Maintenance.

Special features:

- Certified heavy duty frame holds 50 tons
- Allows wheel motor to rotate on cradle cams
- Gives complete movement to wheel motor X, Y, Z, Yaw, Pitch and Roll
- Computer controlled
- Diesel, DC Battery or AC powered 30 HP
- Radio remote control
- 6 all wheel drive, heavy duty grip, aggressive traction tires
- All three drive assemblies steer 45 degrees
- Work platform

Optional equipment:

- Front strut removing tool attachment
- Rear strut removing tool attachment
- Main body hydraulic cylinder removing tool attachment
- Hydraulic and fuel tank removing tool attachment
- Rear differential removing tool attachment
- Spindle hub brake removing tool attachment



*DC Model Shown

MULTI HANDLER

Visit our web site: www.bdmfg.com

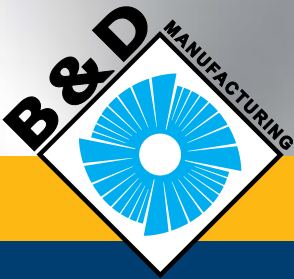

Helping industry succeed with every turn.



DIESEL MULTI HANDLER TECH SPECS

- All dimensions are approximate
- Approximate gross weight: **21,000 lbs.**

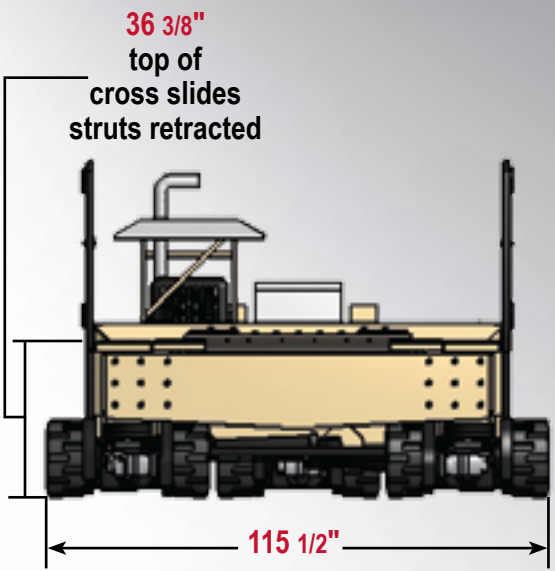
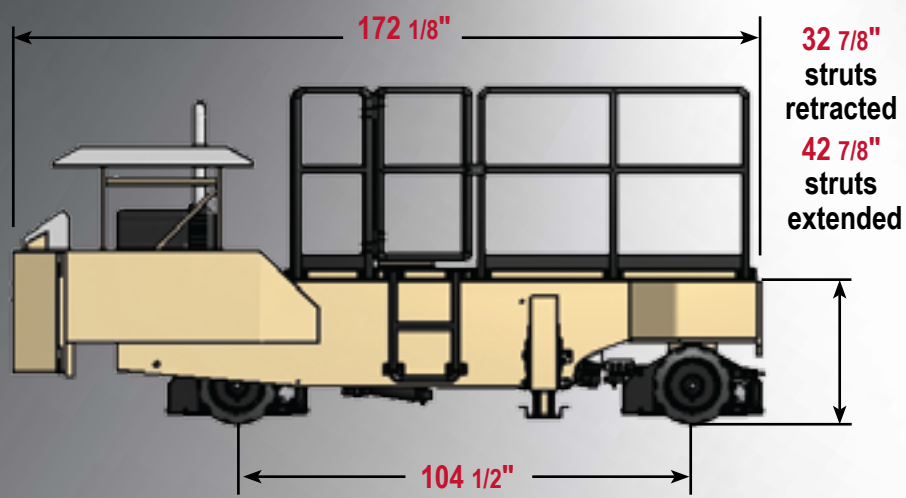
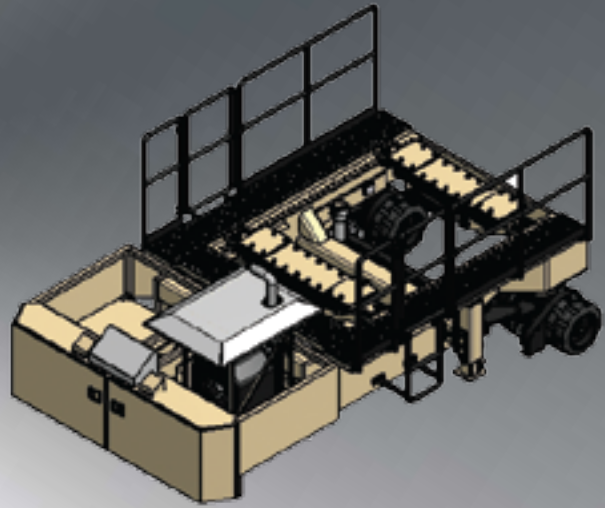
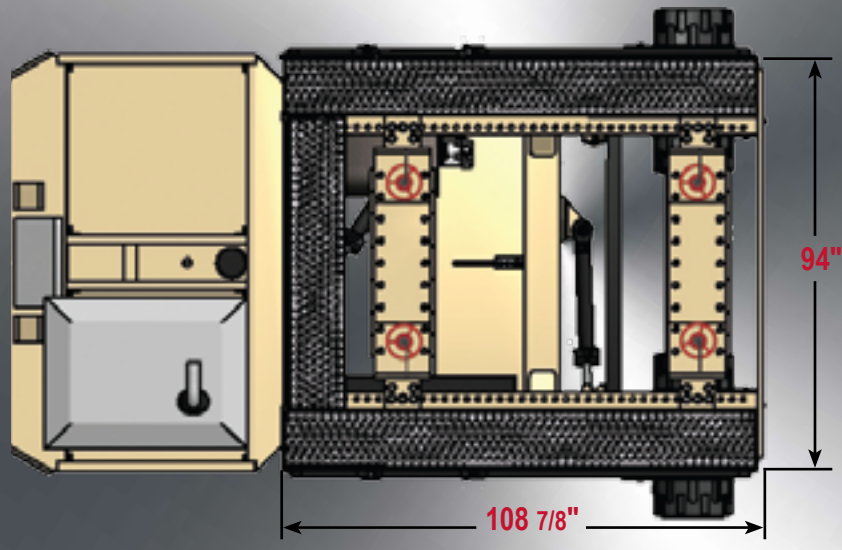

Visit our web site: www.bdmfg.com



1-800-668-0324
 Outside Canada and the US: 1-705-855-2363

- All dimensions are approximate
- Approximate gross weight: **21,000 lbs.**

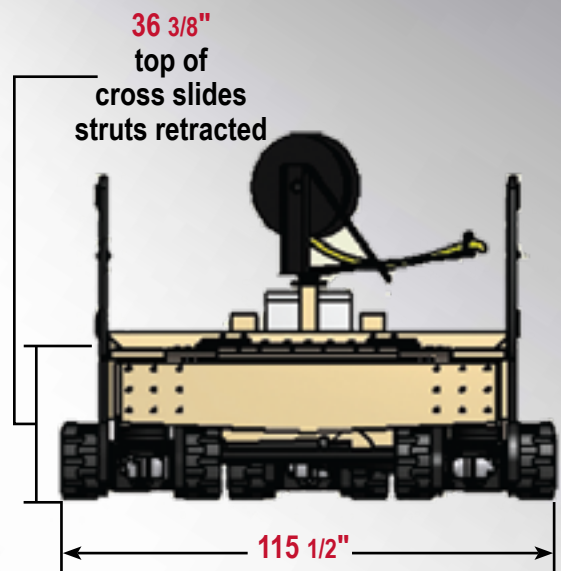
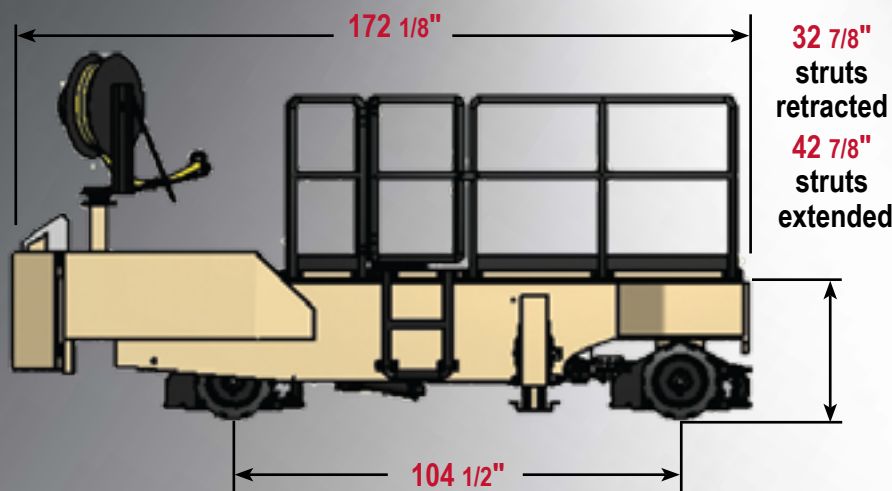
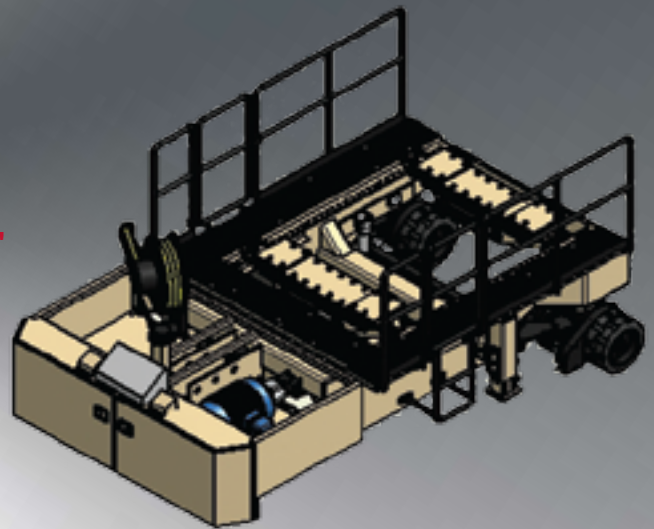
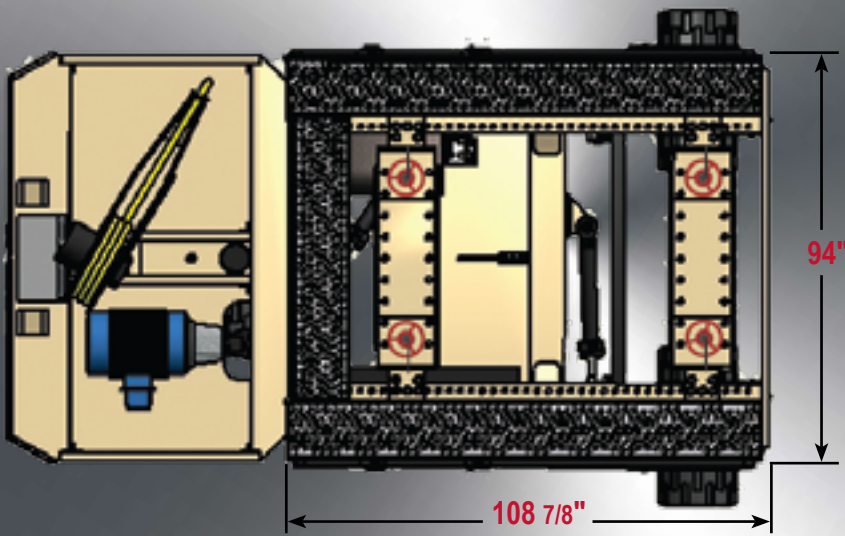

AC MULTI HANDLER TECH SPECS

Visit our web site: www.bdmfg.com

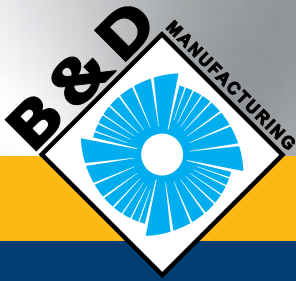

Helping industry succeed with every turn.



- All dimensions are approximate
- Approximate gross weight: **30,000 lbs.**

DC MULTI HANDLER TECH SPECS

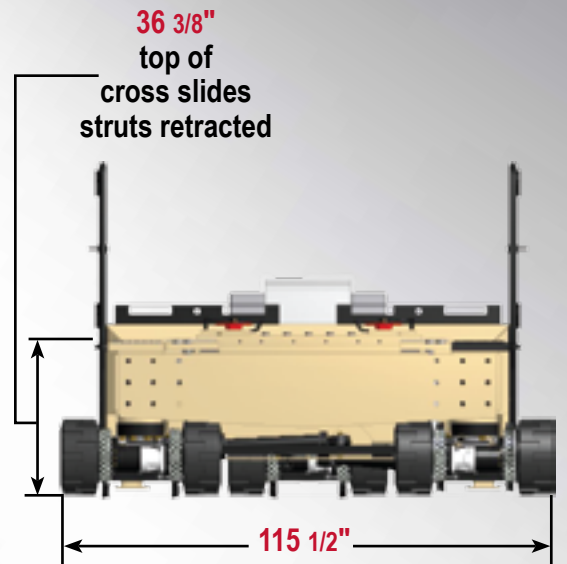
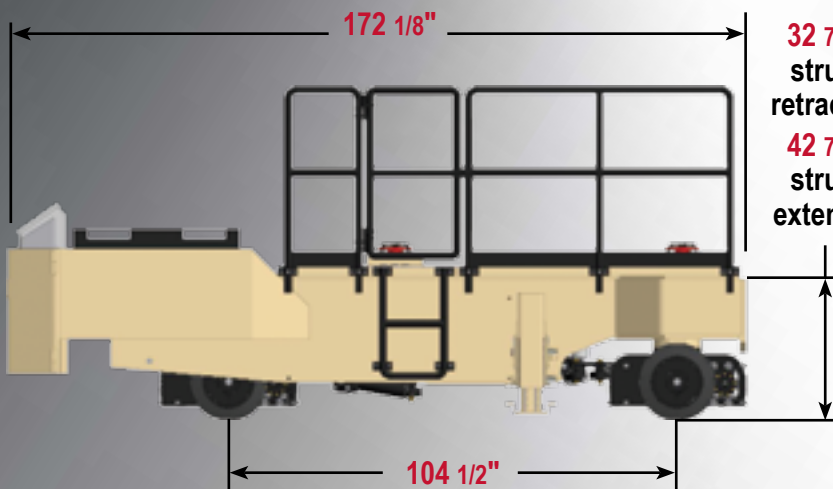
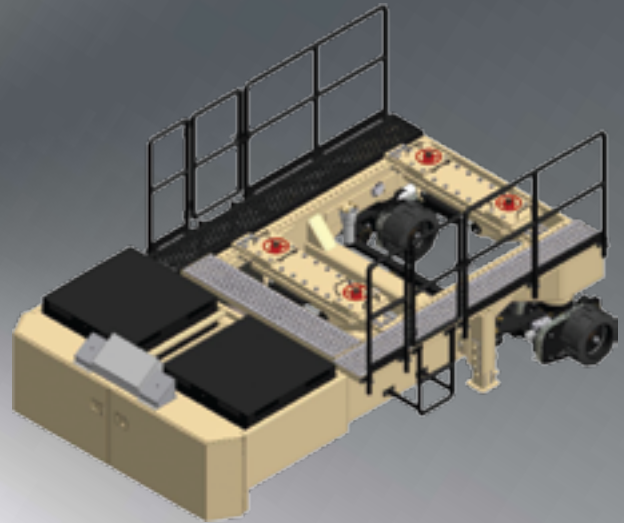
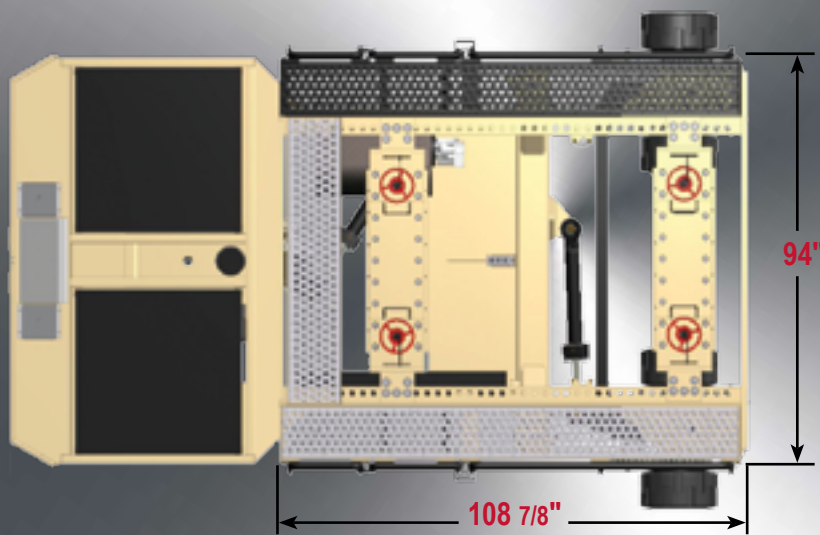

Visit our web site: www.bdmfg.com



1-800-668-0324
Outside Canada and the US: 1-705-855-2363

Multi Handler

Control system

- Parker IQAN control system platform operating at 12Vdc. The IQAN Master communicates with its expansion modules via a CAN-bus protocol.
- Includes a custom designed Radio Remote Control Terminal and Base Unit for complete control of the vehicle's functions. The Base Unit communicates with the IQAN Master over CAN-bus via a J1939 communications protocol.
- Includes an RPM Dual Speed Switch for signaling of rpm high rotation warning and shutdown speeds to the IQAN Master.
- Includes a Keyswitch and Emergency Stop Push Button that allows the end-user to power up/power down the vehicle's control system.

Hydraulic power source

- closed center, load sense piston pump
- 25 US gallon hydraulic reservoir
- 17 GPM
- 2500 PSI
- 5 micron absolute pressure and return filtration

Diesel Multi Handler

Diesel motor

- YANMAR 3 cylinder diesel engine
- 25 HP at 2000 RPM
- Tier 4 emission standards

AC Multi Handler

Electrical system

- Three phase 30 horsepower AC Motor and Motor Soft Starter.

- Includes a Spring Driven Cable Reel with a Cable Guide Arm and approximately 100 feet of cable.
- Includes a Main Fused Disconnect Switch.
- Includes a Control Transformer and 120Vac to 12Vdc converter that supplies power to the embedded control system.
- The electrical system requires a 480/575Vac 50amp 60hertz 3 wire plus ground power supply. The power supply requirements for this vehicle can be tailored to meet the end-user's needs.

DC Multi Handler

Electrical system

- DC Series Wound Motor and DC Motor Controller powered by a 96Vdc power supply.
- 96Vdc power is supplied from two (2) 48Vdc 1020 amp-hour rated Industrial Battery Packs that have been connected in series.
- The Industrial Battery Packs have a single point water system incorporated in their design.
- Includes a Master Disconnect Switch and a Heavy Duty DC Disconnect Emergency Stop.
- Includes an RPM Speed Sensor and Tachometer to monitor the operating rpm output of the DC Series Wound Motor.
- Includes a Battery Controller to monitor the remaining electrical charge on the Industrial Battery Packs.
- Includes a 96Vdc to 12Vdc converter that supplies power to the embedded control system.
- Includes two (2) Industrial Battery Chargers, one per Industrial Battery Pack. Each of the Industrial Battery Chargers requires a 480/575Vac, 17/14amp 60hertz 3 wire plus ground power supply. The power supply requirements for the Industrial Battery Chargers can be tailored to meet the end-user's needs.

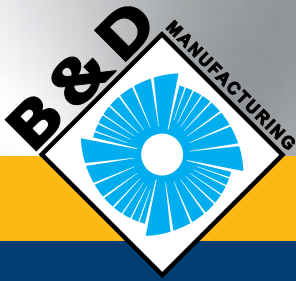

Helping industry succeed with every turn.



WMHA-PB-2.5 / WMHA-PB-4
2.5 Ton Pedestal Boom
4 Ton Pedestal Boom

- Approximate gross weight: **20,100 lbs.**
- Min. Reach Height (WMH-mounted): **To floor**
- Max. Reach Height (WMH-mounted): **11' from floor**

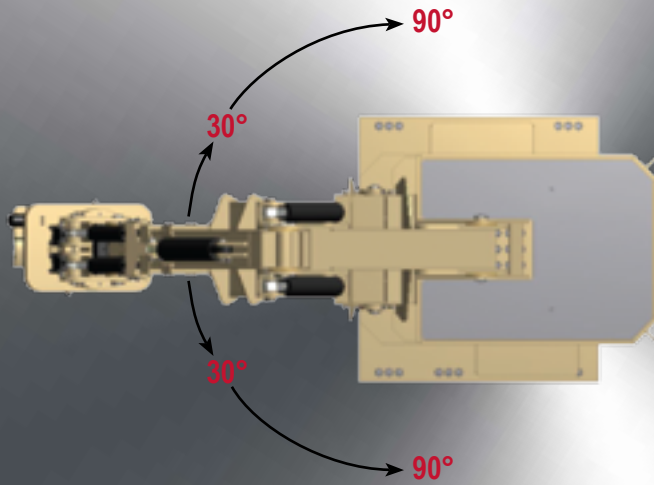

30° rotation for 4 ton Pedestal Boom
90° rotation for 2.5 ton Pedestal Boom

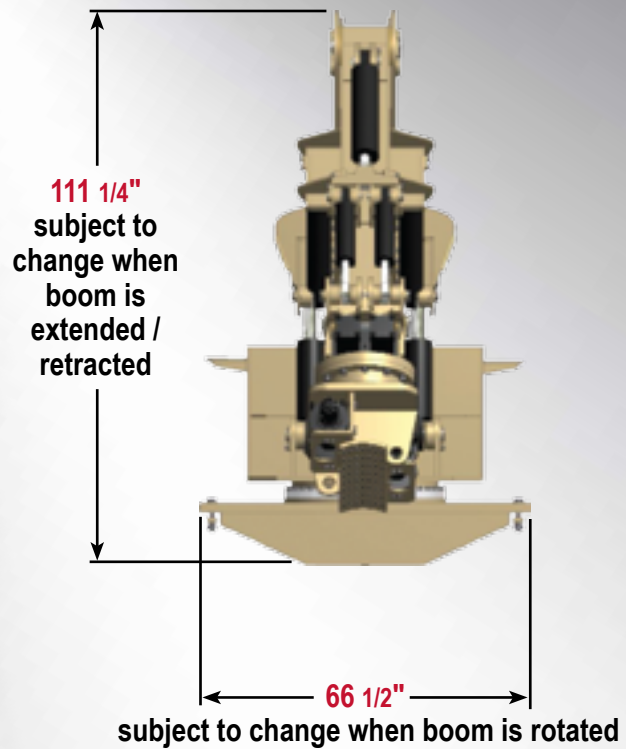
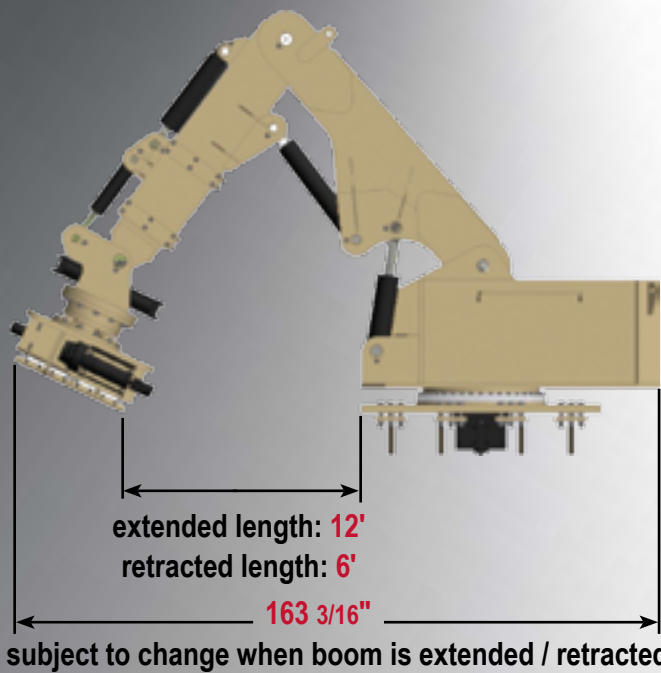
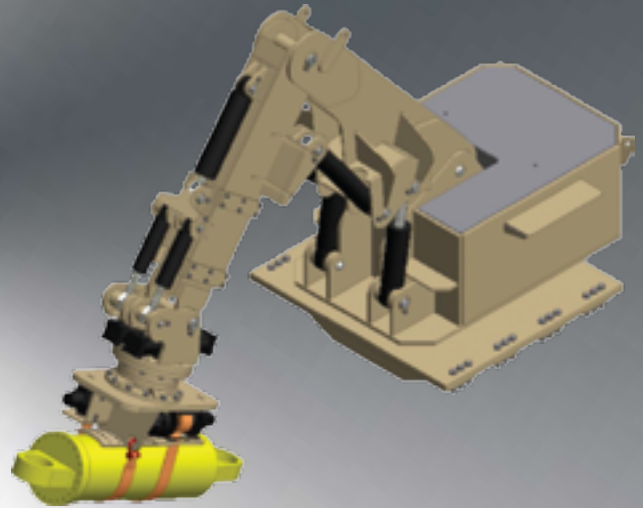

MULTI HANDLER ACCESSORIES

Visit our web site: www.bdmfg.com



1-800-668-0324
Outside Canada and the US: 1-705-855-2363



Pedestal Boom Removing Main Dump Body Cylinder



Pedestal Boom Removing Rear Strut

MULTI HANDLER ACCESSORIES

Visit our web site: www.bdmfg.com

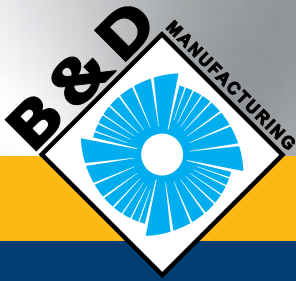

Helping industry succeed with every turn.



WMHA-SHBRT
Spindle Hub Brake Removal Tool

- Approximate weight: **3,456 lbs.**
(excluding 860E Adaptor Ring & 860E Brake)

860E Spindle Hub Brake

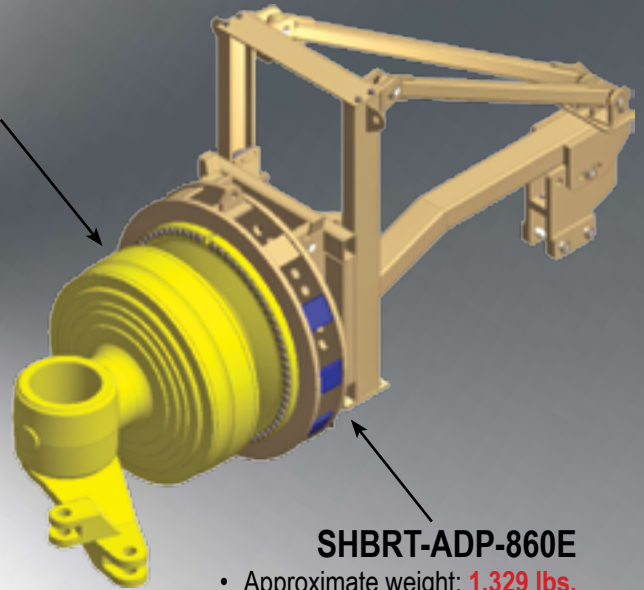
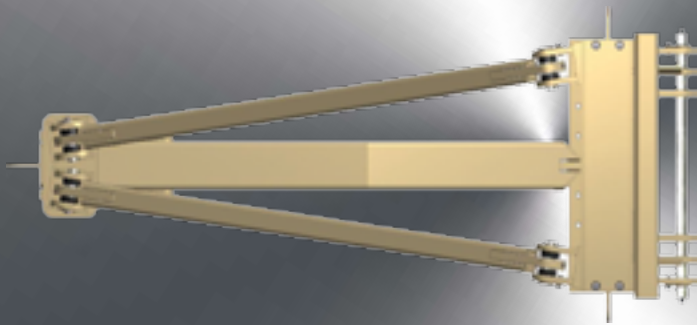

SHBRT-ADP-860E

- Approximate weight: **1,329 lbs.**
- Approximate size: **61 1/2" W x 66 3/8" H x 16" D**

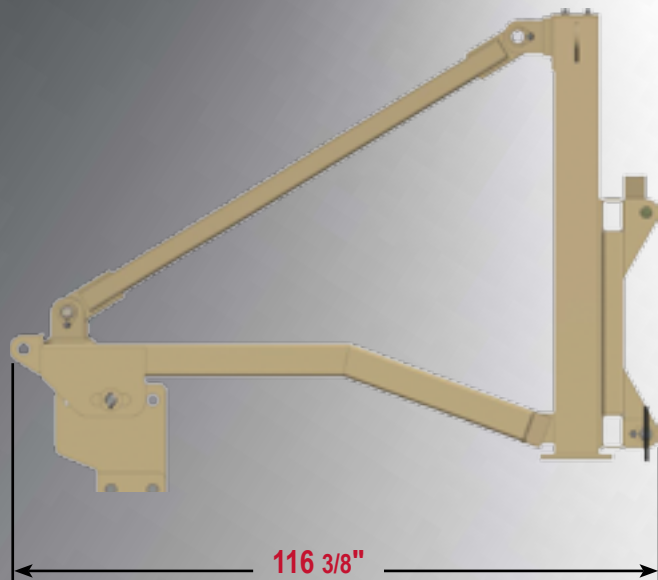

116 3/8"

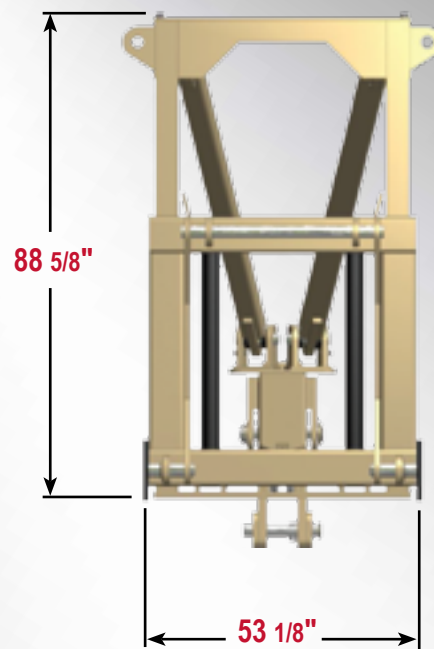

88 5/8"

53 1/8"

MULTI HANDLER ACCESSORIES

Visit our web site: www.bdmfg.com



1-800-668-0324
Outside Canada and the US: 1-705-855-2363

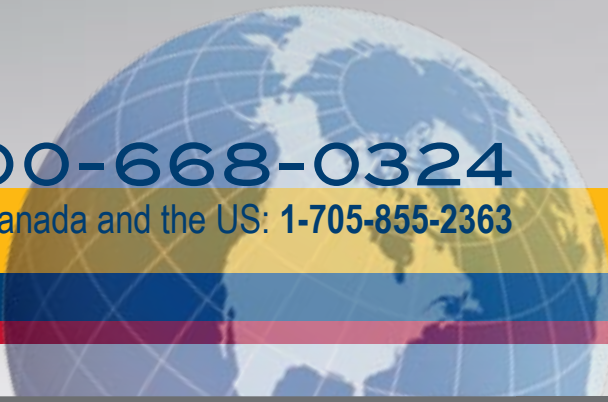

SHBRT-ADP Spindle Hub Brake Removal Tool Adaptors

• Approximate size: 61 1/2" W x 66 3/8" H x 16" D

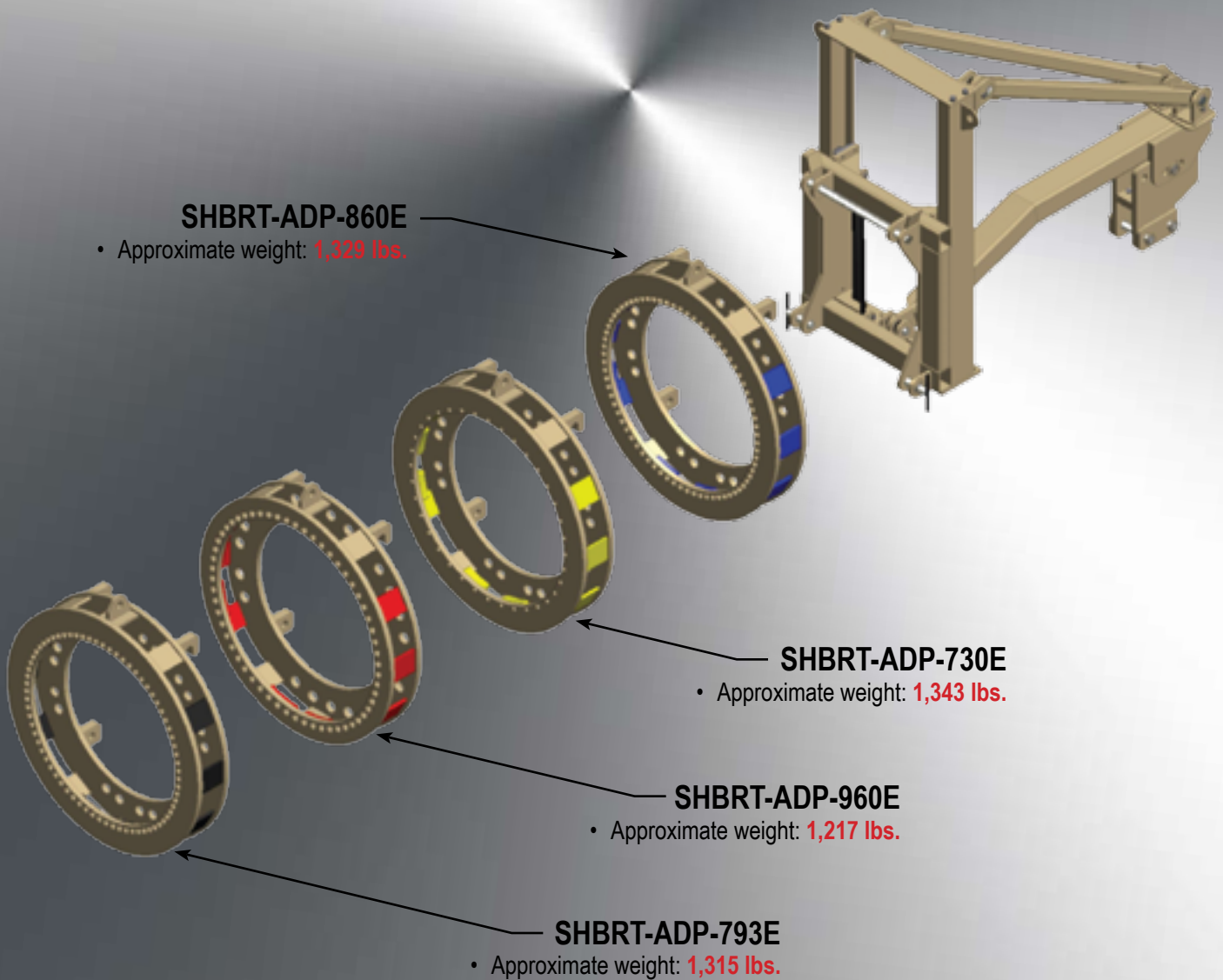

SHBRT-ADP-860E
• Approximate weight: 1,329 lbs.

SHBRT-ADP-730E
• Approximate weight: 1,343 lbs.

SHBRT-ADP-960E
• Approximate weight: 1,217 lbs.

SHBRT-ADP-793E
• Approximate weight: 1,315 lbs.

Additional custom designed adaptor rings are available for your fleet upon request.

MULTI HANDLER ACCESSORIES

Visit our web site: www.bdmfg.com

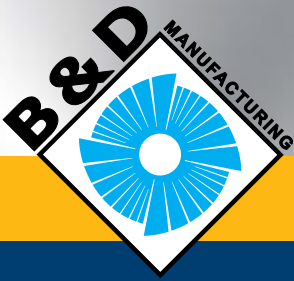

Helping industry succeed with every turn.



WMHA-FSRT-U
Universal Front Strut Removal Tool

- Approximate gross weight: **5,800 lbs.**
(excluding 797B Adaptor Ring & 797B Strut)

797B Front Strut →

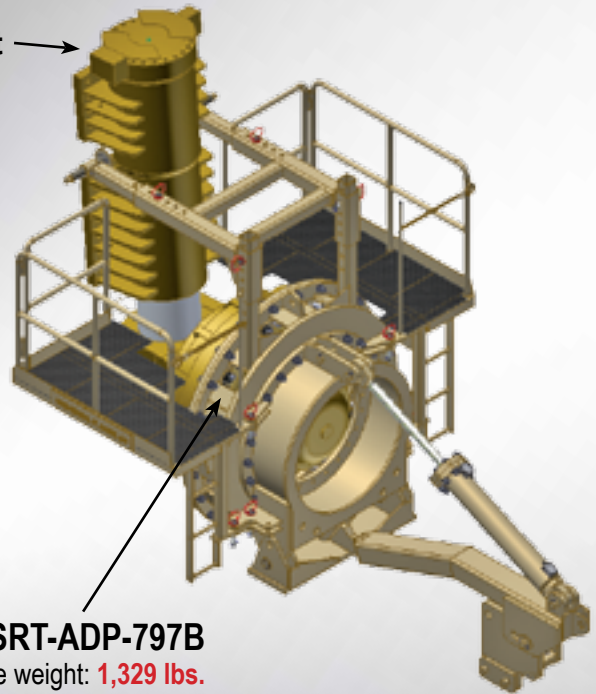
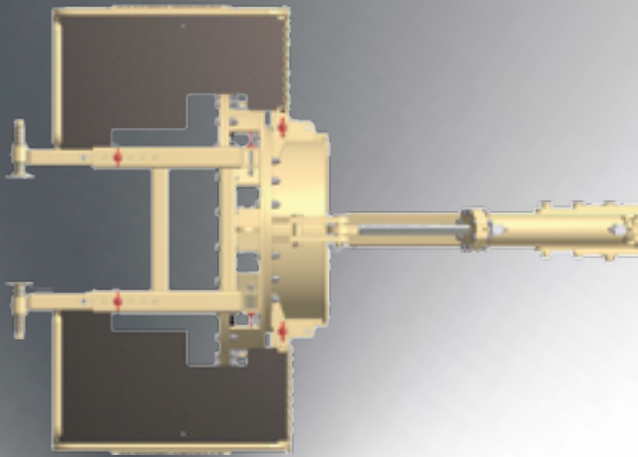

FSRT-ADP-797B

- Approximate weight: **1,329 lbs.**
- Approximate size: **61 1/2" W x 66 3/8" H x 16" D**

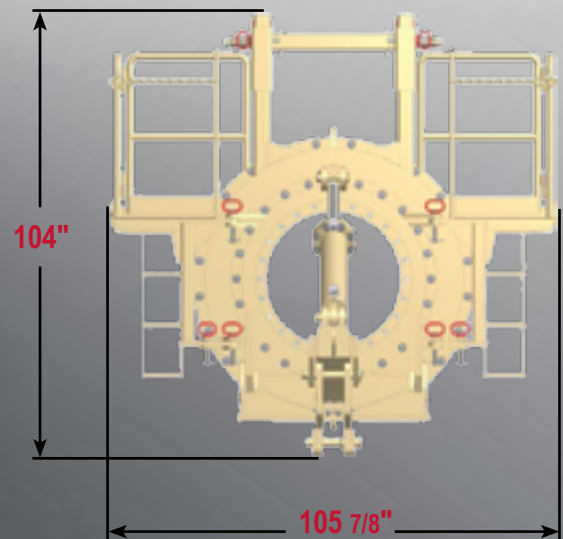
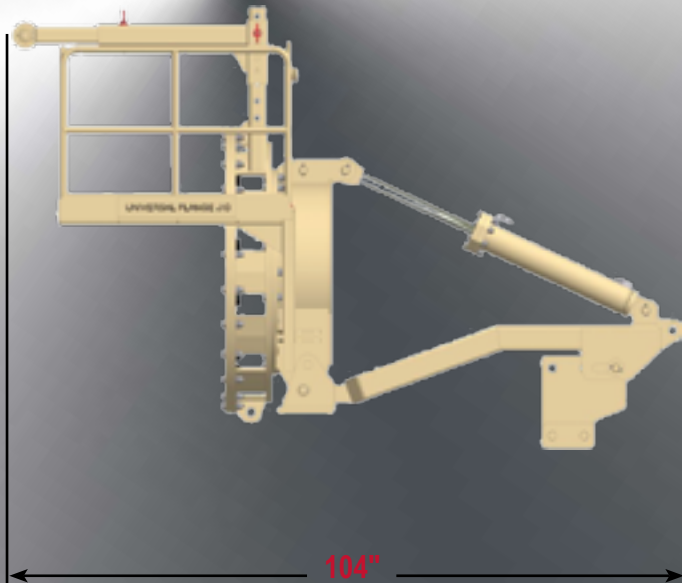

Additional custom designed adaptor rings are available for your fleet upon request.

MULTI HANDLER ACCESSORIES



1-800-668-0324
Outside Canada and the US: 1-705-855-2363

WMHA-FSRT-797B-ECONO
Caterpillar 797B Front Strut Removal Tool

- Approximate gross weight: **1,972 lbs.**
(excluding 797B Strut)

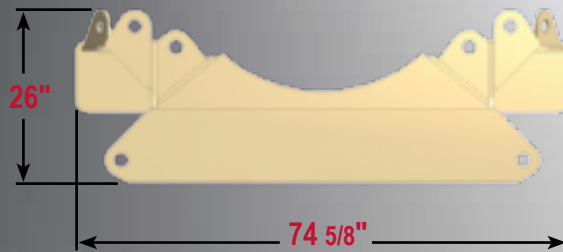
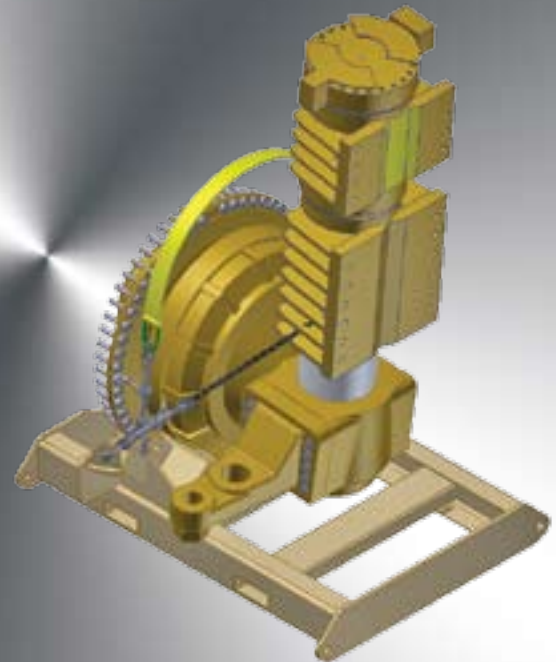
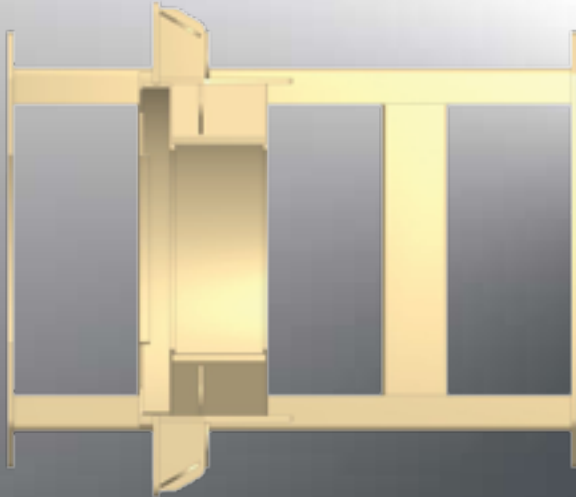

MULTI HANDLER ACCESSORIES

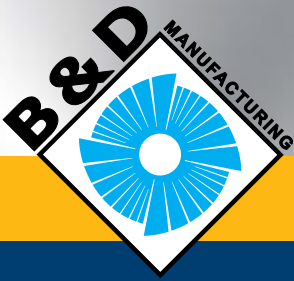

Helping industry succeed with every turn.



WMHA-FSRT-830E-ECONO
Komatsu 830E Front Strut Removal Tool

- Approximate gross weight: **1,457 lbs.**
(excluding 830E Strut)

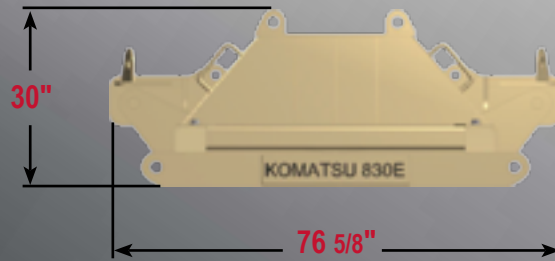
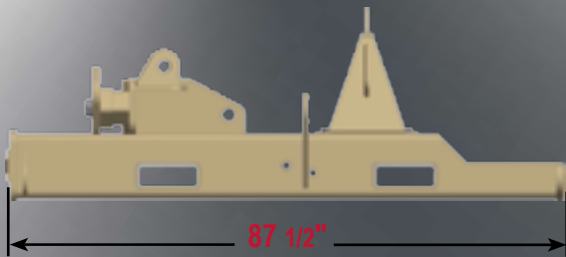
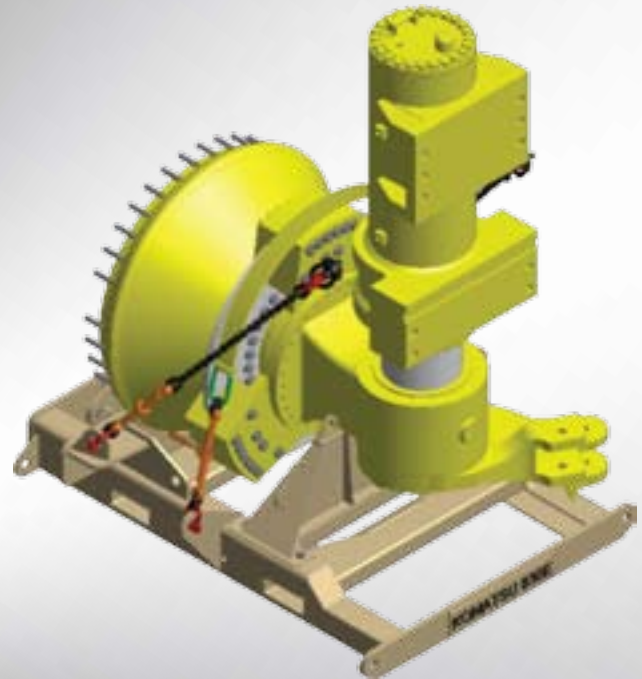
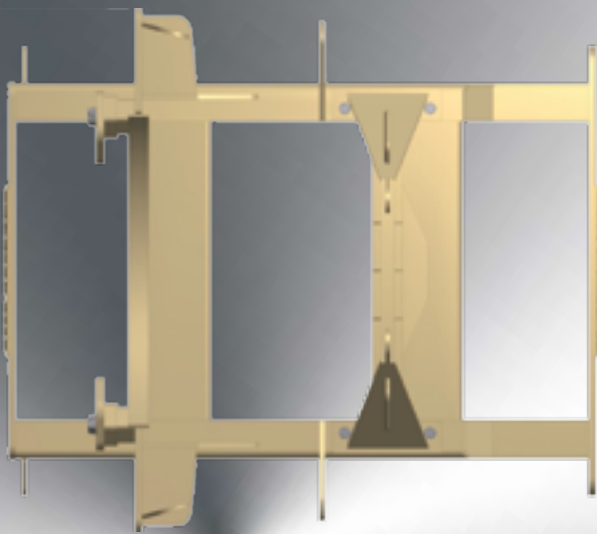

MULTI HANDLER ACCESSORIES



1-800-668-0324
Outside Canada and the US: 1-705-855-2363

WMHA-FSRT-930E-ECONO
Komatsu 930E Front Strut Removal Tool

- Approximate gross weight: **1,730 lbs.**
(excluding 930E Strut)

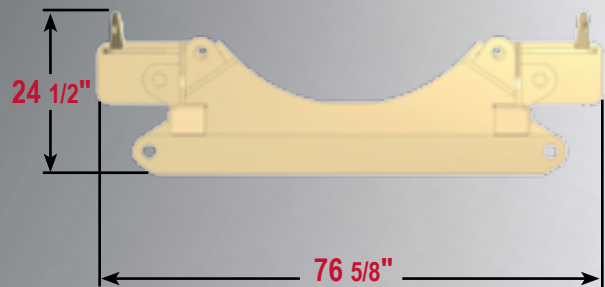
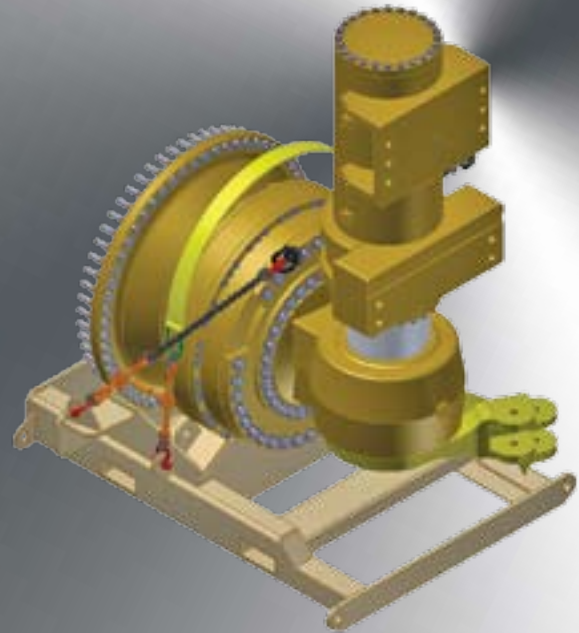
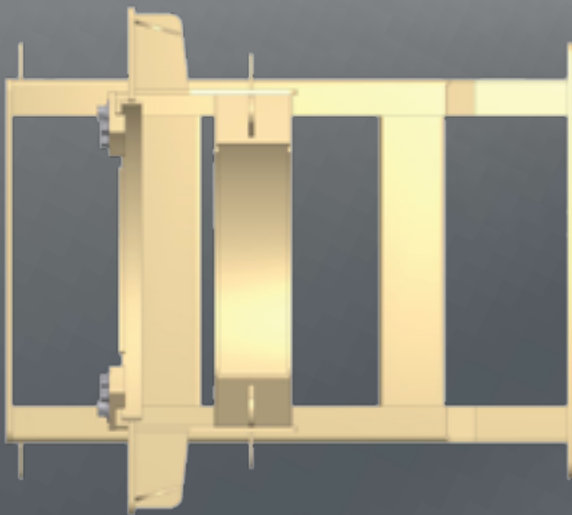

MULTI HANDLER ACCESSORIES

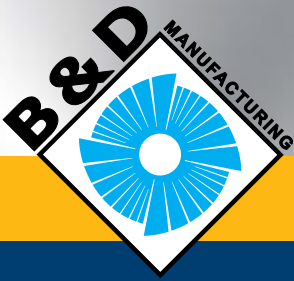

Helping industry succeed with every turn.



WMHA-RWG-793
Caterpillar 793 Rear Wheel Group Removal Tool

- Approximate gross weight: **2,130 lbs.**
(excluding 793 RWG)

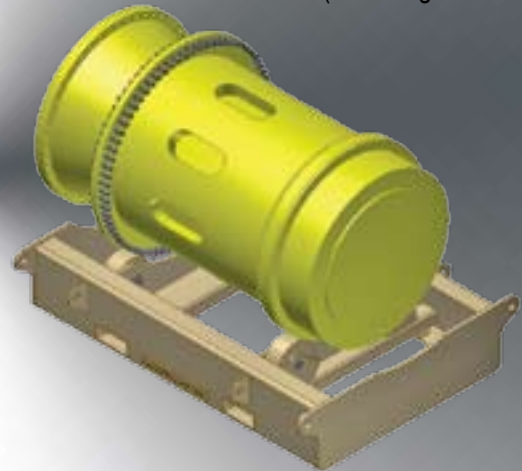
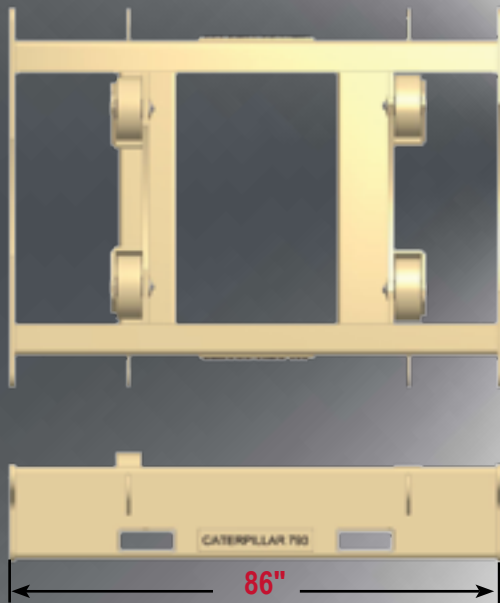

WMHA-RWG-797B
Caterpillar 797B Rear Wheel Group Removal Tool

- Approximate gross weight: **1,607 lbs.**
(excluding 797B RWG)

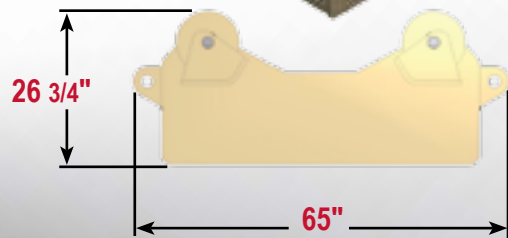
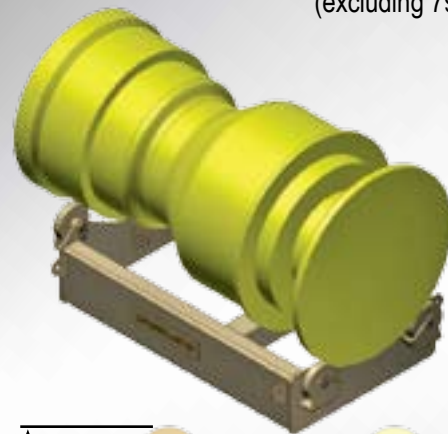

MULTI HANDLER ACCESSORIES

Visit our web site: www.bdmfg.com



1-800-668-0324
 Outside Canada and the US: 1-705-855-2363



WMHA-RWG-730E
Komatsu 730E Rear Wheel Group Removal Tool

- Approximate gross weight: **2,102 lbs.**
 (excluding 730E RWG)

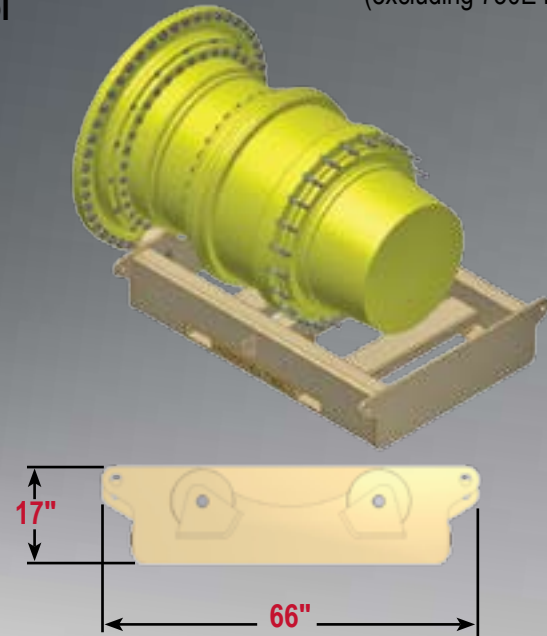
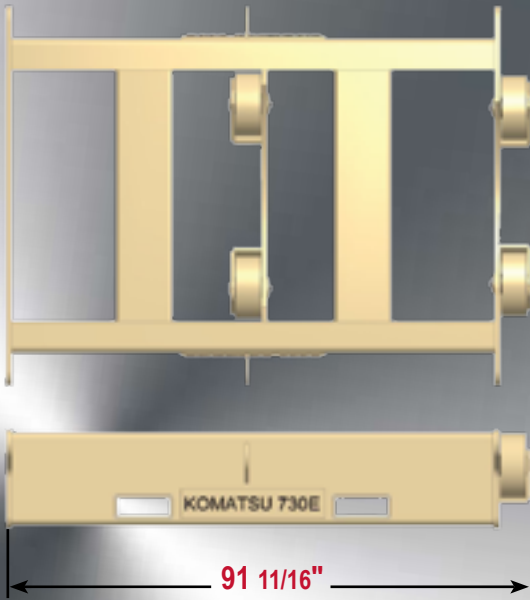

WMHA-RWG-830E
Komatsu 830E Rear Wheel Group Removal Tool

- Approximate gross weight: **1,739 lbs.**
 (excluding 830E RWG)

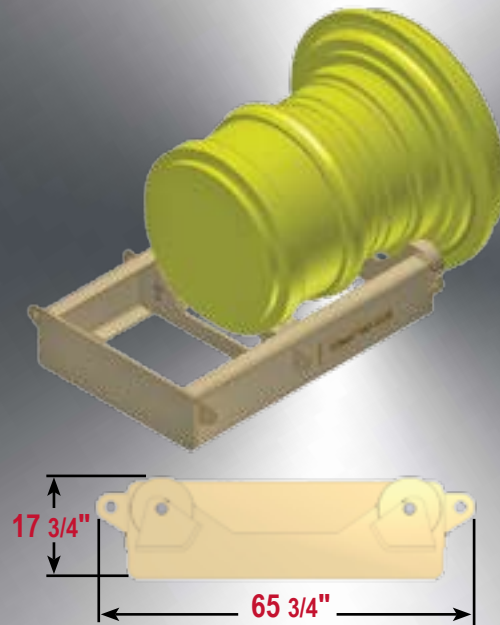

MULTI HANDLER ACCESSORIES

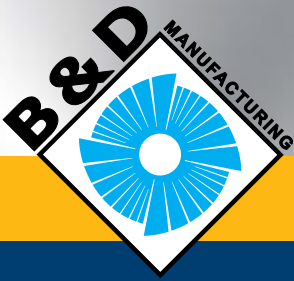

Helping industry succeed with every turn.



WMHA-RWG-860E
Komatsu 860E Rear Wheel Group Removal Tool

- Approximate gross weight: **2,132 lbs.**
(excluding 860E RWG)

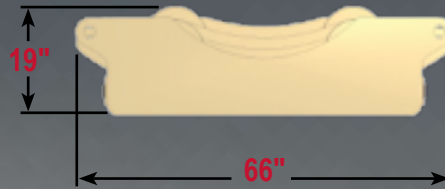
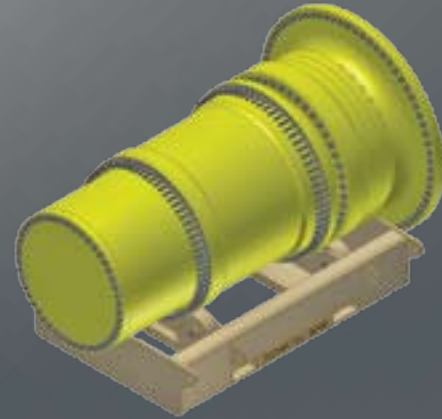
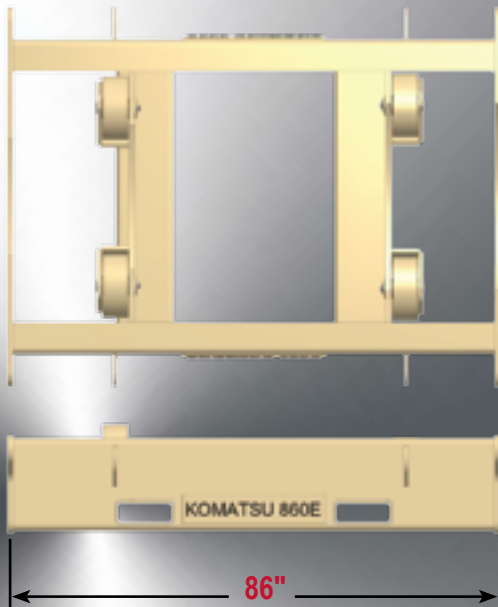

WMHA-RWG-930E
Komatsu 930E Rear Wheel Group Removal Tool

- Approximate gross weight: **2,102 lbs.**
(excluding 930E RWG)

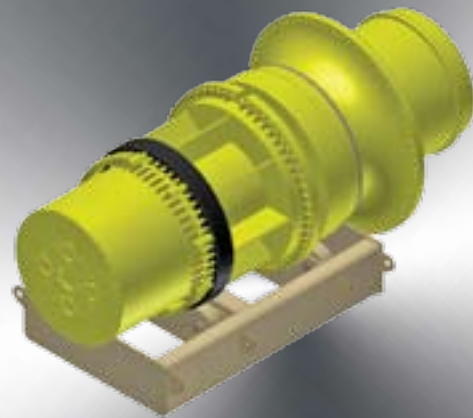

MULTI HANDLER ACCESSORIES

Visit our web site: www.bdmfg.com



1-800-668-0324
Outside Canada and the US: 1-705-855-2363



WMHA-RWG-960E
Komatsu 960E Rear Wheel Group Removal Tool

- Approximate gross weight: **1,981 lbs.**
(excluding 960E RWG)

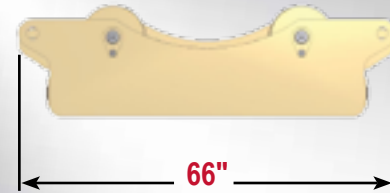
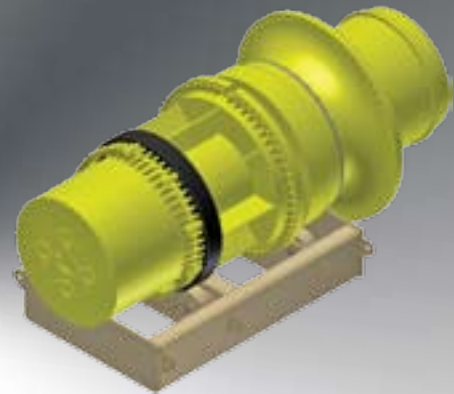
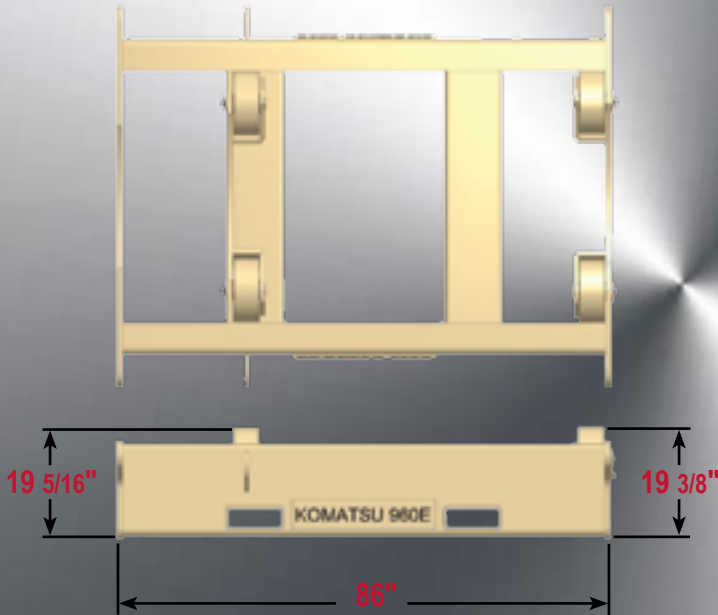

WMHA-RWG-T-282
Liebherr Rear Wheel Group Removal Tool

- Approximate gross weight: **971 lbs.**

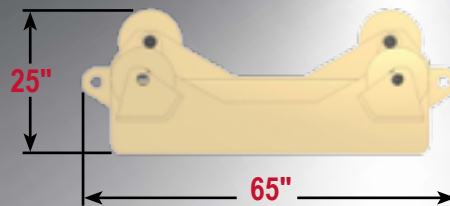
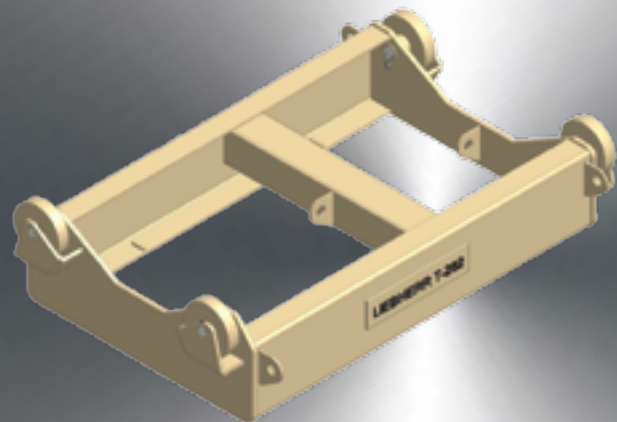

MULTI HANDLER ACCESSORIES

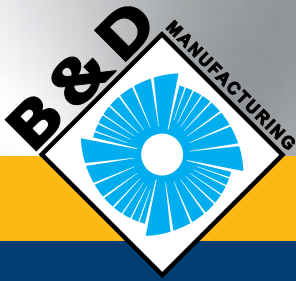

Helping industry succeed with every turn.



WMHA-RDRT-797B
Rear Differential Removal Tool

- Approximate gross weight: **2,974 lbs.**
(excluding 797B Trans Axle & stands)

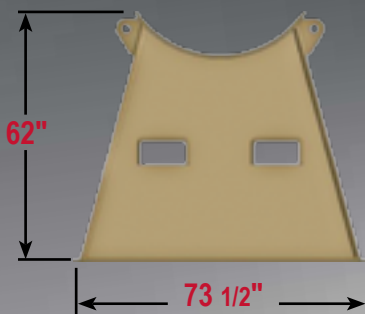
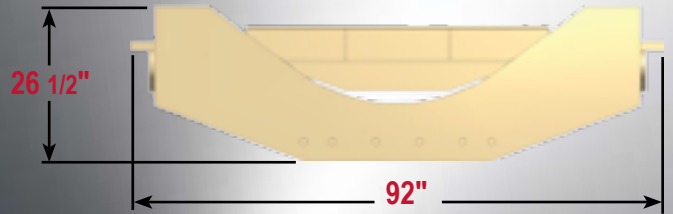
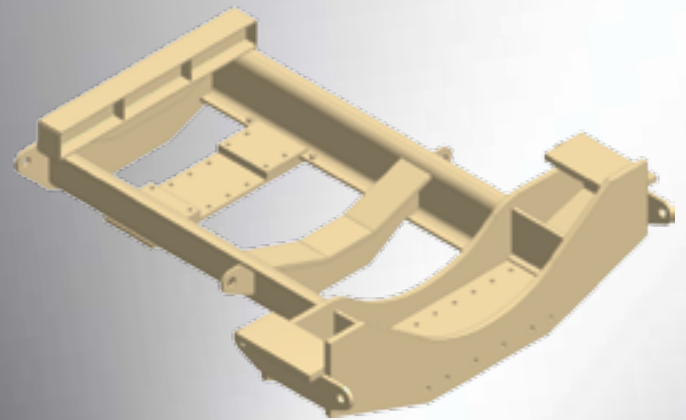
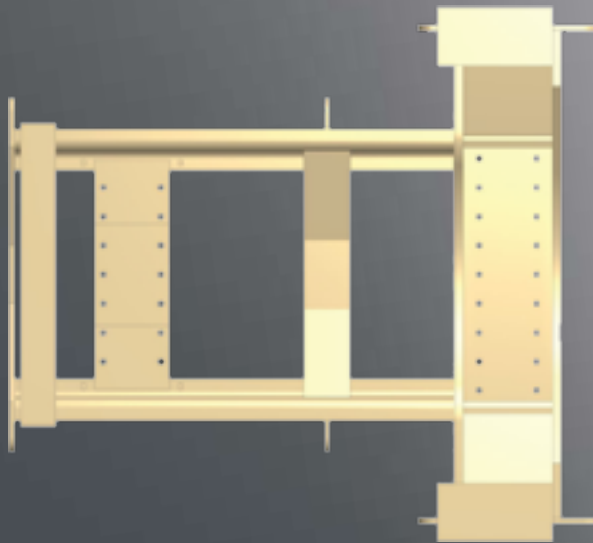

RDRT-797B-STAND

- Approximate weight: **3,221 lbs.**

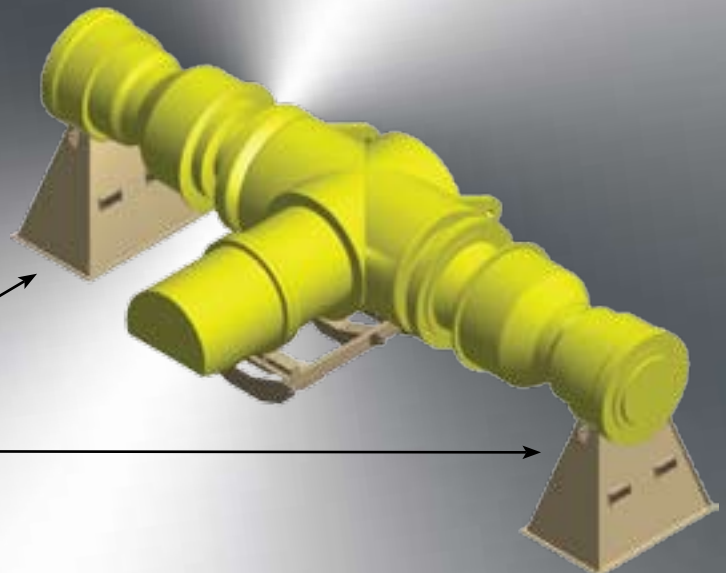

MULTI HANDLER ACCESSORIES

Visit our web site: www.bdmfg.com



1-800-668-0324
Outside Canada and the US: 1-705-855-2363

SB-WMH-3W
Multi Handler Spreader Bar

- Approximate gross weight: **2,800 lbs.**

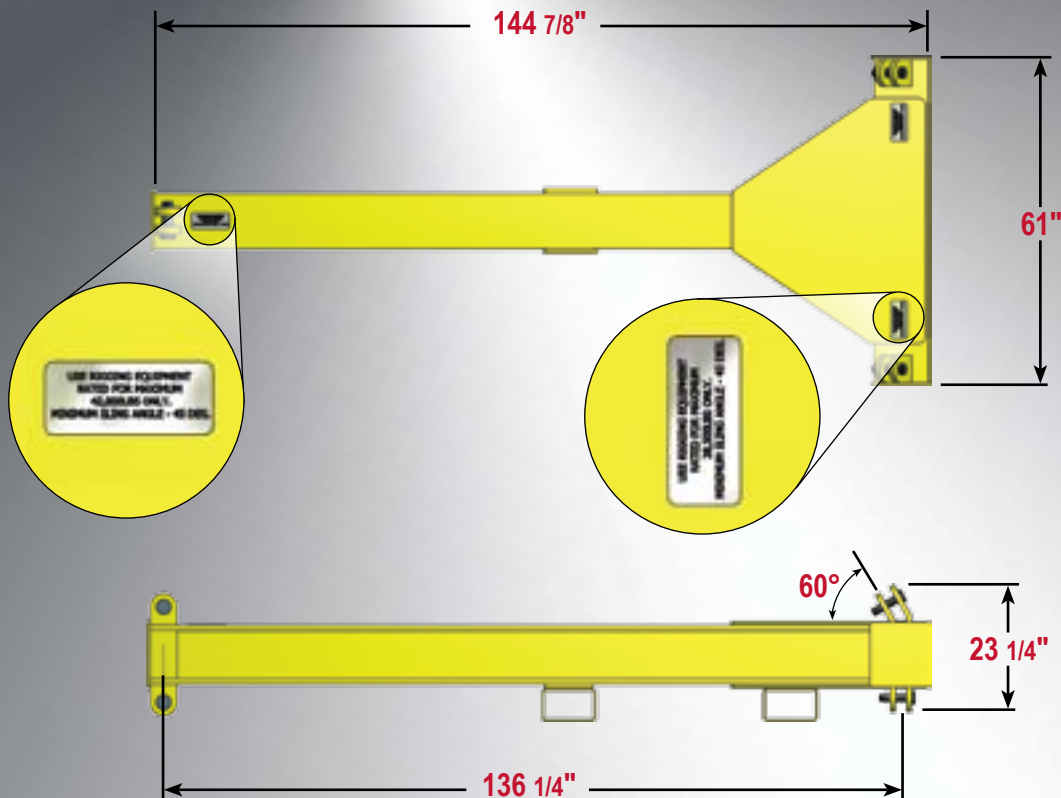
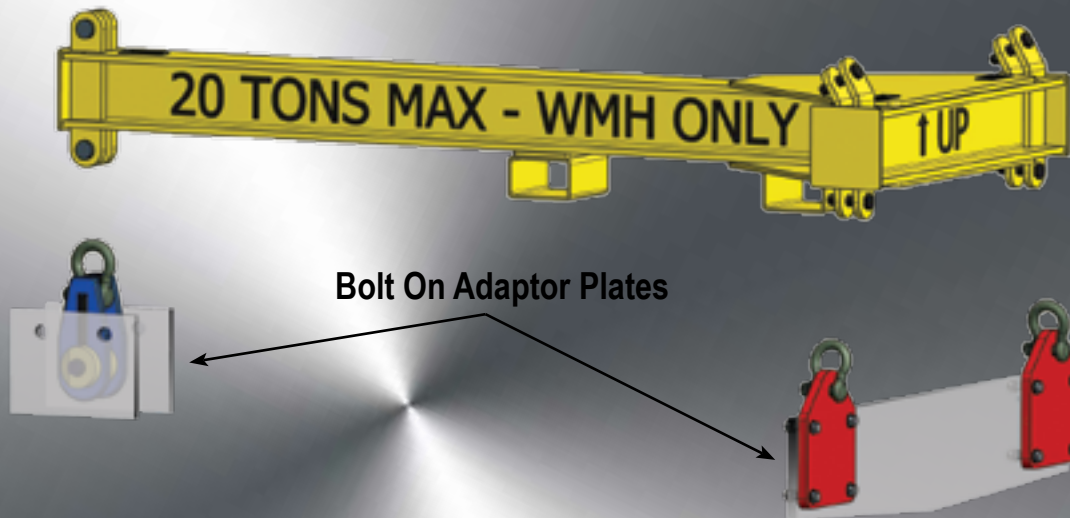

MULTI HANDLER ACCESSORIES



Your local distributor:



Founded in 1980, B&D Manufacturing is a dynamic Canadian company that designs, manufactures and distributes innovative products and technologies to increase production and improve safety for industries globally. Our line includes products designed to support equipment for mines & mills, open pit trucks and shovels and construction. In addition to our OEM product line, we support a variety of clients with custom design, fabrication and manufacturing, on-site repair and rebuild services.

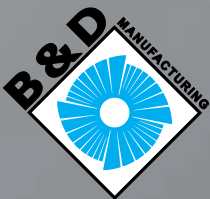

Helping industry succeed with every turn.

Toll-free in the US or Canada:

1-800-668-0324

Other countries phone:

1-705-855-2363

www.bdmfg.com

B&D Manufacturing, Chelmsford, Ontario, Canada