

# Unite UR86 Matrix DSP Amplifier User Guide



**Unite Audio**

**Nexus Audio Video Pty Ltd**

**15-19 Villas Road**

**Dandenong South,**

**Victoria, Australia 3175**

## Table of Contents

Introduction .....	3
Installation .....	3
Equipment .....	3
Amplifier Front-Panel Features .....	3
Amplifier Rear-Panel Features.....	4
Web Interface .....	5
Amplifier Configuration .....	6
Settings .....	8
Amplifier Use .....	14
Specifications .....	15

<b>Document Revision</b>	<b>Details</b>	<b>dd/mm/yy Inits</b>
Rev A	Initial Release.	14/09/21 DV

## Introduction

This document provides a user's guide for the Unite UR86 amplifier. The UR86 is part of the Unite family of Commercial and Domestic amplifiers.

In this guide the term *Zone* refers to a particular location serviced by one of the amplifier outputs. Each Zone may be stereo or Mono. Zones can be single-ended or connected for Bridge-Tied Load (BTL).

The term *Source* refers to a particular signal source connected to the amplifier inputs. Example sources are CD players, solid-state sources such as memory sticks, Internet streaming sources, microphones and so on.

## Installation

The simplest configuration of the UR86 is with stereo (Inputs 1, 2, 3, 4, 5 and 6) analog signal Inputs and stereo Speaker outputs.

An S/PDIF digital audio signal may also be connected to Input 7 and a USB signal to input 8.

## Equipment

- Model UR86 Amplifier
- Loudspeakers
- Signal sources
- Internet connection
- Web browser (Chrome, Firefox, Edge, Vivaldi etc.)
- Interconnect cables

## Amplifier Front-Panel Features

The UR86 amplifier indicates its operational condition with three LED indicators on the right-hand side.

### LED indicators

The UR86 LED indicators show the power/boot status, network connection status and alert status.

## Amplifier Rear-Panel Features

All the connectors for the UR86 amplifier are on the rear panel. This includes Power, internet, hardware controls, signal Source inputs and Zone speaker outputs.

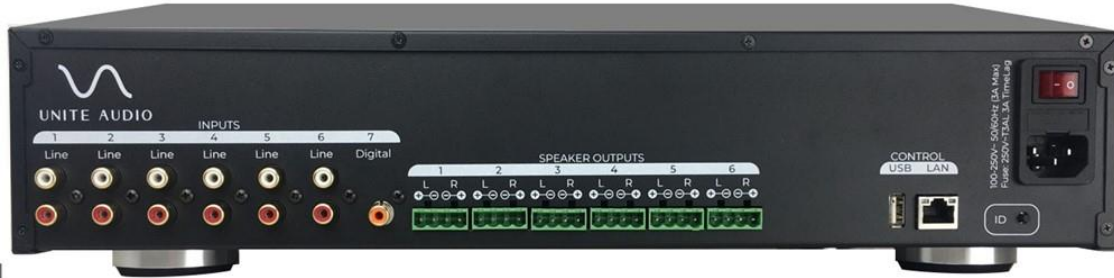

### Basic Connections

Make sure the amplifier mains switch is in the Off (O) position before making any connections.

- Connect mains power to the mains input socket.
- Connect Source signal sources to the Inputs as required.
- Connect Zone speakers to the Speaker Outputs as required.
- Connect the amplifier to the internet via a patch cable to the LAN socket.

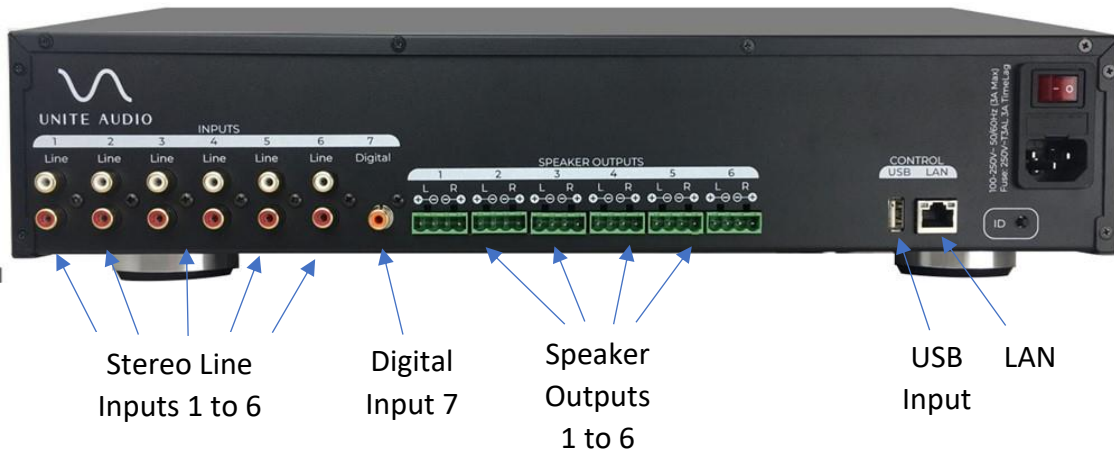

### Power-up

Check connections and move the power switch to the ON (I) position.

The front panel power LED will flash while the amplifier boots up, acquires an IP address and loads its last-set configuration.

When this process has completed the power LED will remain ON steady and the network LED will remain on if a network connection is attained.

## Web Interface

The UR86 amplifier can be configured and controlled via its web interface.

There are 2 levels of access: User and Manager. Manager access is required for Configuration and Control while User only allows Zone volume control.

### Login

Enter the following address into your Web browser (most browsers):

<http://unite.local>

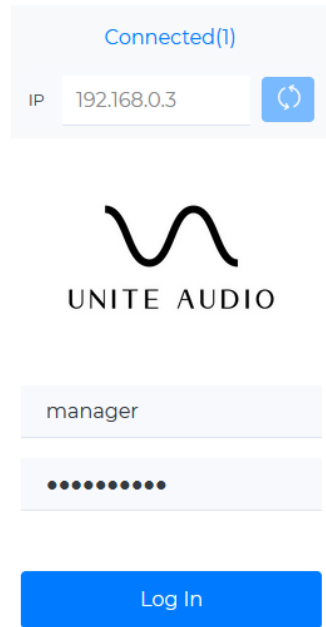

The screenshot shows the web interface of the Unite Audio amplifier. At the top, it displays "Connected(!)" in blue text. Below this, there is a text input field containing the IP address "192.168.0.3" and a blue circular refresh button to its right. In the center, there is a black wavy line logo above the text "UNITE AUDIO". Below the logo, there are two text input fields: the first contains the username "manager" and the second contains a password represented by ten black dots. At the bottom, there is a prominent blue button with the text "Log In" in white.

In this case the amplifier's IP address is *192.168.0.3*. (Individual address ranges will vary.)

For basic User access enter the word *"user"* for the user and *"uunite2020"* for the password.

For full access enter Manager credentials. Please request this information from your sales contact.

## Amplifier Configuration

The UR86 amplifier needs to be configured via web browser prior to use in a new installation. **Manager credentials are required for this process.** The parameters that need to be set include the following:

Sources:

- Input gain setting (Sources 1 to 7)
- Volume settings - Volume Limit, Volume and Balance
- Equalisation settings – High, HighMid, Mid, LowMid, and Low
- Unite Bass

The amplifier also can also have its Zone type configured and Zones and Sources can be renamed for convenience to suit the physical layout and signal sources.

### Configuration

Upon successful login the amplifier will display its Zone configuration web page as shown in the image example below.

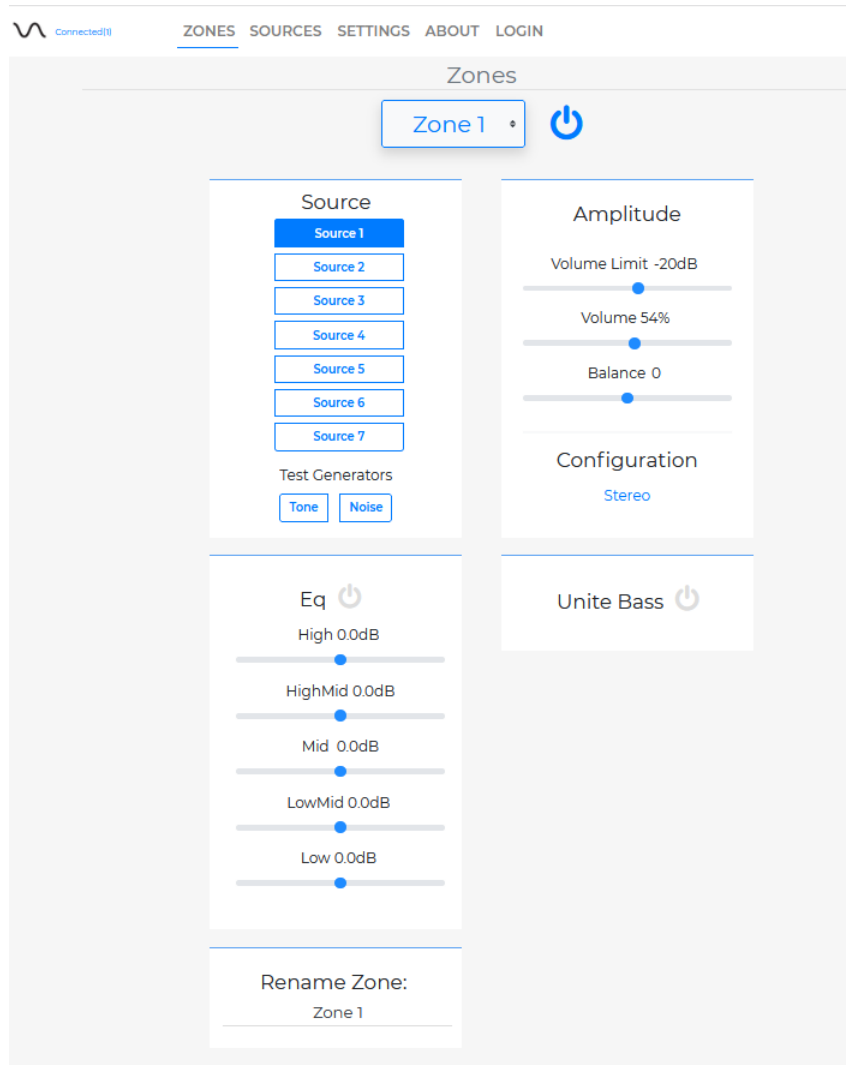

## Unite UR86 Matrix DSP Amplifier User Guide

There is a separate page for each Zone. The individual Zones are selected via the UP/DOWN arrows in the ZONE selection box:

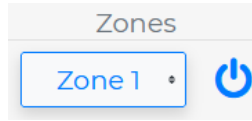

The name of each Zone will be displayed. Note that the Zone names can be changed to suit a particular installation. The defaults are Zone1, Zone2 ... Zone6.

The **ON** icon next to the Zone name **MUST** be **ON** (Blue) for the Zone to be enabled and active. If the Zone is not enabled the **ON** icon will be greyed-out as shown below:

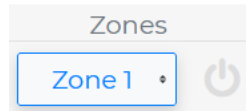

To select a particular Source for a given Zone, select it directly from the SOURCE selection boxes. Note that the Source names can be changed to suit a particular installation. The defaults are Source1, Source2 ... Source7.

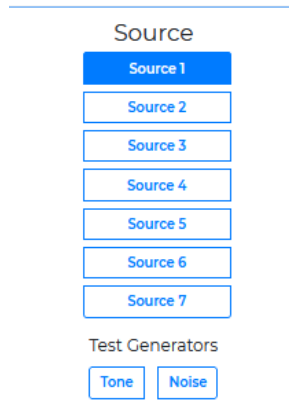

In the example shown above, Source 1 has been selected.

For the selected Source, the Amplitude settings need to be configured. This includes the Volume that is also able to be set via the front panel controls.

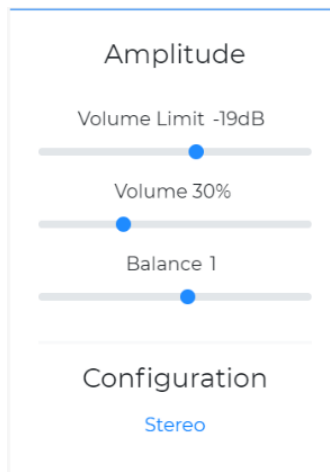

In a similar manner, the Equalisation for the Zone may be configured:



## Settings

The Settings page shows the current Source/Zone crosspoint configuration of the amplifier. This setting is only required if the amplifier zones and speaker setup is changed during installation.

The Connected Device will show the MAC of the target device.



# Unite UR86 Matrix DSP Amplifier User Guide

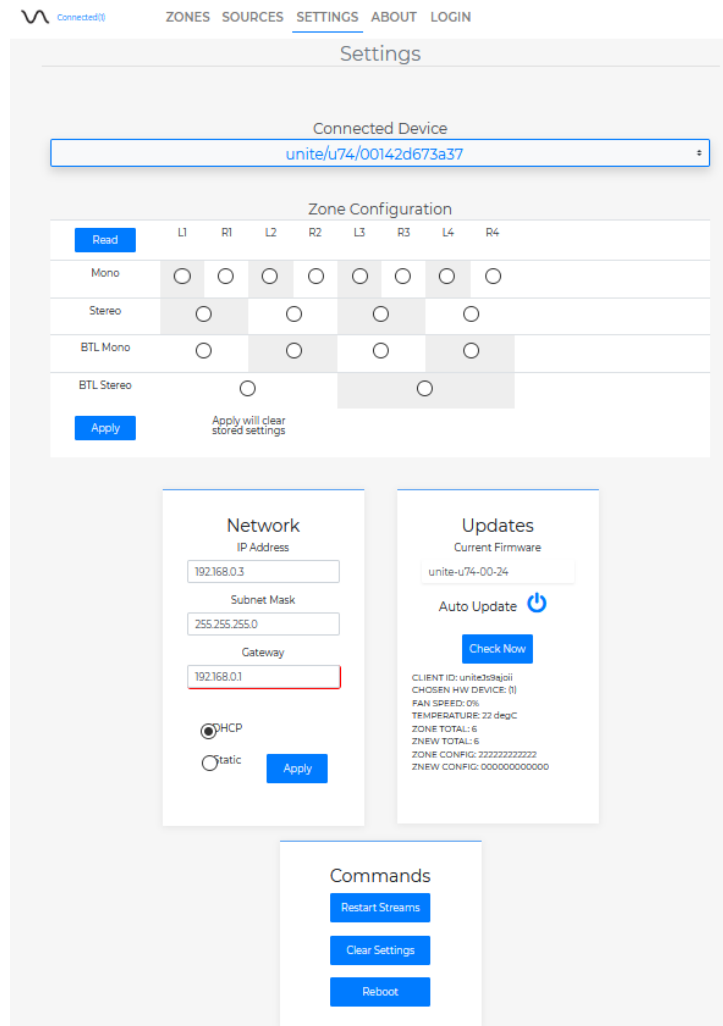

Click the Read button to show the amplifier's current Zone Configuration:

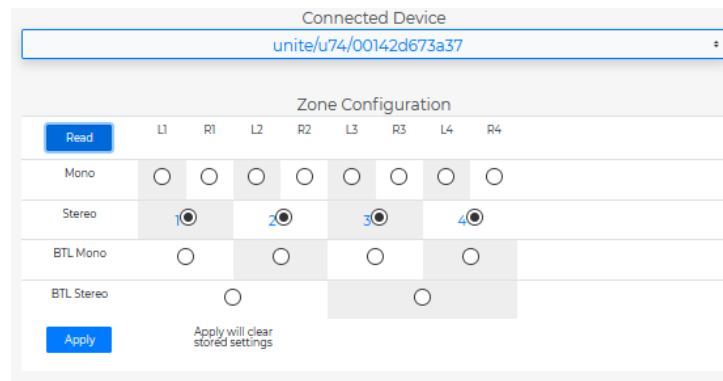

Make any required Zone configuration changes and then click the Apply button to implement these changes and store these settings. The Apply button will only become active for valid configurations.

## Output Configurations

The U74 amplifier can be configured in a variety of mono or stereo Single-Ended or mono or stereo Bridge-Tied-Load formats. It is also possible to mix zone modes.

### **Mono**

In basic mono configuration, each speaker output is an independent mono signal and each connects to a separate speaker.

The zone configuration for this mode is:

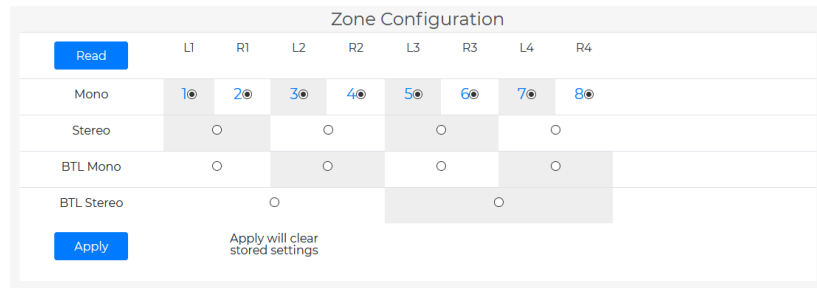

Volume and Tone controls are independent for all 8 zones.

The speaker wiring for this mode is as follows:

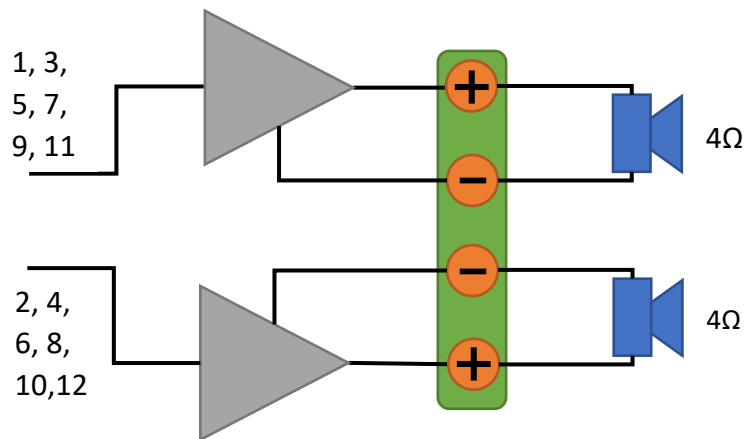

### Stereo

In this configuration Left and Right source signals are treated as a stereo pair and separate Left and Right speakers are used.

The zone configuration for this is:

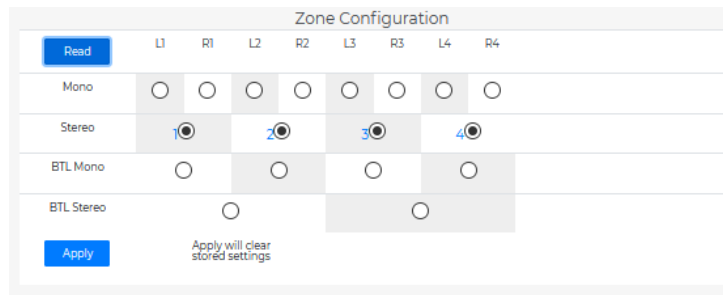

The speaker wiring for this mode is:

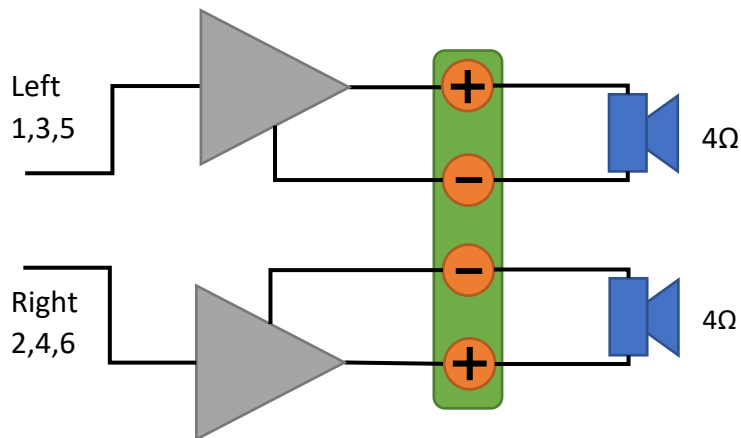

### **Mono BTL**

In this configuration Left and Right source signals are downmixed to mono and a single 8Ω speaker is used.

The zone configuration for this is:

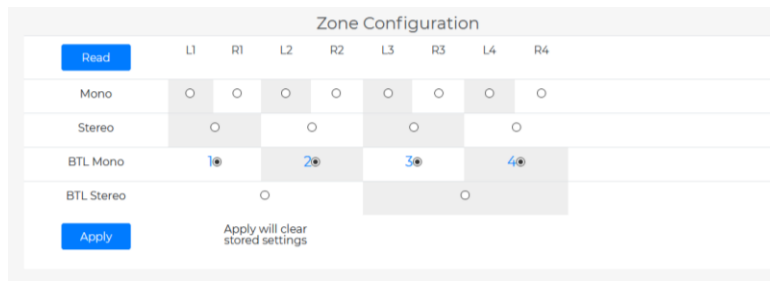

The negative (-) speaker terminals **must** be left unconnected.

The speaker wiring for this mode is as follows:

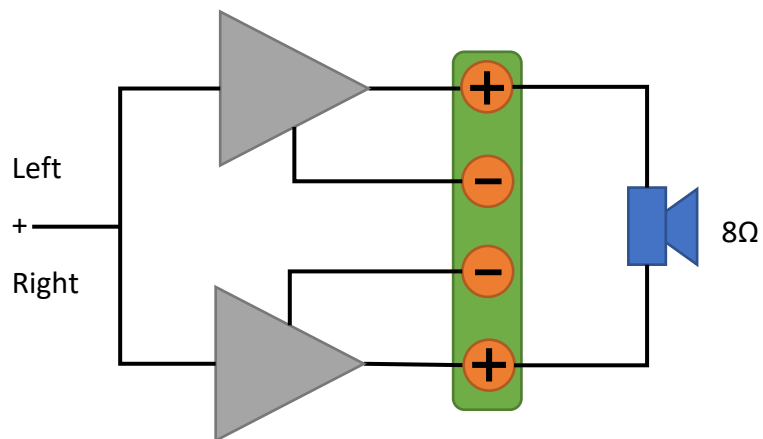

**Stereo BTL**

In this configuration Left and Right source signals are routed as mono BTL signals and single 8Ω speaker are used for each pair.

The zone configuration for this is:

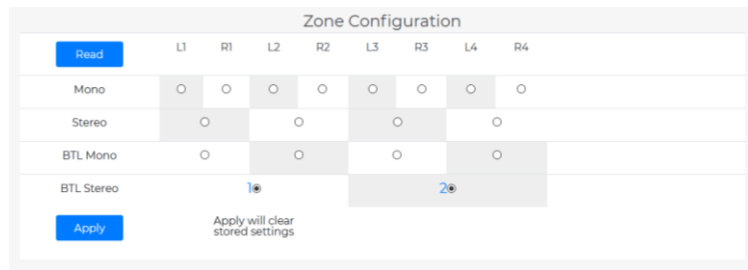

The negative (-) speaker terminals **must** be left unconnected.

The speaker wiring for this mode is as follows:

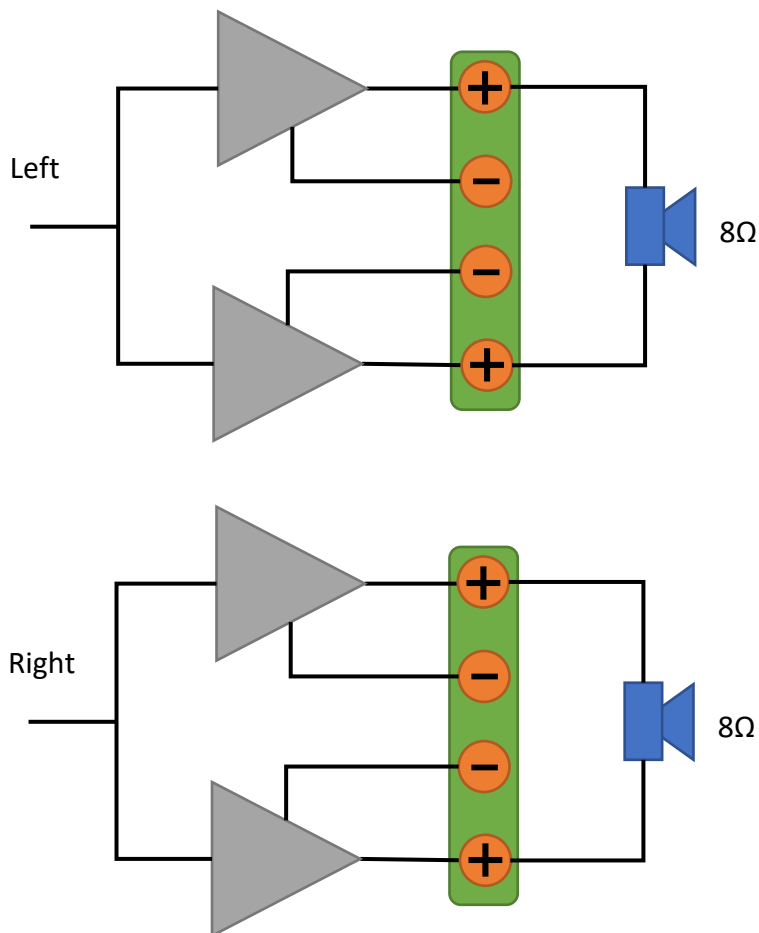

## Amplifier Use

Once configuration is complete, the amplifier may be controlled via web interface in either Manager or User modes and by the front panel controls.

### Web Interface

With User-level access, only the volume, zone enable, and source controls are available:

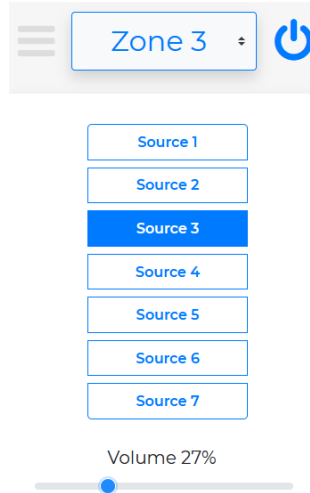

The User cannot change other settings. These settings need to be configured by a Manager.

## Specifications

Unless otherwise specified, Ta=25C, Supplied by U74 @ 230Vac mains voltage.

Mains Supply Voltage	100 to 240Vac
Mains Absolute Minimum/Maximum Supply Voltage	85 to 264Vac
Mains Frequency	45 to 65Hz
Maximum Mains Power Input	400W
Mains Socket	IEC-style
Mains Supply Transients	6kV common mode
Maximum Power Consumption	320W
Standby Power	115Vac: 4.2W 230Vac: 7.8W
Fuse Rating	T3AL Time-Lag 115Vac: 5A 230Vac: 3A
Ambient Temperature	0 to 50C
Maximum Humidity	85% Non-Condensing
Maximum Altitude	2,000m
Cooling	Fan forced, thermostatic control
USB	5Vdc, 0.5A
Output power @ 0.1%THD+N 20Hz < f < 20kHz (single Zone)	RL = 8Ω BTL: 160W RL = 4Ω SE: 80W
Zones	12 x Mono or 6 x Stereo or 6 x BTL Mono or 3 x BTL Stereo
Sources	<ul style="list-style-type: none"> <li>• 6 x Stereo – RCA</li> <li>• 1 x S/PDIF – RCA</li> <li>• 1 x USB</li> </ul>
Dimensions	Stand Alone: 96.5 x 438 x 327.5 (H x W x D) Rack Mount: 87.6 x 481.8 (2RU) x 304 (H x W x D)
Weight	6 kg
Rack Mount	Included

## Unite UR86 Matrix DSP Amplifier User Guide

Status Indication	3 x Status LEDs: <ul style="list-style-type: none"><li>• Power/boot status</li><li>• Network connection status</li><li>• Alert status.</li></ul>
Control	IP