





BUILT ON A LEGACY, FOCUSED ON THE FUTURE



Energy Storage System



Lister Petter Engine Company Limited

E-mail: enquiry@listerpetter.com | Web: www.listerpetter.com |     

Address: Rutland House, Minerva Business Park, Lynch Wood, Peterborough, PE2 6PZ.



Issued in April 2025

NOTES: DESCRIPTIONS AND SPECIFICATION ARE SUBSTANTIALLY CORRECT AT TIME OF PRINTING AND SUBJECT TO CHANGE WITHOUT NOTICE.

APPLICATIONS

Company Background 01

Professional Power Solution Provider

Client End 03

Solar Energy Storage
Energy Storage Power Station

Generation-Side End 07

Generation-Side Energy Storage
Integrated PV Energy Storage Station

Transmission & Distribution 09

Power Station ESS Solutions
Grid Station Area ESS Solutions

Microgrid 11

Solar Energy BESS Charging Station

BESS 14

1 Hour Impact Load Regulation
24 Hours Profile Construction Side



CONTENTS

BESS

Professional Power Solution Provider

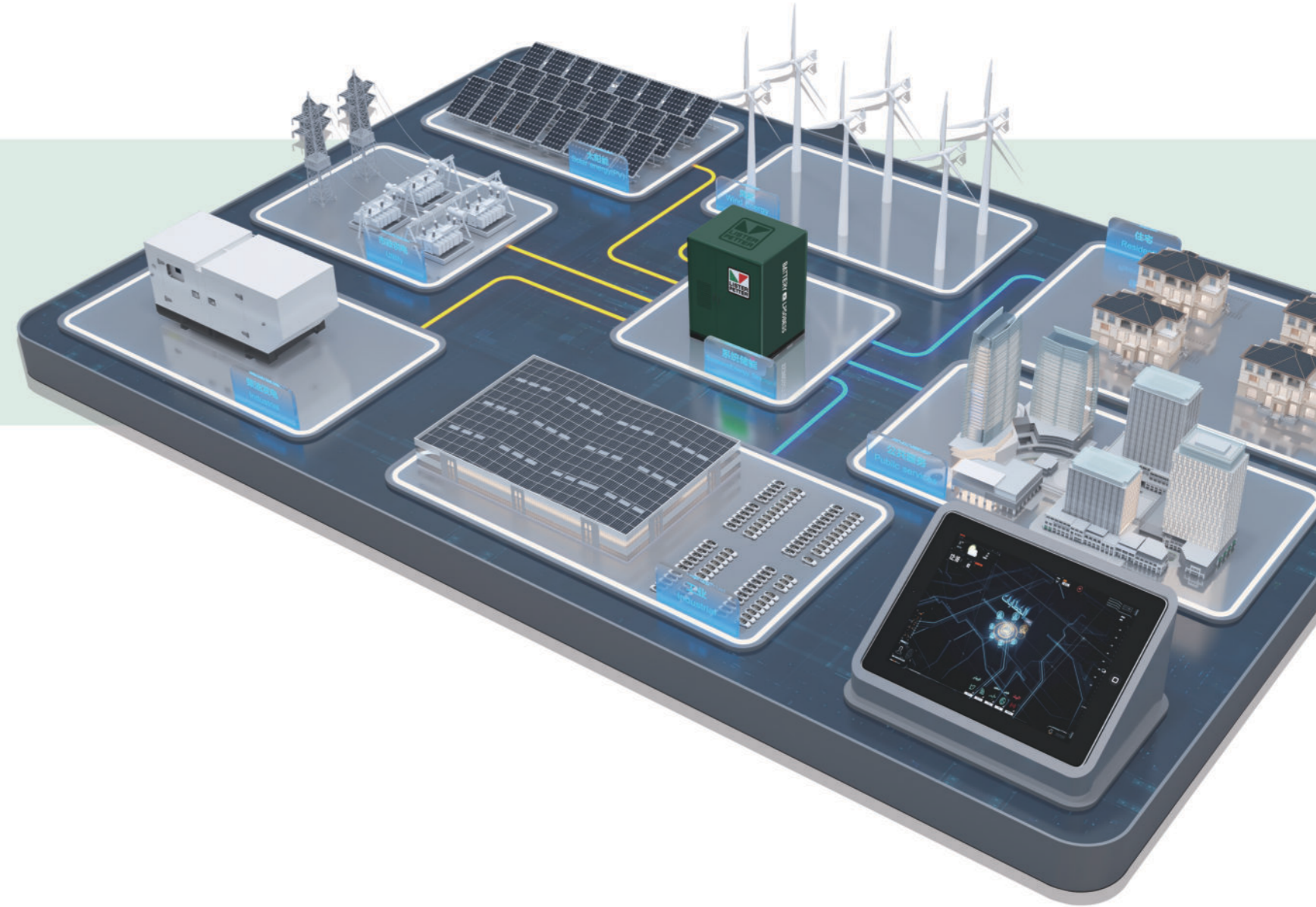

- ✓ Gas generator
- ✓ Diesel generator
- ✓ BESS
- ✓ Solar components
- ✓ Hybrid generator(Solar+DG+BESS)
- ✓ Micro Grid

COMPANY BACKGROUND

Lister Petter is committed to developing new and innovative solutions to provide cleaner energy. By utilizing emerging technologies alongside our more traditional methods, we aim to meet the ever-changing power demands of the world and drive towards zero carbon emissions.



CLIENT END



• Overview

The Lister Petter string energy storage system can provide customers with peak-to-valley arbitrage mode and backup power guarantees, as well as dynamic capacity expansion. This system can be applied to household energy storage, large industrial and commercial settings, 5G base stations, micro-grids, virtual power plants, and other livelihood areas. It helps customers reduce electricity costs, provides emergency protection, and promotes green energy for the benefit of all.

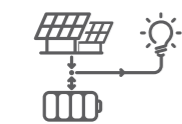

Self-consumption

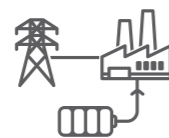

Time-of-use optimisation

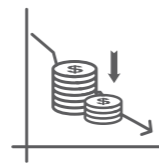

Reduce electricity costs

• Solar Energy Storage

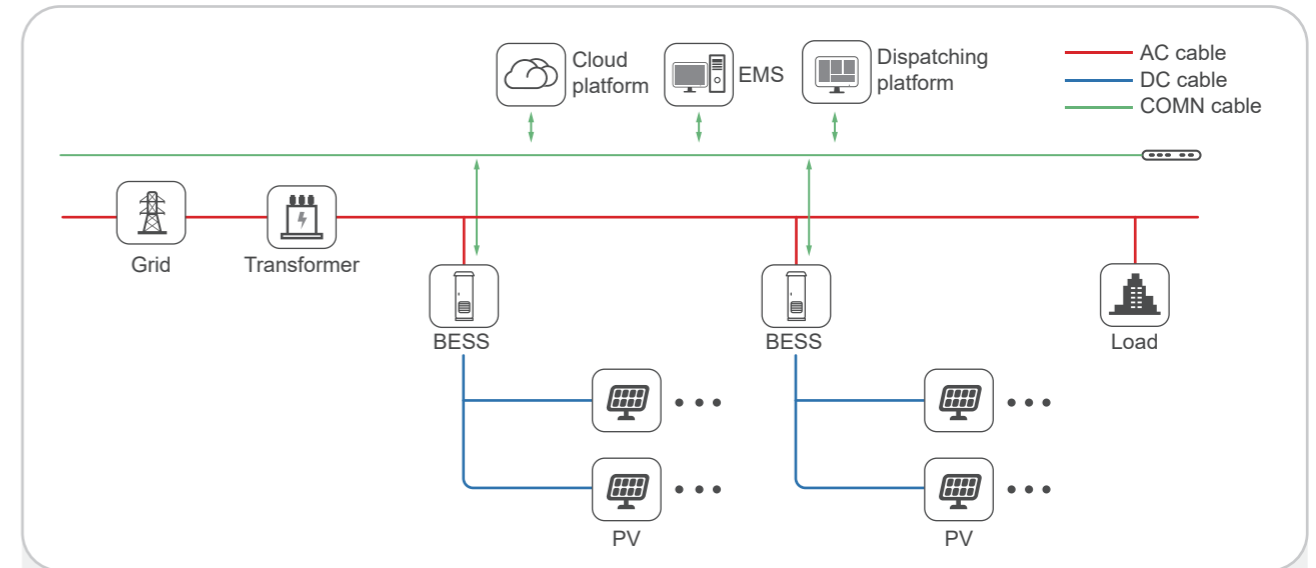

Applications:

- Electricity for remote areas
- Residential
- Commercial and industrial electricity
- Electricity for public places

Recommended products:

Option 1: BESS series (All-in-one solutions)

• Energy Storage Power Station

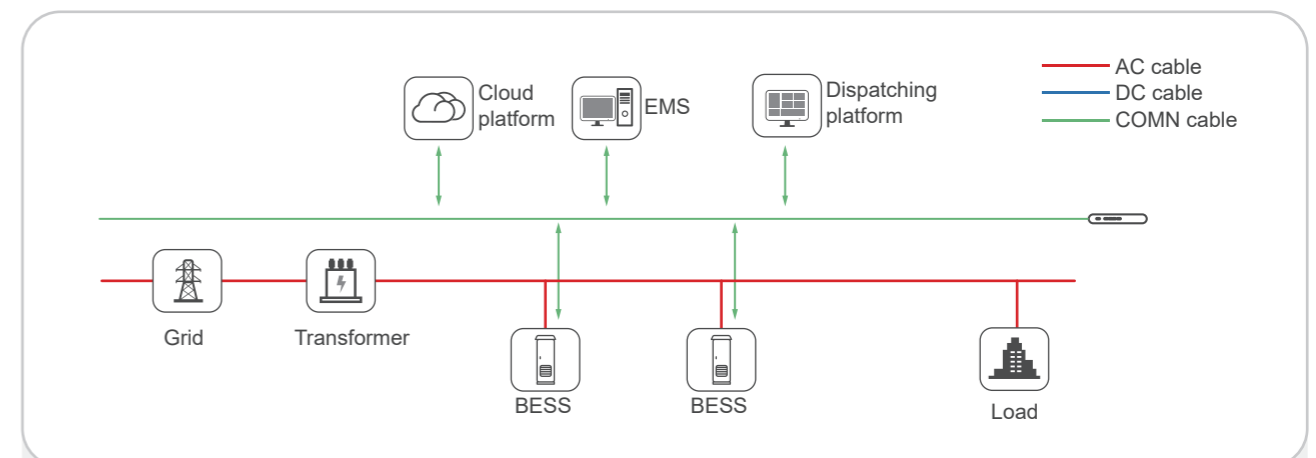

Applications:

- Peak shaving
- Load balancing
- Backup power

Recommended products:

Option 1: BESS series (All-in-one solutions)

GENERATION-SIDE END



• Overview

Energy storage plants play an important role on the generation side by providing a buffer between electricity generation and consumption. They allow excess energy to be stored when demand is low and released when demand is high, which can help improve the efficiency and reliability of power generation. It can also help mitigate the impact of intermittent renewable energy sources such as wind and solar. By storing excess energy generated during periods of high production, energy storage power plants ensure a consistent supply of electricity when these sources are not producing.

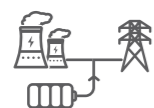

Load shifting



Renewable energy integration



Capacity stability

• Generation-Side Energy Storage

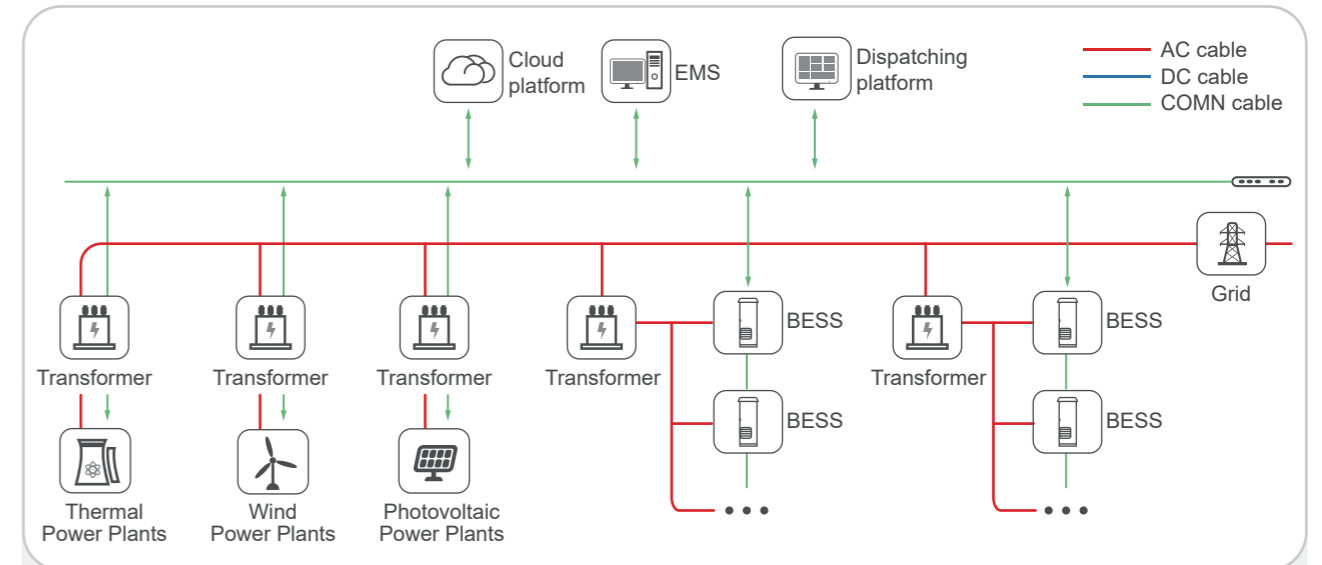

Applications:

- Load shifting
- Black start capability
- Renewable energy integration
- Capacity Stability
- Frequency regulation

Recommended products:

- BESS series (All-in-one solutions)

• Integrated PV Energy Storage Station

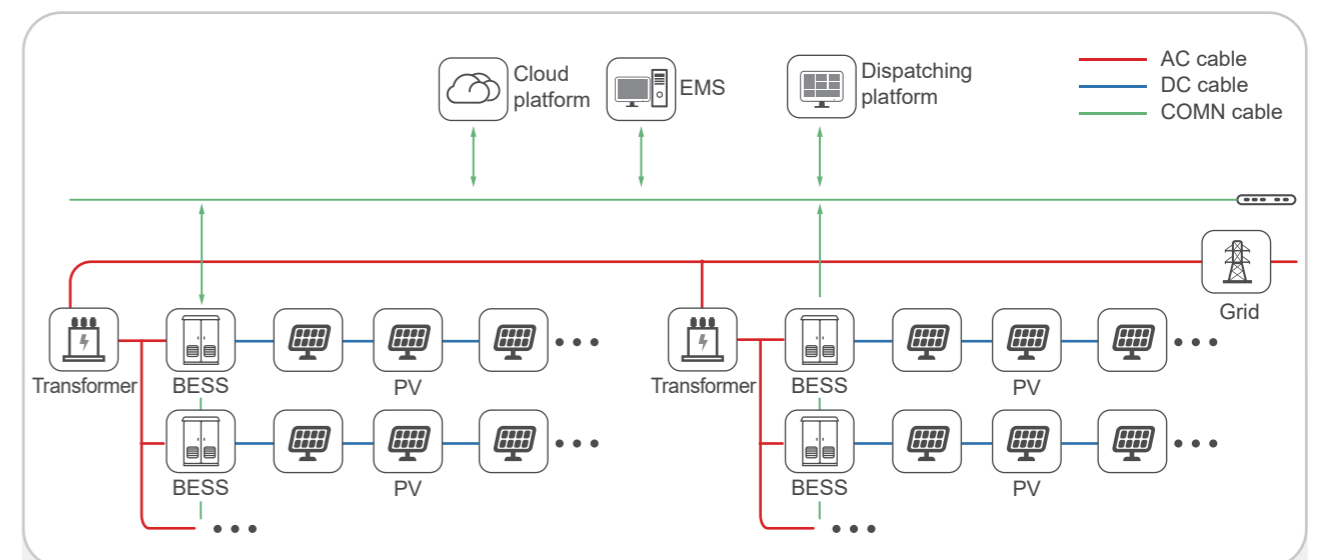

Applications:

- Renewable energy integration
- Capacity Stability
- Frequency regulation

Recommended products:

- BESS + MPPT

TRANSMISSION & DISTRIBUTION END



• Overview

A grid-scale energy storage plant plays a crucial role in improving the reliability and stability of the electricity grid. These power plants store excess energy during periods of low demand and release it during periods of high demand, helping to balance supply and demand on the grid. This capability reduces the need for expensive and less efficient peaking power plants, which are typically used only during periods of high demand.



Peak shaving



Black start capability



Ancillary services

• Power Station ESS Solutions

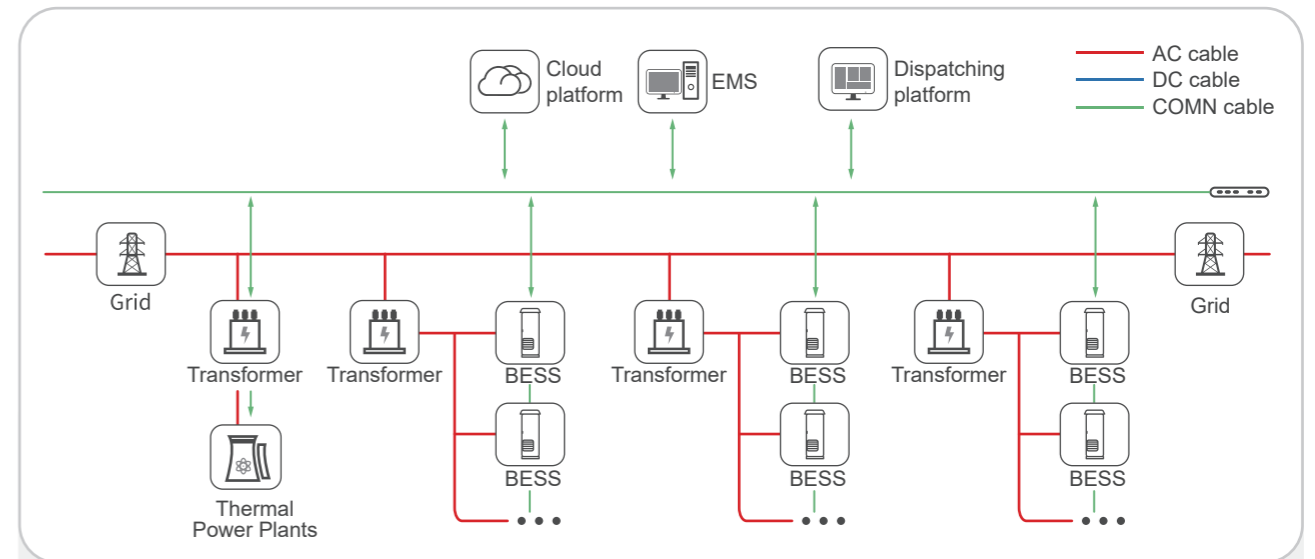

Applications:

- Peak shaving
- Frequency regulation
- Black start capability
- Ancillary services

Recommended products:

- BESS series (All-in-one solutions)

• Grid Station Area ESS Solutions

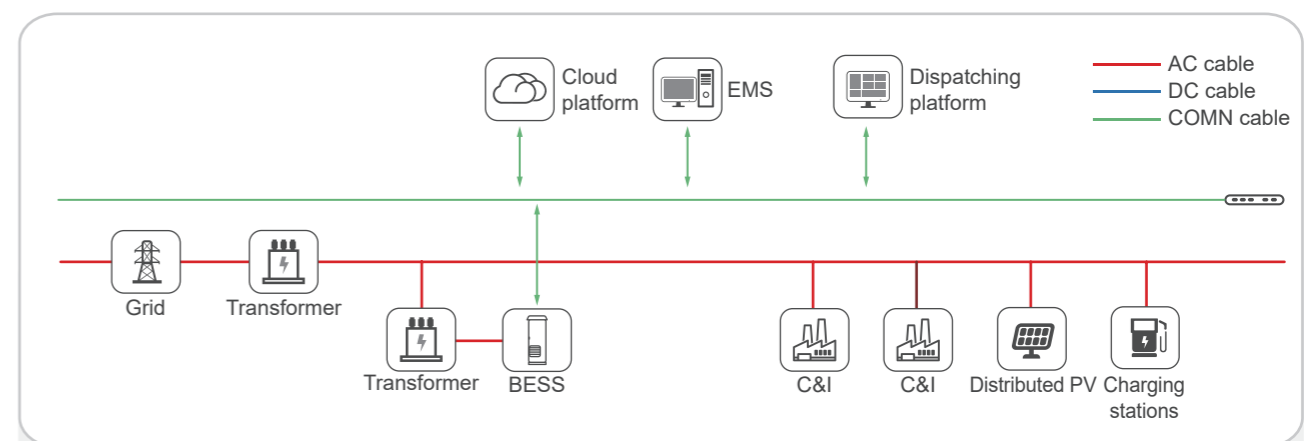

Applications:

- Peak shaving
- Renewable energy integration
- Frequency regulation
- Black start capability
- Ancillary services

Recommended products:

- BESS + transformer

MICROGRID ESS



SOLAR ENERGY BESS CHARGING STATION

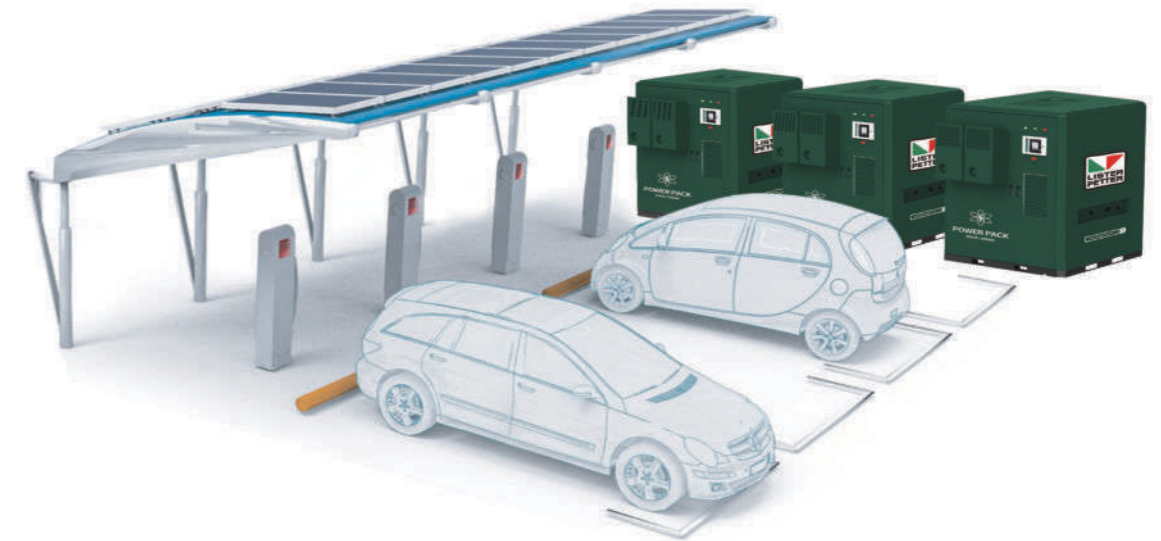

• Microgrid ESS

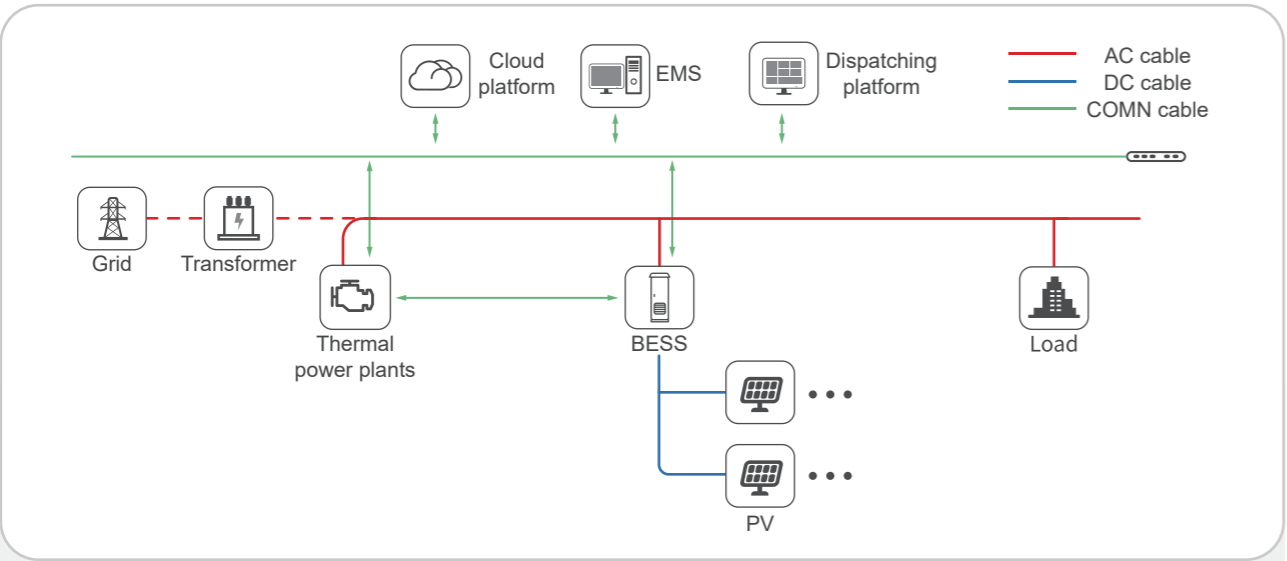

- Applications:**
- Remote communities
 - Hospitals and emergency services
 - Data centers
 - Industrial parks

- Recommended products:**
- Option 1: BESS + MPPT
 - Option 2: BESS series (All-in-one solutions)

• Solar Energy BESS Charging Station

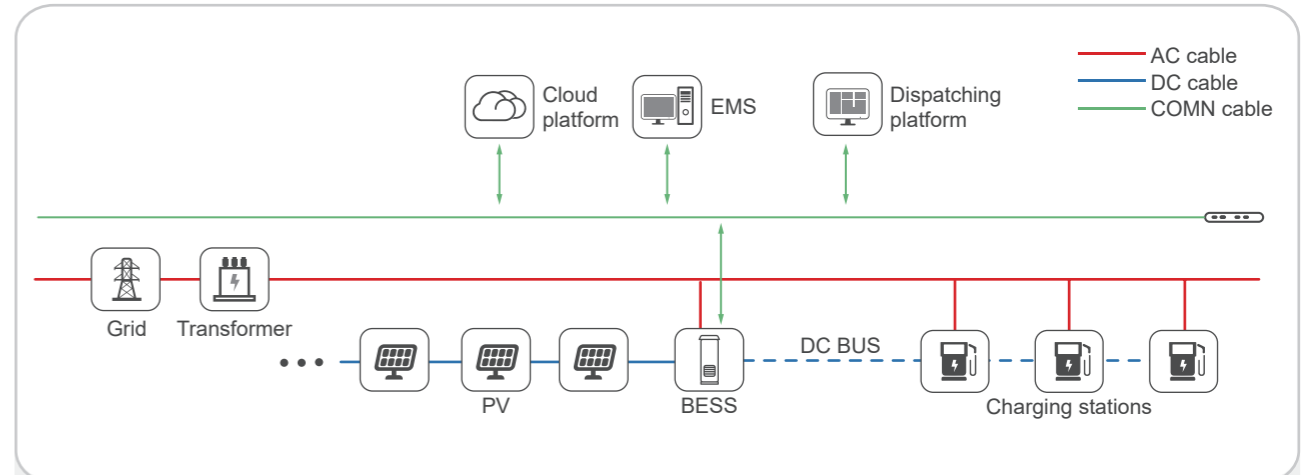

- Applications:**
- Providing backup power
 - Integrating renewable energy
 - Reducing peak demand
 - Improving energy sustainability
 - Creating microgrids

- Recommended products:**
- Option 1: BESS + MPPT
 - Option 2: BESS series (All-in-one solutions)

Demonstrations

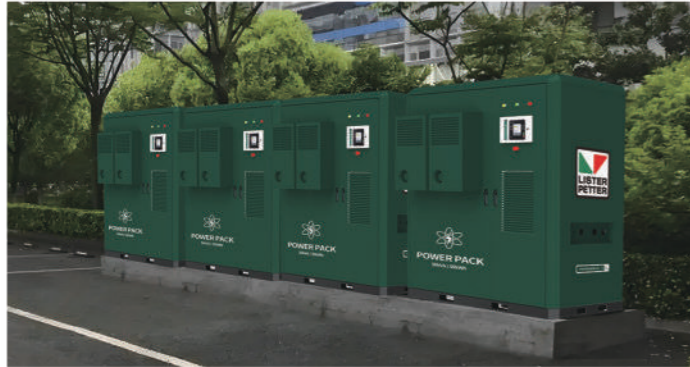

Energy Storage Power Station

Providing backup power

400kW / 800kWh

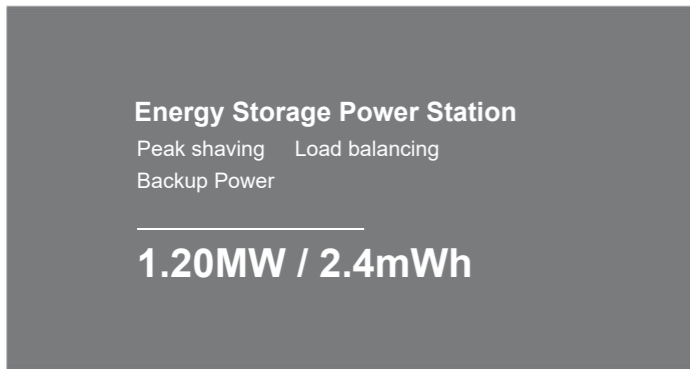

Energy Storage Power Station

Peak shaving Load balancing
Backup Power

1.20MW / 2.4mWh



Energy Storage Power Station

Reducing peak demand

200kW / 400kWh

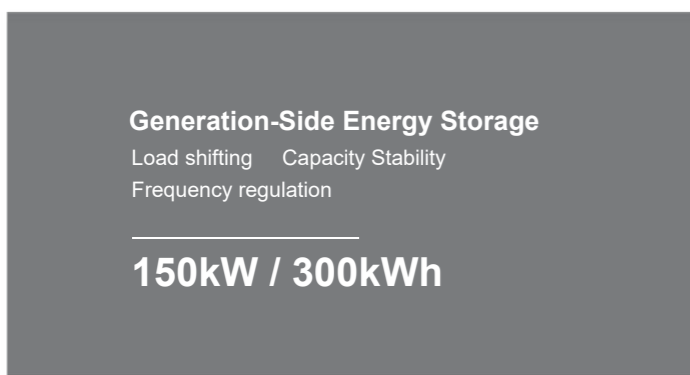

Generation-Side Energy Storage

Load shifting Capacity Stability
Frequency regulation

150kW / 300kWh

BESS

Hybrid Commercial and Industrial ESS

• Features

- All-in-one design with a high degree of integration.
- Modular design with optional modules of different sizes.
- Support for grid-connected and off-grid operation
- MPPT Solar controller available as an option
- IP54 class fire and explosion-proof housing
- Patented air duct design, intelligent air cooling, 3-5°C temperature difference of the battery core



• Applications



Self-Consumption



Off grid



Demand Charge



Back Up



DG+BESS



Micro-grid



Smooth output



Shaving

• 1 Hour Impact Load Regulation

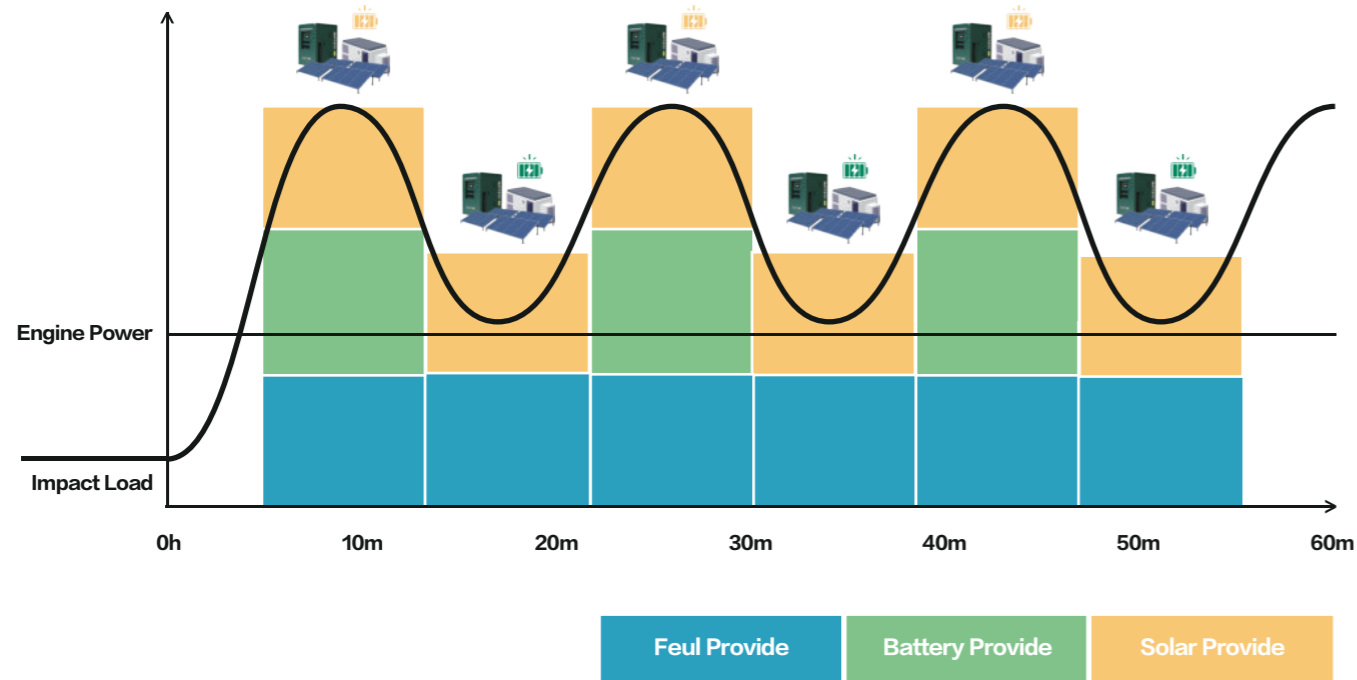

• 24 Hours Profile Construction Side

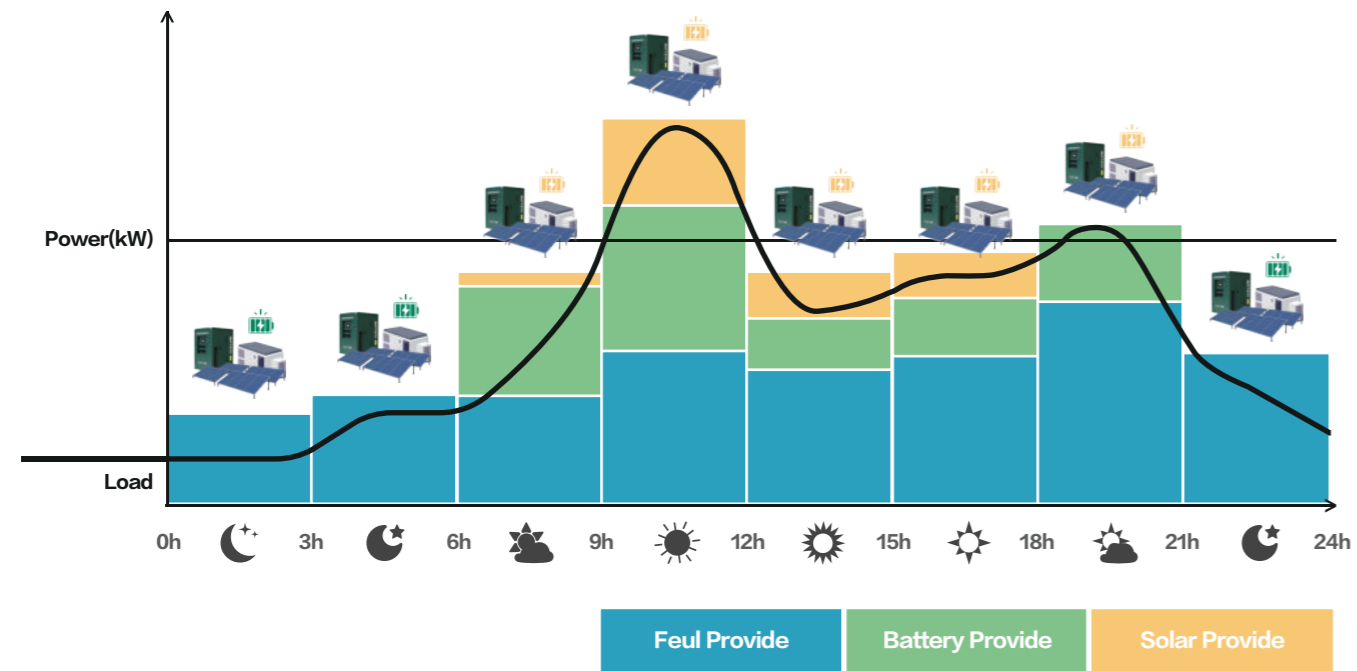

• Applications



Construction



Mine



Leasing



Port



Oil field



Hospital

Advantages

Optimized system performance

Energy Management

50-100% impact load regulation ability improvement
(Determined by BESS size)

Quiet Technology

The perfect choice for noise-sensitive applications and worksites, especially for overnight operation allowing increased productivity.

Cost Savings

Optimize fuel consumption and reduce the running time of engine. 30-50% fuel will be saved cause Engine will always running at high efficiency.



BESS SPECIFICATION

All in One Series

Distributed Air Cooled BESS System			
Model	LP50BESS	LP100BESS	LP200BESS
AC Output			
AC Voltage Range	230-400VAC +/-2%	230-400VAC +/-2%	230-400VAC +/-2%
Frequency Range	50Hz +/-0.5%	50Hz +/-0.5%	50Hz +/-0.5%
Stored Battery Power	50.4kWh	107kWh	215kWh
Inverter Rated Power	35kW	50kW	100kW
Continuous Power @25° C	35kW	50kW	100kW
Maximum Feed Through Current	3*63A	3*90A	3*180A
AC Output – Inverter			
AC Voltage Range	190-300VDC	600-850VDC	630-900VDC
Input Frequency	50Hz/60Hz ± 2.5Hz	50Hz/60Hz ± 2.5Hz	50Hz/60Hz ± 2.5Hz
Maximum Feed Through Current	3*63A	3*90A	3*180A
Weight	35kg	40kg	50kg
Dimension(mm)	480(W)*173(H)*550(D)	480(W)*176(H)*620(D)	480(W)*176(H)*620(D)
Connections			
Input	1*32A(3 phases)	1*63A(3 phases)	1*125A(3 phases)
Output	2*32A(3 phases) 1*63A(3 phases)	2*63A(3 phases) 1*125A(3 phases)	1*63A(3 phases) 2*125A(3 phases)
Battery			
Charging & Discharging Cycle Efficiency	0.5	0.5	0.5
Cellular specification	314Ah 51.2V	280Ah 51.2V	280Ah 51.2V
Usable Capacity	16kWh	14.3kWh	14.3kWh
Norminal Output	8kW	7.15kW	7.15kW
Norminal Voltage	51.2VDC	51.2VDC	51.2VDC
Efficiency	95%	95%	95%
Battery Managment System	Yes	Yes	Yes
Active Balancing System	Yes	Yes	Yes
Voltage Range	48.8-57.6V	48.8-57.6V	48.8-57.6V
Communication Interfaces	RS485/CAN	RS485/CAN	RS485/CAN
Life Span Cycle	5000 (+25°C, 0.5C)	5000 (+25°C, 0.5C)	5000 (+25°C, 0.5C)
Weight	103 ± 1.5kg	103 ± 1.5kg	103 ± 1.5kg
Dimension(mm)	753.1(L)*476.0(W)*230.0(H)	753.1(L)*476.0(W)*230.0(H)	753.1(L)*476.0(W)*230.0(H)
General Data			
Dimension(mm)	1350(W)*1500(H)*1100(D)	1810(W)*1800(H)*1100+300(D)	1810(W)*2250(H)*1100+300(D)
Weight	1116kg	1987kg	2870kg
Compatible Diesel Generator			
Rated Power	≤25 kW	≤50 kW	≤100 kW
Rated Voltage	400 / 480V	400 / 480V	400 / 480V
Rated Frequency	50 / 60 Hz	50 / 60 Hz	50 / 60 Hz



BESS SPECIFICATION

All in One Series

Distributed Air Cooled BESS System			
Model	LP250BESS	LP350BESS	LP400BESS
AC Output			
AC Voltage Range	230-400VAC +/-2%	230-400VAC +/-2%	230-400VAC +/-2%
Frequency Range	50Hz +/-0.5%	50Hz +/-0.5%	50Hz +/-0.5%
Stored Battery Power	261kWh	366kWh	430kWh
Inverter Rated Power	125kW	125kW	200kW
Continuous Power @25° C	125kW	125kW	200kW
Maximum Feed Through Current	3*225A	3*225A	3*360A
AC Output – Inverter			
AC Voltage Range	600-1000VDC	1000-1500VDC	[630-900VDC]*2
Input Frequency	50Hz/60Hz ± 2.5Hz	50Hz/60Hz ± 2.5Hz	[50Hz/60Hz ± 2.5Hz]*2
Maximum Feed Through Current	3*225A	3*225A	[3*180A]*2
Weight	50kg	115kg	[50kg]*2
Dimension(mm)	520(W)*186(H)*680(L)	750(W)*275(H)*820(D)	960(W)*176(H)*620(D)
Connections			
Input	1*250A Plastic shell breaker	1*315A Plastic shell breaker	1*375A(3 phases)
Output	1*63A(3 phases) 2*125A(3 phases)	2*63A(3 phases) 2*125A(3 phases)	2*63A(3 phases) [2*125A(3 phases)]*2
Battery			
Charging & Discharging Cycle Efficiency	0.5	0.5	0.5
Cellular specification	314Ah 51.2V	314Ah 51.2V	314Ah 51.2V
Usable Capacity	16kWh	16kWh	16kWh
Norminal Output	8kW	8kW	8kW
Norminal Voltage	51.2VDC	51.2VDC	51.2VDC
Efficiency	95%	95%	95%
Battery Managment System	Yes	Yes	Yes
Active Balancing System	Yes	Yes	Yes
Voltage Range	48.8-57.6V	48.8-57.6V	48.8-57.6V
Communication Interfaces	RS485/CAN	RS485/CAN	RS485/CAN
Life Span Cycle	5000 (+25°C, 0.5C)	5000 (+25°C, 0.5C)	5000 (+25°C, 0.5C)
Weight	103 ± 1.5kg	103 ± 1.5kg	103 ± 1.5kg
Dimension(mm)	753.1(L)*476.0(W)*230.0(H)	753.1(L)*476.0(W)*230.0(H)	753.1(L)*476.0(W)*230.0(H)
General Data			
Dimension(mm)	1100*1400*2400	10-Foot Containers	10-Foot Containers
Weight	2.6T	4T	8.5T
Compatible Diesel Generator			
Rated Power	≤125 kW	≤175 kW	≤200 kW
Rated Voltage	400 / 480V	400 / 480V	400 / 480V
Rated Frequency	50 / 60 Hz	50 / 60 Hz	50 / 60 Hz



BESS SPECIFICATION

All in One Series

Distributed Air Cooled BESS System

Model	LP500BESS
Stored Battery Power	522kWh

Battery

Cell Type	LFP(LiFePO4)
Pack Capacity	52.25kWh
Pack Rated Voltage	166.4VDC
Cyclic Life	8000(0.5C@90%DOD)
Battery Voltage of Rack	832VDC
Connection of Rack	5S4P

PCS

Max. Current (AC)	728A
Max. Output Power	600kW
Rated Output Power	500kW
AC Input Voltage Range	380-415Vac
Rated Frequency Range	50/60Hz(±2.5Hz)
PF	1 lagging-1 leading
AC Connection	3W+N+PE
Max. Efficiency	99%
Transformer	NA
Communication	CAN/RS485
Grid-tied Certificates	EN50549,NRS 097, C10/11,VDE4105, G99
Safety & EMC Certificates	IEC61000, IEC62477

EMS

Display and Monitor	Local screen
Function	Energy management and coordinated control of energy storage system

General Data

Dimension(mm)	10-Foot Containers
Weight	9T

Compatible Diesel Generator

Rated Power	≤250 kW
Rated Voltage	400 / 480V
Rated Frequency	50 / 60 Hz



BESS SPECIFICATION

All in One Series

Distributed Air Cooled BESS System

Model	LP600BESS
Stored Battery Power	627kWh

Battery

Cell Type	LFP(LiFePO4)
Pack Capacity	52.25kWh
Pack Rated Voltage	166.4VDC
Cyclic Life	8000(0.5C@90%DOD)
Battery Voltage of Rack	832VDC
Connection of Rack	5S4P

PCS

Max. Current (AC)	728A
Max. Output Power	600kW
Rated Output Power	500kW
AC Input Voltage Range	380-415Vac
Rated Frequency Range	50/60Hz(±2.5Hz)
PF	1 lagging-1 leading
AC Connection	3W+N+PE
Max. Efficiency	99%
Transformer	NA
Communication	CAN/RS485
Grid-tied Certificates	EN50549,NRS 097, C10/11,VDE4105, G99
Safety & EMC Certificates	IEC61000, IEC62477

EMS

Display and Monitor	Local screen
Function	Energy management and coordinated control of energy storage system

General Data

Dimension(mm)	10-Foot Containers
Weight	10T

Compatible Diesel Generator

Rated Power	≤300 kW
Rated Voltage	400 / 480V
Rated Frequency	50 / 60 Hz



BESS SPECIFICATION

All in One Series



BESS SPECIFICATION

All in One Series

Distributed Air Cooled BESS System

Model	LP1000BESS
Stored Battery Power	1044kWh

Battery

Rated Output Power@25°C	500kW
Rated Output Voltage	400V@50Hz,3ph
Battery Storage Capacity	1003.5kWh
Operating Temperature Range	-20~50°C(> 45°C derating)
Max altitude	3000m(> 2000m derating)
Cell Type	LFP(LiFePO ₄)
Pack Model	MF51280
Pack Capacity	14.336kWh
Pack Rated Voltage	51.2VDC
Cyclic Life	6000(0.5C@90%DOD)
Charger/Discharge Current	140A(0.5C)
Battery Voltage of Rack	716.8VDC
Connection of Pack	14S5P

PCS

Battery Voltage Range	600~900VDC
Max. Current (AC)	794A
Max. Output Power	550kW
Rated Output Power	500kW
Rated Voltage	400Vac
Rated Frequency Range	50/60Hz(± 2.5Hz)
PF	1 lagging-1 leading
AC Connection	3W+N+PE
Max. Efficiency	98.2%
Transformer	Optional
Communication	CAN/RS485/Ethernet/WIFI
Certificates	CE LVD IEC 62477, CE EMC IEC 61000

General Data

Dimension(mm)	20' GP
Weight	18T

Compatible Diesel Generator

Rated Power	≤500 kW
Rated Voltage	400 / 480V
Rated Frequency	50 / 60 Hz

Distributed Air Cooled BESS System

Model	LP1500BESS
Stored Battery Power	1520kWh

Battery

Rated Output Power@25°C	500kW
Rated Output Voltage	400V@50Hz,3ph
Battery Storage Capacity	1505.28kWh
Operating Temperature Range	-20~50°C(> 45°C derating)
Max altitude	3000m(> 2000m derating)
Cell Type	LFP(LiFePO ₄)
Pack Model	MF51280
Pack Capacity	14.336kWh
Pack Rated Voltage	51.2VDC
Cyclic Life	6000(0.5C@90%DOD)
Charger/Discharge Current	140A(0.5C)
Battery Voltage of Rack	768VDC
Connection of Pack	15S7P

PCS

Battery Voltage Range	600~900VDC
Max. Current (AC)	794A
Max. Output Power	550kW
Rated Output Power	500kW
Rated Voltage	400Vac
Rated Frequency Range	50/60Hz(± 2.5Hz)
PF	1 lagging-1 leading
AC Connection	3W+N+PE
Max. Efficiency	98.2%
Transformer	Optional
Communication	CAN/RS485/Ethernet/WIFI
Certificates	CE LVD IEC 62477, CE EMC IEC 61000

General Data

Dimension(mm)	20' GP
Weight	25.3T

Compatible Diesel Generator

Rated Power	≤725 kW
Rated Voltage	400 / 480V
Rated Frequency	50 / 60 Hz



BESS SPECIFICATION

All in One Series

Distributed Air Cooled BESS System

Model	LP2000BESS
Stored Battery Power	2280kWh

Battery

Rated Output Power@25°C	1000kW
Rated Output Voltage	400V@50Hz,3ph
Battery Storage Capacity	2007.04kWh
Operating Temperature Range	-20~50°C(> 45°C derating)
Max altitude	3000m(> 2000m derating)
Cell Type	LFP(LiFePO ₄)
Pack Model	MF51280
Pack Capacity	14.336kWh
Pack Rated Voltage	51.2VDC
Cyclic Life	6000(0.5C@90%DOD)
Charger/Discharge Current	140A(0.5C)
Battery Voltage of Rack	716.8VDC
Connection of Pack	14S10P

PCS

Battery Voltage Range	600~900VDC
Max. Current (AC)	794A
Max. Output Power	1100kW
Rated Output Power	1000kW
Rated Voltage	400Vac
Rated Frequency Range	50/60Hz(±2.5Hz)
PF	1 lagging-1 leading
AC Connection	3W+N+PE
Max. Efficiency	98.2%
Transformer	Optional
Communication	CAN/RS485/Ethernet/WIFI
Certificates	CE LVD IEC 62477, CE EMC IEC 61000

General Data

Dimension(mm)	20' GP
Weight	30T

Compatible Diesel Generator

Rated Power	≤ 1000 kW
Rated Voltage	400 / 480V
Rated Frequency	50 / 60 Hz



BESS SPECIFICATION

All in One Series

Distributed Air Cooled BESS System

Model	LP5000BESS
Stored Battery Power	5015kWh

Battery

Battery Stack	12*1P416S
Rated Voltage	1331.2VDC
DC Voltage Range	1164.8VDC~1497.6VDC
Charge/Discharge Rate	0.5P
Protection Class	IP54
Loading Capacity 20' GP	1 units
Discharge Temperature Range	-20~50° C(> 40°C derating)
Humidity	0~95%(No Condensation)
Max Altitude	≤2000m
Dimension(mm)	2438mm*6058mm*2896mm(ISO 20' HQ)
Cell Type	LFP(LiFePO ₄)
Cell Capacity	314Ah
Pack Capacity	104.5 kWh
Pack Rated Voltage	332.8 VDC
Cyclic Life	8000 Times(0.5C@80%DOD)
Battery Voltage of Rack	1331.2 VDC
Rack Capacity	417.99 kWh
Connection of Pack	416S1P

Cooling System

Battery Cabin	Liquid Cooling
Liquid-cooled unit	60kW
Quantity	1

Protection Device

Fire Suppressant	Aerosol (CE), water inlet valve reserved
DC Side	Disconnect Switch & Fuse
Sensor	Smoke, temperature, Gas detector

High-Voltage Box

High-Voltage Box	250A/1500V
Quantity	12

General Data

Dimension(mm)	40' GP
Weight	44T
Certificates	CE LVD IEC 62477, CE EMC IEC 61000

Compatible Diesel Generator

Rated Power	≤2500kW
Rated Voltage	400 / 480V
Rated Frequency	50 / 60 Hz