



2024 NRSS RULE BOOK©
Northern Renegade Sprint Car Series

GENERAL, SAFETY AND EVENT RULES
TRADITIONAL SPRINT SPECIFICATIONS
WING SPRINT SPECIFICATIONS

Revised: February 4, 2024

(Changes are highlighted)

TABLE OF CONTENTS

GENERAL, SAFETY AND EVENT RULES	3
NRSS Officials	3
Spirit of the Rule	3
Rule Book Disclaimer	3
Participant Specifications	4
Conduct and Sportsmanship	5
Car and Driver Safety Requirements	8
Order of Events	11
Race Procedures	11
Point Chart	13
Event Rules	13
Engine Protest Rule	18
Flags	19
TRADITIONAL SPRINT SPECIFICATIONS	21
Engine Specifications	21
360 Engine	21
5.3 Liter LS Engine	24
GM 602 Sealed Engine	27
Engine Sealing Program	27
Dyno Rule	27
Car Construction & Chassis Specifications	27
WING SPRINT SPECIFICATIONS	31
Engine Specifications	31
360 Engine	31
RaceSaver 305 Engine	34
5.3 Liter LS Engine	35
Chevrolet 604 Crate Engine	38
Engine Sealing Program	38
Car Construction & Chassis Specifications	38
Wing Specifications	38

GENERAL, SAFETY AND EVENT RULES

NRSS OFFICIALS

President: Caley Emerson (218-398-7807)

Technical Director: Caley Emerson / TBA

Race Director: TBA

SPIRIT OF THE RULE

Although every effort has been made to provide complete, accurate, and clearly written rules, the NRSS cannot possibly anticipate every situation or circumstance. With this constraint in mind, the NRSS will use the “Spirit of the Rule” in all decision-making processes. The “Spirit of the Rule” refers to the original intent of every rule and classification. Additional adjustments, alterations, modifications, and/or replacements not covered by written rules should not be assumed to be legal under the “Spirit of the Rule.” The “Spirit of the Rule” will be the final criteria by which rules will be interpreted and enforced.

RULE BOOK DISCLAIMER

The rules and/or regulations set forth herein are designed to provide for the orderly conduct of racing events, and to establish minimum acceptable requirements for such events. The rules shall govern the condition of all events and, by participating in these events, all participants agree to comply with the rules. No expressed or implied warranty of safety shall result from publication of, or compliance with, the rules and/or regulations. The rules are intended as a guide for the conduct of the sport, and are in no way a guarantee against injury or death to a participant, spectator, or official.

NRSS officials are empowered to permit deviations from any of the specifications herein, or to impose further restrictions that, in the official’s opinion, do not alter the minimum acceptable requirements. No express or implied warranty of safety shall result from such alteration of specifications. All interpretations or deviations of the rules is left to the discretion of the NRSS officials. The NRSS official’s decision is final.

NRSS Technical Officials shall have full authority, at the discretion of the NRSS official in charge, to make decisions on behalf of the NRSS. A NRSS Technical Official may disqualify any competitor, at any time, for rule violations, hazardous equipment, or hazardous actions. Vehicles approved for competition by a NRSS Technical Official is not a guarantee that the inspected vehicle is mechanically sound. NRSS Technical Officials shall not be liable for any mechanical failure nor for any losses, injuries or death resulting from inspections.

PARTICIPANT SPECIFICATIONS

License

All drivers competing in a NRSS event must have a current NRSS sprint car drivers' license. A driver will not be allowed on the race surface until a completed license application is turned into the NRSS. The license application is available at www.nrsprints.com. The cost of an annual license/insurance is noted on the application. Also, each season IRS form W-9 must be on file before a driver can receive a check.

Age Restriction

Drivers must be at least 17 years old to compete in either sprint car division. A driver that is 14 - 16 years old that has previous experience may be given permission by the series owner for a 3-race trial period. If the driver's ability is deemed satisfactory during the trial, the driver will be allowed to continue to participate. Race track management may also have age constraints that override the NRSS age limits. If there is a question on age constraints at any particular race track, drivers should check with track management to determine age restrictions at the track in which the driver wants to compete.

Participant

Each and every driver, car owner, sponsor, mechanic, crew member, or any other pit personnel taking part in any NRSS-sanctioned racing event is a participant. All such participants are voluntarily involved in a NRSS-sanctioned racing event, with the full understanding that all participants must abide by all of the rules and regulations of the NRSS. By voluntarily participating in a NRSS-sanctioned racing event, all participants acknowledge that they are fully aware of the risks involved in the sport of auto racing, and that by participating in such a racing event, they assume all such risks. This acknowledgment extends to all licensed NRSS drivers entering the pit area whether racing or not.

Any driver that makes, or has previously made, part or all of their living driving a sprint car or any other type of race car, is not eligible to drive in any NRSS event. These drivers are allowed to compete in the High Roller Series.

Rookies

For their first three race nights, all rookies will start each race from the back of the field. Rookies may be started at the back for more than three weeks at the discretion of NRSS officials. **In addition, rookies must display a NRSS rookie flag on their race car for the entirety of the rookie's first season. Drivers with little or no previous racing experience will be required to use a restrictor plate provided by the series, at no cost to the team. The plate remains the property of NRSS and must be returned in good, unaltered shape for return of deposit money.**

Transponders

A functional transponder is mandatory and must be mounted vertically, behind the most forward right front upright of the frame. (typically, the front axle, frame side, panhard bar mount)

Radios

The use of a functional Raceceiver **type** radio by all drivers in competition is mandatory.

Drivers' Meeting

All drivers must attend the drivers' meeting. Any foreseeable changes to the program or format will be announced at the drivers' meeting, if possible, at that time. Announced changes will always take precedence over the written rules for that event. The draw will be held either by the track or by the NRSS immediately following the drivers' meeting. **Drivers that miss the drivers' meeting may not be allowed to draw or compete**, at the discretion of the NRSS officials.

Decals

All cars must display the official NRSS sponsor decals. Cars must display decals on the outside of both of the side panels of the top wing, on both sides of the body of the car, or as designated by the NRSS. If current decals are included in your wrap, decals must be the same size and color as the ones provided by the series (minimum of 11 inches long x 4 inches wide). As a show of appreciation for a sponsor's contribution to the NRSS, car owners are highly encouraged to display NRSS sponsor decals in such a way that it benefits the sponsor. Not displaying series' sponsors decals may result in disqualification.

CONDUCT & SPORTSMANSHIP

Conduct

All NRSS participants are guests at each track the NRSS visits. All participants are reminded to conduct themselves accordingly. **This includes leaving your pit stall clean and free of garbage.**

Driver Responsibility

The driver is responsible for the actions of the driver's pit crew. The driver shall be the sole spokesperson for the car owner and pit crew in any and all matters, and will be accountable to the NRSS and track officials in all matters regarding team members' conduct or behavior. If the driver is legally a minor, duty of responsible spokesperson shall be the legal adult guardian of the driver.

Drugs and Alcohol

The use of illegal drugs is prohibited. The consumption of alcoholic beverages before the entire racing program has completed is prohibited. Race track management may also have rules that further restrict alcoholic beverage consumption in pit areas. As a guest of the race track, all NRSS participants will comply with race track rules.

Smoking

No driver, or anyone else, is allowed to smoke while sitting in the car.

Abusive Behavior and Unsportsmanlike Conduct

Sprint car racing is an extremely emotional sport. The spirit of sportsmanship is the cornerstone of any competitive racing program, and professional conduct of all participants is expected. The expectation of professional conduct includes respect for all participants, drivers, owners, pit crews, sponsors, track personnel and NRSS officials. The NRSS will always strive to be consistent when making decisions, no matter what or who is involved, and will treat all participants with respect. Similar conduct from participants is expected in return. Fighting, harassing, or verbally abusing any NRSS official, security personnel, safety worker, firefighter, tow truck operator, push truck operator, race track worker, or race track management will not be tolerated.

No participant shall engage in improper behavior on or off the track, while in or out of the race car. No participant shall subject any NRSS official, track official, track employee, sponsor, or participant to any abusive or improper language at any time. No driver shall get out of their race car to verbally assault or threaten any NRSS official, track official, track employee, sponsor or any other participant.

A participant is considered at fault if in a competitor's pit area without an invitation, or is in a tech area without having a car present for tech.

Examples of Unacceptable Behavior

- Attempting to, or physically abusing any event official, including pushing, punching, touching, grabbing and/or grabbing the official's equipment, etc.
- Verbally abusing any event official.
- Pushing a racecar off from the wrong area and/or not stopping in the designated area as to cause undue confusion and/or delay.
- Failing to stop for, and/or allow a post-race inspection.
- Attempting to drive roughly, and/or bumping another competitor unnecessarily.
- Attempting to use unapproved fuel.
- Attempting, and/or using tires that are found to be unapproved in any manner.
- Attempting to, or using an unapproved engine.
- Failing to quickly stop for a red flag, or driving through the incident area.
- Going into another competitor's pit area, or to another competitor's car, and becoming involved in any type of altercation.
- Involvement in an altercation that results in physical contact.
- Driving a racecar in an area that is closed to race car traffic, or driving through the pit area at excessive speed in either a race car, scooter, or 4-wheeler.
- Entering the racing surface or infield without permission under a controlled period.
- Ignoring a flag or official signal.
- Violating any substance abuse rule at any event.
- Any behavior at or away from the track deemed detrimental to the NRSS.

Violation of Spirit and Intent of Rules & Unsportsmanlike Conduct

Any participant who defies or violates the intent or spirit of the NRSS rules shall be considered to have engaged in unsportsmanlike conduct and shall be dealt with by the NRSS, or track officials, all depending upon the nature of the infraction. Unsportsmanlike conduct is a non-appealable offense.

Reserved Participation Right

The NRSS, and the track promoter, reserves the right to refuse to accept the entry of any car or participant. Furthermore, the NRSS, and the track promoter, reserves the right to revoke or cancel any entry, or any participant's claimed right to be on the track premises, if it is determined that a participant's presence or conduct is not in the best interest of the sport of auto racing, the other competitors, the spectators, track management, event employees, or the NRSS.

Penalties

In an effort to encourage professional conduct at NRSS events, the following system of penalties shall apply:

- NRSS officials shall be empowered to immediately disqualify any competitor for the remainder of the event, and impose a suspension of up to one year. NRSS officials shall also be empowered to impose a penalty of up to \$2,500.
- Disqualification will include loss of all prize money.

Finality of Decisions and Interpretations, and a Covenant Not to Sue

The decisions of the NRSS officials, or track officials, at a NRSS-sanctioned event, shall be final, binding, and cannot be appealed. This includes the way the rules are interpreted, application of the rules, and the scoring of positions.

All participants, as a condition of participating in a NRSS-sanctioned racing event, agree that all decisions of NRSS race officials, or track officials, regarding the interpretation and application of the NRSS rules, and the scoring of positions, will not be litigated. All participants further agree that they will not initiate any type of legal action against the NRSS, or a NRSS promoter, to challenge such decisions, to seek monetary damages, to seek injunctive relief, or to seek any other kind of legal remedy. If a participant pursues any such legal action which violates this provision, the participant expressly agrees to reimburse the NRSS, or the NRSS promoter, for all of its attorney's fees and costs in defending against such legal action.

Off-Track Actions

Sportsmanship does not just pertain to activities at the track. As a competitor with the NRSS, drivers, team members and family members are expected to act professionally at all times. The same sportsmanship expected while competing at race facilities, as documented in the NRSS Rule Book, applies to the publication of public media content, social media content, and online activities. When creating and publishing public content, social media content, or online content, the content must be in accordance with the spirit of sportsmanship expected of all NRSS competitors, or it will be considered an act of unsportsmanlike conduct. Any conduct, including the publication of public

content, social media content, or online content, that adversely affects the NRSS, NRSS officials, sponsors, or other competitors, may result in disciplinary action up to and including a suspension and fine. This guidance also pertains to NRSS officials and NRSS employees.

CAR & DRIVER SAFETY REQUIREMENTS

On-Track Incident

If you are involved in an on-track incident, **DO NOT EXIT YOUR SPRINT CAR UNLESS IT IS ON FIRE OR YOU ARE INSTRUCTED TO DO SO BY AN OFFICIAL.** Any driver that exits their car after it has been pushed onto the race surface for reasons other than the above will not be allowed to continue in that race and will be scored in the appropriate spot for passing points and pay.

Mandatory Equipment

- Fuel bladder
- Fuel shut off valve. **Needs to be located on the dash or under the steering wheel.**
- Full containment racing seat
- Quick release steering wheel
- Racing approved 5-point seat belt restraints that are no more than three years old or manufacturers recommendation. **Reviewing and adhering to the guidelines described in the following hyperlinks is strongly recommended.** Seat belts **must** be properly installed.
 - <https://www.simpsonraceproducts.com/blog/pages/installation-guides> (under Harnesses, refer to the manuals on mounting brackets, seating positions, and web installation)
 - <https://www.butlerbuilt.net/Content/Images/uploaded/how-topdfs/PROPER%20Seat%20and%20Seat%20Belt%20Mounting-SPRINT.pdf>
- A full coverage racing helmet (Snell rated SA15 or SA2015 or newer) required. (SA2015 will be allowed through the 2024 season.)
- A minimum 2-layer approved fire suit, shoes, stocking, underwear, helmet skirt or head sock and Nomex gloves meeting acceptable industry standards is required.
- Arm restraints
- Raceceiver **type** radio
- Rock screen
- Transponder
- There must be a minimum of 2" clearance between the top of the driver's helmet and the top of the sprint car frame with the driver sitting upright and squarely in the car. If 2" of clearance does not exist, a sprint car halo with 2" of clearance between the top of the driver's helmet and the bottom of the halo bar must be properly installed in accordance with industry standards. 4" of clearance is strongly recommended. Any racing seat with more than one half inch of padding will require additional clearance.
- A fire extinguisher, suitable for use with methanol and oil fires, must be charged, staged, and readily accessible on all race trailers, 4-wheelers, and push vehicles.

- Side safety bars. We highly recommend that you contact your chassis manufacturer for proper installation of one of the following options below:

#1 Support Bar

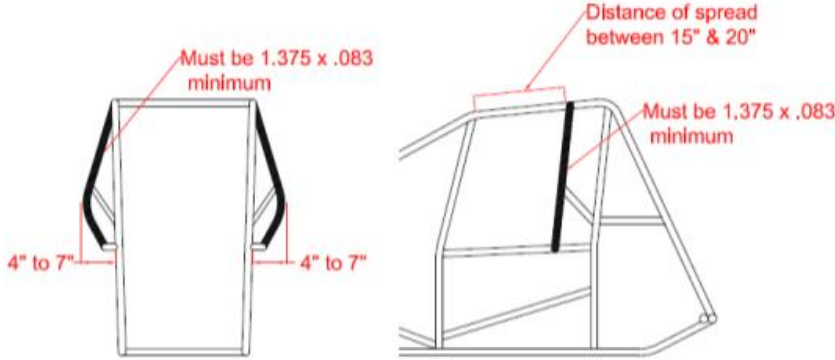

Diagram 16.12.1
By Tom Devitt

#2 Support Bar

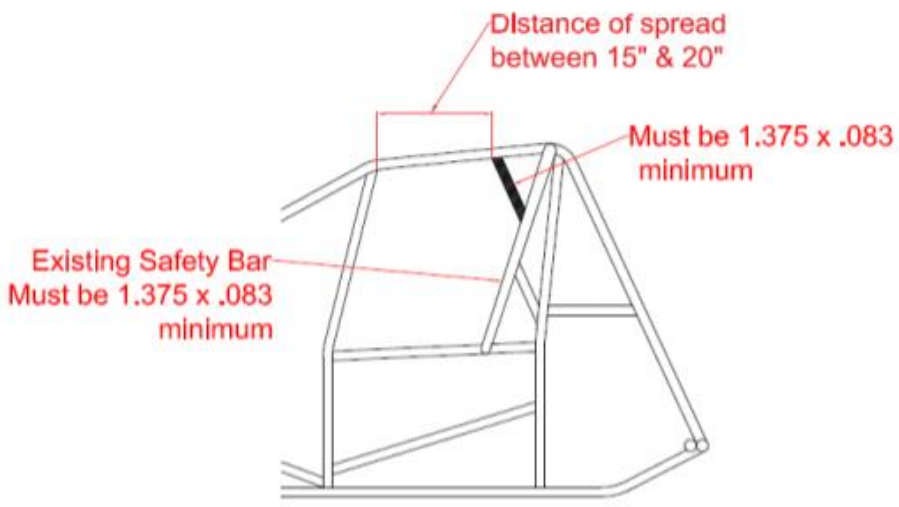
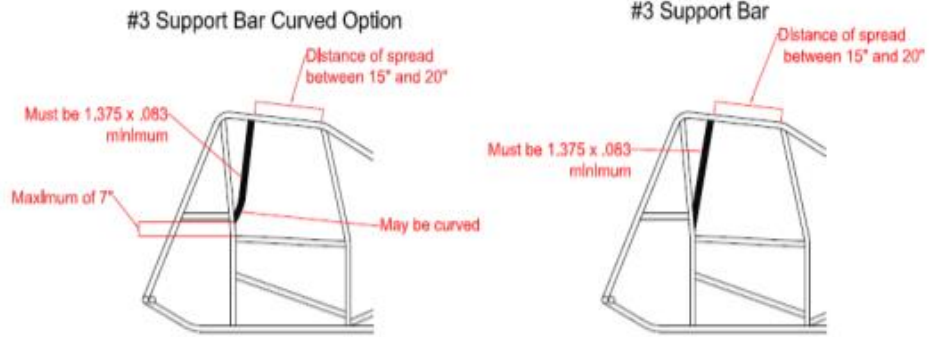

Diagram 16.12.2
by Tom Devitt



Drawing 16.12.3
By Tom Devitt

NOTE - An energy absorbing roof (Part Number 5010015) MAY be allowed in all Renegade Traditional Series including High Roller in 2024. IF SO than the EA roof must be mounted according to the Renegades body template. (not available yet) A minimum 18" opening must exist in front of the energy absorbing roof. The energy absorbing roof must be mounted with a minimum of 8 - 5/32" rivets to each side panel. The energy absorbing roof must be installed with a maximum 12-degree angle from top surface to ground, measured with driver, before or after an event. More information will be available in the coming months. **They are NOT allowed at this time pending more testing, availability and price.**

Strongly Recommended Equipment

- High impact roll bar padding
- Knee protection
- Fire resistant “Impact Dissipating Race Seat Padding,” “Crash Pad,” or a “Visco-Elastic Polymer Padding” product for race seats that is designed to distribute impact forces. Impact dissipating seat padding should not cover the entire seat, and should not have a thickness that exceeds 1/2 of an inch.
- Head and neck restraint
- On-board fire suppressant system

It is strongly recommended that seat belts be replaced every season.

It is strongly recommended that the driver can enter and exit the left side of the car.

Any safety or fire safety gear should be in good condition and serviced annually or as needed.

Unsafe Cars

Any car thought to be unsafe by NRSS or track officials will not be allowed to participate.

4-Wheelers

In Pits: All 4-wheelers, gators, etc. should either be in your pit stall or behind your car at all times.

No running around the pits.

All 4-wheelers, gators, and vehicles used to push a sprint car shall have a pusher plate constructed in such a way so as to prevent the 4-wheeler, gator, or push vehicle from getting hooked on, over, or under a sprint car rear bumper. All 4-wheelers, gators, and push vehicles are required to have a charged, and readily accessible, fire extinguisher suitable for methanol and oil fires. All push vehicles should be large enough (engine size cc) and mechanically maintained in order to enter the track. If push vehicle is not capable of starting a sprint car, make arrangements with NRSS officials.

During Races: All teams that have 4-wheelers, gators, or push vehicles, may be asked to push off their own sprint car prior to the start of each race and after red flag periods. After a red flag, if teams are pushing off their own car, the team’s push vehicles will not be allowed on the track until instructed to do so. No 4-wheelers, gators, and push vehicles will be allowed on the race surface or in the infield at any other time. The location of a designated area for 4-wheelers, gators, and push vehicles to park during the race will be announced at the drivers’ meeting. Note: No 4-wheelers, gators, or push vehicles will be allowed behind a sprint car until a red flag situation changes to yellow, and the push-off process begins.

Some tracks may have special procedures for 4-wheelers, gators, and push vehicles. This information will be communicated at the drivers’ meeting. It is the driver’s responsibility to pay attention, and ensure team members comply with the rules.

ORDER OF EVENTS

Heat In Engines

Drivers are required to wear full safety gear when putting heat in their engines. Failure to do so will result in starting last in each race for the event. **Push starts allowed in designated areas only!**

Time Limits

Each race will have a one minute per lap rule (e.g., a 25-lap race must be completed within 25 minutes). This rule will be enforced within reason.

Push-Off Lane

All cars must be in the designated push-off lane, or en route to the push-off lane, when the first car is pushed off to start any event. Cars not in, or en route to, the push-off lane, will start the race at the back of the field. **Push starts allowed in designated areas only!**

Packing

All drivers must participate in track packing when requested. Failure to pack the track when requested will result in those teams not participating in their heat race and starting at the back of the feature. **Failure to get your car out for packing on-time may result in being put to the back of the feature line-up.**

Hot Laps

Drivers are not allowed to hot lap while push trucks, officials, or safety crews are on the race surface. When a driver is pushed off for hot laps, the driver must wait until the race surface is clear and the light goes green before hot lapping.

DO NOT try to hot lap under a yellow condition. Hot lapping under anything other than a green light is a critical safety issue! A driver can be black flagged and penalized for hot lapping under a yellow condition. When a track is yellow, officials may be on the race surface, in push trucks, or in safety vehicles on the race surface.

There is absolutely no reason for a driver to endanger the lives or wellbeing of officials or track workers who are there to help the competitors.

RACE PROCEDURES

Heat Races

- Heat races will be held at most events.
- Each heat race will have a maximum of 10 cars.
- The car count at the close of the drawing for heat races will determine the number of races to be run (10 or less cars = 1 race, 11-20 cars = 2 races, 21-30 cars = 3 races, 31-40 cars = 4 races) **Subject to promoter demand**
- Heat races will be a minimum of 8 laps.

- Each competitor will draw for a heat race start position. As each driver draws a number, that number will be posted. This procedure will be repeated until a number has been drawn for each driver that wishes to compete. The lowest number goes to the pole of the first heat race, the next lowest drawn number goes to the pole of the second heat race, and so on. Once the pole positions in each race have been filled, the next lowest number goes to the outside front row of the first heat race, and so on. If there is an uneven number of cars to equally distribute between races, the last cars will be placed at the back of the lowest numbered races. Any driver not represented at the drawing shall start at the back of the field. Rookies will start at the back of the field for a minimum of three events.
- Time trials may be used at some events.
- Passing points may be used at some events. Passing points earned from the heat race, in accordance with the NRSS passing point chart, will be used to determine the starting lineup for the B-Main and feature race. Rookies that are required to start at the back of the field will also start at the back of the field for the B-Main or feature race, regardless of how many passing points were earned in the heat race. The eight drivers earning the most passing points out of the heat races may redraw for the top eight starting positions in the feature race. In some cases, there may be an invert of 0, 2, 4, 6, or 8 for the feature race. The remainder of the field will line up behind the top eight heat finishers based on passing points earned. All drivers not qualifying for a position in the feature race will be lined up in a B-Main race based on passing points earned.

B-Main

- One or more B-Main races may be held at events with total car counts of 21 or more, unless the promoter chooses to start all cars.
- Each B-Main race will have a maximum of 20 cars.
- The total car count for the event will determine the number of B-Main races to be held. A single B-Main race may be held if less than 20 drivers do not qualify for the feature race. Two B-Main races may be held if more than 20 drivers fail to qualify for the feature race.
- B-Main races will be a minimum of 12 laps.
- All rookies that are required to start at the back of a field, will start at the back of the field if they successfully transfer into the feature race.

Feature Race (sometimes referred to as the A-Main race)

- The feature race will be the final race at each event.
- Each feature race will have a maximum of 24 cars. The promoter may choose to add additional cars if track conditions are such that additional cars can be safely accommodated.
- Each feature race will be a minimum of 20 laps. (15 Laps for 10 or less cars)
- The top eight drivers out of the heat races will redraw for the top eight starting positions in the feature race. In some cases, there may be an invert of 0, 2, 4, 6, or 8 for the feature race. All other drivers will line up behind the top eight heat finishers in accordance with passing points earned or if pass points are not used, straight up from heat race finishes. Rookies will start at the back of the field for a minimum of three events.
- When calculating starting positions for the feature race, it is possible for drivers to have the same passing point total. All ties will be broken in the following manner:

- If both drivers were in the same heat race, the driver with the highest finishing position in that race will be awarded the higher starting position in the feature race.
- If the drivers were not in the same heat race, the higher starting position will go to the driver that ran in the first heat race.

The NRSS reserves the right to change the format of events, at will, and with no prior notice. The goal will be to announce all changes to the format at the drivers' meeting.

POINT CHART

UMSS passing point chart																	
Start position																	
	1	2	3	4	5	6	7	8	9	10	11	12	13	14	15	16	
	1	128	133	138	143	148	153	158	163	168	173	178	183	188	193	198	203
F	2	119.5	121	126	131	136	141	146	151	156	161	166	171	176	181	186	191
i	3	111	112.5	114	119	124	129	134	139	144	149	154	159	164	169	174	179
n	4	102.5	104	105.5	107	112	117	122	127	132	137	142	147	152	157	162	167
i	5	94	95.5	97	98.5	100	105	110	115	120	125	130	135	140	145	150	155
s	6	85.5	87	88.5	90	91.5	93	98	103	108	113	118	123	128	133	138	143
h	7	77	78.5	80	81.5	83	84.5	86	91	96	101	106	111	116	121	126	131
	8	68.5	70	71.5	73	74.5	76	77.5	79	84	89	94	99	104	109	114	119
P	9	66	61.5	61	64.5	66	67.5	69	70.5	72	77	82	87	92	97	102	107
o	10	51.5	53	54.5	56	57.5	59	60.5	62	63.5	65	70	75	80	85	90	95
s	11	43	44.5	46	47.5	49	50.5	52	53.5	55	56.5	58	63	68	73	78	83
i	12	34.5	36	37.5	39	40.5	42	43.5	45	46.5	48	49.5	51	56	61	66	71
t	13	26	27.5	29	30.5	32	33.5	35	36.5	38	39.5	41	42.5	44	49	54	59
i	14	17.5	19	20.5	22	23.5	25	26.5	28	29.5	31	32.5	34	35.5	37	42	47
o	15	9	10.5	12	13.5	15	16.5	18	19.5	21	22.5	24	25.5	27	28.5	30	35
n	16	0.5	2	3.5	5	6.5	8	9.5	11	12.5	14	15.5	17	18.5	20	21.5	23

EVENT RULES

Changes in Race Lineups - Start/Restart Lineup Corrections

Changes in lineups will be handled in the following manner:

- Prior to initial green flag and one lap being completed:
 - Lineup: Cars will be crisscrossed from the open position on back.
 - Passing point scoring adjustment: Drivers will be scored from the revised lineup positions based on adjusted passing point calculations.

If a driver elects to start at the tail of the field, that driver should report their choice to a NRSS official prior to the start of the race so a proper lineup can be determined ahead of time. Passing points will be assigned from that driver's scheduled starting spot.

Alternates will only be allowed for the feature race. If a driver fails to start for a feature race, the rows behind that driver will crisscross to fill the vacancy, and the alternate starts on the last row, either inside or outside, depending on where the scratched driver was to start. Once the initial green flag is waved, even if a lap is not completed, the field will be deemed to be complete and no alternate will be added to replace damaged cars.

When the field gets the one-lap-to-go flag, and passes the flag stand, the driver on the pole position will set the pace for the start of the race. **No throttle-pumping, pulling out of line or brake-checking will be allowed after this point.** The leaders will bring the field to a designated spot (cone and white line) exiting the fourth turn on the track at a moderate pace. The field will maintain a side-by-side, nose-to-tail posture. The driver in the pole position sets the pace, and starts the race at the designated point. If the pole car is not maintaining an appropriate pace, the driver will be notified on the Raceceiver radio. Failure to pick up or maintain a proper pace can result in a penalty if NRSS officials deem the pace unsafe and warnings to maintain a proper pace are ignored. **A jumped start will result in 1 warning, a second will result in being docked 2 spots.** If a driver **pulls out of line before a start, that driver will be penalized two spots at the next yellow, red or at the end of the race,** whichever comes first.

Side-By-Side Starts

In an effort to give NRSS race fans the best show possible, and to give each NRSS driver the opportunity to compete on a level playing field, the following race start and restart procedures will be enforced.

- Initial race starts, and restarts, will be done in rows of two.
- The pole car (inside row 1) sets the pace. Pace should be consistently maintained down the back straight and through turns 3 & 4, until the green flag and/or green light is displayed.
- The pole car shall allow sufficient room for the outside row alongside the pole car. A consistent line through turns 3 & 4 shall be maintained by the pole car on the bottom half of the track so as to allow plenty of room for the outside row of cars in order to facilitate a safe start.
- If a driver in the pole position fails to leave sufficient room for the outside row, and/or does not hold a consistent line through turns 3 & 4, **the driver will be penalized for jumping the start.**
- The outside row must maintain a side-by-side position with the inside row until the race starts.
- Rows 2 through the end of the field should **follow front row cars nose-to-tail.**
- The driver in the outside front row position shall not go across the start line prior to the pole car and will be no farther back than half a car length from the pole car.
- The start line is defined by the white line across the track in turn 4 with a cone on the inside of the line.
- The driver in the pole position is allowed to fire and start the race at any time within **20** feet before the line. The race starts when the driver in the pole position fires, or when the pole driver's front tires cross the white line.

Jumping Starts and Restarts

The initial start will be green-flagged at the line in the fourth turn. On the race's initial start, if the drivers on the front row can't work together and get an even start, one or both offenders will be penalized. If a driver further back gets out of the line (not side-by-side and/or nose-to-tail) as the front row accelerates, it will be considered a jump. Penalized driver will be moved back two positions at the next flag.

NRSS utilizes the “Delaware” Double File restart alignment during the entire race unless there are less than 5 laps to go or single file is deemed necessary by the NRSS Race Director. Leader takes the front row as a single car, second place must chose the inside or outside of row 2 and clearly position his car to indicate his/her choice when prompted by the officials during the realignment. Third place takes the open spot next to second place in row 2. Forth place goes inside row 3, fifth place goes outside row 3 and so on until all positions are filled.

During a restart, the lead driver must start at the fourth turn cone or chalk line. Starting more than 20 feet before the cone or chalk line in the fourth corner can result in a two-position penalty. Again, the penalty may be assessed at the first yellow or red flag, at the end of the race, whichever comes first or may be called back immediately. Only one warning per race.

Scoring

The entire field normally has to complete a lap before a single file restart occurs. If, after three attempts to start a race double file fail, a single file start may be used. When a yellow or red flag is waved, scoring terminates and the restart lineup will be based on the last lap the entire field completed. Cars involved in an incident will be put to the rear of the field. The NRSS uses Raceceiver radios and drivers are expected to use them for directions regarding positioning from the tower. A penalty may be issued for failure to respond to Raceceiver communications. Any car lapped by the lead car will be considered a lap down to all cars on the lead lap.

Lining up for Restarts

When the yellow flag is waved, drivers are to line up behind the car directly to their front, whether it is lapped or not, and form a single file line, nose-to-tail. Officials will correct the lineup when they receive it from the official scorers. Drivers who fail to line up, or do not go to an assigned spot when told to do so by officials, will be sent to the tail of the field or will be disqualified. Lapped cars will go to the tail of the field. Lapped cars will then be scored on the same lap as the leaders.

Two Yellow (Spin) Rule

Any driver who causes two yellows in any race will be black flagged from the race. The driver will bring their car to the pit area, and will not restart. Any driver involved in more than three race stopping incidents of any combination, assisted or unassisted, will be black flagged.

No Repairs on Track

A driver or crew member may not work on a car while on the race surface. NRSS officials can and will inspect a race car for safety issues, and will decide if a car should go to the designated work area (feature only) or the pits. No touching or adjusting the cars under a Red Flag.

Flat Tires

If a driver experiences a left front flat tire, the driver will be allowed to continue racing. Any driver experiencing a flat tire, other than the left front tire, during a heat race will be black flagged. A driver experiencing a flat tire, other than the left front tire, during a B-Main or feature race will go to the designated work area and will be given two laps, once the lineup has been set, to change the tire.

Work Area

If a driver experiences a flat tire or mechanical failure on their race car during a feature race, the driver may go to the designated work area using the safest means possible. A yellow flag will come out, if it has not already, and the driver's pit crew will be granted two laps, after the rest of the field is in their correct order and lined up for a restart, to get the driver's car race ready. The designated work area is located off the race surface. Pit crew personnel are not allowed to work on a car until it is in the work area. If work begins before a car is in the work area, the driver will be disqualified. Furthermore, a driver's race car must appear safe for restarting in the opinion of NRSS and track officials before a race car will be allowed to restart the race. If a driver's pit crew cannot complete repairs in the time allotted, the driver will not be allowed to restart, will be removed from the designated work area, and will be scored in accordance with the number of laps completed. If a driver experiences a flat tire or mechanical failure on their race car in anything other than a feature race, the driver must leave the race surface using the safest means possible, and the driver will be scored in accordance with the number of laps completed. The designated work area may be closed at the NRSS official's discretion at any time if a curfew, time, weather, or other factor threatens the timely completion of the feature race.

Incomplete Race

In an event where the feature race cannot be completed due to weather, time, or other factors, the payoff will be paid based on the finishing order of the last completed lap. If a race is stopped due to weather, time, or other factors, and cannot be restarted, the race will be declared complete if the race has reached or exceeded the halfway mark. When a feature race is stopped, cannot be restarted, and has not reached the halfway mark, NRSS and track officials may declare the race complete if the feature race is close to the halfway mark and no rain date was scheduled.

If a feature race was not started or completed, due to weather, time, or other factors, and a rain date was not scheduled, the following procedures will be followed:

- If heat races were completed, NRSS officials will work with the host track to determine equitable compensation or a refund of pit passes.

Driver Changes

No driver changes will be allowed after the start of the heat races. A driver may qualify and race only one car. A driver change can take place after hot laps and prior to the start of the heat races.

Late Arriving Entrants

If a driver misses the heat race for any reason, the driver will be allowed to start the feature race at the back of the field. If there are enough drivers for a B-Main, all drivers not placing in a heat race will start at the back of the B-Main field.

Engine Changes

Engine changes are allowed after hot laps with no change in starting position in the heat race. If an engine change occurs after a heat race, that driver will start at the back of the field in the feature race. If there are enough drivers for a B-Main, all drivers that change engines after their heat race will start at the back of the field of the B-Main.

Backup Cars

Backup cars that bear the same number can be brought out prior to the heat races. Only one car may be used for multi-day events that qualify a car on the first night to subsequent nights. In other words, if a second car is used on the second night of a multi-day event, the qualifying spot for the original car is disqualified and the qualifying spot for the second car must be used. This rule applies to multi-day shows whether held at the same track or multiple venues.

Scale

Immediately after each race, and before going to the race car trailer staging area, the top three to five finishers in the heats and feature races must go to the scale. If a driver fails to scale, the driver will be disqualified, and will not receive any payout or points for that race. Any change to this procedure will be announced at the drivers' meeting. If in doubt, scale! In addition, no crew member will be allowed to work on (touch) the car before scaling and going to tech. This includes the winning car in Victory Lane.

Tech

Immediately following the finish of an A-Main feature race, the top three to five finishers must move their race cars to the designated tech area immediately after scaling their car. A failure to report to tech, stopping at the race car trailer staging area before reporting to tech, or attempting to alter the race car in any way, will result in immediate disqualification. Any car that fails a technical inspection will be disqualified and will receive no money for the night. In addition, any team that refuses tech or ends tech before it is completed will be disqualified. Doing this twice will result in disqualification for the night, a 4-race penalty and a \$300 fine. Subsequent refusals will result in a one-year penalty and up to a \$2,500 fine. The NRSS Technical Officials will have complete control of all tech inspection activities. Decisions of NRSS officials are final. No more than one crew member and one driver are allowed in the designated tech area until all tech inspections have been completed. Any driver having any more than one representative from their team in the tech area before tech has been completed will be immediately disqualified. A head count will be performed before the technical inspection begins.

ENGINE PROTEST RULE

Application

The engine protest rule is applicable to all drivers at all NRSS events.

Race Cars Subject to Being Protested

All race cars competing in a NRSS feature event.

Drivers Eligible to Protest

All NRSS licensed drivers competing in a NRSS feature event are eligible to protest any race car engine used to compete in a NRSS event. All protests must be executed with a NRSS Technical Official prior to the start of the feature race. A protest fee of \$300.00 (in U.S. cash currency only) must be tendered to execute a protest.

Disposition of Protest Fee

If, after tear down, the protested engine is found to be legal, \$250.00 of the protest fee will be paid to the protested driver, and \$50.00 will be paid to the NRSS Technical Official. If the protested engine is found to be illegal, \$250.00 of the protest fee will be returned to the protesting driver, and \$50.00 will be paid to the NRSS Technical Official.

Protest Procedure

After the feature race, a NRSS Technical Official will notify the driver that their race car engine is subject to a protest. The protested driver will schedule a teardown procedure with the NRSS Technical Official. The teardown procedure may take place at the track, or other suitable location, within a reasonable period of time.

Special Provisions Related to Protests

- A licensed NRSS driver is the only participant that may protest.
- **A driver may not protest an engine in their first season of competition.**
- A driver may only protest one engine per race.
- The NRSS Technical Official has the final word on the legality of the engine involved in a protest.
- No person shall prevent or interfere with the protest procedure.

Withdrawal of Protest

If a driver declares an intent to protest, and tenders the required protest fee, the protest procedure must be executed. If a driver attempts to rescind or cancel a protest, the driver will lose the protest fee, will forfeit all money and awards for the event.

Refusal of Protest

A driver who refuses to allow a tear down procedure pursuant to a protest shall be subject to a one-year suspension, a \$2,500 fine, and must repay all winnings earned in the current season.

No engine can be protested more than once per season. The NRSS may perform an engine teardown procedure at any time.

FLAGS

Green

When the green flag waves, it constitutes the beginning of a race, even if the initial lap is not completed.

Black

Leave the race surface and pull off the race track without causing a yellow, and as safely as possible. A black flag may indicate something is wrong with a car and is jeopardizing the safety of participants. Failing to acknowledge a black flag is an automatic disqualification.

Yellow

Reduce speed, proceed with caution, and do not pass. Drivers are to form a single file, nose-to-tail, and await the restart lineup. Scoring stops under yellow conditions. There is no racing back to the start/finish line allowed.

Note: Any driver that stops their race car during a yellow flag condition **may** be placed at the rear of the field, even if the driver was not involved in an incident **IF it is unable to be determined they were not initially involved. NRSS does NOT make judgment calls so if the racer was not SEEN to be clearly ONLY stopping to avoid, they will be going to the back. This is a change to help drivers make the SAFEST decision during a crash. Please respect that we will likely not always get this right.** If contact is made, and the driver's car comes to a stop because of it, the driver is considered involved.

Red

The race is stopped. Drivers are to slow down and stop as quickly and safely as possible. Drivers are not to drive through a red flag crash scene. Doing so will result in a penalty.

During red flag conditions, drivers are to stop their car on the upper half of the racetrack to leave the bottom lane clear for emergency vehicles. This also leaves a lane open to push off race cars when the track returns to yellow.

All red flag conditions are considered closed unless otherwise designated. Working on a race car during a red condition is not allowed. If NRSS officials decide to open up a red flag, drivers will be notified via the Raceceiver radio, and crews will be given the proper instructions on what can be done to the car (for example, fuel and tear-offs only).

Blue

Hold a steady predictable line. Faster cars are approaching.

White

The white flag tells a driver there is one lap to go before the completion of a race. If a yellow or red flag occurs on the last lap, the restart will be a green-white-checkered finish.

Checkedred

The race is finished.

Yellow/Checkedred (both)

An incident has occurred on the track after the checkedred has been shown to the leader or already waved. The drivers crossing the line prior to the yellow flag condition will be scored as finished. The remainder of the field will be scored from the previous lap. Drivers involved in the incident will be scored at the rear of the field on the last scored lap. Weather, time, track conditions or other factors can also cause a yellow/checkedred.

Red/Checkedred (both)

Same as yellow/checkedred; however, the incident is more severe and cars need to stop immediately and follow the normal "closed" red flag procedures. The race is over if a red/checkedred flag comes out.

Traditional Sprint Specifications

Engine Specifications

There are three engines that are legal in this series. All engines are subject to pumping, whistling, and/or tear down by officials at any time.

360 Engine

1. Block

- Any Chevrolet 305, 307, 327, or 350 CI stock iron block that was available in a passenger car or truck. Max overbore - .060"
- Any Ford 302 or 351 Windsor stock iron block that was available in a passenger car or truck. Max overbore - .060" No Cleveland, M, or "Clevor" engines allowed.
- Any Chrysler 318, 340, or 360 CI stock iron block that was available in a passenger car or truck. Max overbore – 318 and 360 - .040". 340 - .060"
- No interchange of crankshafts or rods to blocks allowed.
- Absolutely no lightening of any kind is allowed. All mounts must remain, fuel pump, motor etc.
- Factory 2 or 4 bolt main blocks ONLY (can NOT alter a 2-bolt block to a 4-bolt block). No splayed caps.

2. Crankshaft

- Any stock GM production crankshaft allowed.
- The following Scat 9000 Series crankshafts are allowed:
 - Chevrolet 350 - Scat (Part # 9-10442)
 - Ford 351 - Scat (Part # 9-351-3500-5955-2311)
 - Chrysler 340,360 - Scat (Part #s 9-340-3580-6123, 9-360-3580-6123)
- The following Eagle OEM replacement crankshafts are allowed:
 - 103503480
 - 103503480CM
 - 103523480
- The crankshaft stroke must match the block.
- No lightening, counterweight knife edging, or counterweight polishing allowed. Balancing is allowed.
- Crankshaft flange may be machined to fit rear motor plate and torque ball housing.
- Any crankshaft or connecting rod with a part number superseded by the manufacturer is legal as long as the crankshaft or connecting rod with a superseded part number has the same specifications as the legal crankshaft or connecting rod.

3. Connecting Rods

- Any stock steel production connecting rod, Scat OEM replacement I-Beam (must say Scat 5.7), Eagle OEM I-Beam PN SIR5700BBLW, or Eagle OEM I-Beam PN SIR5700BPLW is allowed

- Chevrolet 5.7" length powdered metal connecting rods are allowed.
- The connecting rod length must match the block.
- No grinding or polishing allowed. Connecting rod balance pads may be machined to balance rotating and reciprocating mass. One big end and one small end balance pad must remain stock.
- No cap screws allowed except on designated Eagle OEM rod. Max 3/8" bolts.

4. Pistons

- Any forged, cast, or hypereutectic aluminum piston is allowed.
- Engines must not exceed 9.50:10 compression ratio. No exceptions!

5. Camshaft

- Camshafts and lifters must be hydraulic.
- Lifters must collapse a minimum of .100".
- Only lifters of engine make can be used.
- Lifters must rotate freely and be of magnetic material.
- The camshaft must be driven by a timing chain. No belt or gear drives are allowed.
- The camshaft may be drilled for a rear spud.
- No lightening, grinding or polishing is allowed.

6. Cylinder Heads

- The cylinder head must be a stock cast iron production head. No aftermarket heads are allowed.
- Chevrolet 1987-1995 Swirl Port heads are allowed.
- Ford 302 GTP heads are allowed for both the 302 & 351W.
- No Vortex, Bowtie, SVO, W-2, Magnum, Gen II, or angle plug heads are allowed.
- The following Chevrolet casting numbers are not allowed: 040, 041, 186, 187, 291, 370, 414, 432, 461, 461X, 462, 492, 10125320, 10208890, 10239906, 12554290, 14011083, or 14096217.
- Porting or polishing of any kind is not allowed.
- Angle milled cylinder heads are not allowed.
- Carbide cutter relief cuts are allowed below the valve seat, but are not to exceed more than ¼ inch below the top of the valve seat. A small deviation in this specification is allowed due to manufacturing variations in the area below the valve seat area.
- Valve springs must be the same diameter of a stock production spring. Tapered or Beehive valve springs are not allowed.
- Steel stock type stamped rocker arms only. Roller or roller tipped rocker arms are not allowed.
- Stud girdles are not allowed.

7. Intake Manifolds

- The following intake manifolds are the only intakes allowed.
 - Chevrolet - Weiand (Part # 7546, 7467, or 7547-1 X-CEerator).
 - Ford – Weiand (Part # 7515, 8023), Professional Products (Part # 54033).
 - Chrysler - Weiand (Part # 7545).

- Porting, polishing, or gasket matching of any kind on an intake manifold is not allowed.

8. Oiling System

- Wet sump only. The oil pump must be in the oil pan.
- A 3/4-inch inspection hole (1 inch highly recommended) must be installed in the side of the oil pan 2 ½ inches down from the pan rail and in line with a journal. Removal of the oil pan may be required if further inspection is necessary.

9. Ignition, Starter & Electronics

- All battery-powered ignitions and magnetos are allowed, except where noted. A magneto is highly recommended. External coils are allowed.
- No MSD type magnetos are allowed.
- Aftermarket crank triggers are not allowed.
- Cars must have a clearly marked ON/OFF switch within reach of the driver and visible to officials.
- Only one battery is allowed. **The battery must be securely hard mounted and shielded.**
- An on-board starter is allowed.
- No electronic monitoring devices capable of storing or transmitting information are allowed, except for a memory tachometer.
- No electronic traction control devices are allowed.
- All engines are required to use a stock firing order.

10. Exhaust

- Any sprint car type header is allowed, except where noted.
- One collector per side. Slip or merge type headers are not allowed. Mufflers are optional.
- Race cars may be required to have a muffler if local track rules require mufflers.
- Schoenfeld part number 112535, 112530, or Knoxville 14272735-78 are mandatory for all tracks that require the use of a muffler.
- No Tri Y headers.

11. Water Pump & Radiator

- Any stock type water pump is allowed.
- The radiator must be mounted in front of the engine.

12. Carburetor

- A minimum of two return springs must be connected to the throttle.
- The throttle pedal must have a toe strap.
- A Holley #4412 series 500 CFM 2 bbl carburetor is the only carburetor allowed.
- The Holley HP and XP are not allowed.
- Aftermarket metering blocks are allowed.
- Carburetor main body must be originally manufactured with an integrated OEM choke tower.
- Material may be removed from the choke.
- A NRSS go/no-go gauge will be used to determine carburetor legality.

- Any carburetor spacer is allowed. **NOTE: After the rule freeze is over (2027) the “super bowl” carburetors will likely not be allowed.**

13. Fuel

- Racing alcohol is the only fuel allowed. The use of gasoline is strictly forbidden.
- No nitro or nitrous oxide is allowed.
- No oxygenated fuel additives are allowed. Fuel is subject to inspection at any time.

14. Fuel Pump

- Mechanical, belt driven, and cam driven fuel pumps are allowed. A cam driven fuel pump is highly recommended.
- Electric fuel pumps are not allowed.

5.3L LS Engine

1. Block

- Factory production iron blocks are the only blocks allowed. Aluminum blocks are not allowed. Aftermarket and bow-tie blocks are not allowed.
- Only industry standard reconditioning of the factory production iron block is allowed.
- Boring, honing, line honing deck resurfacing, and lifter bore repair is allowed.
- The cylinder bores may be resized a maximum of .060” over stock.
- Absolutely no lightening of any kind. All mounts must remain. Grinding or defacing of any factory numbers or markings of any kind is not allowed and will result in disqualification.
- Oversized and roller cam bearings are not allowed.

2. Crankshaft

- A stock OEM Chevy crankshaft with a stroke length of 3.622” is the only crankshaft allowed.
- No lightening, counterweight knife edging, or counterweight polishing is allowed. Balancing is allowed.
- Crankshaft flange may be machined to fit rear motor plate and torque ball housing.
- 24 and 58 tooth reluctor wheels are allowed. Make sure your MSD box is the correct one for your reluctor wheel before ordering.

3. Connecting Rods

- Chevrolet OEM powdered metal connecting rods with a 6.098” center to center length are the only connecting rods allowed.
- Connecting rod bolts may be replaced. Small ends may be bushed and fitted for floating pins. Big ends may be resized to factory specs.
- No deburring or polishing is allowed. Connecting rod balance pads may be machined to balance rotating and reciprocating mass. One big end and one small end balance pad must remain stock.

4. Pistons

- Any forged, cast, or hypereutectic aluminum piston is allowed.
- Engines must not exceed 9.50:10 compression ratio. No exceptions!

5. Cam/Lifters

- Only stock GM part number lifters are allowed as a replacement.
- Stock or stock style replacement rocker arms only. Roller tip rockers are not allowed.
- Rocker arm trunnions may be upgraded to allow more lift if needed. No other rocker arm modifications are allowed.
- The push rods must be stock or 5/16" stock replacement style push rods.
- The maximum allowable lift at the valve is .600".
- The camshaft may be drilled for a rear spud.
- No lightening, grinding or polishing is allowed.

6. Cylinder Heads

- Factory aluminum cylinder heads only. The casting number must end in 862 or 706. All other cylinder heads are illegal and will result in disqualification.
- Only industry standard head reconditioning is allowed. Valves may be replaced, but the replacement valves must have a stock stem diameter, stock length, and a stock head diameter (1.89" intake, 1.55" exhaust). Seats and guides may be replaced.
- Carbide cutter relief cuts are allowed below the valve seat, but are not to exceed more than ¼ inch below the top of the valve seat. A small deviation in this specification is allowed due to manufacturing variations in the area below the valve seat area.
- Angle milling of the head, intake, or exhaust surfaces is not allowed.
- No porting, grinding or polishing of any kind is allowed.
- A stock style single Beehive valve spring is the only valve spring allowed.

7. Intake Manifolds

- All 5.3 LS engines must use the Edelbrock Victor Jr. part number 29087 intake or Holley 300 – 132 single plane.
- No modifications to the intake manifold are allowed.
- No porting, polishing, or grinding of any kind is allowed.

8. Oiling System

- Wet sump only. The oil pump must be in oil pan.
- A 3/4-inch inspection hole (1 inch highly recommended) must be installed in the side of the oil pan 2 ½ inches down from the pan rail and in line with a journal. Removal of the oil pan may be required if further inspection is necessary.

9. Ignition, Starter & Electronics

- The MSD #6010, MSD #6014, MSD #6014CT and MSD #60143 ignition controllers are the ONLY controllers allowed.
- Stock or stock replacement coil packs are allowed.
- No performance coil packs are allowed (i.e., Accel, MSD, etc.).
- At this time, no rev limit restrictions will be imposed, but NRSS reserves the right to change this in order to ensure engine parity.

- Cars must have a clearly marked ON/OFF switch within reach of the driver and visible to officials.
- Only one battery is allowed. **The battery must be securely hard mounted and shielded.**
- An on-board starter is allowed.
- No electronic monitoring devices capable of storing or transmitting information are allowed, except for a memory tachometer.
- No electronic traction control devices are allowed.
- The firing order must remain stock.

10. Exhaust

- Any sprint car type header is allowed, except where noted.
- One collector per side. Slip or merge type headers are not allowed. Mufflers are optional.
- Race cars may be required to have a muffler if local track rules require mufflers.
- Schoenfeld part number 112535, 112530, or Knoxville 14272735-78 are mandatory for all tracks that require the use of a muffler.
- No Tri Y headers.

11. Water Pump & Radiator

- Any stock type (LS or small block) water pump is allowed.
- The radiator must be mounted in front of the engine.

12. Carburetor

- A minimum of two return springs must be connected to the throttle.
- The throttle pedal must have a toe strap.
- A Holley #4412 series 500 CFM 2 bbl carburetor is the only carburetor allowed.
- The Holley HP and XP are not allowed.
- Aftermarket metering blocks are allowed.
- Carburetor main body must be originally manufactured with an integrated OEM choke tower.
- Material may be removed from the choke.
- A NRSS go/no-go gauge will be used to determine carburetor legality.
- Any carburetor spacer is allowed.

NOTE: After the rule freeze is over (2027) the "super bowl" carburetors will likely not be allowed.

13. Fuel

- Racing alcohol is the only fuel allowed. The use of gasoline is strictly forbidden.
- No nitro or nitrous oxide is allowed.
- No oxygenated fuel additives are allowed. Fuel is subject to inspection at any time.

14. Fuel Pump

- Mechanical, belt driven, and cam driven fuel pumps are allowed. A cam driven fuel pump is highly recommended.
- Electric fuel pumps are not allowed.

GM 602 Sealed Engine

A sealed GM 602 engine is legal. See the NRSS Technical Director for guidance on competing with the GM 602. The engine must have factory GM seals and all other rules must be followed.

Engine

Engines will be randomly inspected for legality during the season. There will be an opportunity to have your engine whistled before the season. In 2024 we will be checking compression ratio of feature winning cars at various points during the season among other items. If an engine is found to be non-conforming, the driver will be disqualified for one year, fined \$2,500, and must return all prize money earned during the current season.

Contact the NRSS Technical Director if you have any questions.

Dyno Rule

At the discretion of NRSS Technical Officials, any team may be required to dyno their engine at Perfect Performance. The dyno session will be at the series expense and must be completed within two weeks of the request. The engine will be sealed until that time. This will be done in lieu of tearing an engine down initially to determine legality. Tear down may follow depending on results.

Car Construction & Chassis Specifications

Chassis

- Open to any sprint car chassis 1994 to present.
- 4130 chrome-moly, tig welded steel frame recommended. (1 ½ inch diameter by .095 minimum tube thickness on main frame and cage required.)
- Wheelbase: Minimum – 84 inches. Maximum – 96 inches.
- No hollow or drilled bolts, fasteners or Heim joints allowed.

Body

- Conventional sprint car body only. Must be well maintained.
- Must have at least one number of contrasting colors on each side of tail tank and on the front nosepiece. Minimum of 15" tall.
- Hood can be a multiple piece design and must appear to be one continuous piece.
- Conventional side panels only.
- No aerodynamic devices or wings allowed.
- Sun visors are limited to nine inches long and cannot be wider than the cage.
- Solid metal firewall required between the engine and the driver. Fiberglass dash is allowed.
- Solid metal floor pan must extend from the firewall to the front of the driver's seat.
- The body must have a traditional sprint car appearance (minimum window opening on right side approximately 7" tall x 15" wide). A-pillar (body connecting the front of the front of the window opening) is NOT allowed.

Suspension & Steering

All shocks must be constructed of aluminum or steel. No cockpit adjustable shocks or other suspension components allowed. No remote or external canister type shocks allowed. One shock per wheel. May be rebound or compression adjustable on the shock only. No double adjustable shocks allowed. Gas shocks, single adjustable, or nonadjustable are allowed. Front shock protectors are allowed. (Note- gas shocks make the car harder to feel- not easier. Don't be fooled with fancy shocks. You need good shocks, not expensive ones) **NOTE: After the rule freeze is over (2027) shock rules will be adjusted to limit expense.**

- Any conventional torsion bar or coil-over suspension is allowed. Combining the two is allowed. No anti-sway or zero-roll devices allowed.
- Steel straight front axle only. 53" max width.
- Front axle tethers are required. Tethers must be purchased from a safety manufacturer and installed per their recommendations.
- A quick release steering wheel is mandatory.
- The drag link must be tethered to the frame with nylon webbing of at least 1 inch width.
- Drag links and tie rods must be made of 4130 or magnetic steel.
- Magnetic steel heim joints (tie rod ends) required on drag links, **rear torsion arms** and tie rods.
- This does not affect the Radius rods or Panhard and you may run those as aluminum if you would like.

Driveline

- Quick-change center sections required.
- All drivelines must be broken in the coupler or rear slider.
- Driveline must be fully enclosed and contain no more than one U-joint or CV joint and that joint must be at the front of the driveline. No torque arm drivelines allowed.
- Buckley Yokes are allowed.
- Driveline safety strap or driveline hoop restraint constructed of .065" steel either welded or bolted to the chassis is mandatory.
- Steel or approved aluminum shield covering the flywheel is mandatory when bell housing is inside the cockpit. **NOTE: it is Highly Recommended to use a driveline shield**

Rear-End

- Any conventional quick change rear-end is allowed.
- Maximum 2" offset allowed.

Brakes

- Must have minimum left front and left inboard rear brake system. All brakes must work at the start of the event. Rear brakes must work at all times. Additional rear brake allowed.
- Carbon fiber rotors are not allowed.

Bumpers

- Bumpers and nerf bars must be sprint car type bars, constructed of no less than 1" O.D. and .060" wall thickness, and securely bolted to the chassis.
- Side nerf bars may have a triangular or 4 point configuration and cannot extend outside rear tires.
- The front bumper cannot extend more than 8 inches from the frame or 23 ½ inches from center of front axle to front of front bumper.
- "Battle Bar" type side bar will be required for 2024.

Wheels

- Maximum wheel width: Front 10", Left Rear 15", Right Rear 18".
- Bead locks on all wheels are recommended.
- Bleeders are not allowed.
- Wheel covers are allowed.
- Wheel covers need to be fastened with 1/4" bolts or 5 dzuses.
- Wheel covers must be marked with the car number.
- If you lose a wheel cover, a caution will be called and you will go to the back.

Tires – **Note: tire rule subject to changes from Hoosier Tire**

- Right Rear: Right rear tire can only be used on right rear of car. The following tires may be used: Hoosier 105/16.0-15 MED (Medium) or Hoosier 105/16.0-15 H15 or D15A that has been used in competition. (Maximum allowable tread depth is 0.175". Tread depth is measured in any anti-blister hole in the center of the tread block, pre-race.)
- Left Rear: Hoosier RC1, Hoosier H12, Hoosier SC12-98 or Hoosier D12A. Left rear tire can only be used on left rear of car. (Maximum allowable tread depth is 0.175". Tread depth is measured in any anti-blister hole in the center of the tread block, pre-race.)
- Fronts: Any Hoosier.
- Any "new" tires must be put on before the heat race and that car will only be compensated starting money regardless if they win.
- ***WARNING: DO NOT ALTER TIRES*** Chemical Treatment of Tires: Hoosier Racing Tire and the NRSS strictly forbids any chemical alteration of the tire carcass and/or tread compound such as tire "soaking" or use of tread "softener." Hoosier Racing Tire and the NRSS strictly forbids the physical defacement (removal, altering or covering) of tire sidewall markings in any manner. Failure to comply with this warning could result in premature or catastrophic tire failure and may result in SERIOUS PERSONAL INJURY OR DEATH.
- Absolutely no chemical of any kind may be applied to a tire. This includes tire cleaner. The NRSS reserves the right to confiscate and test any tire at any time. Tires may be tested on a random basis. If your tire is confiscated, your check will be withheld until after testing. Tires may be tested on a random basis at NRSS expense unless the tire is found illegal. NRSS will not reimburse teams for the tire. If found illegal, the team will have all points to that point taken away, penalized \$2,500 and banned for 365 days.

Weight

- Minimum weight is 1,550 lbs., including fully suited driver. **NOTE: There will likely be adjustment to weight or materials allowed on the car after the rules freeze is up. (2027)**
- You can be weighed at any time during the event.
- Any added weight must be in block form or formed to frame, painted white with the car number stamped on it. Weight must be securely bolted and located between the front motor plate to 12 inches behind rear motor plate. No weight can be added, moved, or replaced during yellow or red flag conditions.
- NRSS officials reserve the right to disqualify any car whose weight mounting procedure or location does not satisfy our specifications (see illustration below).

NOTE: No added weight will be allowed in the open area under the seat. It will be allowed only in the open area in front of the firewall per the rule above.

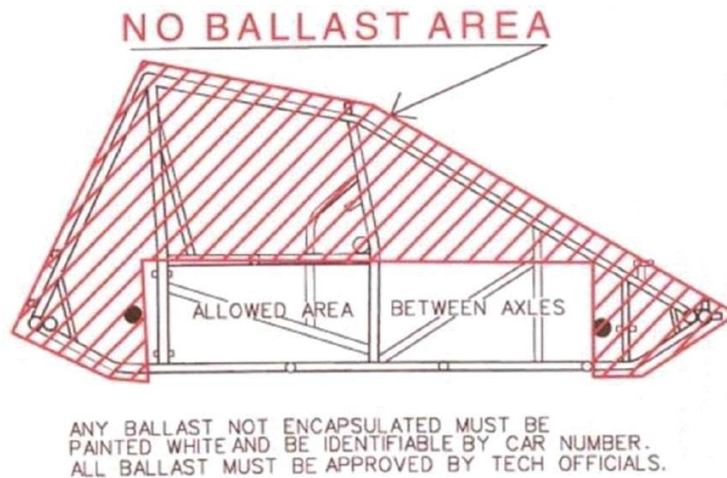

Please keep in mind that we will be correcting any items we deem to be costing the racers too much money after the 2027 season. We will give as much notice as possible to these corrections but every effort will be made to keep this class affordable and fun.

Wing Sprint Specifications

Engine Specifications

There are three engines that are legal in this series. All engines are subject to pumping, whistling, and/or tear down by officials at any time.

360 Engine

1. Block

- Any Chevrolet 350 CI stock iron block that was available in a passenger car or truck is allowed. The maximum overbore allowed is .060”.
- Any Ford 351 Windsor stock iron block that was available in a passenger car or truck is allowed. The maximum overbore allowed is .060”. Cleveland, M, or Clevor engines are not allowed.
- Any Chrysler 340 or 360 CI stock iron block that was available in a passenger car or truck is allowed. Max overbore allowed is .060” for the 340 and .040” for the 360.
- No interchange of crankshafts or rods to blocks is allowed.
- Absolutely no lightening of any kind is allowed. All mounts must remain. This includes fuel pump, motor mounts, and all other stock mounts.
- OEM factory 2 or 4 bolt main blocks are the only blocks allowed. Two bolt blocks cannot be converted to a four-bolt block. Splayed main caps are not allowed.

2. Crankshaft

- Any stock production crankshaft is allowed. Interchanging of crankshafts to blocks is not allowed. The crankshaft stroke must match the block.
- The following aftermarket crankshafts are allowed:
 - Chevrolet 350 – Scat (Part # 9-10442), Eagle (Part #s 103503480, 103503480CM, and 103523480)
 - Ford 351 – Scat (Part # 9-351-3500-5955-2311)
 - Chrysler 340, 360 – Scat (Part #s 9-340-3580-6123, 9-360-3580-6123), Eagle (Part #s 103403310, 103603580)
- No lightening, counterweight knife edging, or counterweight polishing is allowed. Balancing is allowed.
- The crankshaft flange may be machined to fit rear motor plate and torque ball housing.
- Any crankshaft or connecting rod with a part number superseded by the manufacturer is legal as long as the crankshaft or connecting rod with a superseded part number has the same specifications as the legal crankshaft or connecting rod.

3. Connecting Rods

- Any stock OEM steel production connecting rod is allowed.
- The following aftermarket connecting rods are allowed:
 - Chevrolet 350 – Scat OEM replacement I-Beam (must say Scat 5.7), Eagle OEM I-Beam (Part #s SIR5700BBLW, SIR5700BPLW)

- Ford 351 – Eagle I-Beam (Part #s SIR5956FP, SIR5956FB)
- Chrysler 340, 360 – Eagle I-Beam (Part #s SIR6123CP, SIR6123CB)
- Chevrolet 5.7” powdered metal connecting rods are allowed in Chevrolet engines.
- The connecting rod length must match block. Interchanging of connecting rods to blocks is not allowed.
- Grinding or polishing of connecting rod beams is not allowed. Connecting rod balance pads may be machined to balance rotating and reciprocating mass. One big end and one small end balance pad must remain stock.
- Cap screws are not allowed except on designated Eagle OEM rods. The maximum rod bolt diameter is 3/8”.

4. Pistons

- Any forged or cast aluminum piston is allowed. Pistons made of anything other than aluminum is not allowed.
- Engines must not exceed 9.50:10 compression ratio. No exceptions!

5. Camshaft

- Camshafts and lifters must be hydraulic. No other camshafts or lifters are allowed.
- Lifters must collapse a minimum of .100”.
- Interchanging lifters between engine manufacturers is not allowed.
- Lifters must rotate freely and be manufactured out of magnetic material.
- Camshaft belt or gear drives are not allowed.
- Camshafts may be drilled for a rear spud.
- No lightening, grinding or polishing is allowed.

6. Cylinder Heads

- Stock cast iron production cylinder heads are the only heads allowed. Aftermarket heads are not allowed.
- Chevrolet 1987-1995 Swirl port heads are allowed.
- Ford 302 GTP heads are allowed.
- Vortex, Bowtie, SVO, W-2, Magnum, Gen II, and angle plug heads are not allowed.
- The following Chevrolet casting numbers are not allowed: 040, 041, 186, 187, 291, 370, 414, 432, 461, 461X, 462, 492, 10125320, 10208890, 10239906, 12554290, 14011083, or 14096217.
- Industry standard cylinder head reconditioning is allowed. No other machine work outside of industry standard reconditioning is allowed.
- Carbide cutter relief cuts are allowed below the valve seat, but are not to exceed more than ¼ inch below the top of the valve seat. Minor variances will be allowed in the depth of the relief cut below the valve seat, at the discretion of NRSS Technical Officials, to allow for variances in cylinder head casting and manufacturing.
- Porting or polishing of any kind is not allowed.
- Angle milling is not allowed.

- Valve spring diameters cannot exceed the valve spring diameter of stock OEM production springs. Tapered or Beehive valve springs are not allowed.
- Stock appearing stamped steel rocker arms are the only legal rocker arms on Chevrolet and Ford engines. Chrysler engines may use the stock type stamped steel or stock OEM forged iron adjustable rocker arms. Roller or roller tipped rocker arms are not allowed.
- Screw in rocker arm studs and pushrod guide plates are allowed on Chevrolet and Ford engines. Chrysler rocker arms must be shaft mounted. Pushrods may be hardened, but must have a stock diameter and length.
- Stud girdles are not allowed.

7. Intake Manifolds

- All engines must use the following intake manifold part numbers:
 - Chevrolet – Weiand (Part # 7546, 7467, or 7547-1 X-CEerator)
 - Ford – Weiand (Part # 7515, 8023), Professional Products (Part # 54033)
 - Chrysler – Weiand (Part # 7545)
- Porting, polishing, gasket matching of any kind is not allowed.

8. Oiling System

- Wet sumps are required. Dry sumps are not allowed. The oil pump must be located in the crankcase.
- A minimum of ¾ inch (1 inch recommended) inspection hole in side of oil pan, 2 ½ inches down from pan rail and in line with a journal, is required. Removing the pan may be required if further inspection is necessary.

9. Ignition, Starter & Electronics

- All battery-powered ignitions and magnetos are allowed. A magneto type ignition is recommended. External coils are allowed.
- Cars must have a clearly marked ON/OFF switch within reach of the driver and visible to officials.
- Only one battery is allowed. **The battery must be securely hard mounted and shielded.**
- On board starters are allowed.
- A tachometer is the only electronic monitoring device capable of storing or transmitting information allowed.
- Electronic traction control devices are not allowed.
- MSD type magnetos are not allowed.
- The ignition firing order must remain stock.

10. Exhaust

- Any sprint car type header is allowed, except where noted.
- One collector per side. Slip or merge type headers are not allowed. Mufflers are optional.
- Race cars may be required to have a muffler if local track rules require mufflers.
- Schoenfeld part number 112535, 112530, or Knoxville 14272735-78 are mandatory for all tracks that require the use of a muffler.

- No Tri Y headers

11. Water Pump & Radiator

- Any stock type water pump is allowed.
- The radiator must be in front of the engine.

12. Carburetor

- A minimum of two return springs must be connected to the throttle.
- The throttle pedal must have a toe strap.
- No Willy's Equalizer carburetor.
- Aftermarket metering blocks are allowed.
- Modifying the carburetor for alcohol is allowed.
- The carburetor venturi and booster diameters must remain stock.
- The carburetor choke tower may be removed.
- No carburetor spacer rule.

13. Fuel

- Racing methanol is required. Gasoline is not allowed.
- Nitro, nitrous oxide, or any other oxidizer, with the exception of methanol, is not allowed.
- No fuel additives, with the exception of upper cylinder lubricants, are allowed. Fuel is subject to inspection at any time.

14. Fuel Pump

- A mechanical, belt driven, or cam driven fuel pump is allowed. Cam driven fuel pumps are highly recommended.
- Electric fuel pumps are not allowed.

15. No Titanium, Inconel, Ceramics, DLC, or Nikasil components are allowed.

RaceSaver 305 Engine is NOT ALLOWED in NRSS only Sanctioned Events.

5.3L LS Engine

1. Block

- A factory production iron block is required. Aluminum, bow-tie, or aftermarket blocks are not allowed. The maximum overbore allowed is .060”.
- No interchanging of crankshafts or rods to blocks is allowed.
- Absolutely no lightening of any kind is allowed. All mounts must remain. This includes fuel pump, motor mounts, and all other stock mounts.
- Oversized and roller cam bearings are not allowed.

2. Crankshaft

- A stock OEM Chevrolet crankshaft, with a stroke length of 3.622”, is the only crankshaft allowed.
- No lightening, counterweight knife edging, or counterweight polishing is allowed. Balancing is allowed.
- The crankshaft flange may be machined to fit the rear motor plate and torque ball housing.
- 24 and 58 tooth reluctor wheels are allowed. NRSS tip: Make sure your MSD box is the correct one for your reluctor wheel before ordering.

3. Connecting Rods

- Chevrolet OEM powdered metal connecting rods with a 6.098” center to center length are the only connecting rods allowed.
- Connecting rod bolts may be replaced. Small ends may be bushed and fitted for floating pins. Big ends may be resized to factory specs.
- Grinding or polishing of the connecting rod beams is not allowed. Connecting rod balance pads may be machined to balance rotating and reciprocating mass. One big end and one small end balance pad must remain stock.

4. Pistons/Rings

- Any forged or cast aluminum piston is allowed. Pistons made of anything other than aluminum is not allowed.
- Engines must not exceed 9.50:10 compression ratio with the heads and gasket installed. No exceptions!

5. Cam/Lifters

- Only stock, unaltered, GM part number lifters are allowed.
- The rocker arms must be stock, or a stock type replacement. Roller tip rockers are not allowed.
- Rocker arm trunnions may be upgraded to allow more lift if needed. No other modifications are allowed.
- Push rods must be a stock, or stock type replacement, with a 5/16” diameter.
- The maximum lift at the valve is .600”.
- The camshaft may be drilled for a rear spud.

- No lightening, grinding or polishing is allowed.

6. Cylinder Heads

- Chevrolet OEM aluminum cylinder heads are required. No other cylinder head is allowed.
- The cylinder heads must have a casting number ending in 862 or 706. No other casting number is allowed.
- Industry standard head reconditioning is allowed. No other machine work outside of industry standard reconditioning is allowed.
- The valves may be replaced, but the replacement valves must have a stock stem diameter, stock length, and a stock head diameter (1.89" intake, 1.55" exhaust).
- The seats and guides may be replaced.
- Carbide cutter relief cuts are allowed below the valve seat, but are not to exceed more than ¼ inch below the top of the valve seat. Minor variances will be allowed in the depth of the relief cut below the valve seat, at the discretion of NRSS Technical Officials, to allow for variances in cylinder head casting and manufacturing.
- Angle milling is not allowed.
- No porting, grinding or polishing of any kind is allowed.
- Valve springs must be a single beehive spring, and stock appearing.

7. Intake Manifolds

- All 5.3 LS engines must use the Edelbrock Victor Jr. part number 29087 intake or Holley 300 – 132 single plane.
- No modifications are allowed.
- No porting, polishing, or grinding of any kind is allowed.

8. Oiling System

- Wet sumps are required. Dry sumps are not allowed. The oil pump must be located in the crankcase.
- A minimum of ¾ inch (1 inch recommended) inspection hole in side of oil pan, 2 ½ inches down from pan rail and in line with a journal, is required. Removing the pan may be required if further inspection is necessary.

9. Ignition, Starter & Electronics

- An MSD #6010, MSD #6014, MSD #6014CT or MSD #60143 ignition controller is required. No other ignition controller is allowed.
- Stock or stock appearing replacement coil packs are allowed. Performance coil packs (i.e., Accel, MSD, etc.) are not allowed.
- At this time, no rev limit restrictions will be imposed, but NRSS reserves the right to change this rule in order to guarantee parity between engine options.
- Cars must have a clearly marked ON/OFF switch within reach of the driver and visible to officials.
- Only one battery is allowed. **The battery must be securely hard mounted and shielded.**
- An on-board starter is allowed.

- No electronic monitoring devices capable of storing or transmitting information are allowed, except for a memory tachometer.
- No electronic traction control devices are allowed.
- The ignition firing order must remain stock.

10. Exhaust

- Any sprint car type header is allowed, except where noted.
- One collector per side. Slip or merge type headers are not allowed. Mufflers are optional.
- Race cars may be required to have a muffler if local track rules require mufflers.
- Schoenfeld part number 112535, 112530, or Knoxville 14272735-78 are mandatory for all tracks that require the use of a muffler.
- No Tri Y headers

11. Water Pump & Radiator

- Any stock (LS or small block) type water pump is allowed.
- The radiator must be in front of the engine.

12. Carburetor

- A minimum of two return springs must be connected to the throttle.
- The throttle pedal must have a toe strap.
- No Willy's Equalizer carburetor.
- Aftermarket metering blocks are allowed.
- Modifying the carburetor for alcohol is allowed.
- The carburetor venturi and booster diameters must remain stock.
- The carburetor choke tower may be removed.
- No carburetor spacer rule.

13. Fuel

- Racing methanol only. Gasoline is not allowed.
- Nitro, nitrous oxide, or any other oxidizer, with the exception of methanol, is not allowed.
- No fuel additives, other than upper cylinder lubricants, are allowed. Fuel is subject to inspection at any time.

14. Fuel Pump

- A mechanical, belt driven, or cam driven fuel pump is allowed. Cam driven fuel pumps are recommended.
- Electric fuel pumps are not allowed.

15. No Titanium, Inconel, Ceramics, DLC, or Nikasil components are allowed.

Chevrolet 604 Crate Engine

A sealed Chevrolet 604 crate engine is legal. See the NRSS Technical Director for guidance on competing with the Chevrolet 604. The engine must have factory GM seals and all other rules must be followed.

Engine

Engines will be randomly inspected for legality during the season. There will be an opportunity to have your engine whistled before the season. In 2024 we will be checking compression ratio of feature winning cars at various points during the season among other items. If an engine is found to be non-conforming, the driver will be disqualified for one year, fined \$2,500, and must return all prize money earned during the current season.

Contact the NRSS Technical Director if you have any questions.

Dyno Rule

At the discretion of NRSS Technical Officials, any team may be required to dyno their engine at Perfect Performance. The dyno session will be at the series expense and must be completed within two weeks of the request. The engine will be sealed until that time. This will be done in leu of tearing an engine down initially to determine legality. Tear down may follow depending on results.

Car Construction & Chassis Specifications

See section under Traditional Sprint Specifications.

Tires

See section under Traditional Sprint Specifications.

Weight

- Minimum weight is 1,550 lbs., including fully suited driver. NOTE: There will likely be adjustment to weight or materials allowed for next season.
- You can be weighed at any time during the event.
- Any added weight must be in block form or formed to frame, painted white with the car number stamped on it. Weight must be securely bolted and located between the front motor plate to 12 inches behind rear motor plate. No weight can be added, moved, or replaced during yellow or red flag conditions.
- NRSS officials reserve the right to disqualify any car whose weight mounting procedure or location does not satisfy our specifications (see illustration below).

NOTE: No added weight will be allowed in the open area under the seat. It will be allowed only in the open area in front of the firewall per the rule above.

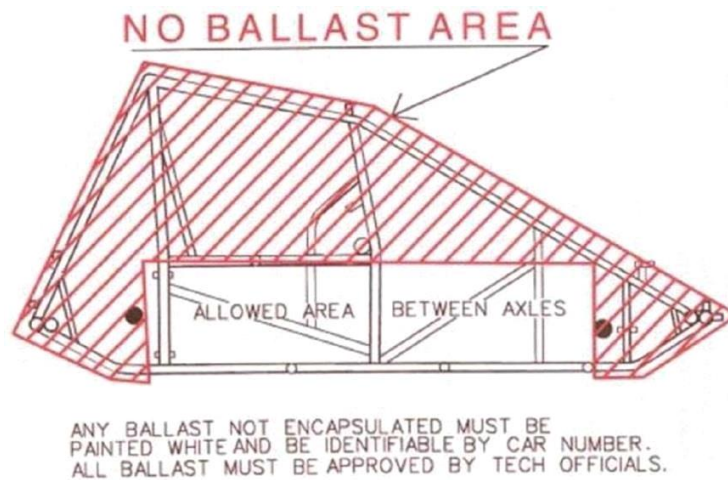

Wing Specifications

1. Top Wing

- The maximum size of the top wing center foil is 25 square feet. The maximum width of the top wing center foil is 60 inches.
- The top wing center foil must be fully sheathed in aluminum. Vent holes are strictly prohibited.
- Wicker bills or gurney lips are only permitted on the center foil of FLAT wings. The gurney lip or wicker bill must not exceed 1" in height. Wicker bills and gurney lips are not allowed on curved top wings.
- Other than the tree mechanism, no moving parts allowed on or in the foil structure.
- The 12-inch section located at the rear of the center foil must not have the belly/curl arc out of proportion with the rest of the center foil. The belly/curl arc must span the entire length of the center foil and appear to be a gradual arc with the deepest point no further back than 48 inches from the leading edge. As measured on a 12-inch straight edge, the belly at 6 inches from the rear of the foil may not be deeper than ½ inch. There is zero tolerance on this ½ inch depth. It is suggested that the wing blueprint specify 15/32-inch depth, so that if any deflection or movement of the wing occurs, the depth will not exceed the ½-inch specification (this ½-inch measurement ensures that the belly/curl arc is gradual).
- The belly/curl arc must start at the radius of the center foil's leading edge and shall not exceed a depth of 2½ inches. Center foil thickness cannot exceed 9 inches. Center foil top surface from side to side must remain flat. Center foil must be one-piece construction. No split or bi-wings will be permitted. Wings must be fabricated of metal alloys only. No fiberglass, carbon fiber or other similar material may be used in the basic framework of the wings. Top wing must not extend beyond outside of rear tires.
- Two stationary foils or rudders will be allowed to run the entire length of the underneath portion of the top wing. Maximum height proportions are 1 inch at the front and 3 inches at the rear. Foil must not exceed 3 inches in height.

- No wing sliders are allowed. The top wing may not be cockpit or driver adjustable while the car is stationary or in motion.
- The top wing must not have an angle that exceeds 20 degrees, when measured with the car on a flat surface. The wing angle will be measured with a straight edge that is approximately 6 feet in length. The straight edge will have an angle finder attached. When checking wing angle, the straight edge will be placed on the ground, parallel to the car, and the angle finder will be zeroed. The straight edge will then be placed on top and center of the wing. One end of the straight edge will be placed on the front lip of the center foil, and the other end of the straight edge will be placed on the rear edge of the center foil. If the wing has a wicker bill, the end of the straight edge will be placed directly in front of the wicker bill. The angle delta between the ground and the wing will then be measured. There is no tolerance. The NRSS Technical Director may allow a small tolerance if the ground is uneven, but a driver should not depend on that when setting the wing angle. Make sure the wing angle is less than 20 degrees. After June 1, 2024, the NRSS will measure wing angle for tech purposes only just before and/or just after heats or feature. The NRSS will measure the top wing one time for teams that have their first event after June 1, 2024.
- The top wing must not be mounted any further back than the axle tubes. When checking for compliance, the car will be positioned on flat ground, and the NRSS Technical Director will hang a plumb bob from the rear edge of the top wing. The plumb bob must touch or hang in front of the axle tube to be legal. There is no tolerance. The NRSS Technical Director may allow a small tolerance if the ground does not appear to be even, but a driver should not depend on that when setting the wing position. Make sure the rear of the top wing is mounted forward of the axle tubes.

2. Front Wing

- The maximum size of the front wing center foil is 6 square feet. The maximum width of the front wing center foil is 36 inches.
- The center foil must be fully sheathed in aluminum. No vent holes allowed.
- Wicker bills or gurney lips are permitted on the front wing center foil. The maximum height of the wicker bill or gurney lip is 1”.
- The maximum distance from the front edge of the front wing center foil to the front edge of the front axle must not exceed 20 inches.
- The front wing must be mounted with the front edge of the front wing center foil at least 1” behind the front edge of the front bumper. The front wing center foil must be mounted flat from side to side.
- The front wing center foil must be one piece. No split or bi-wings are allowed.
- The front wing must be fabricated of metal alloys only. No fiberglass, carbon fiber or other similar material may be used in the basic framework of the wings.
- The front wing must not extend beyond the outside of the front tires. The front wing may not be cockpit or driver adjustable while the car is stationary or in motion.
- No moving parts are allowed on or in the front wing foil structure.

- The 5" section located at the rear of the front foil must not have a bell/curl arc that is out of proportion with the rest of the front foil. As measured on a 5-inch straight edge, the belly at 2 ½ inches from the rear of the foil may not be deeper than 3/8 inch. There is zero tolerance on this 3/8-inch depth. It is suggested that the wing blueprint specify 11/32- inch depth, so that if any deflection or movement of the wing occurs, the depth will not exceed the 3/8-inch specification (this 3/8-inch measurement ensures that the belly/curl arc is gradual).
- The belly/curl arc must span the entire length of the front foil and appear to be a gradual arc with the deepest point, no further back than 12 inches from the leading edge. The belly/curl arc must start at the front foil's leading edge and shall not exceed a depth of 2 inches. Top foil thickness cannot exceed 3.6 inches.
- No rudders or fins are allowed on the front wings.

Please keep in mind that we will be correcting any items we deem to be costing the racers too much money after this season. We will give as much notice as possible to these corrections but every effort will be made to keep this class affordable and fun. The intention is to lock the wing rules before the 2025 season begins.