

KARGO KING

Detachable System



NO WINCH. ROLL OFF SYSTEM

KARGO KING
ROLL-OFF SYSTEMS

cFive Detachable System

LANDSCAPING PACKAGE

Models	Lift Capacity	Subframe Length	Chassis Class	Recommended Cab to Axle
DS-11-110-24V-KLP	10,500 lbs. / 4.76 T	11' / 3.35M	Class 5	84" / 2.13M

KEY FEATURES

- Easy to Operate – 2 Control Levers, Outside Controls
- Approx. Payload with Body: 8,000lbs | without Body: 10,500 lbs capacity
- Dump Angle = 35° - 37° approx (45° with a dump cylinder)
- Compact and Lightweight
- Reliable and Low Maintenance
- Safe & Secure 2 point lift
- Powerpack driven - avoid costly start up costs of Central Hydraulics
- Reduced Weight vs cSix Series

Landscapers require versatile truck equipment.

The Landscaper understands this dilemma better than most. The cFive offers multiple bodies that are commonly used in the day to day operations of a landscaper.

A bin or landscape body to haul materials such as soil, gravel, plants, and tools or a flat deck with a beavertail that allows them to load at ground level and transport small landscaping machinery like mowers, small tractors, and spreaders.

For landscapers who operate in snow removal the Kargo King cFive offers an accessory deck to accommodate salt and sand spreaders.

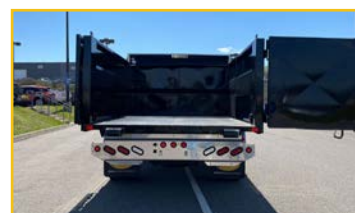
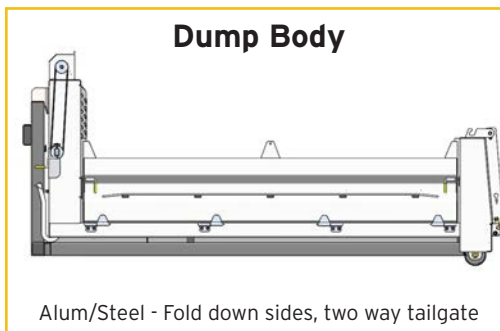
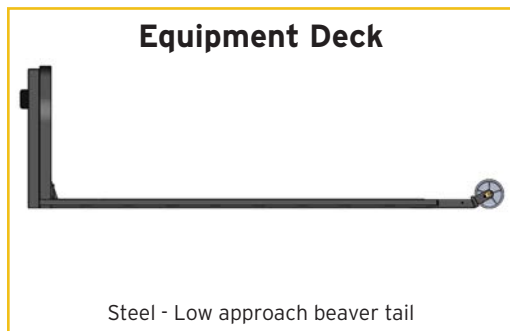
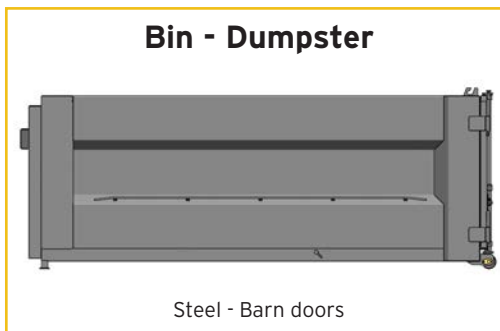
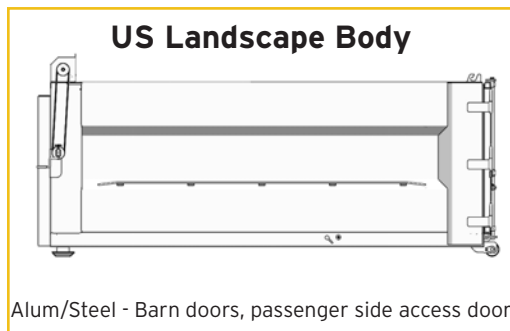

Subject to change without notice, images are for demonstrative purpose only

LANDSCAPING PACKAGE

Models	Lift Capacity	Subframe Length	Chassis Class	Recommended Cab to Axle
DS-15-140-KLP	15,000 lbs. / 6.8T	14' / 4.26M	Class 5/6	120" / 3.04M

KEY FEATURES

- Easy to Operate – 2 Control Levers, Outside Controls
- Dump Angle = 35° - 37° approx (45° with a dump cylinder)
- Compact and Lightweight
- Reliable and Low Maintenance
- Safe & Secure 2 point lift
- Also available in 84" and 108" cab to axle (CA measurement)
- PTO driven

The cSix provides added versatility and flexibility with a longer subframe and added payload capacity compared to the cFive.



Bin - Dumpster



Steel - Barn doors

Equipment Deck



Steel - Low approach beaver tail

Dump Body

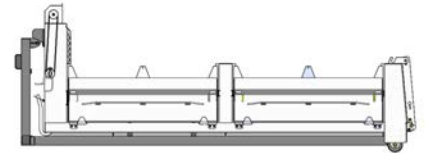

Alum/Steel - Fold down sides, two way tailgate

Subject to change without notice, images are for demonstrative purpose only

KARGO KING cSix Detachable System

BUILDING SUPPLY

Models	Lift Capacity	Subframe Length	Chassis Class	Recommended Cab to Axle
DS-15-140-KLP	15,000 lbs. / 6.8T	14' / 4.26M	Class 5/6	120" / 3.04M

KEY FEATURES

- Easy to Operate – 2 Control Levers, Outside Controls
- Dump Angle = 35° - 37° approx (45° with a dump cylinder)
- Compact and Lightweight
- Reliable and Low Maintenance
- Safe & Secure 2 point lift
- PTO driven

There may not be a better fit for the Kargo King Detachable System than the Building Supply Industry.

A typical Building Supply fleet consists of a truck equipped with a steel Flat Deck for common lumber and material delivery and a truck equipped with a Van Body for delivery of materials that need protection from the elements.

By adopting the Kargo King Detachable concept, Yard/Fleet Managers eliminate the need for redundant trucks while increasing operational efficiency. Lumber Decks and Van Bodies are pre-loaded while the truck is out generating revenue for the business.

Additionally, windows and doors are loaded at ground level thus eliminating the need for loading on potentially slippery ramps or decks permanently mounted at truck frame level.

Building Supply Centres can supplement their mix of truck bodies with the addition of the Detachable Waste Bin if outsourcing has become cost prohibitive or a Salt/Sand Spreader for winter yard maintenance.



Lumber Deck



Alum/Steel - Barn doors, passenger side access door

Bin - Dumpster

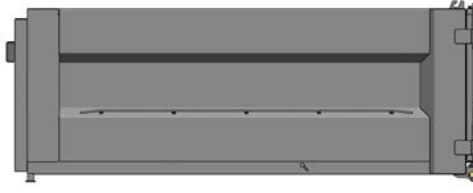

Steel - Barn doors



Van Body



Curtainsider Body



Subject to change without notice, images are for demonstrative purpose only