



**PARTS LIST
OPERATING AND
SERVICE MANUAL**



**SERIES: 30 & 70
BLOWERS**

Models:
GGB__B
GGG__C_

**D-9-610
Version 10
November, 2005**

**MAINTAIN BLOWER RELIABILITY AND PERFORMANCE
WITH GENUINE DUROFLOW PARTS AND SUPPORT SERVICES
FROM GARDNER DENVER**

Factory genuine parts, manufactured to design tolerances, are developed for optimum dependability --- specifically for your blower. Design and material innovations are born from years of experience with hundreds of different blower applications. When you specify factory genuine parts you are assured of receiving parts that incorporate the most current design advancements . . . manufactured in our state-of-the-art blower factory under exacting quality standards.

Your **AUTHORIZED DISTRIBUTOR** offers all the backup you require. A worldwide network of authorized distributors provides the finest product support in the blower industry.

Your **AUTHORIZED DISTRIBUTOR** can support your blower investment with these services:

1. Trained parts technical representatives to assist you in selecting the correct replacement parts.
2. Complete inventory of new machines and new, genuine factory parts.
3. A full line of factory tested AEON™ PD Synthetic Blower Lubricants specifically formulated for optimum performance in all blowers.
4. Authorized Distributor service technicians are factory-trained and skilled in blower maintenance and repair. They are ready to respond and assist you by providing fast, expert maintenance and repair services.

For the location of your local authorized DuroFlow blower distributor refer to the yellow pages of your phone directory, check the Web site at www.gardnerdenver.com or contact:

**Gardner Denver
1800 Gardner Expressway
Quincy, IL 62305
Phone: (217) 222-5400
Fax: (217) 221-8780**

REMANUFACTURED BLOWERS

Whenever a DuroFlow blower requires replacement or repair, Gardner Denver offers an industry unique, factory remanufactured blower exchange program. From its modern Remanufacturing Center in Indianapolis, IN, Gardner Denver is committed to supplying you with the highest quality, factory remanufactured DuroFlow blowers that are guaranteed to save you time, aggravation and money.

Immediately Available

Repair downtime costs you money, which is why Gardner Denver maintains a large inventory of remanufactured blowers at all times, ready for immediate delivery.

Skilled Craftsmen

Our Remanufacturing assembly technicians average over 20 years experience with air compression products.

Precision Remanufacturing

All potentially usable parts are thoroughly cleaned, inspected and analyzed. Only those parts that can be brought back to original factory specifications are

remanufactured. Every remanufactured DuroFlow blower receives a new overhaul kit: bearings, seals, sleeves and gaskets.

Extensive Testing

Gardner Denver performs testing that repair houses just don't do. Magnaflux and ultrasonic inspection spot cracked or stressed castings, monochromatic light analysis exposes oil leaks, coordinate measurement machine inspects to +/- .0001", and slip and hot run testing insure that all remanufactured DuroFlow blowers meet factory performance specifications.

Latest Technology

Factory remanufactured DuroFlow blowers incorporate all of the latest new blower design improvements.

Warranty

Gardner Denver backs up every remanufactured blower with a new warranty . . . 18 months from purchase, 12 months from service.

Gardner Denver remanufactured air ends deliver *quality without question . . . year in and year out.*

GARDNER DENVER LUBRICANT ORDER INFORMATION

Re-order Part Numbers for Factory-Recommended Lubricants.

AEON PD Synthetic Lubricant or AEON PD-Food Grade Synthetic Lubricant

AEON PD Synthetic Lubricant

Description	Part Number
1 Quart	28G23
Case/12Quarts	28G24
5 Gallon Pail	28G25
55 Gallon Drum	28G28

AEON PD-Food Grade Synthetic Lubricant

Description	Part Number
1 Quart	28H97
Case/12Quarts	28H98
5 Gallon Pail	28H99
55 Gallon Drum	28H100

Call your local DuroFlow Distributor to place your order for Gardner Denver lubricants. Your Authorized Gardner Denver Distributor is:

FOREWORD

Duroflow[®] blowers are the result of advanced engineering and skilled manufacturing. To be assured of receiving maximum service from this machine, the owner must exercise care in its operation and maintenance. This book is written to give the operator and maintenance department essential information for day-to-day operation, maintenance and adjustment. Careful adherence to these instructions will result in economical operation and minimum downtime.

DANGER

Danger is used to indicate the presence of a hazard which will cause severe personal injury, death, or substantial property damage if the warning is ignored.

WARNING

Warning is used to indicate the presence of a hazard which can cause severe personal injury, death, or substantial property damage if the warning is ignored.

CAUTION

Caution is used to indicate the presence of a hazard which will or can cause minor personal injury or property damage if the warning is ignored.

NOTICE

Notice is used to notify people of installation, operation or maintenance information which is important but not hazard-related.

SAFETY PRECAUTIONS

Safety is everybody's business and is based on your use of good common sense. All situations or circumstances cannot always be predicted and covered by established rules. Therefore, use your past experience, watch out for safety hazards and be cautious. Some general safety precautions are given below:

DANGER

Failure to observe these notices could result in injury to or death of personnel.

- **Keep fingers and clothing away** from blower inlet and discharge ports, revolving belts, sheaves, drive coupling, etc.
- **Do not use the air discharge** from this unit for breathing - not suitable for human consumption.
- **Do not loosen or remove** the oil filler plug, drain plugs, covers, or break any connections, etc., in the blower air or oil system until the unit is shut down and the air pressure has been relieved.
- **Electrical shock** can and may be fatal.
- **Blower unit must be grounded** in accordance with the National Electrical Code. A ground jumper equal to the size of the equipment ground conductor must be used to connect the blower motor base to the unit base.
- **Open main disconnect switch**, tag and lockout before working on the control.
- **Disconnect the blower** unit from its power source, tag and lockout before working on the unit - the machine may be automatically controlled and may start at any time.

WARNING

Failure to observe these notices could result in damage to equipment.

- **Stop the unit** if any repairs or adjustments on or around the blower are required.
- **Disconnect the blower** unit from its power source, tag and lockout before working on the unit - the machine may be automatically controlled and may start at any time.
- **Do not exceed** the rated maximum speed shown on the nameplate.
- **Do not operate unit** if safety devices are not operating properly. Check periodically. Never bypass safety devices.

TABLE OF CONTENTS

Page

Maintain Blower Reliability and Performance with Genuine DuroFlow Parts and Support Services	i
Remanufactured Blower Program (see page 19 for complete details)	i
Gardner Denver Lubricant Order Information	ii
Foreword	iii
Safety Precautions	iv
Index	vi
List of Illustrations	vii
Matrix/Menu	1
INTRODUCTION	
Your Key To Trouble Free Service	2
SECTION 1, GENERAL INFORMATION	
Inspection	3
Removing Protective Materials At Start-up	3
Storage	3
Blower Mounting Configurations	4
Outline	5
Blower Outline Dimension Chart	6
SECTION 2, INSTALLATION	
Location	7
Foundation and Base	7
Mounting Configurations	7
Drive Installation	7
Piping	9
SECTION 3, LUBRICATION	
Recommended Lubricant	10
Lubrication Instructions	10
Air Seal Vent Systems	12
Oil Sump Breathing System	12
SECTION 4, OPERATION	
Limitations	14
Safety Precautions	14
Blower Startup Checklist	16
SECTION 5, MAINTENANCE AND TROUBLESHOOTING	
Key Points for Long Blower Life	17
Trouble Shooting	17
SECTION 6, SERVICE OPTIONS	
Factory Remanufactured Blower Program	19
Parts Ordering Instructions	20
Overhaul Kits	20
SECTION 7, PARTS LISTS AND EXPLODED VIEWS	
30 Series Duroflow Blower	21
70 Series Duroflow Blower	23
Warranty	26
Warranty Registration	Last Page

INDEX

<p>AEON PD Food Grade Lubricant Part Numbers . 10</p> <p>AEON PD Lubricant Part Numbers 10</p> <p>Air Seal Vent Systems 12</p> <p>Alignment, Belt Drive 9</p> <p>Base and Foundation 7</p> <p>Belt Drive Alignment 9</p> <p>Blower Startup Checklist 16</p> <p>Checklist, Blower Startup 16</p> <p>Drive Installation 7</p> <p style="padding-left: 20px;">Belt Drive Alignment 9</p> <p style="padding-left: 20px;">Driver Location 9</p> <p style="padding-left: 20px;">Overhung Load Calculations and Limitations . . 7</p> <p>Driver Location 9</p> <p>Factory Remanufactured Blower Program 19</p> <p>Foreword iii</p> <p>Foundation and Base 7</p> <p>GENERAL INFORMATION, SECTION 1 3</p> <p>INSTALLATION, SECTION 2 7</p> <p>Installation, Location 7</p> <p>Key Points for Long Blower Life 17</p> <p>Limitations, Operation 14</p> <p>Location, Installation 7</p> <p>Lubricant, Recommended 10</p> <p>Lubricant Order Information ii</p> <p>LUBRICATION, SECTION 3 10</p> <p>Lubrication Instructions 10</p>	<p>Lubrication Service, Air Seal Vent Systems 12</p> <p>Lubrication Service, Oil Sump Breathing System . 12</p> <p>MAINTENANCE AND TROUBLESHOOTING, SECTION 5 17</p> <p style="padding-left: 20px;">Matrix/Menu 1</p> <p style="padding-left: 20px;">Mounting Configurations 7</p> <p style="padding-left: 20px;">Oil Sump Breathing System 12</p> <p>OPERATION, SECTION 4 14</p> <p>Overhaul Kits 20</p> <p>Overhung Load Calculations and Limitations 7</p> <p>PARTS LISTS AND EXPLODED VIEWS, SECTION 7 21</p> <p style="padding-left: 20px;">Parts Ordering Instructions 20</p> <p style="padding-left: 20px;">Piping 9</p> <p style="padding-left: 20px;">Precautions, Safety iv, 14</p> <p style="padding-left: 20px;">Product Support, DuroFlow i</p> <p style="padding-left: 20px;">Recommended Lubricant 10</p> <p style="padding-left: 20px;">Remanufactured Blower Program, Factory i, 19</p> <p style="padding-left: 20px;">Repair Parts 19</p> <p style="padding-left: 20px;">Safety Precautions iv, 14</p> <p>SERVICE OPTIONS, SECTION 6 19</p> <p style="padding-left: 20px;">Startup Checklist, Blower 16</p> <p style="padding-left: 20px;">Storage 3</p> <p style="padding-left: 20px;">Trouble Shooting 17</p> <p style="padding-left: 20px;">Warranty 26</p> <p style="padding-left: 20px;">Warranty Registration 27</p> <p>YOUR KEY TO TROUBLE FREE SERVICE, INTRODUCTION 2</p>
-------------------------------------------------------------------------------------------------------------------------------------------------------------------------------------------------------------------------------------------------------------------------------------------------------------------------------------------------------------------------------------------------------------------------------------------------------------------------------------------------------------------------------------------------------------------------------------------------------------------------------------------------------------------------------------------------------------------------------------------------------------------------------------------------------------------------------------------------------------------------------------------------------------------------------------------------------------------------------------------------------------------------------------------------------------------------------------------------------------------------------------------------------------------------------------------------------------------------------------------------------------------------	------------------------------------------------------------------------------------------------------------------------------------------------------------------------------------------------------------------------------------------------------------------------------------------------------------------------------------------------------------------------------------------------------------------------------------------------------------------------------------------------------------------------------------------------------------------------------------------------------------------------------------------------------------------------------------------------------------------------------------------------------------------------------------------------------------------------------------------------------------------------------------------------------------------------------------------------------------------------------------------------------------------------------------------------------------------------------------------------------------------------------------------------------------------------------------------------------------------------------------------------------------------------------------------------------------------------------------------------------------------------------------------------------------------------------------------------------------------------------------------------------------------------------------------------------------------------------------------------------------------------------------------------------------------

LIST OF ILLUSTRATIONS

Figure 1-1 Blower Configuration Changes 4

Figure 1-2 Outline 5

Figure 1-3 Blower Outline Dimension Chart 6

Figure 2-1 Belt Drive Overhung Load Limitations 8

Figure 3-1 Approximate Oil Sump Capacities 10

Figure 3-2 AEON PD Synthetic Lubricant 10

Figure 3-3 70 Series - Column Type Sight Glass Location 11

Figure 3-4 Viscosity Recommendation 13

Figure 4-1 Maximum Operating Limitations 15

EXPLODED VIEWS

30 Series Blower - 200GGB810 21

70 Series Blower - 201GGG810 23

DUROFLOW BLOWERS - 30 & 70 SERIES MATRIX/MENU

NOTICE TO CUSTOMER - To find the construction options for your blower unit, FILL IN THE BALANCE OF LETTERS OR NUMBERS FROM YOUR UNIT NAMEPLATE
COLUMN NUMBER:

	G	G									
	1	2	3	4	5	6	7	8	9	10	11

FOLLOW THE LINE DOWN AND OVER FROM EACH SPACE THUS FILLED IN TO FIND THE APPROPRIATE CONSTRUCTION OPTION WITH WHICH YOUR MACHINE IS EQUIPPED.

COLUMN 1 - BASIC DESIGNATOR _____

COLUMN 2 - PRODUCT FAMILY _____
G. INDUSTRIAL BLOWER

COLUMN 3 - GEAR DIAMETER _____
B. 3" - 30 Series G. 7" - 70 Series

COLUMN 4 - CASE LENGTH _____

	30 Series	70 Series
A.	4"	9"
B.	6"	12"
C.		15"
D.		18"
E.		23"
F.		28"

COLUMN 5 - CONSTRUCTION _____

- A. VERTICAL-TOP HAND-CENTRAL TIMED
- B. VERTICAL-BOTTOM HAND-CENTRAL TIMED
- C. HORIZONTAL-LEFT HAND-CENTRAL TIMED
- D. HORIZONTAL-RIGHT HAND-CENTRAL TIMED
- * E. SCHRAMM: VERTICAL-TOP HAND-CENTRAL TIMED

COLUMN 6 - DESIGN VERSION _____

- B. 30 SERIES
- C. 70 SERIES

COLUMN 7 - ADDITIONAL DESCRIPTION _____

- A. STANDARD, NO MODIFICATION

COLUMNS 8 THRU 11 - MODIFICATION NUMBER * _____

* NOT INCLUDED IN THIS PUBLICATION, CONSULT FACTORY.

INTRODUCTION

YOUR KEY TO TROUBLE FREE SERVICE

Thank you for investing in DuroFlow quality. The DuroFlow reputation for rugged dependability has been earned by over 70 years of service in demanding, industrial operations where downtime cannot be tolerated and efficient blower performance is expected.

Your DuroFlow blower is a precision engineered blower that has been carefully manufactured and thoroughly tested at the state-of-the-art Gardner Denver Blower Factory in Sedalia, Missouri.

As with other precision machinery, there are several relatively simple installation, operation and maintenance

procedures that you must observe to assure optimum blower performance. There is no guesswork in the manufacture of your highly advanced DuroFlow blower and there must be none in preparing the blower to get the job done in the field.

The purpose of this manual is to help you properly install, operate and maintain your DuroFlow blower. It is essential that you review all sections of this manual in preparation for installing your blower. Follow the instructions carefully and you will be rewarded with trouble-free DuroFlow service . . . year in and year out.

SECTION 1 GENERAL INFORMATION

INSPECTION

Before uncrating, check the packing slip carefully to be sure all the parts have been received. All accessories are listed as separate items on the packing slip, and small important accessories such as relief valves can be overlooked or lost. After every item on the packing slip has been checked off, uncrate carefully. Register a claim with the carrier for lost or damaged equipment.

The inlet and discharge openings are fitted with protective covers to prevent dirt and moisture from entering the blower during shipping and installation.

NOTICE

Do not remove and dispose of the covers until final checking and installation.

Covers are lined with a "Corrosion Inhibitor" which will inhibit rust for a period of six months. Retain covers for use in reshipment or relocation of the unit.

Temporarily remove the protective covers and inspect interior of air chamber for foreign material or heavy rusting. Turn driveshaft to assure that lobes rotate smoothly without binding. New blowers may be difficult to turn by hand due to friction of the air seals. Once in motion however, there should be no indication of interference between the rotors and the housing or end-plates. Report any suspected mechanical problems immediately to your authorized DuroFlow distributor.

REMOVING PROTECTIVE MATERIALS AT START-UP

Blower inlet and discharge are temporarily capped to keep out dirt and other contaminants during shipment. These covers must be removed before start-up.

WARNING

Failure to remove covers from blower inlet and discharge prior to start-up will cause machine damage.

STORAGE

Your DuroFlow blower was packaged at the factory with adequate protection to permit normal storage for up to six (6) months. Under the best of storage conditions there is still a potential for damage to occur. Extended storage preparation is available from the factory, prior to shipment, at a small additional charge. If the unit is to be stored under adverse conditions or for extended periods of time, additional measures should be taken to prevent unwarrantable damage.

1. Store the blower in a clean, dry area.
2. Make certain inlet and discharge air ports are tightly covered to prevent foreign material from entering the air chamber.
3. All exposed, non-painted surfaces should be protected against rust and corrosion.
4. Make sure all vent breathers are in place.
5. Provide adequate protection to avoid accidental mechanical damage.
6. In high humidity or corrosive environments, additional measures may be required to prevent rusting of the internal surfaces. Mist spraying the impellers and air chamber with a rust preventative will protect these surfaces from rusting. To prevent rusting of gears and bearings, add one pint of VCI oil in each oil reservoir. (Ref. Part Number 28H280 per quart)
7. Rotate shaft by hand weekly to prevent bearings from taking a set and to keep seals soft.

CAUTION

Before running the blower, drain the oil and replace to the proper operating level with clean, fresh lubricant.

WARNING

Rotating components will cause severe injury in case of personal contact. Keep hands away from blower inlet and discharge ports.

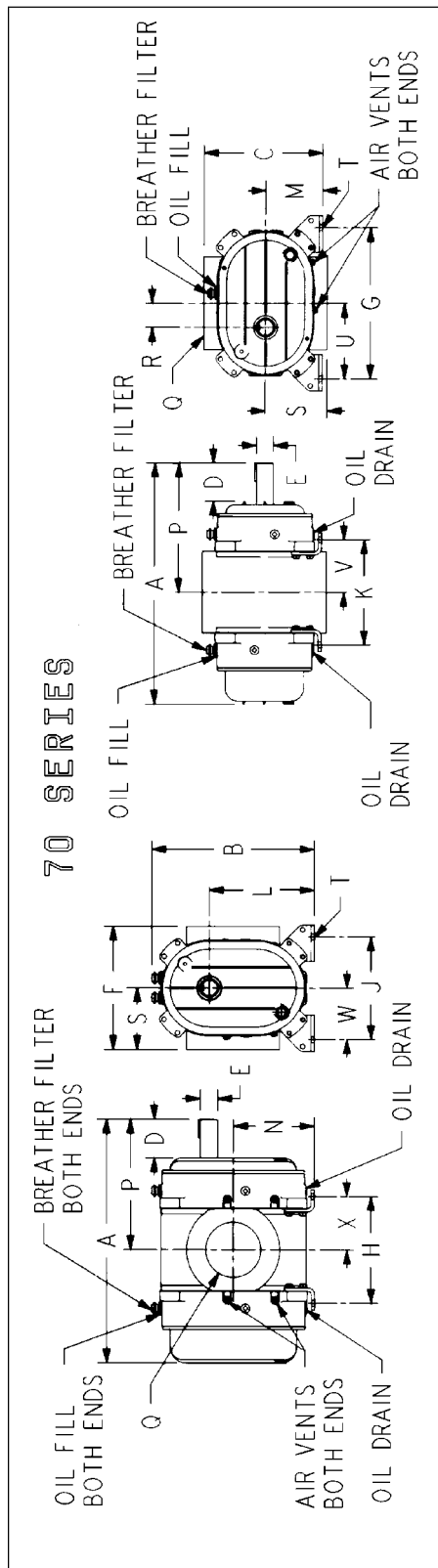
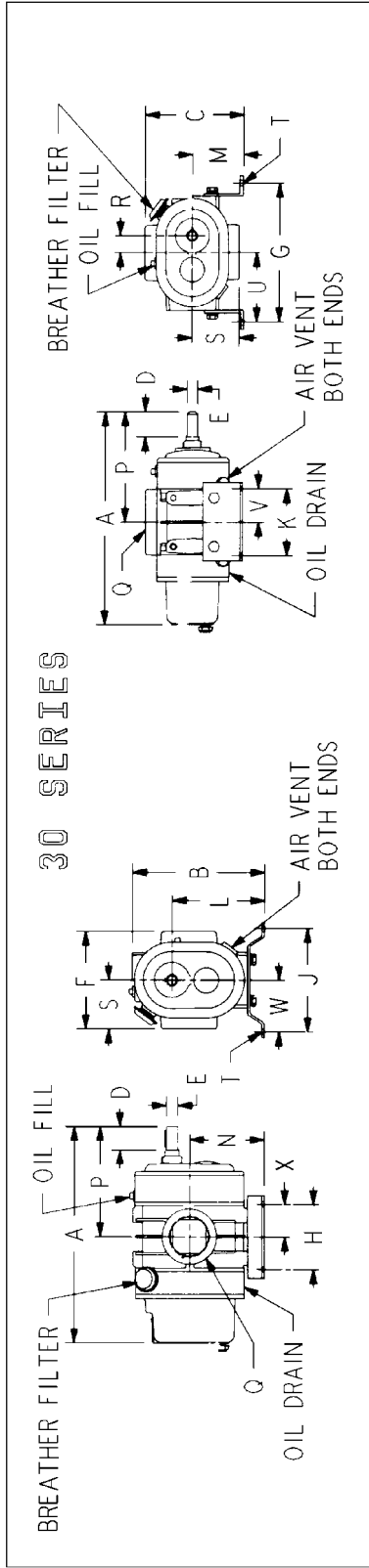

FIGURE 1-2 - OUTLINE

BLOWER OUTLINE DIMENSION CHART										
Dimensions	Models									
	3004	3006	7009	7012	7015	7018	7023	7028		
A	16.64	18.64	32.42	35.43	38.44	41.44	46.44	51.44		
B	11.62	11.62	23.62	23.62	23.62	23.62	23.62	23.62		
C	8.81	8.81	17.25	17.25	17.25	17.25	17.25	17.25		
D	2.06	2.06	5.68	5.68	5.64	5.64	5.62	5.62		
E DIA.	1.000	1.000	2.500	2.500	2.500	2.500	2.500	2.500		
F	8.82	8.62	18.00	18.00	18.00	18.00	18.00	18.00		
G	12.50	12.50	22.00	22.00	22.00	22.00	22.00	22.00		
H	4.00	5.50	12.50	15.50	18.50	21.50	26.50	31.50		
J	9.00	9.00	15.00	15.00	15.00	15.00	15.00	15.00		
K	4.00	5.50	12.50	15.50	18.50	21.50	26.50	31.50		
L	8.06	8.06	15.25	15.25	15.25	15.25	15.25	15.25		
M	4.50	4.50	8.25	8.25	8.25	8.25	8.25	8.25		
N	6.56	6.56	11.75	11.75	11.75	11.75	11.75	11.75		
P	8.36	9.36	17.49	18.99	20.47	21.97	24.47	26.97		
Q	2-1/2" NPT	3" NPT	6" NPT	8" FLG	8" FLG	10" FLG	12" FLG	12" FLG		
R	1.50	1.50	3.50	3.50	3.50	3.50	3.50	3.50		
S	4.41	4.31	9.00	9.00	9.00	9.00	9.00	9.00		
T DIA.	.53	.53	.88	.88	.88	.88	.88	.88		
U	6.25	6.25	11.00	11.00	11.00	11.00	11.00	11.00		
V	2.00	2.75	6.25	7.75	9.25	10.75	13.25	15.75		
W	4.50	4.50	7.50	7.50	7.50	7.50	7.50	7.50		
X	2.00	2.75	6.25	7.75	9.25	10.75	13.25	15.75		
* See Figure 2-5, Page 9, for available connectors.										
APPROXIMATE WEIGHT										
MODEL	3004	3006	7009	7012	7015	7018	7023	7028		
LBS.	120	135	820	920	1000	1080	1160	1260		

FIGURE 1-3 - BLOWER OUTLINE DIMENSION CHART

SECTION 2 INSTALLATION

LOCATION

Whenever possible, install the blower in a clean and dry place that is both well lighted and well ventilated. Provide plenty of room for easy inspection and maintenance.

FOUNDATION AND BASE

For permanent installations we recommend concrete foundations be provided, and the equipment should be grouted to the concrete. Use non-shrinking grout only. It is necessary that a suitable base be used, such as steel combination base under the blower and motor, or a separate sole plate under each. The blower feet must be 100% supported. Before grouting, equipment must be leveled, free of all strains, and anchored so no movement will occur during curing of grout. After grout has completely hardened, a recheck is necessary to compensate for shrinkage. If required, add shims under blower feet after final tightening of foundation anchor bolts to remove strain from the blower housing.

Where jack screws or wedges are used during grouting, they must be backed off or removed before final tightening of anchor bolts.

Where a concrete foundation is not feasible, care must be taken to insure that equipment is firmly anchored to adequate structural members. The blower must be installed on a flat, level surface and bolted down evenly to prevent warping or strain. Internal clearances are very critical and serious damage or failure can result from housing distortion.

NOTICE

If the unit is not flat within .002 of an inch, it will be necessary to shim the blower feet at installation.

MOUNTING CONFIGURATIONS

All DuroFlow blowers are center timed allowing rotation in either direction.

DuroFlow blowers are shipped in the vertical configuration (horizontal airflow.) If a horizontal configuration is desired, the blower can be laid on its side after repositioning breathers, oil filler drain plugs and mounting feet as indicated in the installation drawing, FIGURE 1-2, page 5. **To assure proper lubrication, the blower must be laid over in the direction that places the oil sight glass(es) below the horizontal centerline of the blower.** See FIGURE 1- 1, page 4, for additional configuration information.

When converting 30 series blowers from vertical to horizontal configurations, the horizontal mounting feet are required. Order horizontal mounting feet from your DuroFlow Distributor. The 70 series blowers can be converted from vertical to horizontal configurations utilizing the same four (4) feet originally shipped with the blower.

The blower must be mounted level with the driveshaft in the horizontal position. Some models have interconnected oil sumps and operation in an out-of-level condition will result in inadequate lubricant distribution and subsequent premature blower failure.

DRIVE INSTALLATION

When selecting a V-belt drive, check to be sure the shaft overhung load limitation is not exceeded.

Overhung Load Calculations and Limitations – An excessive overhung condition exists when the belt pull on the blower shaft exceeds the maximum allowable moment listed in “Maximum Allowable Moment” chart in FIGURE 2-1, page 8. Excessive overhung load conditions must be avoided or bearing failure and shaft breakage will result.

WARNING

Exceeding overhung load limitations leads to unwarrantable premature bearing failure and shaft breakage.

The location of the sheave on the blower shaft greatly affects the stress in the shaft. The optimum blower sheave positioning is as close as possible to the blower drive cover, not to exceed dimension “C” shown in maximum allowable moment chart, FIGURE 2-1, page 8.

To calculate the shaft moment for a given V-belt drive arrangement, first calculate the belt pull using the formula for belt pull in FIGURE 2-1, page 8. Insert the calculated belt pull into the formula for calculation of shaft moment in FIGURE 2-1, page 8, to arrive at the calculated shaft moment.

The calculated shaft moment must not exceed the maximum allowable moment listed in the chart, FIGURE 2-1, page 8. If the calculated shaft moment exceeds the maximum allowable moment:

- Increase Sheave Diameters to Reduce Belt Pull
- Use Jackshaft Drive
- Use Direct Coupled or Gearbox Drive

Series	Gear Diameter (Inches)	Dimensions (Inches)			Maximum Allowable Moment (LB-IN)
		A	B	C	
30	3	4.75	1.87	.94	1449
70	7	9.45	3.82	.63	14469

MAXIMUM ALLOWABLE MOMENT

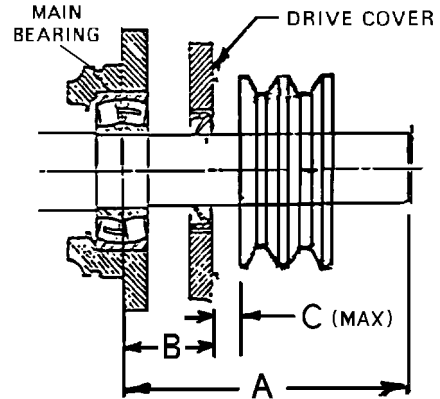

DRIVE SHAFT ILLUSTRATION

Z	Ac	Z	Ac	Z	Ac	Z	Ac	Z	Ac	Z	Ac
0.000	1.000	0.250	0.966	0.500	0.926	0.750	0.879	1.000	0.823	1.250	0.751
0.025	0.997	0.275	0.962	0.525	0.922	0.775	0.874	1.025	0.816	1.275	0.742
0.050	0.994	0.300	0.958	0.550	0.917	0.800	0.869	1.050	0.810	1.300	0.734
0.075	0.990	0.325	0.954	0.575	0.913	0.825	0.864	1.075	0.803	1.325	0.725
0.100	0.987	0.350	0.951	0.600	0.908	0.850	0.858	1.100	0.796	1.350	0.716
0.125	0.983	0.375	0.947	0.625	0.904	0.875	0.852	1.125	0.789	1.375	0.706
0.150	0.980	0.400	0.943	0.650	0.899	0.900	0.847	1.150	0.782	1.400	0.697
0.175	0.977	0.425	0.939	0.675	0.894	0.925	0.841	1.175	0.774	1.425	0.687
0.200	0.973	0.450	0.935	0.700	0.889	0.950	0.835	1.200	0.767		
0.225	0.969	0.475	0.930	0.725	0.884	0.975	0.829	1.225	0.759		

ARC OF CONTACT FACTORS

$$\text{Belt Pull} = \left[\frac{2.5 - A_c}{A_c} \right] \left[\frac{125954 \times \text{HP} \times \text{S.F.}}{D \times \text{RPM}} \right]$$

- Key:
- A_c = Arc of Contact Factor (Refer to Arc of Contact Factors Chart above)
 - H_p = Blower Horsepower for Operating Conditions
 - S.F. = Actual Drive Service Factor
 - D = Blower Sheave Pitch Diameter in Inches
 - RPM = Blower Sheave Speed
 - Z = $\frac{\text{Large Sheave Pitch Diameter (in)} - \text{Small Sheave Pitch Diameter (in)}}{\text{Sheave Center Distance (in)}}$

CALCULATION OF BELT PULL

$$\text{Shaft Moment (LB-IN)} = \text{Belt Pull} \times \left[B + C + \left(\frac{\text{Sheave Width}}{2} \right) \right]$$

CALCULATION OF SHAFT MOMENT

FIGURE 2-1 - BELT DRIVE OVERHUNG LOAD CALCULATIONS

Driver Location - To properly balance the air load stress on the blower drive shaft, locate the driver on the inlet side for a vertical mounted blower and on the shaft side for a horizontal mounted blower.

Belt Drive Alignment - Belt drives must be carefully aligned, with the motor and blower sheaves parallel to each other and in the same plane. Belt tension should be carefully adjusted according to the belt manufacturer's recommendations using a Tension Tester.

 WARNING
Overtightening belts produces heavy bearing loads and leads to unwarrantable premature failure.

On direct drive blowers, align the couplings so that the offset and angular misalignment does not exceed .003" total indicator reading (TIR). Lubricate coupling according to manufacturer's specification. With factory installed drives, proper alignment has been established before shipment. During shipping, handling and installation, it is likely that the alignment has been disturbed and final adjustment must be made before start-up.

PIPING

All 30 Series DuroFlow blowers have female threaded inlet and discharge connections. The connections are large enough to handle maximum volume with

minimum friction loss. Reducing the pipe diameter on either inlet or discharge will create unwanted restrictions that increase the overall pressure differential and discharge temperature of the blower.

The 70 Series DuroFlow blowers have flat face inlet and discharge flanges with ANSI 125 lb. bolt patterns.

When installing the blower, avoid subjecting the inlet and discharge connections to strains caused by misalignment of the connecting pipes. Never allow the blower to carry the weight of the pipe.

Piping strain and misalignment stress will distort the blower during operation, resulting in loss of critical internal clearances. Loss of internal clearances will result in serious machine damage and premature, unwarrantable blower failure.

Whenever possible, install a spool or sleeve-type expansion joint between the blower and the piping. Where a flexible connection is not possible, the weight of the rigid connection and piping must be separately supported, and thermal pipe growth must be accommodated.

 WARNING
Thoroughly clean all system piping internally before connecting to the blower.

SECTION 3 LUBRICATION

All DuroFlow blowers are splash oil lubricated at both the gear and drive ends. Oil is distributed around the gear housing and drive end chamber by the gears and specially designed oil flingers.

Approximate oil sump capacities are listed in FIGURE 3-1 below.

Series	Oil Fill Ports	Vertical Mounting	Horizontal Mounting
30	One Port - Shaft & Gear Ends Interconnected	16 oz.	28 oz.
70	One Port - Shaft End	48 oz.	123 oz.
	One Port - Gear Ends	64 oz.	160 oz.

FIGURE 3-1 - APPROXIMATE OIL SUMP CAPACITIES

RECOMMENDED LUBRICANT

The factory recommended lubricant is AEON PD Synthetic Lubricant. AEON PD is formulated especially for positive displacement blowers to provide maximum protection at any temperature. One filling of AEON PD will last a minimum of 4 times longer than a premium mineral oil, depending on actual operating conditions.

AEON PD contains a special additive package designed for greater rust and corrosion protection.

AEON PD Lubricant

Description	Part Number
1 Quart	28G23
Case/12Quarts	28G24
5 Gallon Pail	28G25
55 Gallon Drum	28G28

AEON PD Food Grade Lubricant

Description	Part Number
1 Quart	28H97
Case/12Quarts	28H98
5 Gallon Pail	28H99
55 Gallon Drum	28H100

FIGURE 3-2 - AEON PD SYNTHETIC LUBRICANT

NOTICE

Machines are shipped without oil in the sumps. Do not operate before adding lubricant.

LUBRICATION INSTRUCTIONS

For 30 series models, the oil fill port is located on the top of the blower at the driveshaft end (see FIGURE 1-2, page 5). The two oil sumps are connected by a passageway through the housing.

Add oil until the level stabilizes at the center of the sight-glass(es). Oil level at the sight glass must be established when the blower is not operating.

Add fresh oil as required to maintain proper level.

On 70 series models (units with two oil sight glasses), each end of the blower has a separate oil sump. Oil must be added to **each end** of the blower through the oil breather ports (see FIGURE 1-2, page 5).

⚠ WARNING

Failure to add oil to each end of the blower on 70 series models will result in damage to the blower.

⚠ WARNING

Do not overfill as this will tend to cause excessive heating of the gears and may damage the unit.

The 70 series "C" design version with a column gauge indicates the actual oil level during operation. The column gauge before start-up should be filled to the middle of the glass.

The oil level should be maintained at the center of the glass while the blower is not operating. Add fresh oil as required to maintain proper level.

The 70 series column sight glass needs to be assembled at the position shown in FIGURE 3-3 below. The 70 series is generally built to vertical configuration. When converting to horizontal configuration, the 1/4" tube needs to be trimmed to suit. Horizontal configurations are built at the factory upon request

AEON PD Synthetic Lubricant should be drained after 6000 hours of operation. Re-fill with fresh AEON PD oil. If mineral oil is used, perform the above oil-change maintenance every 1500 hours. Recommended service intervals are for normal blower operating conditions. Severe operating conditions may warrant more frequent oil changes. Laboratory analysis of lubricant should be used to help determine the optimum oil change interval.

For best performance and equipment protection, use AEON PD Synthetic Lubricant, which has been specifically formulated for positive displacement blowers. If you choose not to use AEON PD Synthetic Blower Lubricant, select an oil with rust and oxidation inhibitors, anti-foam additives, and the viscosities listed in FIGURE 3-4, page 13. Do not use an oil that contains EP additives.

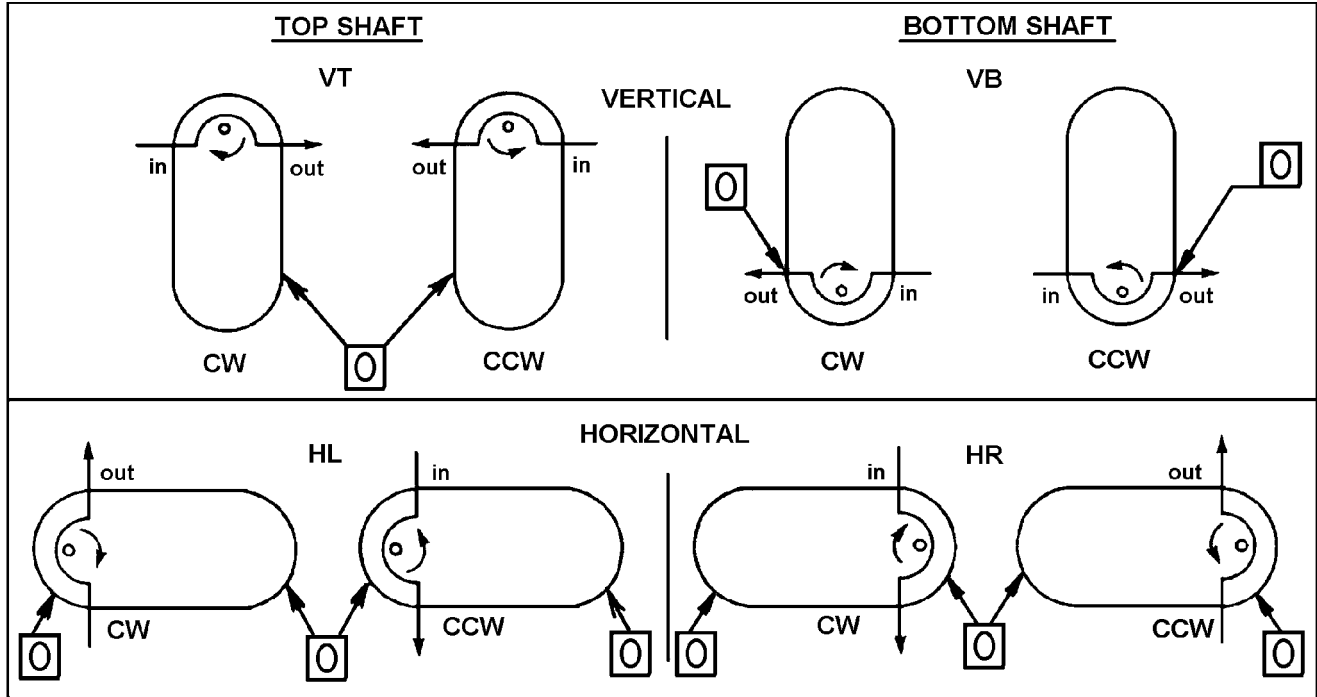

⓪ SIGHT GLASS

FIGURE 3-3 - 70 SERIES - COLUMN TYPE SIGHT GLASS LOCATION

NOTICE

Flush the oil whenever a change is made from one type of oil to another.

Flush the oil whenever a change is made from one type of oil to another. Drain the current lubricant as thoroughly as possible. Refill with the new lubricant. Fill to normal level of the blower, which is at the middle of the sight glass when the machine is not operating. Run the blower for one hour. Shut off the blower and drain the lubricant completely. Refill the blower again with the new lubricant.

Air Seal Vent Systems

All DuroFlow blowers are designed with a vent opening between the air chamber seal and the oil sump seal that vents to atmosphere any air which escapes from the air chamber.

The vent prevents pressurization of the oil sump and must be left open to atmosphere. The vent holes are tapped 3/8" NPT to permit installation of a venting line. Do not plug these vent holes (see FIGURE 1-2, page 5).

WARNING

Do not plug vent holes or oil sumps may pressurize causing loss of oil, excessive heat and serious damage to the machine.

Oil Sump Breathing System

All DuroFlow blowers are designed to permit their oil systems to breathe freely to prevent pressurization of the oil sumps. Breather filters are required to keep contaminants from entering the oil sumps (see Figure 1-1, page 4). Series 30 models require only one breather filter due to their interconnected shaft and gear end oil sumps. In these models, breathers equalize the pressure between the interconnected oil sumps and permit the equal distribution of oil between the gear and drive oil sumps. Series 70 models do not have interconnected oil sumps and require two breather filters, one on each sump.

Breather filters are easily cleaned by washing in commercial solvent and drying with compressed air. Clean at every oil change to assure proper venting.

Blower Discharge Temperature	Ambient Temperature			
	Less than 10° F *	10° F to 32° F **	32° F to 90° F	Greater than 90° F
Less than 32° F (0° C)	ISO 100 ‡	ISO 100 ‡		
32° F to 100° F (0° C to 38° C)	ISO 100 ‡	ISO 100 ‡	ISO 150 ‡	
100° F to 225° F (38° C to 105° C)	ISO 100 ‡	ISO 100 ‡	ISO 150 ‡	ISO 220 ‡
225° F to 300° F (105° C to 149° C)	ISO 150 ‡	ISO 150 ‡	ISO 220 ‡	ISO 220 ‡
Greater than 300° F (149° C)			*** ‡	*** ‡

* For ambient temperatures less than 10° F, but not less than -20° F, the use of oil sump heaters, heated enclosures or synthetic lubricant is required.

** For ambient temperatures 10° F to 32° F, the use of oil sump heaters, heated enclosures or synthetic lubricant is recommended.

*** The lubricant viscosity must be 70 SUS minimum at the lubricant operating temperature.

The pour point of the lubricant should be at least 5° to 10° F below the minimum expected ambient temperature.

For continuous operation, where the lubricant temperature exceeds 200° F, synthetic lubricant is recommended.

‡ The recommended operating range for AEON PD Synthetic Lubricant.

FIGURE 3-4 - VISCOSITY RECOMMENDATION

SECTION 4 OPERATION

Future operating problems can be avoided if proper precautions are observed when the equipment is first put into service.

Before starting under power, the blower should be turned over by hand to make certain there is no binding, or internal contact.

LIMITATIONS

Each size blower has limits on pressure differential, running speed, and discharge temperature which must not be exceeded. These limits are shown in FIGURE 4-1, page 15.



WARNING

Operating beyond the specified operating limitations will result in damage to the unit.

To accurately determine actual blower operating conditions, it is important that all pressure and temperature recordings are made directly at the ports of the blower where these conditions are at their maximum.

Relief valves **MUST** be used to protect the blower against excessive pressure or vacuum conditions. These valves should be tested at initial start up to be sure they are adjusted to relieve at 2 psi above the maximum allowable pressure or at 2" HG below the maximum allowable vacuum for the blower. Periodic testing of relief valves is suggested to assure that they are functioning.

NOTICE

Relief valves should be placed as close as possible to the blower inlet on vacuum systems or discharge on pressure systems.

Check valves must be installed on the discharge side of the blower on a pressure system and on the inlet side of the blower on a vacuum system to eliminate product ingestion resulting from autorotation and blow back during equipment shutdown.

SAFETY PRECAUTIONS

1. Do not operate the blower with an open inlet or discharge port.
2. Do not exceed specified vacuum or pressure limitations.
3. Do not operate above or below recommended blower speed range.
4. The blower is not to be used where non-sparking equipment is specified. Contact your DuroFlow Distributor for non-sparking requirements.
5. Do not operate the blower without belt guard or coupling shield properly installed.
6. Do not exceed the manufacturer's specified rim speed limit for sheaves or couplings.
7. The blower and blower discharge piping may be extremely hot and can cause skin burns on contact.
8. Do not exceed the manufacturer's certification levels for vacuum or pressure vessels.

MAXIMUM OPERATING LIMITATIONS

Size	RPM	Differential Pressure PSI	Dry * Vacuum In HG	Discharge Temperature °F
3004	4000	15	15	350
3006	4000	15	15	350
7009	2650	15	15	350
7012	2650	15	15	350
7015	2650	15	15	350
7018	2650	15	15	350
7023	2600	12	16	325
7028	2600	10	16	325

DO NOT EXCEED THESE LIMITS

* Increased vacuum levels are attainable with water injection. Contact your DuroFlow Distributor.

NOTICE

Blower speed, line losses, elevation, and increased inlet temperatures affect actual blower performance. Care must be taken to consider these factors when designing your system so that blower limitations are not exceeded.

FIGURE 4-1 - MAXIMUM OPERATING LIMITATIONS

BLOWER STARTUP CHECKLIST

This startup procedure should be followed during the initial installation and after any shutdown periods or after the blower has been worked on or moved to a new location. It is suggested that the steps be followed in sequence and checked off (✓) in the boxes provided.

- 1. Check to make certain that the blower has been properly lubricated with AEON PD Synthetic Blower Lubricant. Proper oil level cannot be overemphasized. Too little oil will ruin bearings and gears. Too much oil will overheat the lubricant and lead to serious blower damage.
- 2. Check to make sure all oil sump breather filters are installed in their proper location. Oil leakage will occur if they are improperly located.
- 3. Check the unit and all piping for foreign material and clean if required.
- 4. Check the inlet or inline filter to make sure it is not plugged causing dangerous inlet restriction.
- 5. Check the preload of the feet and the alignment of the drive. Feet that are bolted down in a bind can cause case distortion and internal rubbing. A misaligned V-belt drive will reduce belt life. Misaligned couplings place heavy loads on bearings which leads to their premature failure.
- 6. If blower is V-belt driven, check the belt tension. Over-tensioned belts create heavy bearing loads which lead to premature bearing failure.
- 7. If blower is V-belt driven, check for excessive overhung load condition. Loads in excess of maximum allowable overhung load limitations will lead to premature bearing failure and shaft breakage.
- 8. Be sure adequate drive guards are in place to protect the operator from SEVERE PERSONAL INJURY from contact with rotating components.
- 9. Turn the unit over by hand to be sure there is no binding or rotor contact. Special wear-in seals on the 30 and 70 series are utilized in DuroFlow blowers. When units are new, some resistance to turning the driveshaft by hand will be encountered. After several hours of running, this seal pressure will relieve itself and the blower will be somewhat easier to turn.
- 10. Jog the blower with the motor to check for proper rotation and airflow direction. Listen for unusual noise coming from the blower or motor and make sure the blower coasts smoothly to a stop.
- 11. Start unit and operate for 15 minutes with no load. Check for hot spots on housing or end plates, noise and other indications of interference. Allow the blower to cool to room temperature and re-check oil level. Add oil if necessary. DO NOT OVERFILL.
- 12. Check to be certain that actual blower speed is within allowable limits.
- 13. Apply load and observe operation for the first hour, checking pressure and air discharge temperature:
 - (a) Do not operate blower over manufacturer's specified pressure or vacuum rating.
 - (b) Discharge air temperature should not exceed the maximum allowable temperature.
- 14. Check and retension belts after the first few hours of operation to minimize slippage and belt wear. DO NOT OVERTENSION.
- 15. If mechanical problems are encountered during installation or start-up, notify your nearest DuroFlow Distributor. Never continue to operate your DuroFlow blower if you detect a malfunction, as serious damage can occur. **Do not attempt any internal investigation without factory authorization since this will void the warranty.**

SECTION 5 MAINTENANCE AND TROUBLESHOOTING

Your DuroFlow blower has been designed, manufactured and tested to precise specifications. Every DuroFlow blower is backed by over 70 years of proven performance in the most demanding applications that modern industry can produce. DuroFlow blowers have been designed specifically for long, trouble-free service. Minimal maintenance is required to keep your DuroFlow blower in top operating condition. Your attention to the following key points will insure years of dependable DuroFlow blower performance.

Key Points for Long Blower Life

1. Use AEON PD Synthetic Blower Lubricant to assure maximum blower protection.
2. The oil level must be checked periodically.
3. Drain and refill the blower with fresh AEON PD Lubricant every 6000 hours of operation, 1500 hours if using mineral based lubricant.
4. Clean the breather filters at every oil change or more often if dust conditions are severe.
5. Service the intake and in-line filters regularly to make sure that air flow restriction does not occur and that foreign material does not enter the blower.
6. If the blower is taken out of service for any reason, be sure to protect all interior surfaces from rusting.

TROUBLE SHOOTING

No matter how well the equipment is designed and manufactured, there may be times when servicing will be required due to normal wear, the need for adjustment, or various external causes. Whenever

equipment needs attention, the operator or service technician should be able to locate the cause and correct the trouble quickly by following the Troubleshooting Chart given below:

PROBLEM	POSSIBLE CAUSES	SOLUTION
Knocking and excessive mechanical noise.	<ol style="list-style-type: none"> 1. Unit out of time. 2. Distortion due to improper mounting or pipe strains. 3. Excessive pressure differential. 4. Worn gears. 5. Worn bearings. 	<ol style="list-style-type: none"> 1. Retime rotors. (See page 19.) 2. Check mounting alignment and relieve pipe strains. 3. Reduce to manufacturer's recommended pressure or vacuum. Examine relief valve, re-set if necessary. 4. Replace timing gears. (See page 19.) 5. Replace bearings. (See page 19.)
Excessive blower temperature.	<ol style="list-style-type: none"> 1. Too much oil in gear case. 2. Too low operating speed. 3. Plugged filter or silencer. 4. Excessive pressure differential. 5. Worn rotors clearances. 6. Internal contact. 7. Excessive inlet temperature. 	<ol style="list-style-type: none"> 1. Reduce oil level. 2. Increase blower speed. Check sheave set 3. Remove cause of obstruction. 4. Reduce pressure differential across the blower. 5. Replace rotors. (See page 19.) 6. Correct clearances. (See page 19.) 7. Relocate intake to cooler area.

PROBLEM	POSSIBLE CAUSES	SOLUTION
Rotor contact with housing or endplate.	<ol style="list-style-type: none"> 1. Insufficient assembled clearances. 2. Case or frame distortion. 3. Excessive operating pressure. 4. Excessive operating temperature. 5. Material ingestion through the blower. 	<ol style="list-style-type: none"> 1. Return for Warranty. (See page 19.) 2. Remove all mounting and pipe strains. 3. Remove cause. 4. Remove cause. 5. Replace worn inlet and inline filters. Install check valve between blower and first material load point to eliminate blow-back when blower is stopped.
Lack of CFM delivery.	<ol style="list-style-type: none"> 1. Slipping belts. 2. Worn clearances. 3. Blower RPM too slow. 	<ol style="list-style-type: none"> 1. Tighten belts. 2. Replace rotors. (See page 19.) 3. Increase Blower speed. Check sheave set.
Excessive bearing or gear wear.	<ol style="list-style-type: none"> 1. Improper lubrication. 2. Oversized belt drive, over-tightened belts. 	<ol style="list-style-type: none"> 1. Correct lubrication level. Replace dirty oil with AEON PD Synthetic Blower Lubricant. 2. Re-tension belts to proper tightness. Check drive to eliminate possible overhung load condition.
Loss of oil from seal vents.	<ol style="list-style-type: none"> 1. Worn oil seal. 2. Damaged seal sleeve. 3. Gear case or drive cover breathers plugged. 	<ol style="list-style-type: none"> 1. Replace seals. (See page 19.) 2. Replace sleeve. (See page 19.) 3. Clean breather filters.
Loss of oil from breather filters.	<ol style="list-style-type: none"> 1. Endplate seal vents plugged. 2. Worn oil seal. 	<ol style="list-style-type: none"> 1. Clean vents of obstruction. Do not plug seal vents. 2. Replace seals. (See page 19.)
Loss of oil from driveshaft seal.	<ol style="list-style-type: none"> 1. Worn oil seal. 2. Damaged seal sleeve. 	<ol style="list-style-type: none"> 1. Replace seal. (See page 19.) 2. Replace sleeve. (See page 19.)
Excessive vibration.	<ol style="list-style-type: none"> 1. Inadequate package design. 2. Soft foot. 3. Material build-up inside rotors. 4. Bearing failure. 5. Excessive gear wear. 6. Bent shaft. 7. Internal mechanical contact. 	<ol style="list-style-type: none"> 1. Reinstall base - fill with concrete. 2. Shim to eliminate condition. 3. Replace worn inlet and inline filters. Install check valve between blower and first material load point to eliminate blow-back when blower is stopped 4. Replace bearings. 5. Replace gears. 6. Replace rotor set. 7. See "Rotor Contact" above.

If you are unable to resolve the problem, contact your DuroFlow Distributor for immediate assistance.

SECTION 6 SERVICE OPTIONS

Factory Remanufactured Blower Program

STOP

You have turned to the service section because you have a blower problem that requires the blower to be mechanically adjusted or repaired. First determine if the blower is still under warranty. Contact your DuroFlow Distributor and provide them with the blower SERIAL NUMBER located on the blower name plate. DuroFlow will promptly handle all warranty claims according to the warranty policy on page 26.

If the blower is out of warranty: The DuroFlow blower is a precision machine that requires special tools and experience to be properly repaired. Before you attempt any in-house repairs on a DuroFlow blower, we recommend that you first contact your authorized DuroFlow Distributor who is factory-trained and certified to perform the following services utilizing DuroFlow parts:

- Bearing and seal replacement
- Re-time rotors and set clearances
- Clean-up following massive product ingestion

If your repair is more serious than the above procedures and involves the repair or replacement of a major blower component, you will benefit greatly by using the **DUROFLOW FACTORY REMANUFACTURED BLOWER EXCHANGE PROGRAM**. See page i for additional information.

LOOK

Look how easy it is to use the DuroFlow factory remanufactured blower program:

1. The moment you detect a major problem, simply contact your DuroFlow Distributor to order your factory remanufactured DuroFlow blower. You only need to supply the blower serial number and model number which are listed on the blower nameplate.
2. Your distributor will immediately ship a factory remanufactured blower from its inventory directly to your attention. Factory remanufactured DuroFlow blowers are backed by a full, new blower warranty . . . 18 months from the date of shipment or 12 months in service, whichever occurs first, and each remanufactured blower

incorporates all of the latest design technology and enhancements.

3. When you install your remanufactured DuroFlow unit, simply return the failed blower . . . freight collect . . . to our Indianapolis, IN Remanufacturing Center for a core credit. Your total cost for a factory remanufactured blower, after core credit, is significantly less than a new machine.

NOTICE

Inlet and discharge connectors are reusable. Remove connectors from the failed blower before returning the core to the Indianapolis, IN Remanufacturing Center.

LISTEN

Listen to the sound of your well running plant, not the complaints of your exasperated mechanics when they realize that properly repairing a DuroFlow blower is a much more delicate and difficult process than it originally appeared to be. Listen to the experience of thousands of plant operators who depend upon the DuroFlow remanufactured blower program to save them time, money and frustration. Remember, every DuroFlow factory remanufactured blower is backed with a full new blower warranty - 18 months from the date of shipment or 12 months from the date of start-up, whichever occurs first.

Repair Parts

If you elect to attempt a repair on your DuroFlow blower make certain you **use genuine DuroFlow original equipment parts** to retain the performance and dependability of your DuroFlow blower.

Factory genuine parts, engineered to original tolerances, are designed for optimum dependability . . . specifically for your blower. Design and material innovations are born from years of experience with hundreds of different blower applications. When you specify factory genuine parts you are assured of receiving parts that incorporate the most current design

advancements . . . manufactured in our state-of-the-art blower factory under exacting quality standards.

Prepackaged overhaul kits are available for immediate shipment for all DuroFlow blowers. Kits include all the normal wearing parts needed to overhaul your DuroFlow blower: Oil seals, air seals, bearings, spacers, gaskets, and Belleville timing spring. Part numbers for overhaul kits are given below.

Refer to Section 7 for additional part numbers as required.

Parts Ordering Instructions

When ordering parts, indicate the model and serial number from the blower nameplate and identify the blower configuration by referring to Figure 1-3, page 6.

For prompt, professional assistance in selecting the correct repair parts for your DuroFlow blower, contact your Duroflow Distributor who maintains a large inventory of genuine DuroFlow parts.

OVERHAUL KITS	
Model	Part Number
30 Series Overhaul Kit	
All Models with 1-Piece Housing	200GGB6010
All Models with 2-Piece Housing	DF147400
70 Series Overhaul Kit	
All Models	200GGG6010

SECTION 7
PARTS LISTS AND EXPLODED VIEWS

30 SERIES DUROFLOW BLOWER
EXPLODED VIEW

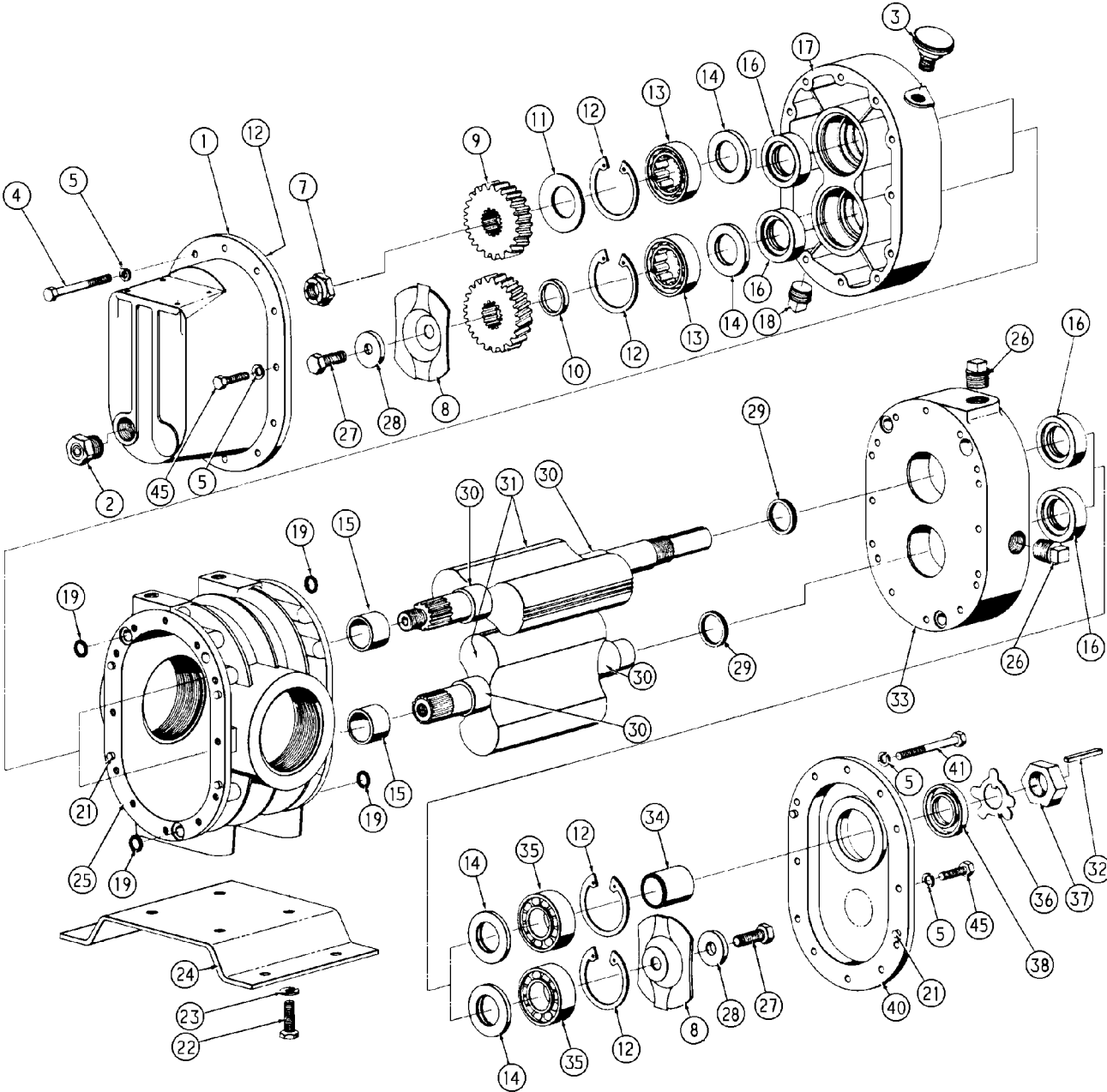

200GGB810
(Ref. Drawing)

Order by Part Number and Description. Reference Numbers are for your convenience only.

Ref. No.	Name of Part	Qty.	Size 3004 GGBA_B_ Part No.	Size 3006 GGBB_B_ Part No.
1	COVER-GEAR	1	DF145949	DF145949
2	GAUGE-SIGHT	1	40P11	40P11
3	BREATHER	1	DF140867	DF140867
4	SCREW	10	75A200	75A200
5	LOCKWASHER	24	95B2	95B2
*	6 GASKET	2	DF146038	DF146038
7	LOCKNUT	1	50V51	50V51
**	8 FLINGER	2	DF181216	DF181216
9	KIT-GEAR	1	200GGB6008	200GGB6008
10	SPACER-BEARING	1	DF182629	DF182629
*	11 SPRING-BELLEVILLE	1	DF181206	DF181206
12	RING RETAINER	4	74D68	74D68
*	13 BEARING-ROLLER	2	DF127253	DF127253
*	14 SEAL-OIL	4	DF181201	DF181201
15	BEARING SLEEVE	2	DF139787	DF139787
*	16 SEAL-LABYRINTH	4	DF184836	DF184836
17	END PLATE-GEAR END	1	DF184563	DF184563
18	PLUG	2	64AA4	64AA4
*	19 SEAL RING	4	DF185304	DF185304
***	20 BREATHER VENT	2	DF186545	DF186545
21	DOWEL	6	DF119279	DF119279
22	SCREW	4	655EE040	655EE040
23	LOCKWASHER	4	95B5	95B5
24	PLATE-VERTICAL MOUNTING	1	DF140824	200GGB247
***	BRACKET-HORIZONTAL MOUNTING	2	DF193167	DF193167
25	CYLINDER	1	DF184565	DF184593
26	PLUG	2	64A24	64A24
27	SCREW	2	655EE04N	655EE04N
28	WASHER (SPECIAL)	2	DF181207	DF181207
*	29 SHIM SET	2	200GGB732	200GGB732
30	SLEEVE	4	DF184679	DF184679
31	ROTOR GROUP	1	203GGB4028	204GGB4028
32	KEY	1	900639910305	900639910305
33	END PLATE-DRIVE END	1	DF184564	DF184564
34	SPACER-BEARING	1	DF135837	DF135837
*	35 BEARING-BALL	2	8500398	8500398
*	36 LOCKWASHERING	1	DF140892	DF140892
*	37 JAM NUT-SPECIAL	1	DF140891	DF140891
*	38 SEAL-OIL	1	60DD796	60DD796
40	COVER-DRIVE END	1	DF135807	DF135807
41	SCREW	10	75A248	75A248
46	SCREW	4	75A10	75A10
***	47 LUG-LIFTING	2	200GAA451	200GAA451
**	KIT-OVERHAUL	0	200GGB6010	200GGB6010

* Included in Overhaul Kit

** No. Req'd. and Part No. for Vertical Top and Horizontal Right hand shaft locations, for optional Vertical Bottom and Horizontal Left hand shaft locations No. Req'd. becomes (1) DF182820 and qty (1) DF143399 Flinger is added to drive end.

*** Not shown on illustration.

70 SERIES DUROFLOW BLOWER EXPLODED VIEW

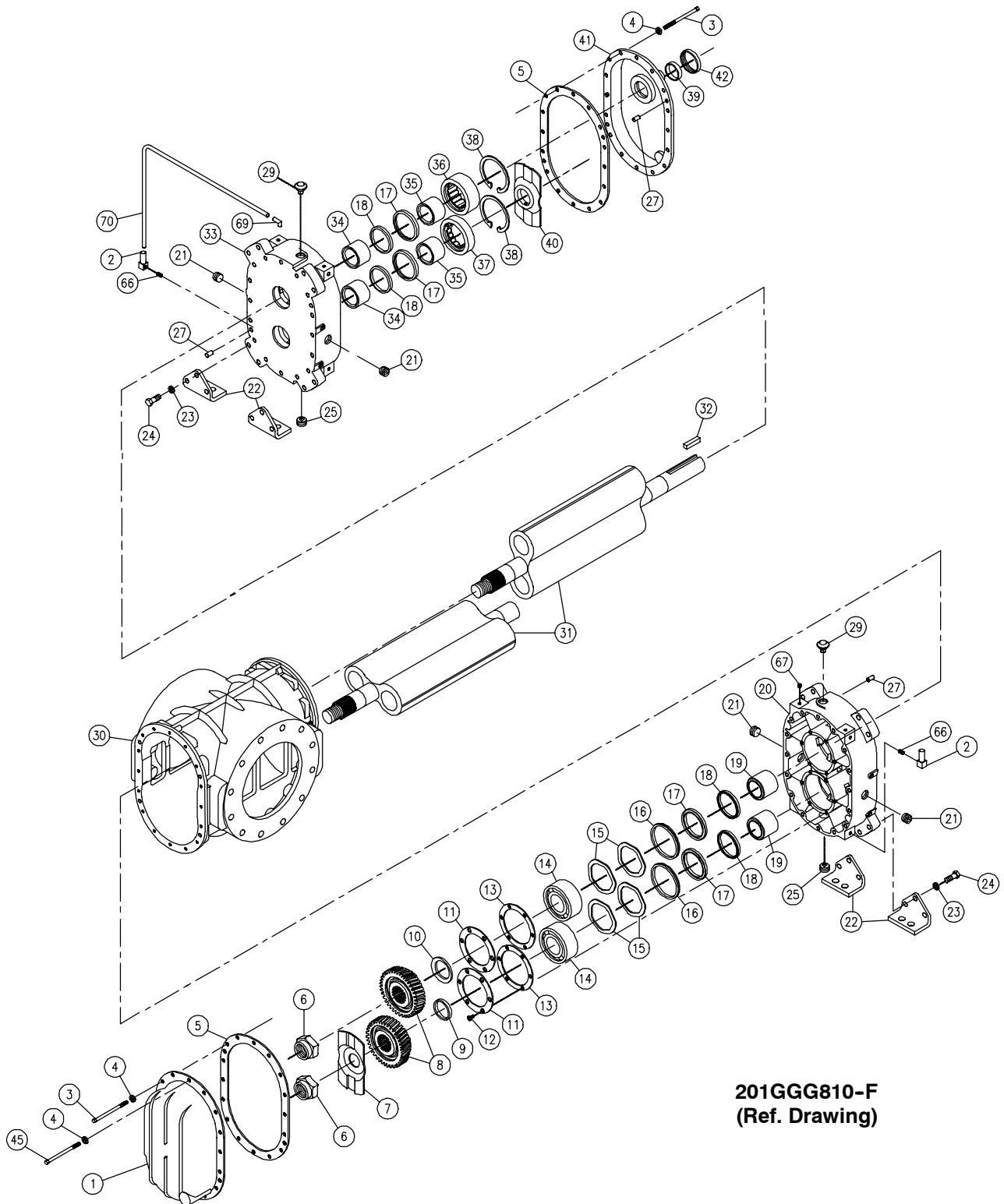

Order by Part Number and Description. Reference Numbers are for your convenience only.

Ref. No.	Name of Part	Qty.	Size 7009 GGGA_C_ Part No.	Size 7012 GGGB_C_ Part No.	Size 7015 GGGC_C_ Part No.
1	COVER-GEAR	1	300GGD602	300GGD602	300GGD602
2	GLASS-SIGHT	2	40P55	40P55	40P55
3	SCREW	30	655ED250	655ED250	655ED250
4	LOCKWASHER	32	95B3	95B3	95B3
* 5	GASKET	2	DF184031	DF184031	DF184031
6	LOCKNUT	2	DF184086	DF184086	DF184086
7	FLINGER	1	DF184024	DF184024	DF184024
8	KIT-GEAR	1	200GGG6008	200GGG6008	200GGG6008
9	SPACER	1	DF184028	DF184028	DF184028
* 10	SPRING-BELLVILLE	1	DF184030	DF184030	DF184030
11	RETAINER-BEARING	2	DF184019	DF184019	DF184019
12	SCREW	12	75LM214	75LM214	75LM214
* 13	SHIM SET	2	200GGG732	200GGG732	200GGG732
* 14	BEARING	2	DF184085	DF184085	DF184085
15	WASHER-WAVY SPRING	4	8508481	8508481	8508481
16	SPACER-BEARING	2	DF185556	DF185556	DF185556
* 17	SEAL-OIL	4	DF184084	DF184084	DF184084
* 18	SEAL-LABYRINTH	4	DF184838	DF184838	DF184838
+ 19	SPACER (GEAR END)	2	DF189049	DF189049	DF189049
20	HOUSING-BEARING	1	301GGG006	301GGG006	301GGG006
21	PLUG	4	64AC4	64AC4	64AC4
22	PLATE-MOUNTING	4	DF184949	DF184949	DF184949
23	LOCKWASHER	8	95B7	95B7	95B7
24	SCREW	8	655EF080	655EF080	655EF080
25	PLUG-MAGNETIC	2	64BJ3	64BJ3	64BJ3
27	PIN-DOWEL	6	62M82	62M82	62M82
29	BREATHER	2	5L223	5L223	5L223
30	CYLINDER	1	DF189510	DF189511	DF189512
31	ROTOR GROUP	1	206GGG4028	207GGG4028	208GGG4028
32	KEY-SQUARE	1	2800T17	2800T17	2800T17
33	HOUSING-BEARING	1	300GGG006	300GGG006	300GGG006
+ 34	SPACER (DRIVE END)	2	DF189050	DF189050	DF189050
*+ 35	BEARING-INNER RACE	2	DF194012	DF194012	DF194012
* 36	BEARING-ROLLER	1	DF194014	DF194014	DF194014
* 37	BEARING-ROLLER	1	DF194011	DF194011	DF194011
38	RING-RETAINING	2	74D83	74D83	74D83
*++ 39	SLEEVE-WEAR	1	80L6	80L6	80L6
40	FLINGER ASSEMBLY	1	DF189541	DF189541	DF189541
** 41	COVER-DRIVE	1	300GGD477	300GGD477	300GGD477
* 42	SEAL-OIL	1	60DD709	60DD709	60DD709
45	SCREW	2	655ED25D	655ED25D	655ED25D
66	NIPPLE	2	63C4G	63C4G	63C4G
67	PLUG	14	64B14	64B14	64B14
69	ELBOW-TUBE - 90°	2	86E59	86E59	86E59
70	TUBE	3.0 FT.	85E4A	85E4A	85E4A
* 71	KIT-OVERHAUL	0	200GGG6010	200GGG6010	200GGG6010

* Included in Overhaul Kit.

** For Vertical Top and Horizontal Left hand shaft locations, for optional Vertical Bottom and Horizontal Right hand shaft locations use Part No. DF191446.

+ Included with Group-Rotor - Ref. No. 31.

++ Install with Loctite 620 Compound.

Order by Part Number and Description. Reference Numbers are for your convenience only.

Ref. No.	Name of Part	Qty.	Size 7018 GGGD_C_ Part No.	Size 7023 GGGE_C_ Part No.	Size 7028 GGGF_C_ Part No.
1	COVER-GEAR	1	300GGG602	300GGG602	300GGG602
2	GLASS-SIGHT	2	40P55	40P55	40P55
3	SCREW	30	655ED250	655ED250	655ED250
4	LOCKWASHER	32	95B3	95B3	95B3
* 5	GASKET	2	DF184031	DF184031	DF184031
6	LOCKNUT	2	DF184086	DF184086	DF184086
7	FLINGER	1	DF184024	DF184024	DF184024
8	KIT-GEAR	1	200GGG6008	200GGG6008	200GGG6008
9	SPACER	1	DF184028	DF184028	DF184028
* 10	SPRING-BELLVILLE	1	DF184030	DF184030	DF184030
11	RETAINER-BEARING	2	DF184019	DF184019	DF184019
12	SCREW	12	75LM214	75LM214	75LM214
* 13	SHIM SET	2	200GGG732	200GGG732	200GGG732
* 14	BEARING	2	DF184085	DF184085	DF184085
15	WASHER-WAVY SPRING	4	8508481	8508481	8508481
16	SPACER-BEARING	2	DF185556	DF185556	DF185556
* 17	SEAL-OIL	4	DF184084	DF184084	DF184084
* 18	SEAL-LABYRINTH	4	DF184838	DF184838	DF184838
+ 19	SPACER (GEAR END)	2	DF189049	DF189049	DF189049
20	HOUSING-BEARING	1	301GGG006	301GGG006	301GGG006
21	PLUG	4	64AC4	64AC4	64AC4
22	PLATE-MOUNTING	4	DF184949	DF184949	DF184949
23	LOCKWASHER	8	95B7	95B7	95B7
24	SCREW	8	655EF080	655EF080	655EF080
25	PLUG-MAGNETIC	2	64BJ3	64BJ3	64BJ3
27	PIN-DOWEL	6	62M82	62M82	62M82
29	BREATHER	2	5L223	5L223	5L223
30	CYLINDER	1	DF189513	201GGG002	200GGG002
31	ROTOR GROUP	1	209GGG4028	210GGG4028	211GGG4028
32	KEY-SQUARE	1	2800T17	2800T17	2800T17
33	HOUSING-BEARING	1	300GGG006	300GGG006	300GGG006
+ 34	SPACER (DRIVE END)	2	DF189050	DF189050	DF189050
*+ 35	BEARING-INNER RACE	2	DF194012	DF194012	DF194012
* 36	BEARING-ROLLER	1	DF194014	DF194014	DF194014
* 37	BEARING-ROLLER	1	DF194011	DF194011	DF194011
38	RING-RETAINING	2	74D83	74D83	74D83
*++ 39	SLEEVE-WEAR	1	80L6	80L6	80L6
40	FLINGER ASSEMBLY	1	DF189541	DF189541	DF189541
** 41	COVER-DRIVE	1	300GGD477	300GGD477	300GGD477
* 42	SEAL-OIL	1	60DD709	60DD709	60DD709
45	SCREW	2	655ED25D	655ED25D	655ED25D
66	NIPPLE	2	63C4G	63C4G	63C4G
67	PLUG	14	64B14	64B14	64B14
69	ELBOW-TUBE - 90°	2	86E59	86E59	86E59
70	TUBE	3.0 FT.	85E4A	85E4A	85E4A
* 71	KIT-OVERHAUL	0	200GGG6010	200GGG6010	200GGG6010

* Included in Overhaul Kit.

** For Vertical Top and Horizontal Left hand shaft locations, for optional Vertical Bottom and Horizontal Right hand shaft locations use Part No. DF191446.

+ Included with Group-Rotor - Ref. No. 31.

++ Install with Loctite 620 Compound.

DUROFLOW BLOWERS**30 SERIES****70 SERIES****GENERAL PROVISIONS AND LIMITATIONS**

Gardner Denver (the "Company") warrants to each original retail purchaser ("Purchaser") of its new products from the Company or its authorized distributor that such products are, at the time of delivery to the Purchaser, made with good material and workmanship. No warranty is made with respect to:

1. Any product which has been repaired or altered in such a way, in the Company's judgment, as to affect the product adversely.
2. Any product which has, in the Company's judgment been subject to negligence, accident, improper storage, or improper installation or application.
3. Any product which has not been operated or maintained in accordance with normal practice and with the recommendations of the Company.
4. Components or accessories manufactured, warranted and serviced by others.
5. Any reconditioned or prior owned product.

Claims for items described in (4) above should be submitted directly to the manufacturer.

WARRANTY PERIOD

The Company's obligation under this warranty is limited to repairing or, at its option, replacing, during normal business hours at an authorized service facility of the Company, any part which in its judgment proved not to be as warranted within the applicable Warranty Period as follows.

BARE BLOWERS

Basic bare blowers, consisting of all parts within, are warranted for 12 months from date of initial use or 18 months from date of shipment to the first purchaser, whichever occurs first.

Any disassembly or partial disassembly of the blower, or failure to return the "unopened" blower per Company instructions, will be cause for denial of warranty.

OTHER COMPONENTS

All other components are warranted for 12 months from date of initial use or 18 months from date of shipment to first purchaser, whichever comes first.

LABOR TRANSPORTATION AND INSPECTION

The Company will provide labor, by Company representative or authorized service personnel, for repair or replacement of any product or part thereof which in the

Company's judgment is proved not to be as warranted. Labor shall be limited to the amount specified in the Company's labor rate schedule.

Labor costs in excess of the Company rate schedule amounts or labor provided by unauthorized service personnel is not provided for by this warranty.

All costs of transportation of product, labor or parts claimed not to be as warranted and, of repaired or replacement parts to or from such service facilities shall be borne by the Purchaser. The Company may require the return of any part claimed not to be as warranted to one of its facilities as designated by Company, transportation prepaid by Purchaser, to establish a claim under this warranty.

Replacement parts provided under the terms of the warranty are warranted for the remainder of the Warranty Period of the product upon which installed to the same extent as if such parts were original components thereof.

DISCLAIMER

THE FOREGOING WARRANTY IS EXCLUSIVE AND IT IS EXPRESSLY AGREED THAT, EXCEPT AS TO TITLE, THE COMPANY MAKES NO OTHER WARRANTIES, EXPRESSED, IMPLIED OR STATUTORY, INCLUDING ANY IMPLIED WARRANTY OF MERCHANTABILITY.

THE REMEDY PROVIDED UNDER THIS WARRANTY SHALL BE THE SOLE, EXCLUSIVE AND ONLY REMEDY AVAILABLE TO PURCHASER AND IN NO CASE SHALL THE COMPANY BE SUBJECT TO ANY OTHER OBLIGATIONS OR LIABILITIES. UNDER NO CIRCUMSTANCES SHALL THE COMPANY BE LIABLE FOR SPECIAL, INDIRECT, INCIDENTAL OR CONSEQUENTIAL DAMAGES, EXPENSES, LOSSES OR DELAYS HOWSOEVER CAUSED.

No statement, representation, agreement, or understanding, oral or written, made by any agent, distributor, representative, or employee of the Company which is not contained in this Warranty will be binding upon the Company unless made in writing and executed by an officer of the Company.

This warranty shall not be effective as to any claim which is not presented within 30 days after the date upon which the product is claimed not to have been as warranted. Any action for breach of this warranty must be commenced within one year after the date upon which the cause of action occurred.

Any adjustment made pursuant to this warranty shall not be construed as an admission by the Company that any product was not as warranted.

Warranty Registration

Your DuroFlow blower has been designed and manufactured to provide continuous, trouble-free service, year in and year out.

Follow the simple maintenance procedures outlined in this manual and you will be assured of superior blower performance and years of dependable blower life.

Please register your DuroFlow Blower with our Factory Service & Warranty Department. Complete the warranty registration information below and fax it to Gardner Denver.

Thanks again for the privilege of serving you with quality from DuroFlow.

Date:

Your Name:

Your Title:

Your Company:

Address:

City, State, Zip:

Telephone:

Blower Serial Number:

Date of Blower Start-up:

What is your application:

Gardner
Denver

For additional information, contact your local representative or

Gardner Denver Compressor Division

1800 Gardner Expressway, Quincy, Illinois 62305

Phone (800) 682-9868 • Fax (217) 221-8780

E-mail: pd.blowers@gardnerdenver.com

Visit our web site: www.gardnerdenver.com

Sales and Service in all major cities

