



# EurusBlower

Please read this service manual carefully before installation and operation.

## Rotary Blower Service Manual

**Models: ZZ2M,ZZ3M,ZZ4M,ZZ5MA,ZZ6M,ZZ7M  
ZZ2L,ZZ3L,ZZ4L,ZZ5LA,ZZ6L,ZZ7L**



Sunco Powder Systems, Inc.  
Blower Division  
Phone: 704-545-3922  
[www.suncoblowers.com](http://www.suncoblowers.com)

2/2012



## Table of Contents

|  |           |
|--|-----------|
| <b>1. SUMMARY .....</b>  | <b>4</b>  |
| <b>2. FOREWORD.....</b>  | <b>5</b>  |
| <b>3. SAFETY PRECAUTIONS .....</b>                                   | <b>6</b>  |
| <b>4. TECHNICAL SPECIFICATIONS .....</b>                             | <b>7</b>  |
| <b>4.1. ROTARY BLOWER SPECIFICATIONS .....</b>                       | <b>7</b>  |
| <b>4.2. AMBIENT TEMPERATURES .....</b>                               | <b>8</b>  |
| <b>4.3. MAXIMUM ALLOWABLE OVERHUNG LOAD (OHL) .....</b>              | <b>9</b>  |
| <b>4.4. OIL CAPACITIES .....</b>                                     | <b>10</b> |
| <b>4.5. RECOMMENDED LUBRICANT .....</b>                              | <b>11</b> |
| <b>4.6. NAMEPLATE .....</b>  | <b>11</b> |
| <b>4.7. DIMENSIONAL DRAWINGS .....</b>                               | <b>12</b> |
| <b>4.8. PERFORMANCE CURVES.....</b>                                  | <b>12</b> |
| <b>4.9. PERFORMANCE TABLES .....</b>                                 | <b>12</b> |
| <b>5. SAFETY INSTRUCTIONS.....</b>                                   | <b>12</b> |
| <b>5.1. WARNING SYMBOLS .....</b>                                    | <b>12</b> |
| <b>5.2 SAFETY WARNING AND REGULATIONS (OSHA CFR 29, 19100).....</b>  | <b>13</b> |
| <b>5.3 GENERAL REFERENCES.....</b>                                   | <b>14</b> |
| <b>6. ARRIVAL AND USE OF THE ROTARY BLOWER.....</b>                  | <b>14</b> |
| <b>6.1 ARRIVAL INSPECTION .....</b>                                  | <b>14</b> |
| <b>6.2 PROPER USE OF THE ROTARY BLOWER.....</b>                      | <b>15</b> |
| <b>7. MOVING AND HANDLING .....</b>                                  | <b>15</b> |
| <b>7.1 HANDLING INSTRUCTIONS .....</b>                               | <b>15</b> |
| <b>7.2 HANDLING WITH A FORKLIFT OR PALLET JACK .....</b>             | <b>15</b> |
| <b>7.3 HANDLING WITH A CRANE HOOK .....</b>                          | <b>16</b> |
| <b>7.4. STORAGE.....</b>   | <b>16</b> |
| 7.4.1 <i>Temporary Storage.....</i>                                  | <i>16</i> |
| 7.4.2. <i>Storage for longer than one year .....</i>                 | <i>16</i> |
| 7.4.3. <i>Recommended Oils for Storage.....</i>                      | <i>17</i> |
| 7.4.4. <i>Operating after long-term storage.....</i>                 | <i>17</i> |
| <b>8. OPERATIONAL CHARACTERISTICS AND CONSTRUCTION .....</b>         | <b>17</b> |
| <b>8.1 OPERATIONAL CHARACTERISTICS .....</b>                         | <b>17</b> |
| <b>8.2 CONSTRUCTION .....</b>  | <b>18</b> |
| <b>8.3 HORIZONTAL FLOW CONFIGURATION.....</b>                        | <b>19</b> |
| <b>8.4 VERTICAL FLOW CONFIGURATION.....</b>                          | <b>19</b> |
| <b>8.5 SHAFT DIAMETER AND OIL DRAIN (OIL FILL) PLUG THREAD .....</b> | <b>20</b> |
| <b>9. INSTALLATION AND DESIGN REQUIREMENTS .....</b>                 | <b>20</b> |



---

|  |           |
|--|-----------|
| <b>9.1. INSTALLATION REQUIREMENTS</b> .....                      | <b>20</b> |
| <b>9.2 MOUNTING CONFIGURATIONS</b> .....                         | <b>21</b> |
| <b>9.3. DRIVE MOTOR</b> .....                                    | <b>22</b> |
| 9.3.1. <i>Direct coupled drive with flexible coupling</i> .....  | 23        |
| 9.3.2. <i>V-belt drive</i> .....                                 | 23        |
| <b>9.4. SYSTEM SAFETY EQUIPMENT</b> .....                        | <b>24</b> |
| 9.4.1. <i>Safety relief valve</i> .....                          | 24        |
| 9.4.2 <i>Check valve</i> .....                                   | 25        |
| 9.4.3 <i>Visual Indicators of Temperature and Pressure</i> ..... | 26        |
| 9.4.4 <i>Monitoring Device switches</i> .....                    | 26        |
| 9.4.5. <i>Noise reduction</i> .....                              | 26        |
| <b>10. OPERATING A ROTARY BLOWER</b> .....                       | <b>27</b> |
| <b>10.1. PRIOR TO STARTING UNIT FOR FIRST TIME</b> .....         | <b>27</b> |
| <b>10.2. STARTING AND STOPPING THE ROTARY BLOWER</b> .....       | <b>29</b> |
| <b>10.3. TROUBLE SHOOTING</b> .....                              | <b>29</b> |
| 10.3.1 <i>Trouble Shooting Guide</i> .....                       | 30        |
| <b>11. MAINTENANCE</b> .....                                     | <b>31</b> |
| <b>11.1 RULES FOR MAINTENANCE</b> .....                          | <b>31</b> |
| <b>11.2. REGULAR MAINTENANCE SCHEDULE</b> .....                  | <b>31</b> |
| <b>11.3 OIL LEVEL CHECK</b> .....                                | <b>32</b> |
| <b>11.4 LUBRICATING OIL/GREASE CHANGE</b> .....                  | <b>33</b> |
| <b>12. SPARE PARTS AND AFTER SALES</b> .....                     | <b>34</b> |
| <b>13. MAINTENANCE SCHEDULE SHEET</b> .....                      | <b>52</b> |



## 1. SUMMARY

Before installation and operation, read this Service Manual carefully

Check package for damage. If found file claim with carrier and notify EURUS.

Must be carefully when operating rotary blowers, see *Safety Instructions*

Make sure both driving and driven equipment is correctly lubricated before start-up, see *Oil Capacities and Recommended Lubricant*.

In event of trouble during installation or operation, do not attempt repairs of blower. Notify Eurus, giving all nameplate information, Will received a technical service. See *Operating a Rotary Blower*

Before install the blower, See *Installation and Design Requirements*.

Store the rotary blower in a dry, covered space, see *Storage*.

Always operate rotary blowers in a dry and dust free environment, See *Operational Characteristics and Construction*.



## 2. FOREWORD

ZZ Series blowers are the result of advanced engineering and skilled manufacturing. To be assured of receiving maximum service from this machine, the owner must exercise care in its operation and maintenance. This manual is written to give the operator and maintenance department essential information for day-to-day operation, maintenance and adjustment. Careful adherence to these instructions will result in economical operation and minimum downtime.



Danger is used to indicate the presence of a hazard which will cause severe personal injury, death, or substantial damage if the warning is ignored.



Warning is used to indicate the presence of a hazard which can cause severe personal injury, death, or substantial damage if the warning is ignored.



Caution is used to indicate the presence of a hazard which will or can cause minor personal injury or property damage if the warning is ignored.

### NOTICE

Notice is used to notify people of installation, operation or maintenance information which is important but not hazard-related.



## 3. SAFETY PRECAUTIONS

Safety is everybody's business and is based on your use of good common sense. All situations or circumstances cannot always be predicated and covered by established rules. Therefore, use your past experience, which out for safety hazards and be cautious. Some general safety precautions are given below.



Failure to observe these notices could result in injury to or death of personnel

- **Keep fingers and clothing away** from revolving fan, drive coupling, etc.
- **Do not use the air discharge** from this unit for breathing-not suitable for human consumption.
- **Do not loose or remove** the oil filler plug, drain plugs, covers or break any connections, etc., in the blower air or oil system until the until the is shut down and the air pressure has been relieved.
- **Electrical shock** can and may be fatal.
- **Blower unit must be grounded** in accordance with the National Electrical Code. A ground jumper equal to the size of the equipment ground conductor must be used to connect the blower motor base to the unit base.
- **Open main disconnect switch,** tag and lockout before working on the control.
- **Disconnect the blower** from its power source, tag and lockout before working on the control.



Failure to observe these notices could result in damage to equipment

- **Stop the unit** if any repairs or adjustments on or around the blower are required.
- **Disconnect the blower** from its power source, tag and lockout before working on the unit-this machine maybe automatically controlled and may start at any time.
- **Do not exceed** the rated maximum speed shown on the nameplate
- **Do not operate unit** if safety devices are not operating properly. Check periodically. Never bypass safety devices.



## 4. Technical Specifications

### 4.1. Rotary Blower Specifications

|  | ZZ2M                                      | ZZ3M             | ZZ4M              | ZZ5MA             | ZZ6M              | ZZ7M              |
|--|---|------------------|-------------------|-------------------|-------------------|-------------------|
| <b>Configuration</b> <sup>1</sup>  |   |                  |                   |                   |                   |                   |
|  | Vertical or Horizontal Flow Configuration |                  |                   |                   |                   |                   |
| <b>Direction of Rotation</b> <sup>1</sup>  |   |                  |                   |                   |                   |                   |
|  | CW or CCW                                 |                  |                   |                   |                   |                   |
| <b>Inlet CFM</b> <sup>2, 5</sup> (@maximum speed and maximum $\Delta p$ )              |   |                  |                   |                   |                   |                   |
|  | 73  | 159              | 346               | 481               | 751               | 1316              |
| <b>Power Consumption</b> <sup>3, 5</sup> (BHP @ maximum speed and maximum $\Delta p$ ) |   |                  |                   |                   |                   |                   |
| Blower   | 6.2<br>(12 psi)                           | 12.2<br>(12 psi) | 19.8<br>(10 psi)  | 35.7<br>(13 psi)  | 59.8<br>(14 psi)  | 70.9<br>(10 psi)  |
| Vacuum   | 3.8<br>(15 InHg)                          | 7.5<br>(15 InHg) | 15.7<br>(16 InHg) | 21.6<br>(16 InHg) | 35.3<br>(16 InHg) | 56.8<br>(16 InHg) |
| <b>Operating Limits</b>  |   |                  |                   |                   |                   |                   |
| Max RPM  | 5275                                      | 3600             | 3600              | 2850              | 2350              | 2050              |
| Max Case Pressure,   | 25 (psig)                                 |                  |                   |                   |                   |                   |
| Max $\Delta p$ Blower <sup>4,5</sup> (psi)   | 12  | 12               | 10                | 13                | 14                | 10                |
| Max $\Delta p$ Vacuum <sup>4,5</sup> (InHg)  | 15  | 15               | 16                | 16                | 16                | 16                |
| Max Pressure Ratio <sup>4</sup>  | 2:1                                       | 2:1              | 2.15:1            | 2.15:1            | 2.15:1            | 2.15:1            |
| Max Discharge Temp. °F   | 313                                       | 287              | 290               | 285               | 308               | 288               |
| Max Inlet Temp. °F   | 104                                       |                  |                   |                   |                   |                   |
| <b>Connection</b>  |   |                  |                   |                   |                   |                   |
| Inlet Port (ANSI)  | NPT 1"                                    | NPT 2"           | NPT 2.5"          | NPT 4"            | 5"                | 6"                |
| Discharge Port (ANSI)  |   |                  |                   |                   |                   |                   |
| <b>Weight (lb)</b>   |   |                  |                   |                   |                   |                   |
|  | 48  | 88               | 132               | 217               | 364               | 684               |

|   | ZZ2L                                      | ZZ3L | ZZ4L | ZZ5LA | ZZ6L | ZZ7L |
|---|---|------|------|-------|------|------|
| <b>Configuration</b> <sup>1</sup>         |   |      |      |       |      |      |
|   | Vertical or Horizontal Flow Configuration |      |      |       |      |      |
| <b>Direction of Rotation</b> <sup>1</sup> |   |      |      |       |      |      |



|   |                |                   |                 |                   |                   |                   |
|---|----------------|-------------------|-----------------|-------------------|-------------------|-------------------|
|   | CW or CCW      |                   |                 |                   |                   |                   |
| <b>Inlet CFM<sup>2, 5</sup></b> (@maximum speed and maximum $\Delta p$ )              |                |                   |                 |                   |                   |                   |
|   | 176            | 311               | 527             | 862               | 1521              | 2242              |
| <b>Power Consumption<sup>3, 5</sup></b> (BHP @ maximum speed and maximum $\Delta p$ ) |                |                   |                 |                   |                   |                   |
| Blower  | 7.1<br>(7 psi) | 12.5<br>(7 psi)   | 20.4<br>(7 psi) | 32.3<br>(7 psi)   | 58.7<br>(7 psi)   | 72.7<br>(7 psi)   |
| Vacuum  | 7<br>(14 InHg) | 12.2<br>(14 InHg) | 20<br>(14 InHg) | 31.6<br>(14 InHg) | 57.8<br>(14 InHg) | 12.2<br>(14 InHg) |
| <b>Operating Limits</b>   |                |                   |                 |                   |                   |                   |
| Max RPM   | 5275           | 3600              | 3600            | 2850              | 2350              | 2050              |
| Max Case Pressure,  | 25 (psig)      |                   |                 |                   |                   |                   |
| Max $\Delta p$ Blower <sup>4,5</sup> (psi)  | 7              | 7                 | 7               | 7                 | 7                 | 7                 |
| Max $\Delta p$ Vacuum <sup>4,5</sup> (InHg)   | 12             | 14                | 14              | 14                | 14                | 14                |
| Max Pressure Ratio <sup>4</sup>   | 1.88:1         | 1.88:1            | 1.88:1          | 1.88:1            | 1.88:1            | 1.88:1            |
| Max Discharge Temp. °F  | 238            | 248               | 239             | 239               | 248               | 198               |
| Max Inlet Temp. °F  | 104            |                   |                 |                   |                   |                   |
| <b>Connection</b>   |                |                   |                 |                   |                   |                   |
| Inlet Port (ANSI)   | NPT 2"         | NPT 2.5"          | NPT 3"          | NPT 4"            | 6"                | 8"                |
| Discharge Port (ANSI)   |                |                   |                 |                   |                   |                   |
| <b>Weight (lb)</b>  |                |                   |                 |                   |                   |                   |
|   | 60             | 111               | 162             | 285               | 529               | 838               |

- Notes:
1. The user can select the configuration according to their installation requirements.
  2. The effective volume flow is dependent on the speed and the differential pressure.
  3. The power consumption is dependent upon the operating point required, e.g. volume-flow and differential pressure.
  4. The ratings based on inlet air at standard pressure of 14.7 psia, standard temperature of 68 degrees F, and specific gravity of 1.0.
  5.  $\Delta p$  = discharge pressure – inlet pressure

## 4.2. Ambient Temperatures

Minimum ambient temperature \*..... 5 °F  
 Maximum ambient temperature \*..... 104 °F

\* These temperature limits are based on lubricants specified here within. Consult Eurus Blower for recommendations if operating environment temperatures exceed limits (see





lubricant recommendations, section 4.5).

### 4.3. Maximum Allowable Overhung Load (OHL)

#### ARC OF CONTACT FACTORS

| MODEL       | Gear Diameter (Inches) | DUAL SPLASH LUBE Dimensions (Inches) |      |      | Maximum Allowable Moment(LB-IN) |
|-------------|------------------------|--------------------------------------|------|------|---------------------------------|
|             |                        | A                                    | B    | C    |                                 |
| ZZ2M/ZZ2L   | 2.76                   | 2.78                                 | 0.87 | 0.25 | 150                             |
| ZZ3M/ZZ3L   | 3.54                   | 2.90                                 | 0.94 | 0.25 | 390                             |
| ZZ4M/ZZ4L   | 4.04                   | 3.63                                 | 1.26 | 0.3  | 500                             |
| ZZ5MA/ZZ5LA | 5.08                   | 4.09                                 | 1.57 | 0.3  | 1280                            |
| ZZ6M/ZZ6L   | 5.98                   | 4.51                                 | 1.57 | 0.38 | 1800                            |
| ZZ7M/ZZ7L   | 7.09                   | 4.95                                 | 1.68 | 0.38 | 3000                            |

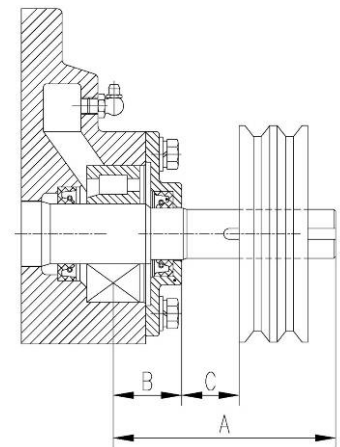

|       |       |       |       |       |       |       |       |       |       |       |       |
|-------|-------|-------|-------|-------|-------|-------|-------|-------|-------|-------|-------|
| Z     | Ac    | Z     | Ac    | Z     | Ac    | Z     | Ac    | Z     | Ac    | Z     | Ac    |
| 0.000 | 1.000 | 0.250 | 0.966 | 0.500 | 0.926 | 0.750 | 0.879 | 1.000 | 0.823 | 1.250 | 0.751 |
| 0.025 | 0.997 | 0.275 | 0.962 | 0.525 | 0.922 | 0.775 | 0.874 | 1.025 | 0.816 | 1.275 | 0.742 |
| 0.050 | 0.994 | 0.300 | 0.958 | 0.550 | 0.917 | 0.800 | 0.869 | 1.050 | 0.810 | 1.300 | 0.734 |
| 0.075 | 0.990 | 0.325 | 0.954 | 0.575 | 0.913 | 0.825 | 0.864 | 1.075 | 0.803 | 1.325 | 0.725 |
| 0.100 | 0.987 | 0.350 | 0.951 | 0.600 | 0.908 | 0.850 | 0.858 | 1.100 | 0.796 | 1.350 | 0.716 |
| 0.125 | 0.983 | 0.375 | 0.947 | 0.625 | 0.904 | 0.875 | 0.852 | 1.125 | 0.789 | 1.375 | 0.706 |
| 0.150 | 0.980 | 0.400 | 0.943 | 0.650 | 0.899 | 0.900 | 0.847 | 1.150 | 0.782 | 1.400 | 0.697 |
| 0.175 | 0.977 | 0.425 | 0.939 | 0.675 | 0.894 | 0.925 | 0.841 | 1.175 | 0.774 | 1.425 | 0.687 |
| 0.200 | 0.973 | 0.450 | 0.935 | 0.700 | 0.889 | 0.950 | 0.835 | 1.200 | 0.767 |       |       |
| 0.225 | 0.969 | 0.475 | 0.930 | 0.725 | 0.884 | 0.975 | 0.829 | 1.225 | 0.759 |       |       |



## CALCULATION OF BELT PULL

$$\text{Belt Pull} = \left[ \frac{2.5 - AC}{AC} \right] \times \left[ \frac{125954 \times Hp \times S.F.}{D \times RPM} \right]$$

**Key:**

**Ac** = Arc of Contact Factor (Refer to Arc of Contact Factor Chart above)  
**Hp** = Blower Horsepower for Operating Conditions  
**S.F.** = Actual Drive Service Factor  
**D** = Blower Sheave Pitch Diameter in Inches  
**RPM** = Blower Sheave Speed

$$Z = \left[ \frac{\text{Large Sheave Pitch Diameter (in)} - \text{Small Sheave Pitch Diameter (in)}}{\text{Sheave Center Distance (in)}} \right]$$

## CALCULATION OF SHAFT MOMENT

$$\text{Shaft Moment (LB-IN)} = \text{Belt Pull} \times \left[ B + C + \left( \frac{\text{Sheave Width}}{2} \right) \right]$$

### 4.4. Oil Capacities

At the gear end, the timing gear teeth are lubricated by being partially submerged in oil. The gear teeth

| Model     | Gear Diameter(in) | Horizontal Flow Configuration |                 | Vertical Flow Configuration |                 |
|-----------|-------------------|-------------------------------|-----------------|-----------------------------|-----------------|
|           |                   | Gear End                      | Drive End *     | Gear End                    | Drive End *     |
| ZZ2M (L)  | 2.76              | 1.83 OZ                       | Grease 1.3 OZ   | 4.59 OZ                     | Grease 1.3 OZ   |
| ZZ3M (L)  | 3.54              | 4.03 OZ                       | Grease 1.48 OZ  | 11.44 OZ                    | Grease 1.48 OZ  |
| ZZ4M (L)  | 4.04              | 6.70 OZ                       | Grease 1.67 OZ  | 15.15 OZ                    | Grease 1.67 OZ  |
| ZZ5MA(LA) | 5.08              | 14.83 OZ                      | Grease 2.37 OZ  | 36.41 OZ                    | Grease 2.37 OZ  |
| ZZ6M (L)  | 5.98              | 28.67 OZ                      | Grease 11.23 OZ | 65.22 OZ                    | Grease 11.23 OZ |
| ZZ7M (L)  | 7.09              | 68.86 OZ                      | Grease 16.69 OZ | 128.01 OZ                   | Grease 16.69 OZ |

serve as oil slingers for gear end bearings.

Drive end bearings are grease lubricated at the factory with Lithium Complex based grease.

\*Reference Value



## 4.5. Recommended Lubricant

Use the appropriate grade and viscosity of industrial type, non-detergent, rust inhibiting, anti-foaming oil (Reference Chart 1 below). The correct oil depends on the range of ambient temperatures as well as the range of discharge temperatures.

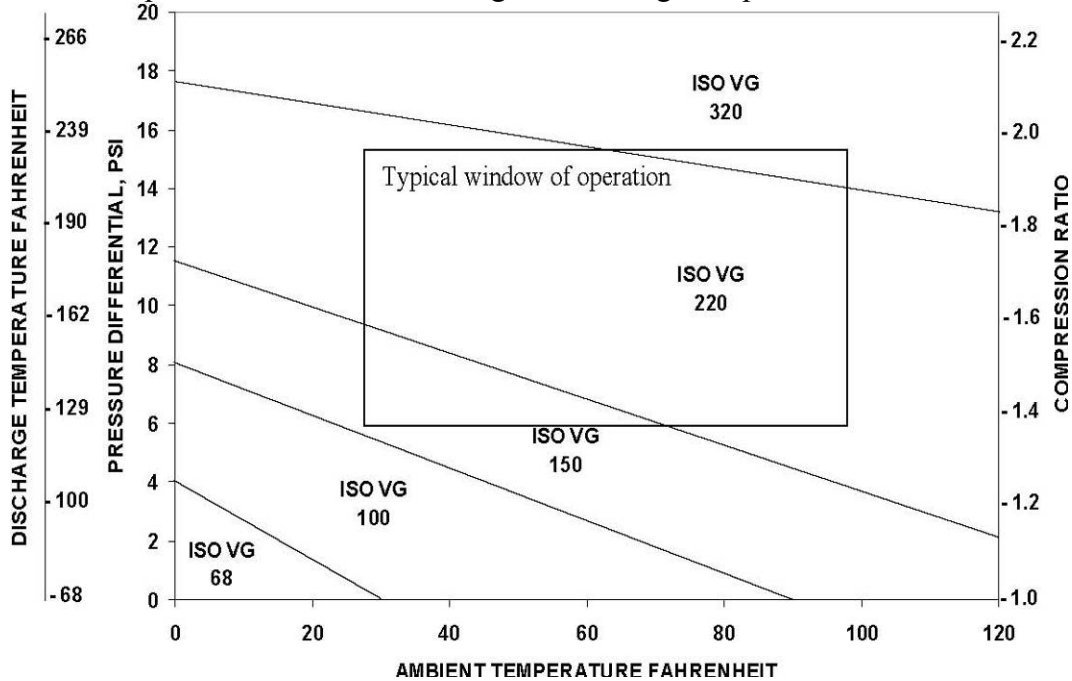

*Synthetic lubricants are highly recommended over mineral lubricants: synthetics last up to 4 times longer; and a single viscosity can cover a broader temperature range.*

Consult factory for oil recommendations on special applications.

Use general purpose lithium grease suitable for temperature ranges of -4° F to 248° F.

## 4.6. Nameplate

The nameplate of the rotary blower is located on the oil cover gear side

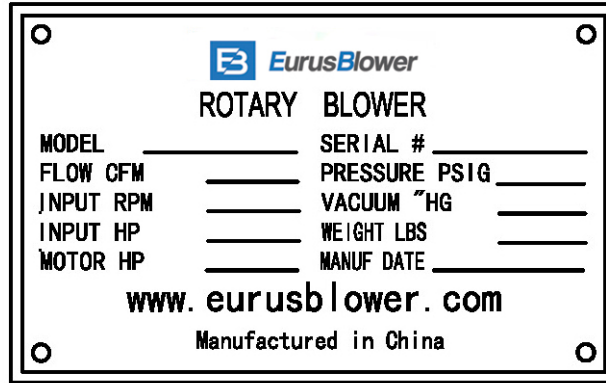

## 4.7. Dimensional Drawings

Documents can be provided by Eurus Blower Customer Service Department

## 4.8. Performance Curves

Performance curves can be provided by Eurus Blower Customer Service Department

## 4.9. Performance Tables

Performance tables can be provided by Eurus Blower Customer Service Department



## 5. Safety Instructions

Read this service manual carefully and abide by all warnings and precautions before putting the rotary blower into operation and/or before performing any maintenance.

### 5.1. Warning Symbols

| Symbol  | Meaning   |
|---|---|
|  | <p><b>This symbol indicates information that can cause injury or death. It is critical that these rules are observed and that extreme care is taken in these cases. For their own protection, inform all other users of these safety rules. Observe general safety and accident prevention rules as well as the safety procedures in this manual.</b></p> |

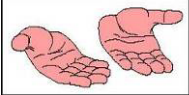

|  |   |
|--|---|
|   | <p>This symbol indicates considerable attention must be paid to recommendations, regulations, references and correct sequencing so that damage and/or destruction of the rotary blower and/or other equipment is prevented.</p> |
| <br> | <p>This symbol indicates environmental protection measures.</p> <p>This symbol indicates manual operations that are to be performed by the operator or service technician.</p>  |

## 5.2 Safety warning and regulations (OSHA CFR 29, 19100)



**Observe the following warnings when operating rotary blowers:**

- Because of danger to maintenance and operation personnel from rotating parts, high temperatures and harmful noise, protective measures against these hazards must be taken by the user.
- No open flame or flying sparks should be in the vicinity of unit.
- If any welding or grinding work is needed near the rotary blower, ensure that sparks or high temperatures cannot cause fire or explosion.
- Operating personnel must be instructed on the necessity of wearing hearing protection during operation of the rotary blower - especially when operating without the acoustic hood.
- Do not stay for long periods in the direct vicinity of operating rotary blowers with damaging noise levels.



- Do not use rotary blowers to convey or handle explosive or damaging gases.
- Because of the high temperatures generated (up to 313°F), do not touch pipes or ancillaries during operation of the rotary blower. Wait until the blower has cooled down and pressure is vented before performing any repairs.
- Only specially trained personnel should work on power driven systems.

## 5.3 General References

**Attention!**

The rotary blower is not capable of functioning as an independent machine: it is designed as a sub-component to be used and controlled within a bigger system.

The rotary blower may only be put into operation as an integral part of a complete system that has been subjected to a safety inspection proving that it conforms to the requirements of relevant safety regulations (see OSHA CFR 29, 1910)

## 6. Arrival and Use of the Rotary Blower

### 6.1 Arrival Inspection



Before accepting the shipment, perform the following inspections:

- Review the packing slip and verify that all components and accessories are included and undamaged. Uncrate or remove, from packing, all items and inspect them thoroughly. Report any damage or missing items described on the packing slip with the carrier.
- Rotate the shaft and insure smooth rotation by hand. If the contamination covers are still on the inlet and outlet of the unit, expect some resistance when turning the shaft..



- Do not remove port covers. A rust inhibitor is applied at the factory to insure rust free air chamber. Wait until installation before removing covers. Once removed, the air chamber will be exposed to dirt and debris and the rust inhibitor will begin to evaporate.

## 6.2 Proper Use of the Rotary Blower

The rotary blower package is intended solely for the transport of oil-free air or any inert gas without any liquids or solids and in conformity with the technical specifications. For special gas applications contact Eurus Blower's Engineering Department.

**Attention!**

Do not use this blower for any combustible or oxidizing gas applications.

Any other use is considered incorrect and will void the warranty and may cause injury or death. The manufacturer cannot accept liability for any damage caused by incorrect use. The user alone is liable for any risks incurred.

Correct use also means compliance with the installation, removal, commissioning, operational and maintenance instructions written in this manual.

**This service manual is intended for operating, maintenance and supervisory personnel use only.**

## 7. Moving and Handling

### 7.1 Handling Instructions

To avoid damage to the rotary blower, it is recommended to use a forklift truck; pallet jack; hoist; crane; chain; cable or a sling with certified capacities according to safety. Abide by all safety and regulatory procedures when handling rotary blowers.

### 7.2 Handling with a Forklift or Pallet Jack

Always place the rotary blower on a suitable pallet, box or platform to prevent tipping. Be sure the platform can support the full weight of the unit. Directly fasten the rotary

**Attention!**

Do not lift rotary blower unit directly with the forks of a forklift or pallet jack: this can cause injury to operator and damage to the unit.



blower to the structure using the mounting feet provided prior to moving the unit.

## 7.3 Handling with a Crane Hook

When lifting the rotary blower with a crane hook and slings, use the two Lifting Lugs provided to distribute the load evenly.



- **When transporting the rotary blower with a crane, all standard safety practices and regulations regarding this type of operation must be observed.**
- **Do not stand below a hanging load.**



- **Do not exceed the maximum permissible lifting weight specified for the lifting device and rigging elements.**
- **Avoid sudden, sharp vertical movements when lifting, lowering and transporting the rotary blower.**
- **Lift no higher than needed.**

## 7.4. Storage

### 7.4.1 Temporary Storage

If the unit will need to be stored for a short period of time, or there is a long period of time between delivery and installation, store the rotary blower in a dry, covered space. Leave the flanged ports blanked off to prevent contamination of the internal surfaces. Keep the unit off of the ground.

### 7.4.2. Storage for longer than one year

Use Temporary Storage 7.4.1 recommendations plus:

- Apply rust inhibiting oil/grease onto the flanged ports, drive shaft, and any other base metal to protect against corrosion.
- Isolate from secondary vibration
- Change oil annually.

Rotate shaft periodically (a few times biweekly is recommended)





---

### **7.4.3. Recommended Oils for Storage**

External:

EXXON RUST BAN 326

MOBIL Mobilarma 777 OR 778

SHELL V-Product 9703

Internal:

MOBIL Mobilarma 523 or 524

SHELL RIMULA 30 or ROTELLA T 20W20

### **7.4.4. Operating after long-term storage**

To operate the unit after long-term storage, perform the following:

- Make sure the rotors rotate smoothly when rotated by hand; the lobe surface and the air chamber inside are clear.
- Perform the standard measures for installing a new unit.  
Change the lubricating oil.

## **8. Operational Characteristics and Construction**

### **8.1 Operational Characteristics**

To develop pressure and move air, two bi-lobe rotors, synchronized by a pair of timing gears, rotate in opposite directions in two cylindrical bores within housing.

A defined quantity of air entering the inlet port is trapped between the rotor and the housing and is carried over to the discharge port against the pressure from the application. The pressure developed depends upon the resistance of the system as well as the inlet and discharge pressures.

Each trapped volume occurs two times every revolution for each rotor, commonly referred to as the volume flow per revolution. Multiplying this by the shaft speed will define the flow rate entering the inlet port. Changing the rotational speed directly affects the volume flow.

Simultaneously, the synchronized rotors and housing serve to prevent back flow by the close proximity of the rotors to one another and the proximity of the rotors to the housing.



Because there is no contact between the rotors and the case, there is no wear and no lubrication is required. (Oil/Grease is required to lubricate the bearings and gear). The lack of contact means that some leakage occurs and the rate is directly related to the pressure differential between ports. As the pressure differential increases, the leakage rate increases.

Furthermore, as the leakage rate increases the adiabatic efficiency decreases, increasing the discharge temperature and power requirement.

The net flow rate and efficiency is then dependent upon the shaft speed, volume flow per revolution, and leakage rate at the operational pressure point.

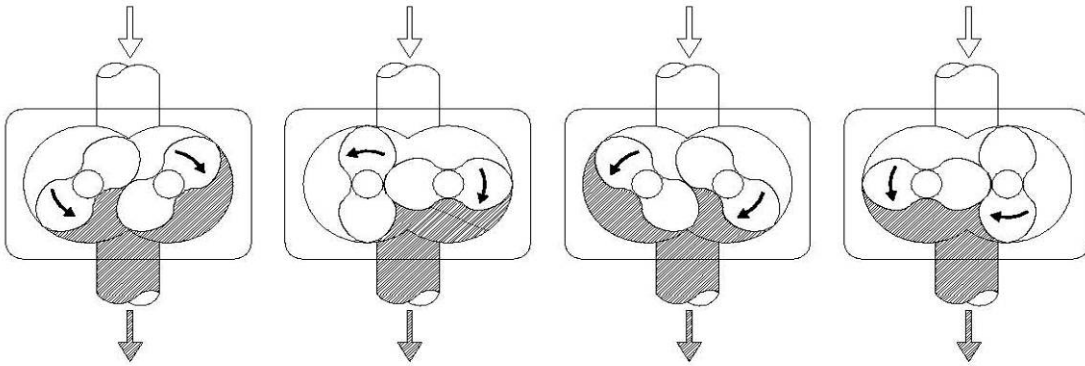

## 8.2 Construction

As described in operating characteristics 8.1, each blower is constructed for a specific volume flow rate per revolution and is defined by design and rotor length. The ZZ Series offers (8) eight models to choose from. Each model offers a variety of flow rates by changing the rotational speed.

To maximize efficiency, materials and clearances are chosen to maintain minimal clearance but reliable operation up to a limiting pressure differential, due to thermal overload. Thermal overload is a point at which the blower cannot dissipate enough heat (thermal energy) to maintain design clearances due to thermal expansion and deformation.

The drive shaft, located on only one rotor, can be driven in both directions and is suitable for direct or belt driven. Directly coupling the motor to the driveshaft allows for maximum power transmission.

The integrated feet allow for a universal installation: in both vertical and horizontal configurations the blower can be mounted from any side, top or bottom.



## 8.3 Horizontal Flow Configuration

- See the following diagram for the positions of the oil level gauge, breather, Plugs, plug magnetic, lifting lug and mounting feet.
- See chapter 4.4 for oil capacities.

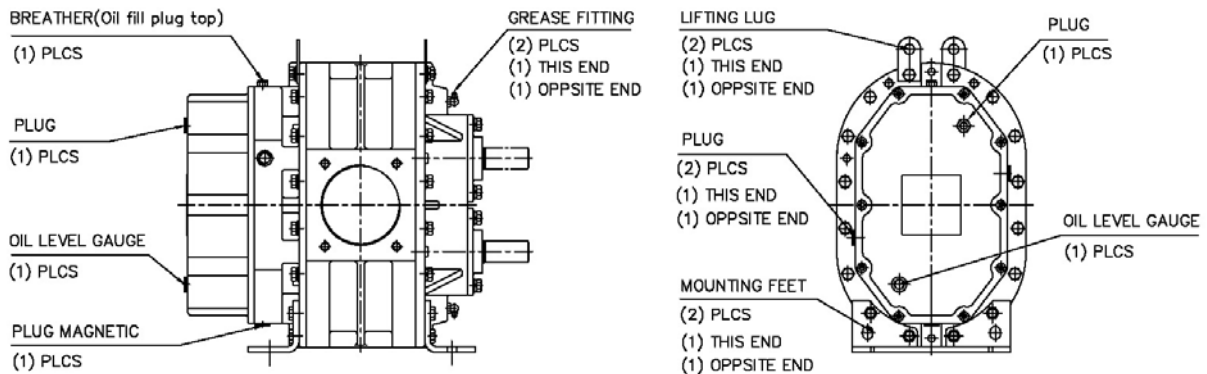

## 8.4 Vertical Flow Configuration

- See the following diagram for the positions of the oil level gauge, breather, Plugs, plug magnetic, lifting lug and mounting feet.
- See chapter 4.4 for oil capacities.

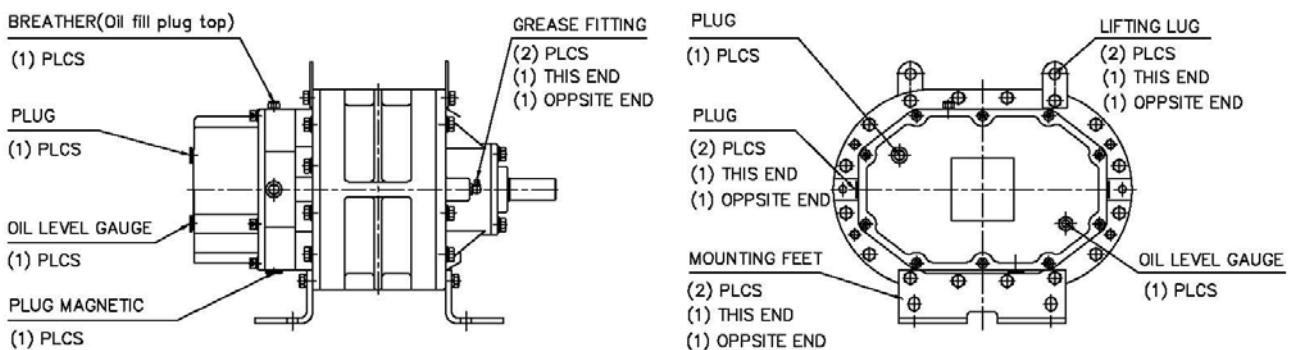



## 8.5 Shaft Diameter and Oil Drain (Oil Fill) Plug Thread

| Dimension \ Model     | ZZ2L  | ZZ3L | ZZ4L    | ZZ5LA | ZZ6L    | ZZ7L  |
|-----------------------|-------|------|---------|-------|---------|-------|
|                       | ZZ2M  | ZZ3M | ZZ4M    | ZZ5MA | ZZ6M    | ZZ7M  |
| Shaft Diameter        | 0.625 | 0.75 | 0.875   | 1.125 | 1.375   | 1.562 |
| Oil Fill Plug Thread  | M12×1 |      | M16×1.5 |       | M20×1.5 |       |
| Oil Drain Plug Thread | M12×1 |      | M16×1.5 |       | M20×1.5 |       |

We can use Adapter Substitute in order to change the oil fill plug and oil drain plug thread into inches.

## 9. Installation and Design Requirements

### 9.1. Installation Requirements

Always operate rotary blowers in a dry and dust free environment.

Most ZZ blowers are shipped from the factory in the vertical flow configuration. According to installation requirements, a ZZ blower can be used in the vertical flow configuration with the drive shaft on either the right or left side; or in the horizontal flow configuration with the drive shaft in the top or bottom position. You must relocating the oil level gauge, breather, Plugs, plug magnetic, lifting lugs and mounting feet to the proper position. When changing the flow configuration, from vertical to horizontal or from horizontal to vertical, **the mounting feet must be removed and rotated 90° so the side that was originally bolted to the blower becomes the base of the foot in the rotated position.** As shown in 8.3 and 8.4.



**Mount the rotary blower on a stable, flat base: uneven mounting can cause stress on the housing**

Leave the flanged ports blanked off until the piping can be installed on the inlet and outlet flanges to prevent foreign particles and/or contamination from entering the blower.

Be sure to support the weight of the pipe work, inlet and discharge silencers, and any other connected components that are attached to the rotary blower. Do not rely on the connections with rotary blower unit to support the weight of these various components.

To isolate vibrations, only flexible pipe connections can be used when connecting the rotary blower to the rest of the system.



Remove the port covers before connecting to the rotary blower.

Check the drive shaft for ease of rotation by hand after installation.

Before installation of the rotary blower check that the oil level gauge, breather, Plugs, plug magnetic, lifting lug and mounting feet are correctly located according to the intended configuration, change them if necessary.

Observe temperature ratings for all system components connected to rotary blower, especially discharge flex union and discharge silencer.

## 9.2 MOUNTING CONFIGURATIONS

The blower flex-mount design enables horizontal and vertical mounting configurations with top or bottom hand, right or left hand shaft positioning. The units are center timed allowing rotation in either direction.

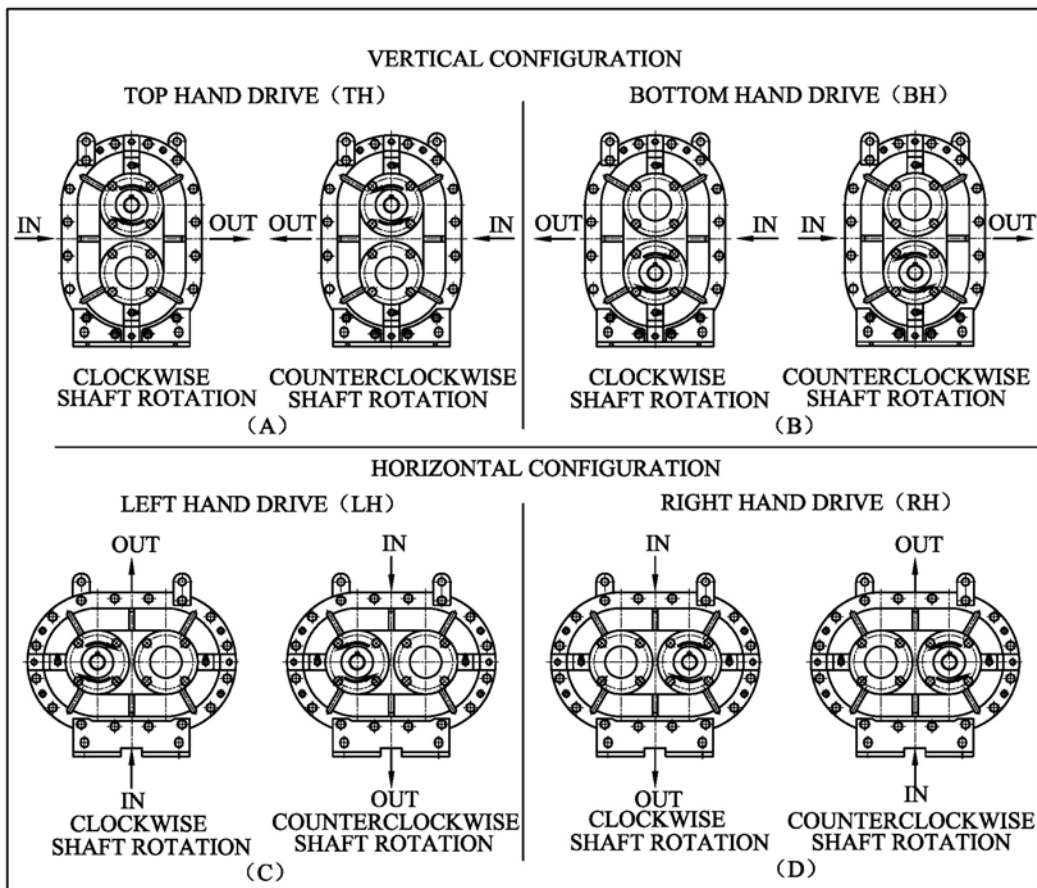



## 9.3. Drive Motor

The rotary blower can be driven by all standard drive sources available on the market.

The rated power of the drive source should be greater than power requirements of blower. Consult industry standard information for their service factor recommendations. Typical minimum service factors are:

- Electric motor: 1.15
- Belt drive systems: 1.5
- Direct drive couplings: 1.4

The speed of the drive source must be selected or controlled such that the maximum permissible rotor speed cannot be exceeded (see chapter 4.1).

Drive system components must:

- Comply with speed ratings advised by their manufacture;
- Be balanced to AGMA class 7 or better;
- Be fitted to the two shafts with line to line up to 0.001” interference (heating of hubs to facilitate assembly is common practice).

**Attention!**

**Protect bearings, pulleys, sheave, coupling hub against impact damage. Do not hammer the components: this may damage the bearings.**

For maximum radial shaft loading

Some axial loading of the drive shaft is permitted, but should be avoided. Static axial loads during assembly can be fully supported without damage. Dynamic (in operation) axial loading will, in some cases, decrease bearing life. If a known dynamic axial load is transmitted by the drive source, consult EURUS BLOWER’S Engineering Department.

All drive system components should have a guard that protects people in the vicinity of the unit from the exposed rotating components. Be sure that the guard is selected and installed with regard to all safety regulations, including OSHA CFR 29, 1910.



---

### 9.3.1. Direct coupled drive with flexible coupling

To directly couple the motor to the input shaft with a flexible coupling:

- The drive and driven shafts must be accurately aligned and have a sufficient gap to minimize axial and radial forces;
- Maximum deviation in offset between drive and driven shaft centerline should not exceed 0.005” TIR(total indicated run-out) referenced from both hubs; and
- Maximum deviation from parallel off centerline or hub faces should not exceed 0.001” when checked at least four points around center.

### 9.3.2. V-belt drive

When using V-belts to connect the motor and rotary blower, consider the following:

- Misalignment of the V-belt drive should not exceed  $\pm 0.5^\circ$  in both parallel and perpendicular planes.
- Use the largest sheave diameters permitted by speed rating to maximize power transfer through the V-belt (This is opposite to economically driven belt drive selection, resulting in small-underrated drives).
- Use belt lengths that keep the center distance between shafts more than 24” and less than 48”.
- Larger center distances are used and favor longer belt life, however the tendency for V-belts to vibrate at resonate frequencies require review.
- Shorter distances mean less misalignment forgiveness, shorter V-belt life, and low speed ratio selection (compact V-belt drives are common, but should be used on low power, low ratio, drive system with higher service factor rating, above 1.5).
- Check the tension of the V-belts and adjust, if necessary, when installing the unit.
- Manual tension adjustment systems need the V-belts checked for tension 30 minutes and 24 hours after every adjustment. Tension should not drift below values recommended by manufacture.



- Automatic tension adjustment systems need adjustment once prior to operation.
- Use of small V-belt cross section for high belt speeds is recommended.
- Avoid selection of V-belts that operate near their speed limit.
- Acceptable Blower Drive Arrangement Options

The driver should be mounted on the inlet side of a vertical unit (horizontal piping) and on the side nearest to the shaft on a horizontal unit.

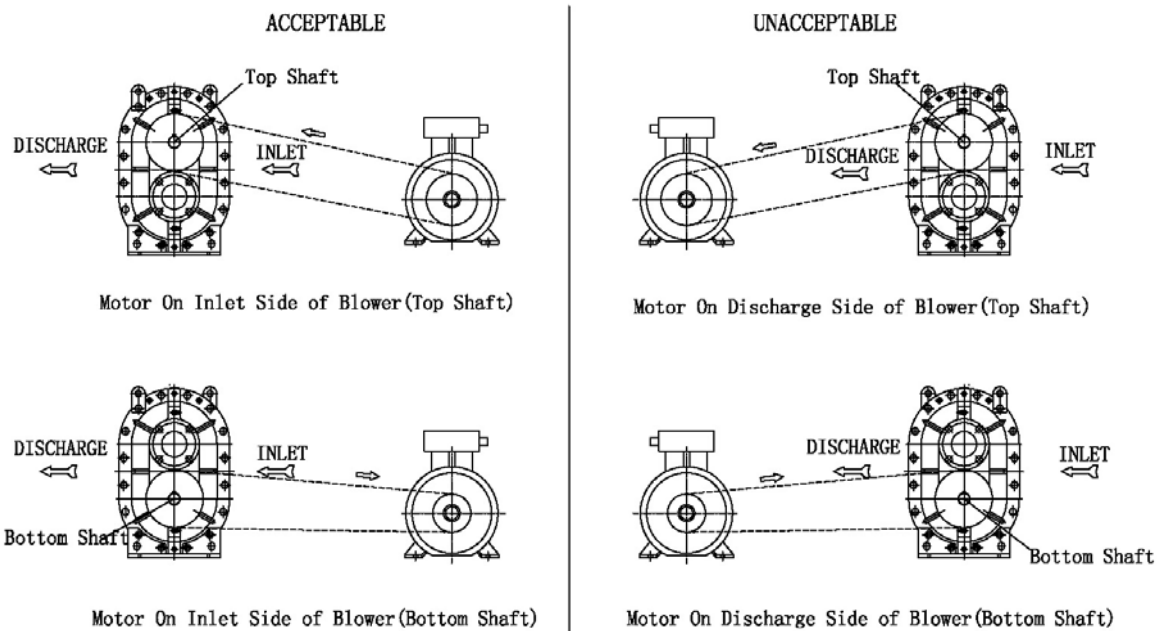

## 9.4. System Safety Equipment

**Attention!**

To ensure safe, automatic operation of the rotary blower the user must install safety control equipment like pressure relief valves.

### 9.4.1. Safety relief valve

A relief valve(s), pressure or vacuum, is necessary to prevent the rotary blower from operating above maximum pressure differential.





A vacuum relief valve should be located before the inlet port if there is any possibility of a blockage in flow to exist which would exceed the maximum pressure differential -especially blowers operating with negative inlet pressure.

A pressure relief valve should be located after the discharge port if any possibility of increased resistance exists to exceed maximum pressure differential - especial blowers operating with positive discharge pressures.

Be sure that pressure relief valves must be rated for temperatures above expected discharge temperatures during operation.

### Set Point

The set point on the relief valve must correspond to the designed operating pressures and the range of condition under which the unit will operate.

**Attention!**

**A pressure relief valve is necessary to be sure that the unit never exceeds its maximum pressure difference by no more than 1 psi – positive pressure or vacuum. This includes full blow- off condition.**

The required relief valve flow rate should be equivalent to the maximum flow delivered by the rotary blower under those inlet and discharge conditions.

The limiting values must be observed.

### 9.4.2 Check valve

A check valve is necessary to prevent a reversal of flow whenever the rotary blower starts and stops.

**Attention!**

**The sizing of the check valve should be rated for the maximum flow rate and maximum operating pressure differential.**

The check valve must:

- Be located after the discharge port for positive pressure and at the inlet port for vacuum; and



- Be rated for temperatures above expected discharge temperatures during operation.

### 9.4.3 Visual Indicators of Temperature and Pressure

Good systems employ local display of the temperature, pressure or vacuum.

**Attention!**

**Location of measurement devices should be at or near the port openings of rotary blower.**

Limits should be displayed on visual indicators for quick assessment of the operating condition.

### 9.4.4 Monitoring Device switches

For safest operation, the operating parameters (temperature and differential pressure) of the unit should be continuously monitored to be sure that they are within the limits set by the manufacturer.

**Attention!**

**The most important parameter to monitor is discharge temperature.**

Because it may take a gauge some time to respond to a change in temperature, sensitive applications should directly monitor the pressure differential.

When a parameter falls out of its limits, corrective action should be quickly initiated to reduce the air resistance or reduce the rotational speed of the rotary blower.

For best results, the measuring devices should trigger the motor controls to immediately shut down the motor.

### 9.4.5. Noise reduction



Attention!

The use of inlet and discharge silencers is highly recommended.

Most designs incorporate some means of noise reduction. Here are a few points on reducing noise:

- Choose chamber type silencers if rotary blower speed is below 2250 rpm.
- Choose absorption/chamber combination silencer when operating rotary blower above 2250 rpm.

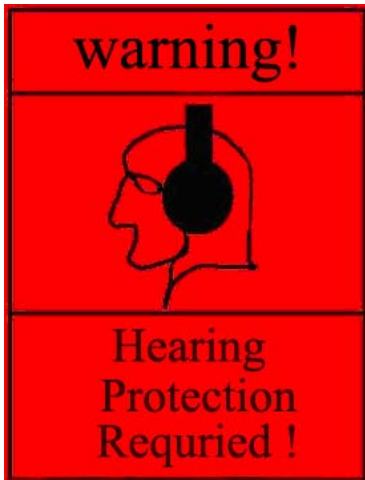

- Use large silencer volumes in excess of 15 times volume flow per revolution to minimize pulsation.
- Use silencers that attenuate peak frequencies equivalent to  $0.06 \times \text{RPM}$ .
- Discharge silencers must be rated for temperatures above expected discharge temperatures during operation.
- Sound enclosures are required to achieve noise levels below 85 dba.
- Sound enclosures must have adequately ventilated to maintain normal ambient operating temperatures.

## 10. Operating a Rotary Blower

### 10.1. Prior to Starting Unit for First Time

Every rotary blower undergoes a mechanical run test at full nameplate pressure prior to leaving the factory. During the test, key indicators, such as vibration and temperature, are monitored for unit quality insuring conformity to specifications.

It is expected that the user employs safe working practices, and that all lawful operating and safety regulations are followed when operating this rotary blower.



## Attention!

**The user carries full responsibility for the installation of the rotary blower and the safety equipment required for safe operation.**

Do not operate this rotary blower in spaces where heavy dust conditions, poisonous or inflammable gasses could exist.

The installation and operating procedures for all ancillary equipment must be observed.

When starting unit for the first time, do the following:

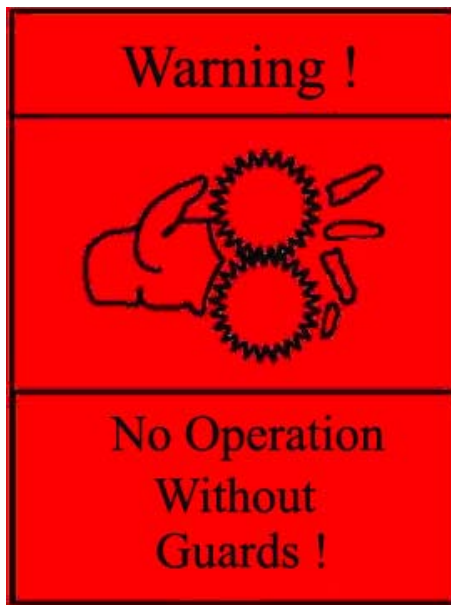

- Carry out a check of all safety and monitoring equipment.
- Check the oil level and top up if necessary.
- Check the direction of rotation of the rotary blower.
- Start with little air resistance and gradually increase.
- Take time to learn the operational characteristics and unit controls before full duty service.



---

## 10.2. Starting and Stopping the Rotary Blower

The rotary blower itself can be stopped and started repeatedly; however, most drive systems should not be subjected to repeated starts and stops. Doing this without increased service factors for all components may decrease the service life of these components.

After stopping the rotary blower, always wait for full stop before restart.

Avoid current inrush to drive source: use starters that allow gradual speed control. Start rotary blower under low load condition.

If possible allow the rotary blower to operate at reduced load, low temperature rise, for 5-10 minute prior to shutdown.

## 10.3. Trouble shooting

If there is a problem with the operation of the unit, consult the following table.

Be sure to note the actions and events that occurred prior to the problem.

Also, record any instrument readings that may be available.

**Attention!**

**All general safety procedures and regulations must be observed while diagnosing and correcting any problems.**



## 10.3.1 Trouble Shooting Guide

| PROBLEM                        | POSSIBLE CAUSES   | SOLUTION   |
|--------------------------------|---|--|
| Knocking                       | 1. Unit out of time.                                    | 1. Re-time impellers   |
|                                | 2. Distortion due to improper mounting or pipe strains. | 2. Check mounting alignment and relieve pipe strains.  |
|                                | 3. Excessive pressure differential.                     | 3. Reduce to manufacturer's recommended pressure. Examine relief valve, re-set if necessary. |
|                                | 4. Worn gears.  | 4. Replace timing gears.   |
|                                | 5. Worn bearings.                                       | 5. Replace bearings.   |
| Excessive blower temperature   | 1. Too much oil in gear case.                           | 1. Reduce oil level.   |
|                                | 2. Too low operating speed.                             | 2. Increase blower speed.  |
|                                | 3. Dirty air Filter.                                    | 3. Clean or replace air filter   |
|                                | 4. Clogged filter or muffler.                           | 4. Remove cause of obstruction.  |
|                                | 5. Excessive pressure differential.                     | 5. Reduce pressure differential across the blower.   |
|                                | 6. Worn impeller clearances.                            | 6. Replace impeller.   |
|                                | 7. Internal contact.                                    | 7. Correct clearances.   |
| Impeller end or tip drag       | 1. Insufficient assembled clearances                    | 1. Correct clearances.   |
|                                | 2. Case or frame distortion.                            | 2. Check mounting and pipe strain.   |
|                                | 3. Excessive operating pressure.                        | 3. Remove cause.   |
|                                | 4. Excessive operating temperature.                     | 4. Remove cause  |
| Lack of volume.                | 1. Slipping belts.                                      | 1. Tighten belts.  |
|                                | 2. Worn clearances.                                     | 2. Re-establish proper clearances.   |
|                                | 3. Dirty air filter                                     | 3. Clean or replace air filter.  |
| Excessive bearing or gear wear | 1. Improper lubrication.                                | 1. Correct lubrication level.<br>Replace dirty oil or greasing.                              |
| Loss of oil                    | 1. End plate, gear case or drive cover vents plugged.   | 1. Clean vents.  |
|                                | 2. Worn Seal.   | 2. Replace seals.  |



## 11. Maintenance

### 11.1 Rules for maintenance

|                   |  |
|-------------------|--|
| <b>Attention!</b> | Always ensure that personnel protective measures are taken according to the accident prevention regulations. |
|-------------------|--|

*Observe the following rules during all maintenance and service work:*

- Only Trained or specialized personnel may perform work on power driven equipment;
- Stop the blower;
- Lock out and tag out the main disconnect switch to prevent a restart

|  |   |
|--|---|
|  | Ensure that all oil and solvents and used parts are disposed of according to federal and local environmental regulations. |
|--|---|

- Isolate and de-pressurize the blower and attached piping to zero psig.

See section 9 for blower operation, starting and stopping.

### 11.2. Regular Maintenance Schedule

| Period                                      | Work to be done   | See Chapter |
|---|---|-------------|
| 1-24 hours after 1 <sup>st</sup> startup    | Check oil level frequently<br>Check belt tension<br>Record baseline data. |             |
| Everyday or frequently                      | check temperature of the bearings, vibration and noise                    |             |
| 100-200 hours after 1 <sup>st</sup> startup | Change lubricating oil  |             |
| Monthly                                     | Check oil level*  |             |
| One year                                    | Check bearing and Oil seal, check Impeller Case and Rotor, check gearing  | ,           |



|                  |                        |  |
|------------------|------------------------|--|
| 1500-2000 hours* | Change oil (mineral)   |  |
| 6000-8000 hours* | Change oil (synthetic) |  |
| 200 hours        | Greasing               |  |

\* The maintenance period can vary depending on the service operating hours per day and environmental conditions. The oil should be changed at least once a year, even if the blower was not operated

Record maintenance work done.

### 11.3 Oil level check

|  |  |   |
|--|--|---|
| <p style="text-align: center;"><b>Warning !</b></p>  <p style="text-align: center;"><b>Hot Surface<br/>Do Not Touch !</b></p> | <p style="text-align: center; font-size: 2em;"><b>Attention!</b></p> | <ul style="list-style-type: none"> <li>• <b>The lubricating oil, rotary blower casing and attached parts can become extremely hot.</b></li> <li>• <b>Check oil chamber of the gear ends.</b></li> </ul> |
|--|--|---|

Stop the rotary blower before checking the oil level. Use the oil level gauge to determine the oil level as instructed below.

**Check oil level on gear end as the rotary blower can be off level. Oil level 1/4" below the center line is in DANGER of failure; low oil level is 1/8" below the center.**

Note: Oil level should be between the center line and 1/8" above center line; if the oil level is more than 1/4" above the center line, there is a risk of oil leakage.

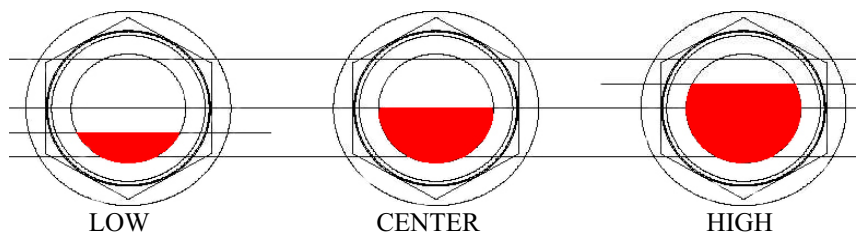

Oil level gauge





---

**To check the lubricating oil level:**

1. Stop the rotary blower.
2. Check the lubrication oil level at all oil level gauge.

**To initially fill the lubricating oil:**

1. Stop the rotary blower and lock-out the power source to prevent a restart;
2. Unscrew the breather on top of the unit;
3. Pour the indicated amount of oil into the port and look at the new oil level in the sight glasses;
4. Fill with lubricating oil to the correct height;
5. Screw the breather in again;
6. Check for leaks.

## 11.4 Lubricating oil/grease Change

Change the lubricating oil when the following occur:

- Carry out the first oil change after approximately 150 hours of service
- Change oil after approximately 1500 –2500 service hours for mineral lubricants approximately 6000-8000 service hours for synthetic lubricants
- Change, at least once annually.
- Change grease every 200 hours.

**To change the lubricating oil:**

- Stop the rotary blower.

**Attention!**

**To avoid the dangers of burning by hot components, wait until the rotary blower has cooled down to below 140 °F.**

- Change oil when the oil is warm, above approximately 130 °F.
- Place a container ready to catch the used oil (see section 1.3 for the oil capacity)
- **The used oil must be collected and disposed of according to all federal and local environmental regulations.**
- Drain the oil by unscrewing the oil drain plug in the bottom of the casing.
- Clean magnet on oil drain plug and screw back into port.
- Fill up with new lubricating oil.
- Screw the breather back into the port.
- Carry out a visual check for leaks.



## 12. Spare parts and after sales

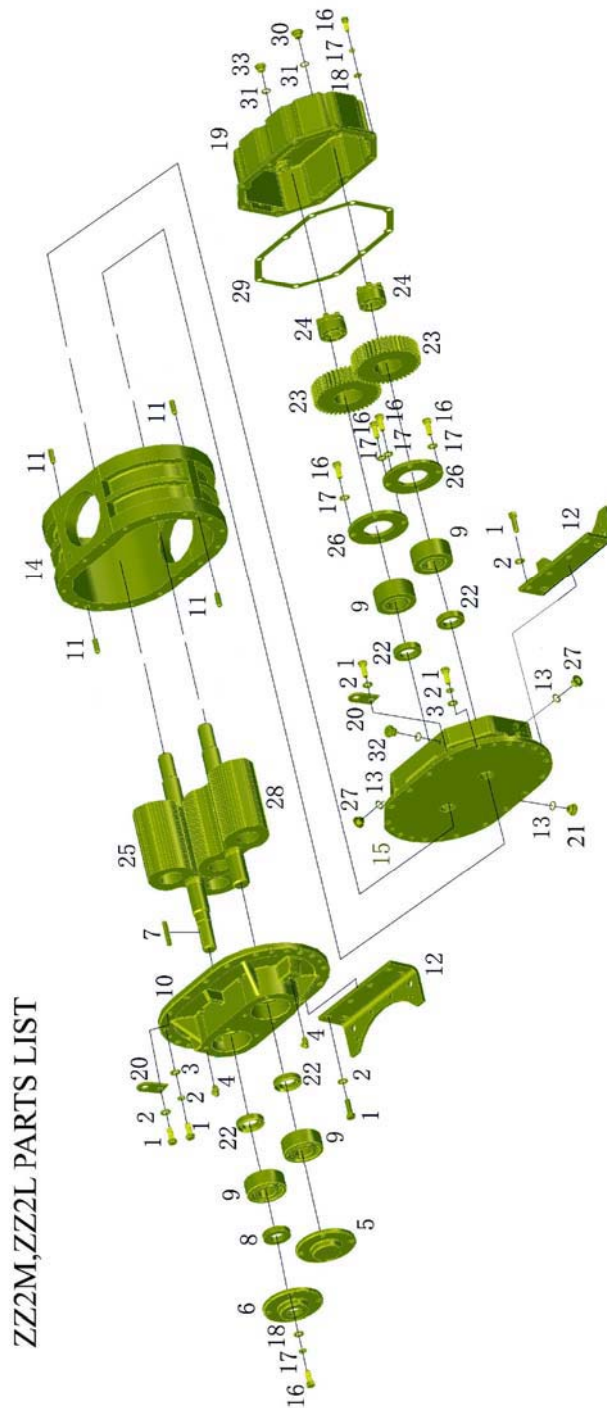



• Model: ZZ2M Parts List

## All Configurations

| ITEM | QTY | PART NUMBER | DESCRIPTION                             | MATERIAL     |
|------|-----|-------------|---|--------------|
| 1    | 24  | ZZ2-001     | Screw M8×25                             | Steel        |
| 2    | 24  | ZZ2-002     | Elastic Washer 8                        | Alloy Steel  |
| 3    | 14  | ZZ2-003     | Washer 8                                | Steel        |
| 4    | 2   | ZZ2-004     | Grease Fitting M10×1                    | Brass        |
| 5    | 1   | ZZ2M-1203   | Drive Side Bearing Cover I              | Aluminum     |
| 6    | 1   | ZZ2M-1204   | Drive Side Bearing Cover II             | Aluminum     |
| 7    | 1   | ZZ3M-1205   | Key-Square                              | Steel        |
| 8    | 1   | ZZ2-005     | Oil Seal TC 16×30×7                     | viton        |
| 9    | 4   | ZZ2-006     | Ball Bearing 6303                       | Steel        |
| 10   | 1   | ZZ2M-0201   | End Plate Drive Side                    | Gray Iron    |
| 11   | 4   | ZZ2-007     | Dowel Pin B8×28                         | Steel        |
| 12   | 2   | ZZ2M-1202   | Mounting Feet –Vertical &<br>Horizontal | Steel        |
| 13   | 4   | ZZ2-008     | O-Ring 10×1.8(ID×CS)                    | viton        |
| 14   | 1   | ZZ2M-0101   | Impeller Case                           | Gray Iron    |
| 15   | 1   | ZZ2M-0202   | End Plate Gear Side                     | Gray Iron    |
| 16   | 26  | ZZ2-009     | Screw M6×20                             | Steel        |
| 17   | 26  | ZZ2-010     | Elastic Washer 6                        | Alloy Steel  |
| 18   | 26  | ZZ2-011     | Washer 6                                | Steel        |
| 19   | 1   | ZZ2M-0311   | Oil Cover Gear Side                     | Aluminum     |
| 20   | 2   | ZZ5M-1206   | Lifting Lug                             | Steel        |
| 21   | 1   | ZZ2-012     | Plug Magnetic M12×1                     | Steel        |
| 22   | 4   | ZZ2-013     | Oil Seal TC 17×35×7                     | viton        |
| 23   | 2   | ZZ2M-1101   | Gear                                    | Alloy Steel  |
| 24   | 2   | ZZ2-014     | Keyless Locking Assembly<br>Z3-16×32    | Steel        |
| 25   | 1   | ZZ2M-0500   | Drive Rotor                             |              |
|      | 1   |             | Impeller                                | Ductile Iron |
|      | 1   |             | Drive Shaft                             | Alloy Steel  |
| 26   | 2   | ZZ2M-0702   | Bearing Clamp Plate                     | Steel        |
| 27   | 2   | ZZ2-015     | Plug M12×1                              | Steel        |
| 28   | 1   | ZZ2M-0600   | Driven Rotor                            |              |
|      | 1   |             | Impeller                                | Ductile Iron |
|      | 1   |             | Driven Shaft                            | Alloy Steel  |
| 29   | 1   | ZZ2M-1207   | Gasket 0.5 mm                           |              |
| 30   | 1   | ZZ2-016     | Plug M16×1.5                            | Steel        |
| 31   | 2   | ZZ2-017     | O-Ring 14×2.65(ID×CS)                   | viton        |
| 32   | 1   | ZZ3M-1209   | Breather M12×1                          | Steel        |
| 33   | 1   | ZZ2-018     | Oil Level Gauge M16×1.5                 | Steel        |



• Model: ZZ2L Parts List

## All Configurations

| ITEM | QTY | PART NUMBER | DESCRIPTION                             | MATERIAL     |
|------|-----|-------------|---|--------------|
| 1    | 24  | ZZ2-001     | Screw M8×25                             | Steel        |
| 2    | 24  | ZZ2-002     | Elastic Washer 8                        | Alloy Steel  |
| 3    | 14  | ZZ2-003     | Washer 8                                | Steel        |
| 4    | 2   | ZZ2-004     | Grease Fitting M10×1                    | Brass        |
| 5    | 1   | ZZ2M-1203   | Drive Side Bearing Cover I              | Aluminum     |
| 6    | 1   | ZZ2M-1204   | Drive Side Bearing Cover II             | Aluminum     |
| 7    | 1   | ZZ3M-1205   | Key-Square                              | Steel        |
| 8    | 1   | ZZ2-005     | Oil Seal TC 16×30×7                     | viton        |
| 9    | 4   | ZZ2-006     | Ball Bearing 6303                       | Steel        |
| 10   | 1   | ZZ2M-0201   | End Plate Drive Side                    | Gray Iron    |
| 11   | 4   | ZZ2-007     | Dowel Pin B8×28                         | Steel        |
| 12   | 2   | ZZ2M-1202   | Mounting Feet –Vertical &<br>Horizontal | Steel        |
| 13   | 4   | ZZ2-008     | O-Ring 10×1.8(ID×CS)                    | viton        |
| 14   | 1   | ZZ2L-0101   | Impeller Case                           | Gray Iron    |
| 15   | 1   | ZZ2M-0202   | End Plate Gear Side                     | Gray Iron    |
| 16   | 26  | ZZ2-009     | Screw M6×20                             | Steel        |
| 17   | 26  | ZZ2-010     | Elastic Washer 6                        | Alloy Steel  |
| 18   | 26  | ZZ2-011     | Washer 6                                | Steel        |
| 19   | 1   | ZZ2M-0311   | Oil Cover Gear Side                     | Aluminum     |
| 20   | 2   | ZZ5M-1206   | Lifting Lug                             | Steel        |
| 21   | 1   | ZZ2-018     | Plug Magnetic M12×1                     | Steel        |
| 22   | 4   | ZZ2-013     | Oil Seal TC 17×35×7                     | viton        |
| 23   | 2   | ZZ2M-1101   | Gear                                    | Alloy Steel  |
| 24   | 2   | ZZ2-014     | Keyless Locking Assembly<br>Z3-16×32    | Steel        |
| 25   | 1   | ZZ2L-0500   | Drive Rotor                             |              |
|      | 1   |             | Impeller                                | Ductile Iron |
|      | 1   |             | Drive Shaft                             | Alloy Steel  |
| 26   | 2   | ZZ2M-0702   | Bearing Clamp Plate                     | Steel        |
| 27   | 2   | ZZ2-015     | Plug M12×1                              | Steel        |
| 28   | 1   | ZZ2L-0600   | Driven Rotor                            |              |
|      | 1   |             | Impeller                                | Ductile Iron |
|      | 1   |             | Driven Shaft                            | Alloy Steel  |
| 29   | 1   | ZZ2M-1207   | Gasket 0.5 mm                           |              |
| 30   | 1   | ZZ2-016     | Plug M16×1.5                            | Steel        |
| 31   | 2   | ZZ2-017     | O-Ring 14×2.65(ID×CS)                   | viton        |
| 32   | 1   | ZZ3M-1209   | Breather M12×1                          | Steel        |
| 33   | 1   | ZZ2-018     | Oil Level Gauge M16×1.5                 | Steel        |



## ZZ3M,ZZ3L PARTS LIST

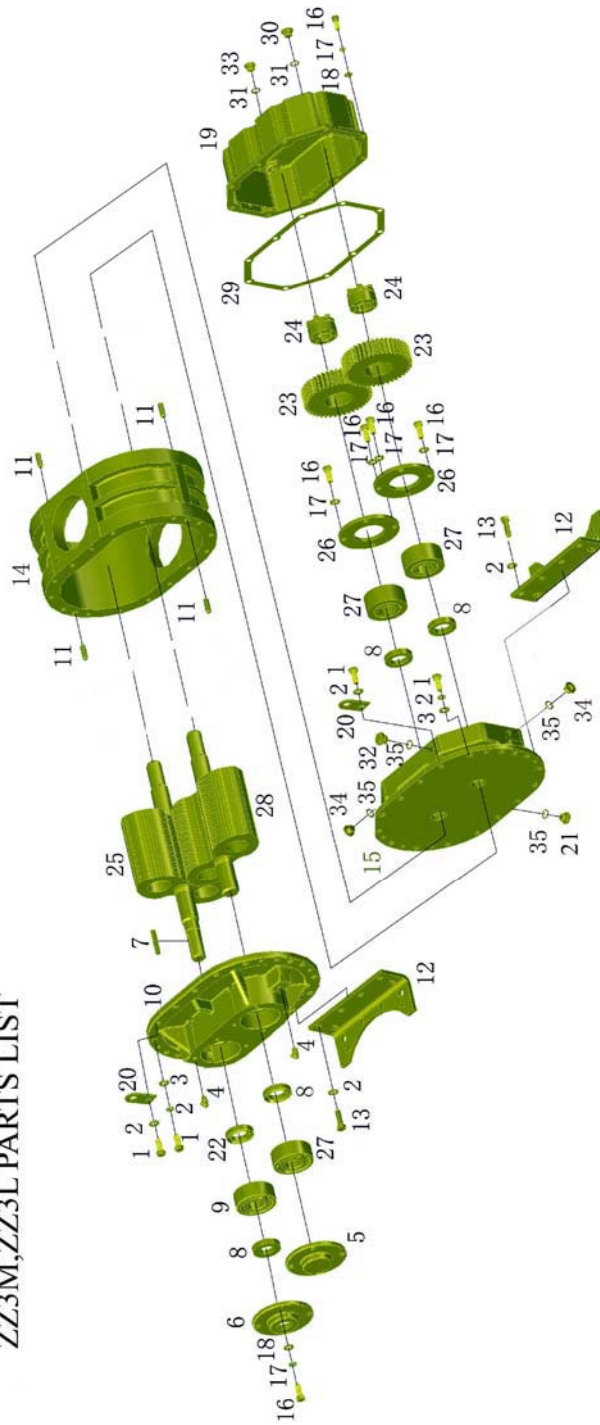



• Model: ZZ3M Parts List

All Configurations

| ITEM | QTY | PART NUMBER | DESCRIPTION                          | MATERIAL     |
|------|-----|-------------|--------------------------------------|--------------|
| 1    | 16  | ZZ3-001     | Screw M10×25                         | Steel        |
| 2    | 24  | ZZ3-002     | Elastic Washer 10                    | Alloy Steel  |
| 3    | 14  | ZZ3-003     | Washer 10                            | Steel        |
| 4    | 2   | ZZ3-004     | Grease Fitting M10×1                 | Brass        |
| 5    | 1   | ZZ3M-1203   | Drive Side Bearing Cover I           | Aluminum     |
| 6    | 1   | ZZ3M-1204   | Drive Side Bearing Cover II          | Aluminum     |
| 7    | 1   | ZZ3M-1205   | Key-Square                           | Steel        |
| 8    | 4   | ZZ3-005     | Oil Seal TC 20×40×7                  | viton        |
| 9    | 1   | ZZ3-006     | Bearing – Roller NJ 2205/C3          | Steel        |
| 10   | 1   | ZZ3M-0201   | End Plate Drive Side                 | Gray Iron    |
| 11   | 4   | ZZ3-007     | Dowel Pin B8×28                      | Steel        |
| 12   | 2   | ZZ3M-1202   | Mounting Feet –Vertical & Horizontal | Steel        |
| 13   | 8   | ZZ3-008     | Screw M10×30                         | Steel        |
| 14   | 1   | ZZ3M-0101   | Impeller Case                        | Gray Iron    |
| 15   | 1   | ZZ3M-0202   | End Plate Gear Side                  | Gray Iron    |
| 16   | 26  | ZZ3-009     | Screw M6×20                          | Steel        |
| 17   | 26  | ZZ3-010     | Elastic Washer 6                     | Alloy Steel  |
| 18   | 26  | ZZ3-011     | Washer 6                             | Steel        |
| 19   | 1   | ZZ3M-0311   | Oil Cover Gear Side                  | Aluminum     |
| 20   | 2   | ZZ5M-1206   | Lifting Lug                          | Steel        |
| 21   | 1   | ZZ3-012     | Plug Magnetic M12×1                  | Steel        |
| 22   | 1   | ZZ3-013     | Oil Seal TC 25×40×7                  | viton        |
| 23   | 2   | ZZ3M-1101   | Gear                                 | Alloy Steel  |
| 24   | 2   | ZZ3-014     | Keyless Locking Assembly Z3-20×47    | Steel        |
| 25   | 1   | ZZ3M-0500   | Drive Rotor Group                    |              |
|      | 1   |             | Impeller                             | Ductile Iron |
|      | 1   |             | Drive Shaft                          | Alloy Steel  |
| 26   | 2   | ZZ3M-0702   | Bearing Clamp Plate                  | Steel        |
| 27   | 3   | ZZ3-015     | Ball Bearing 6304                    | Steel        |
| 28   | 1   | ZZ3M-0600   | Driven Rotor Group                   |              |
|      | 1   |             | Impeller                             | Ductile Iron |
|      | 1   |             | Driven Shaft                         | Alloy Steel  |
| 29   | 1   | ZZ3M-1207   | Gasket 0.5 mm                        |              |
| 30   | 1   | ZZ3-016     | Plug M16×1.5                         | Steel        |
| 31   | 2   | ZZ3-017     | O-Ring 14×2.65(ID×CS)                | viton        |
| 32   | 1   | ZZ3M-1209   | Breather M12×1                       | Steel        |
| 33   | 1   | ZZ3-018     | Oil Level Gauge M16×1.5              | Steel        |
| 34   | 2   | ZZ3-019     | Plug M12×1                           | Steel        |
| 35   | 4   | ZZ3-020     | O-Ring 10×1.8(ID×CS)                 | viton        |



• Model: ZZ3L Parts List

## All Configurations

| ITEM | QTY | PART NUMBER | DESCRIPTION                          | MATERIAL     |
|------|-----|-------------|--------------------------------------|--------------|
| 1    | 16  | ZZ3-001     | Screw M10×25                         | Steel        |
| 2    | 24  | ZZ3-002     | Elastic Washer 10                    | Alloy Steel  |
| 3    | 14  | ZZ3-003     | Washer 10                            | Steel        |
| 4    | 2   | ZZ3-004     | Grease Fitting M10×1                 | Brass        |
| 5    | 1   | ZZ3M-1203   | Drive Side Bearing Cover I           | Aluminum     |
| 6    | 1   | ZZ3M-1204   | Drive Side Bearing Cover II          | Aluminum     |
| 7    | 1   | ZZ3M-1205   | Key-Square                           | Steel        |
| 8    | 4   | ZZ3-005     | Oil Seal TC 20×40×7                  | viton        |
| 9    | 1   | ZZ3-006     | Bearing – Roller NJ 2205/C3          | Steel        |
| 10   | 1   | ZZ3M-0201   | End Plate Drive Side                 | Gray Iron    |
| 11   | 4   | ZZ3-007     | Dowel Pin B8×28                      | Steel        |
| 12   | 2   | ZZ3M-1202   | Mounting Feet –Vertical & Horizontal | Steel        |
| 13   | 8   | ZZ3-008     | Screw M10×30                         | Steel        |
| 14   | 1   | ZZ3L-0101   | Impeller Case                        | Gray Iron    |
| 15   | 1   | ZZ3M-0202   | End Plate Gear Side                  | Gray Iron    |
| 16   | 26  | ZZ3-009     | Screw M6×20                          | Steel        |
| 17   | 26  | ZZ3-010     | Elastic Washer 6                     | Alloy Steel  |
| 18   | 26  | ZZ3-011     | Washer 6                             | Steel        |
| 19   | 1   | ZZ3M-0311   | Oil Cover Gear Side                  | Aluminum     |
| 20   | 2   | ZZ5M-1206   | Lifting Lug                          | Steel        |
| 21   | 1   | ZZ3-012     | Plug Magnetic M12×1                  | Steel        |
| 22   | 1   | ZZ3-013     | Oil Seal TC 25×40×7                  | viton        |
| 23   | 2   | ZZ3M-1101   | Gear                                 | Alloy Steel  |
| 24   | 2   | ZZ3-014     | Keyless Locking Assembly Z3-20×47    | Steel        |
| 25   | 1   | ZZ3L-0500   | Drive Rotor Group                    |              |
|      | 1   |             | Impeller                             | Ductile Iron |
|      | 1   |             | Drive Shaft                          | Alloy Steel  |
| 26   | 2   | ZZ3M-0702   | Bearing Clamp Plate                  | Steel        |
| 27   | 3   | ZZ3-015     | Ball Bearing 6304                    | Steel        |
| 28   | 1   | ZZ3L-0600   | Driven Rotor Group                   |              |
|      | 1   |             | Impeller                             | Ductile Iron |
|      | 1   |             | Driven Shaft                         | Alloy Steel  |
| 29   | 1   | ZZ3M-1207   | Gasket 0.5 mm                        |              |
| 30   | 1   | ZZ3-016     | Plug M16×1.5                         | Steel        |
| 31   | 2   | ZZ3-017     | O-Ring 14×2.65(ID×CS)                | viton        |
| 32   | 1   | ZZ3M-1209   | Breather M12×1                       | Steel        |
| 33   | 1   | ZZ3-018     | Oil Level Gauge M16×1.5              | Steel        |
| 34   | 2   | ZZ3-019     | Plug M12×1                           | Steel        |
| 35   | 4   | ZZ3-020     | O-Ring 10×1.8(ID×CS)                 | viton        |



## ZZ4M,ZZ4L PARTS LIST

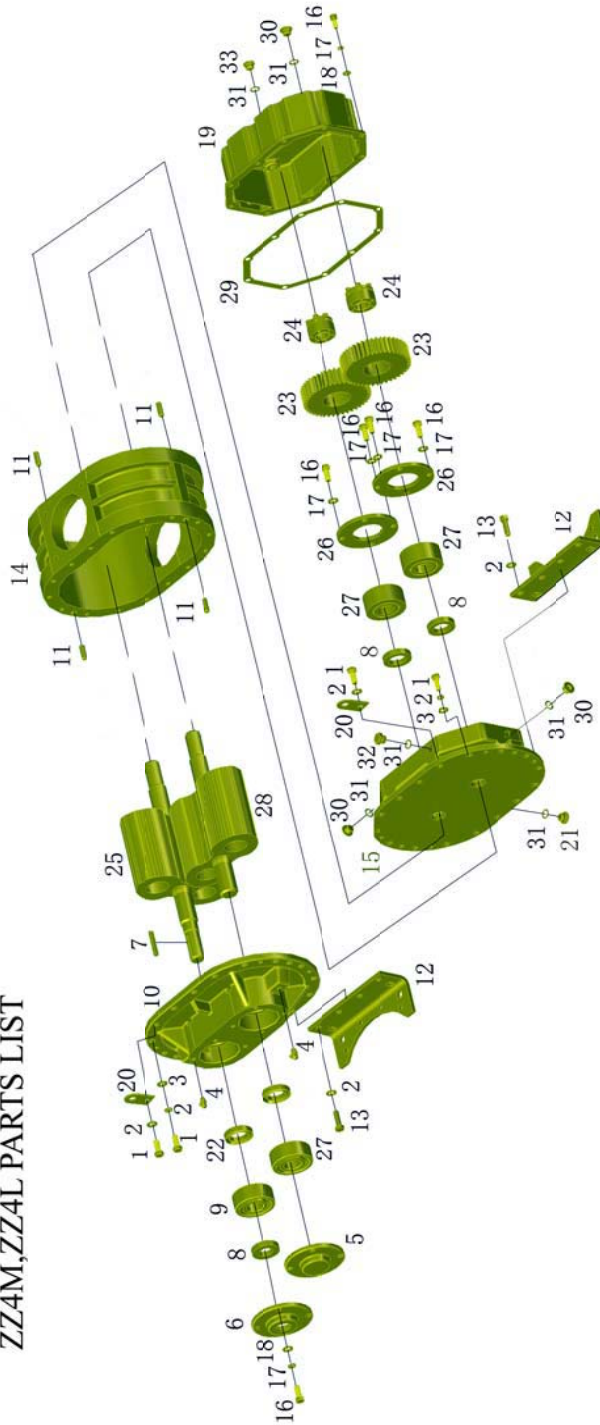





• Model: ZZ4M Parts List

All Configurations

| ITEM | QTY | PART NUMBER | DESCRIPTION                             | MATERIAL     |
|------|-----|-------------|---|--------------|
| 1    | 24  | ZZ4-001     | Screw M10×25                            | Steel        |
| 2    | 32  | ZZ4-002     | Elastic Washer 10                       | Alloy Steel  |
| 3    | 22  | ZZ4-003     | Washer 10                               | Steel        |
| 4    | 2   | ZZ4-004     | Grease Fitting M10×1                    | Brass        |
| 5    | 1   | ZZ4M-1203   | Drive Side Bearing Cover I              | Aluminum     |
| 6    | 1   | ZZ4M-1204   | Drive Side Bearing Cover II             | Aluminum     |
| 7    | 1   | ZZ4M-1205   | Key-Square                              | Steel        |
| 8    | 4   | ZZ4-005     | Oil Seal TC 25×45×7                     | viton        |
| 9    | 1   | ZZ4-006     | Bearing – Roller NJ 2206/C3             | Steel        |
| 10   | 1   | ZZ4M-0201   | End Plate Drive Side                    | Gray Iron    |
| 11   | 4   | ZZ4-007     | Dowel Pin B12×40                        | Steel        |
| 12   | 2   | ZZ4M-1202   | Mounting Feet –Vertical &<br>Horizontal | Steel        |
| 13   | 8   | ZZ4-008     | Screw M10×30                            | Steel        |
| 14   | 1   | ZZ4M-0101   | Impeller Case                           | Gray Iron    |
| 15   | 1   | ZZ4M-0202   | End Plate Gear Side                     | Gray         |
| 16   | 26  | ZZ4-009     | Screw M6×20                             | Steel        |
| 17   | 26  | ZZ4-010     | Elastic Washer 6                        | Alloy Steel  |
| 18   | 26  | ZZ4-011     | Washer 6                                | Steel        |
| 19   | 1   | ZZ4M-0311   | Oil Cover Gear Side                     | Aluminum     |
| 20   | 2   | ZZ5M-1206   | Lifting Lug                             | Steel        |
| 21   | 1   | ZZ4-012     | Plug Magnetic M16×1.5                   | Steel        |
| 22   | 1   | ZZ4-013     | Oil Seal TC 30×45×7                     | viton        |
| 23   | 2   | ZZ4M-1101   | Gear                                    | Alloy Steel  |
| 24   | 2   | ZZ4-014     | Keyless Locking Assembly<br>Z3-25×50    | Steel        |
| 25   | 1   | ZZ4M-0500   | Drive Rotor Group                       |              |
|      | 1   |             | Impeller                                | Ductile Iron |
|      | 1   |             | Drive Shaft                             | Alloy Steel  |
| 26   | 2   | ZZ4M-0702   | Bearing Retainer                        | Steel        |
| 27   | 3   | ZZ4-015     | Ball Bearing 5305                       | Steel        |
| 28   | 1   | ZZ4M-0600   | Driven Rotor Group                      |              |
|      | 1   |             | Impeller                                | Ductile Iron |
|      | 1   |             | Driven Shaft                            | Alloy Steel  |
| 29   | 1   | ZZ4M-1207   | Gasket 0.5 mm                           |              |
| 30   | 3   | ZZ4-016     | Plug M16×1.5                            | Steel        |
| 31   | 6   | ZZ4-017     | O-Ring 14×2.65(ID×CS)                   | viton        |
| 32   | 1   | ZZ5M-1209   | Breather M16×1.5                        | Steel        |
| 33   | 1   | ZZ4-018     | Oil Level Gauge M16×1.5                 | Steel        |



• Model: ZZ4L Parts List

## All Configurations

| ITEM | QTY | PART NUMBER | DESCRIPTION                             | MATERIAL     |
|------|-----|-------------|---|--------------|
| 1    | 24  | ZZ4-001     | Screw M10×25                            | Steel        |
| 2    | 32  | ZZ4-002     | Elastic Washer 10                       | Alloy Steel  |
| 3    | 22  | ZZ4-003     | Washer 10                               | Steel        |
| 4    | 2   | ZZ4-004     | Grease Fitting M10×1                    | Brass        |
| 5    | 1   | ZZ4M-1203   | Drive Side Bearing Cover I              | Aluminum     |
| 6    | 1   | ZZ4M-1204   | Drive Side Bearing Cover II             | Aluminum     |
| 7    | 1   | ZZ4M-1205   | Key-Square                              | Steel        |
| 8    | 4   | ZZ4-005     | Oil Seal TC 25×45×7                     | viton        |
| 9    | 1   | ZZ4-006     | Bearing – Roller NJ 2206/C3             | Steel        |
| 10   | 1   | ZZ4M-0201   | End Plate Drive Side                    | Gray Iron    |
| 11   | 4   | ZZ4-007     | Dowel Pin B12×40                        | Steel        |
| 12   | 2   | ZZ4M-1202   | Mounting Feet –Vertical &<br>Horizontal | Steel        |
| 13   | 8   | ZZ4-008     | Screw M10×30                            | Steel        |
| 14   | 1   | ZZ4L-0101   | Impeller Case                           | Gray Iron    |
| 15   | 1   | ZZ4M-0202   | End Plate Gear Side                     | Gray         |
| 16   | 26  | ZZ4-009     | Screw M6×20                             | Steel        |
| 17   | 26  | ZZ4-010     | Elastic Washer 6                        | Alloy Steel  |
| 18   | 26  | ZZ4-011     | Washer 6                                | Steel        |
| 19   | 1   | ZZ4M-0311   | Oil Cover Gear Side                     | Aluminum     |
| 20   | 2   | ZZ5M-1206   | Lifting Lug                             | Steel        |
| 21   | 1   | ZZ4-012     | Plug Magnetic M16×1.5                   | Steel        |
| 22   | 1   | ZZ4-013     | Oil Seal TC 30×45×7                     | viton        |
| 23   | 2   | ZZ4M-1101   | Gear                                    | Alloy Steel  |
| 24   | 2   | ZZ4-014     | Keyless Locking Assembly<br>Z3-25×50    | Steel        |
| 25   | 1   | ZZ4L-0500   | Drive Rotor Group                       |              |
|      | 1   |             | Impeller                                | Ductile Iron |
|      | 1   |             | Drive Shaft                             | Alloy Steel  |
| 26   | 2   | ZZ4M-0702   | Bearing Retainer                        | Steel        |
| 27   | 3   | ZZ4-015     | Ball Bearing 5305                       | Steel        |
| 28   | 1   | ZZ4L-0600   | Driven Rotor Group                      |              |
|      | 1   |             | Impeller                                | Ductile Iron |
|      | 1   |             | Driven Shaft                            | Alloy Steel  |
| 29   | 1   | ZZ4M-1207   | Gasket 0.5 mm                           |              |
| 30   | 3   | ZZ4-016     | Plug M16×1.5                            | Steel        |
| 31   | 6   | ZZ4-017     | O-Ring 14×2.65(ID×CS)                   | viton        |
| 32   | 1   | ZZ5M-1209   | Breather M16×1.5                        | Steel        |
| 33   | 1   | ZZ4-018     | Oil Level Gauge M16×1.5                 | Steel        |

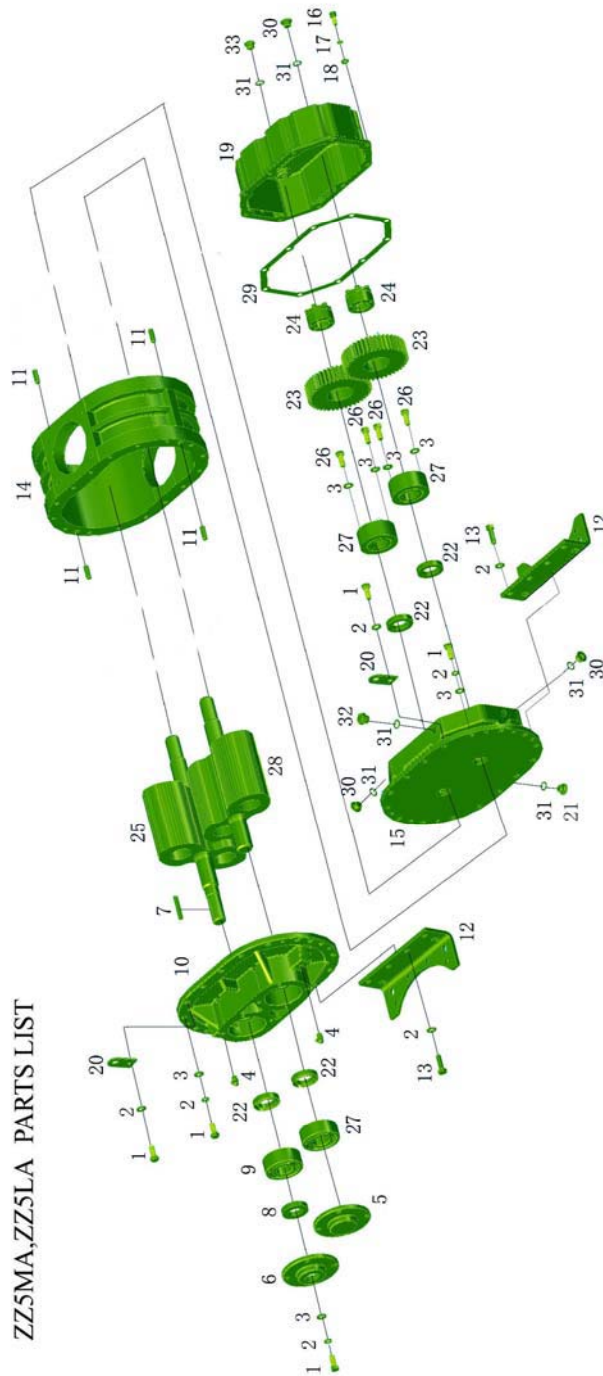



• Model: ZZ5MA Parts List

All Configurations

| ITEM | QTY | PART NUMBER | DESCRIPTION                             | MATERIAL     |
|------|-----|-------------|---|--------------|
| 1    | 32  | ZZ5-001     | Screw M10×30                            | Steel        |
| 2    | 40  | ZZ5-002     | Elastic Washer 10                       | Alloy Steel  |
| 3    | 38  | ZZ5-003     | Washer 10                               | Steel        |
| 4    | 2   | ZZ5-004     | Grease Fitting M10×1                    | Brass        |
| 5    | 1   | ZZ5M-1203   | Drive Side Bearing Cover I              | Aluminum     |
| 6    | 1   | ZZ5M-1204   | Drive Side Bearing Cover II             | Aluminum     |
| 7    | 1   | ZZ5M-1205   | Key-Square                              | Steel        |
| 8    | 1   | ZZ5-005     | Oil Seal TC 30×50×11                    | viton        |
| 9    | 1   | ZZ5-006     | Bearing – Roller NJ 2307/C3             | Steel        |
| 10   | 1   | ZZ5M-0201   | End Plate Drive Side                    | Gray Iron    |
| 11   | 4   | ZZ5-007     | Dowel Pin B12×40                        | Steel        |
| 12   | 2   | ZZ5M-1202A  | Mounting Feet –Vertical &<br>Horizontal | Steel        |
| 13   | 8   | ZZ5-008     | Screw M10×35                            | Steel        |
| 14   | 1   | ZZ5M-0101   | Impeller Case                           | Gray Iron    |
| 15   | 1   | ZZ5M-0202   | End Plate Gear Side                     | Gray Iron    |
| 16   | 10  | ZZ5-009     | Screw M8×25                             | Steel        |
| 17   | 10  | ZZ5-010     | Elastic Washer 8                        | Alloy Steel  |
| 18   | 10  | ZZ5-011     | Washer 8                                | Steel        |
| 19   | 1   | ZZ5M-0311   | Oil Cover Gear Side                     | Aluminum     |
| 20   | 2   | ZZ5M-1206   | Lifting Lug                             | Steel        |
| 21   | 1   | ZZ5-012     | Plug Magnetic M16×1.5                   | Steel        |
| 22   | 4   | ZZ5-013     | Oil Seal TC 35×55×11                    | viton        |
| 23   | 2   | ZZ5M-1101   | Gear                                    | Alloy Steel  |
| 24   | 2   | ZZ5-014     | Keyless Locking Assembly<br>Z3-30×55    | Steel        |
| 25   | 1   | ZZ5M-0500   | Drive Rotor Group                       |              |
|      | 1   |             | Impeller                                | Ductile Iron |
|      | 1   |             | Drive Shaft                             | Alloy Steel  |
| 26   | 4   | ZZ5-015     | Screw M10×20                            | Steel        |
| 27   | 3   | ZZ5-016     | Ball Bearing 5307                       | Steel        |
| 28   | 1   | ZZ5M-0600   | Driven Rotor Group                      |              |
|      | 1   |             | Impeller                                | Ductile Iron |
|      | 1   |             | Driven Shaft                            | Alloy Steel  |
| 29   | 1   | ZZ5M-1207   | Gasket 0.5 mm                           |              |
| 30   | 3   | ZZ5-017     | Plug M16×1.5                            | Steel        |
| 31   | 6   | ZZ5-018     | O-Ring 14×2.65(ID×CS)                   | viton        |
| 32   | 1   | ZZ5M-1209   | Breather M16×1.5                        | Steel        |
| 33   | 1   | ZZ5-019     | Oil Level Gauge M16×1.5                 | Steel        |



• Model: ZZ5LA Parts List

All Configurations

| ITEM | QTY | PART NUMBER | DESCRIPTION                             | MATERIAL     |
|------|-----|-------------|---|--------------|
| 1    | 32  | ZZ5-001     | Screw M10×30                            | Steel        |
| 2    | 40  | ZZ5-002     | Elastic Washer 10                       | Alloy Steel  |
| 3    | 38  | ZZ5-003     | Washer 10                               | Steel        |
| 4    | 2   | ZZ5-004     | Grease Fitting M10×1                    | Brass        |
| 5    | 1   | ZZ5M-1203   | Drive Side Bearing Cover I              | Aluminum     |
| 6    | 1   | ZZ5M-1204   | Drive Side Bearing Cover II             | Aluminum     |
| 7    | 1   | ZZ5M-1205   | Key-Square                              | Steel        |
| 8    | 1   | ZZ5-005     | Oil Seal TC 30×50×11                    | viton        |
| 9    | 1   | ZZ5-006     | Bearing – Roller NJ 2307/C3             | Steel        |
| 10   | 1   | ZZ5M-0201   | End Plate Drive Side                    | Gray Iron    |
| 11   | 4   | ZZ5-007     | Dowel Pin B12×40                        | Steel        |
| 12   | 2   | ZZ5M-1202A  | Mounting Feet –Vertical &<br>Horizontal | Steel        |
| 13   | 8   | ZZ5-008     | Screw M10×35                            | Steel        |
| 14   | 1   | ZZ5L-0101   | Impeller Case                           | Gray Iron    |
| 15   | 1   | ZZ5M-0202   | End Plate Gear Side                     | Gray Iron    |
| 16   | 10  | ZZ5-009     | Screw M8×25                             | Steel        |
| 17   | 10  | ZZ5-010     | Elastic Washer 8                        | Alloy Steel  |
| 18   | 10  | ZZ5-011     | Washer 8                                | Steel        |
| 19   | 1   | ZZ5M-0311   | Oil Cover Gear Side                     | Aluminum     |
| 20   | 2   | ZZ5M-1206   | Lifting Lug                             | Steel        |
| 21   | 1   | ZZ5-012     | Plug Magnetic M16×1.5                   | Steel        |
| 22   | 4   | ZZ5-013     | Oil Seal TC 35×55×11                    | viton        |
| 23   | 2   | ZZ5M-1101   | Gear                                    | Alloy Steel  |
| 24   | 2   | ZZ5-014     | Keyless Locking Assembly<br>Z3-30×55    | Steel        |
| 25   | 1   | ZZ5L-0500   | Drive Rotor Group                       |              |
|      | 1   |             | Impeller                                | Ductile Iron |
|      | 1   |             | Drive Shaft                             | Alloy Steel  |
| 26   | 4   | ZZ5-015     | Screw M10×20                            | Steel        |
| 27   | 3   | ZZ5-016     | Ball Bearing 5307                       | Steel        |
| 28   | 1   | ZZ5L-0600   | Driven Rotor Group                      |              |
|      | 1   |             | Impeller                                | Ductile Iron |
|      | 1   |             | Driven Shaft                            | Alloy Steel  |
| 29   | 1   | ZZ5M-1207   | Gasket 0.5 mm                           |              |
| 30   | 3   | ZZ5-017     | Plug M16×1.5                            | Steel        |
| 31   | 6   | ZZ5-018     | O-Ring 14×2.65(ID×CS)                   | viton        |
| 32   | 1   | ZZ5M-1209   | Breather M16×1.5                        | Steel        |
| 33   | 1   | ZZ5-019     | Oil Level Gauge M16×1.5                 | Steel        |



## ZZ6M,ZZ6L PARTS LIST

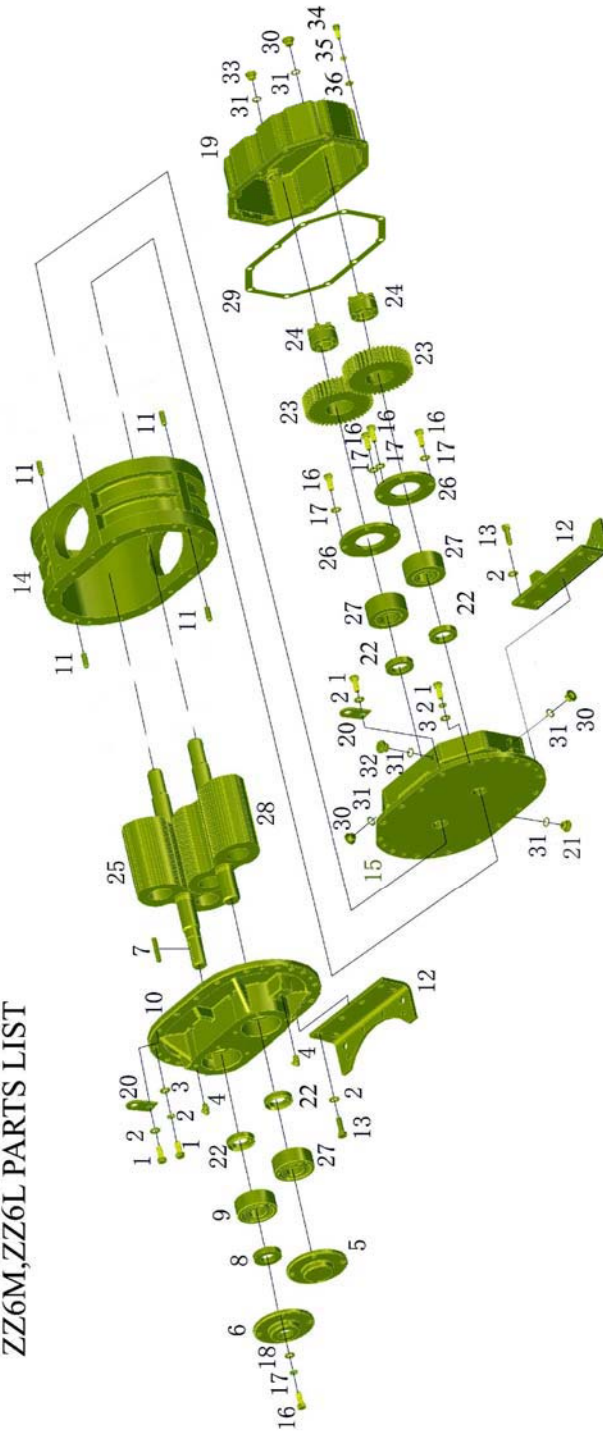



• Model: ZZ6M Parts List

## All Configurations

| ITEM | QTY | PART NUMBER | DESCRIPTION                             | MATERIAL     |
|------|-----|-------------|---|--------------|
| 1    | 24  | ZZ6-001     | Screw M12×35                            | Steel        |
| 2    | 32  | ZZ6-002     | Elastic Washer 12                       | Alloy Steel  |
| 3    | 22  | ZZ6-003     | Washer 12                               | Steel        |
| 4    | 2   | ZZ6-004     | Grease Fitting M10×1                    | Brass        |
| 5    | 1   | ZZ6M-1203   | Drive Side Bearing Cover I              | Aluminum     |
| 6    | 1   | ZZ6M-1204   | Drive Side Bearing Cover II             | Aluminum     |
| 7    | 1   | ZZ6M-1205   | Key-Square                              | Steel        |
| 8    | 1   | ZZ6-005     | Oil Seal TB 38×58×11                    | viton        |
| 9    | 1   | ZZ6-006     | Bearing – Roller NJ 2308/C3             | Steel        |
| 10   | 1   | ZZ6M-0201   | End Plate Drive Side                    | Gray Iron    |
| 11   | 4   | ZZ6-007     | Dowel Pin B12×40                        | Steel        |
| 12   | 2   | ZZ6M-1202   | Mounting Feet –Vertical &<br>Horizontal | Steel        |
| 13   | 8   | ZZ6-008     | Screw M12×45                            | Steel        |
| 14   | 1   | ZZ6M-0101   | Impeller Case                           | Gray Iron    |
| 15   | 1   | ZZ6M-0202   | End Plate Gear Side                     | Gray         |
| 16   | 16  | ZZ6-009     | Screw M10×25                            | Steel        |
| 17   | 16  | ZZ6-010     | Elastic Washer 10                       | Alloy Steel  |
| 18   | 8   | ZZ6-011     | Washer 10                               | Steel        |
| 19   | 1   | ZZ6M-0311   | Oil Cover Gear Side                     | Aluminum     |
| 20   | 2   | ZZ6M-1206   | Lifting Lug                             | Steel        |
| 21   | 1   | ZZ6-012     | Plug Magnetic M20×1.5                   | Steel        |
| 22   | 4   | ZZ6-013     | Oil Seal TB 40×62×12                    | viton        |
| 23   | 2   | ZZ6M-1101   | Gear                                    | Alloy Steel  |
| 24   | 2   | ZZ6-014     | Keyless Locking Assembly<br>Z3-40×65    | Steel        |
| 25   | 1   | ZZ6M-0500   | Drive Rotor Group                       |              |
|      | 1   |             | Impeller                                | Ductile Iron |
|      | 1   |             | Drive Shaft                             | Alloy Steel  |
| 26   | 2   | ZZ6M-0702   | Bearing Retainer                        | Steel        |
| 27   | 3   | ZZ6-015     | Ball Bearing 5308                       | Steel        |
| 28   | 1   | ZZ6M-0600   | Driven Rotor Group                      |              |
|      | 1   |             | Impeller                                | Ductile Iron |
|      | 1   |             | Driven Shaft                            | Alloy Steel  |
| 29   | 1   | ZZ6M-1207   | Gasket 0.5 mm                           |              |
| 30   | 3   | ZZ6-016     | Plug M20×1.5                            | Steel        |
| 31   | 6   | ZZ6-017     | O-Ring 18×2.65(ID×CS)                   | viton        |
| 32   | 1   | ZZ7M-1209   | Breather M20×1.5                        | Steel        |
| 33   | 1   | ZZ6-018     | Oil Level Gauge M20×1.5                 | Steel        |
| 34   | 10  | ZZ6-019     | Screw M8×25                             | Steel        |
| 35   | 10  | ZZ6-020     | Elastic Washer 8                        | Alloy Steel  |
| 36   | 10  | ZZ6-021     | Washer 8                                | Steel        |



• Model: ZZ6L Parts List

All Configurations

| ITEM | QTY | PART NUMBER | DESCRIPTION                             | MATERIAL     |
|------|-----|-------------|---|--------------|
| 1    | 24  | ZZ6-001     | Screw M12×35                            | Steel        |
| 2    | 32  | ZZ6-002     | Elastic Washer 12                       | Alloy Steel  |
| 3    | 22  | ZZ6-003     | Washer 12                               | Steel        |
| 4    | 2   | ZZ6-004     | Grease Fitting M10×1                    | Brass        |
| 5    | 1   | ZZ6M-1203   | Drive Side Bearing Cover I              | Aluminum     |
| 6    | 1   | ZZ6M-1204   | Drive Side Bearing Cover II             | Aluminum     |
| 7    | 1   | ZZ6M-1205   | Key-Square                              | Steel        |
| 8    | 1   | ZZ6-005     | Oil Seal TB 38×58×11                    | viton        |
| 9    | 1   | ZZ6-006     | Bearing – Roller NJ 2308/C3             | Steel        |
| 10   | 1   | ZZ6M-0201   | End Plate Drive Side                    | Gray Iron    |
| 11   | 4   | ZZ6-007     | Dowel Pin B12×40                        | Steel        |
| 12   | 2   | ZZ6M-1202   | Mounting Feet –Vertical &<br>Horizontal | Steel        |
| 13   | 8   | ZZ6-008     | Screw M12×45                            | Steel        |
| 14   | 1   | ZZ6M-0101   | Impeller Case                           | Gray Iron    |
| 15   | 1   | ZZ6M-0202   | End Plate Gear Side                     | Gray         |
| 16   | 16  | ZZ6-009     | Screw M10×25                            | Steel        |
| 17   | 16  | ZZ6-010     | Elastic Washer 10                       | Alloy Steel  |
| 18   | 8   | ZZ6-011     | Washer 10                               | Steel        |
| 19   | 1   | ZZ6M-0311   | Oil Cover Gear Side                     | Aluminum     |
| 20   | 2   | ZZ6M-1206   | Lifting Lug                             | Steel        |
| 21   | 1   | ZZ6-012     | Plug Magnetic M20×1.5                   | Steel        |
| 22   | 4   | ZZ6-013     | Oil Seal TB 40×62×12                    | viton        |
| 23   | 2   | ZZ6M-1101   | Gear                                    | Alloy Steel  |
| 24   | 2   | ZZ6-014     | Keyless Locking Assembly<br>Z3-40×65    | Steel        |
| 25   | 1   | ZZ6L-0500   | Drive Rotor Group                       |              |
|      | 1   |             | Impeller                                | Ductile Iron |
|      | 1   |             | Drive Shaft                             | Alloy Steel  |
| 26   | 2   | ZZ6M-0702   | Bearing Retainer                        | Steel        |
| 27   | 3   | ZZ6-015     | Ball Bearing 5308                       | Steel        |
| 28   | 1   | ZZ6L-0600   | Driven Rotor Group                      |              |
|      | 1   |             | Impeller                                | Ductile Iron |
|      | 1   |             | Driven Shaft                            | Alloy Steel  |
| 29   | 1   | ZZ6M-1207   | Gasket 0.5 mm                           |              |
| 30   | 3   | ZZ6-016     | Plug M20×1.5                            | Steel        |
| 31   | 6   | ZZ6-017     | O-Ring 18×2.65(ID×CS)                   | viton        |
| 32   | 1   | ZZ7M-1209   | Breather M20×1.5                        | Steel        |
| 33   | 1   | ZZ6-018     | Oil Level Gauge M20×1.5                 | Steel        |
| 34   | 10  | ZZ6-019     | Screw M8×25                             | Steel        |
| 35   | 10  | ZZ6-020     | Elastic Washer 8                        | Alloy Steel  |
| 36   | 10  | ZZ6-021     | Washer 8                                | Steel        |





## ZZ7M,ZZ7L PARTS LIST

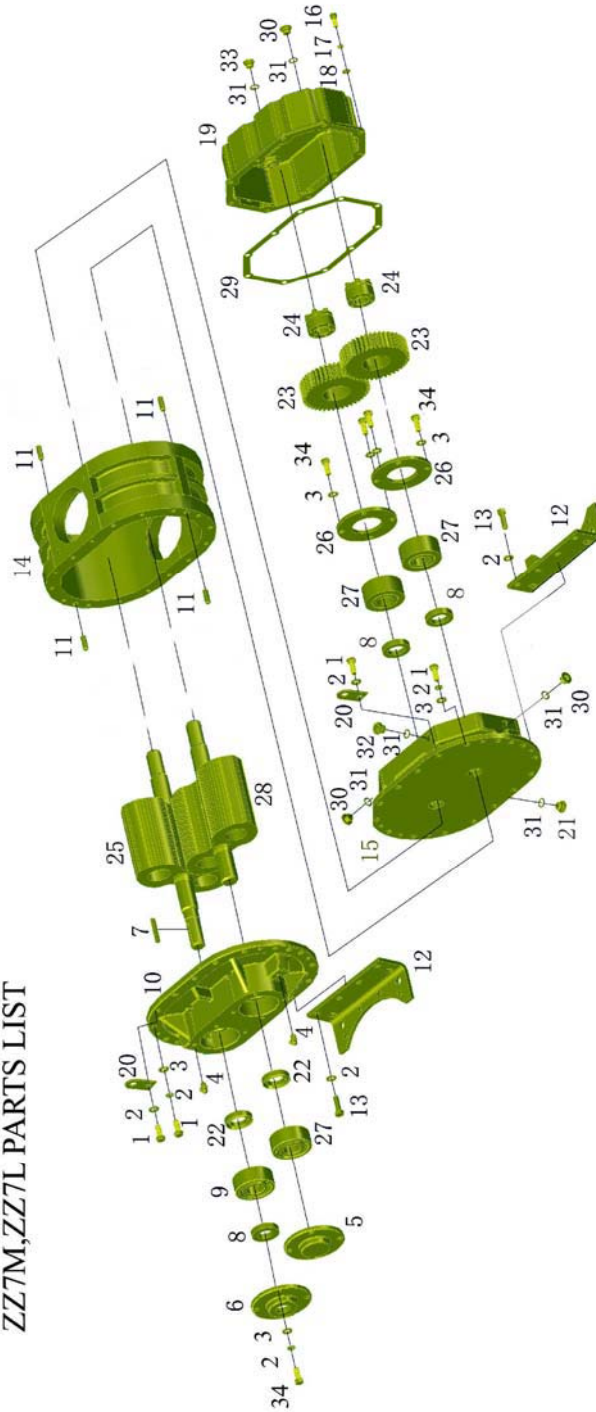



## ZZ7M Parts List

### All Configurations

| ITEM | QTY | PART NUMBER | DESCRIPTION                             | MATERIAL     |
|------|-----|-------------|---|--------------|
| 1    | 24  | ZZ7-001     | Screw M12×35                            | Steel        |
| 2    | 48  | ZZ7-002     | Elastic Washer 12                       | Alloy Steel  |
| 3    | 30  | ZZ7-003     | Washer 12                               | Steel        |
| 4    | 2   | ZZ7-004     | Grease Fitting M10×1                    | Brass        |
| 5    | 1   | ZZ7M-1203   | Drive Side Bearing Cover I              | Aluminum     |
| 6    | 1   | ZZ7M-1204   | Drive Side Bearing Cover II             | Aluminum     |
| 7    | 1   | ZZ7M-1205   | Key-Square                              | Steel        |
| 8    | 4   | ZZ7-005     | Oil Seal TB 42×65×10                    | viton        |
| 9    | 1   | ZZ7-006     | Bearing – Roller NJ 2309/C3             | Steel        |
| 10   | 1   | ZZ7M-0201   | End Plate Drive Side                    | Gray Iron    |
| 11   | 4   | ZZ7-007     | Dowel Pin B12×40                        | Steel        |
| 12   | 2   | ZZ7M-1202   | Mounting Feet –Vertical &<br>Horizontal | Steel        |
| 13   | 8   | ZZ7-008     | Screw M12×45                            | Steel        |
| 14   | 1   | ZZ7M-0101   | Impeller Case                           | Gray Iron    |
| 15   | 1   | ZZ7M-0202   | End Plate Gear Side                     | Gray         |
| 16   | 26  | ZZ7-009     | Screw M10×30                            | Steel        |
| 17   | 26  | ZZ7-010     | Elastic Washer 10                       | Alloy Steel  |
| 18   | 26  | ZZ7-011     | Washer 10                               | Steel        |
| 19   | 1   | ZZ7M-0311   | Oil Cover Gear Side                     | Aluminum     |
| 20   | 2   | ZZ6M-1206   | Lifting Lug                             | Steel        |
| 21   | 1   | ZZ7-012     | Plug Magnetic M20×1.5                   | Steel        |
| 22   | 1   | ZZ7-013     | Oil Seal TB 45×75×8                     | viton        |
| 23   | 2   | ZZ7M-1101   | Gear                                    | Alloy Steel  |
| 24   | 2   | ZZ7-014     | Keyless Locking Assembly<br>Z3-45×75    | Steel        |
| 25   | 1   | ZZ7M-0500   | Drive Rotor Group                       |              |
|      | 1   |             | Impeller                                | Ductile Iron |
|      | 1   |             | Drive Shaft                             | Alloy Steel  |
| 26   | 2   | ZZ7M-0702   | Bearing Retainer                        | Steel        |
| 27   | 3   | ZZ7-015     | Ball Bearing 5309                       | Steel        |
| 28   | 1   | ZZ7M-0600   | Driven Rotor Group                      |              |
|      | 1   |             | Impeller                                | Ductile Iron |
|      | 1   |             | Driven Shaft                            | Alloy Steel  |
| 29   | 1   | ZZ7M-1207   | Gasket 0.5 mm                           |              |
| 30   | 3   | ZZ7-016     | Plug M20×1.5                            | Steel        |
| 31   | 6   | ZZ7-017     | O-Ring 18×2.65(ID×CS)                   | viton        |
| 32   | 1   | ZZ5M-1209   | Breather M20×1.5                        | Steel        |
| 33   | 1   | ZZ7-018     | Oil Level Gauge M20×1.5                 | Steel        |
| 34   | 16  | ZZ7-018     | Screw M12×30                            | Steel        |



• Model: ZZ7L Parts List

## All Configurations

| ITEM | QTY | PART NUMBER | DESCRIPTION                             | MATERIAL     |
|------|-----|-------------|---|--------------|
| 1    | 24  | ZZ7-001     | Screw M12×35                            | Steel        |
| 2    | 48  | ZZ7-002     | Elastic Washer 12                       | Alloy Steel  |
| 3    | 30  | ZZ7-003     | Washer 12                               | Steel        |
| 4    | 2   | ZZ7-004     | Grease Fitting M10×1                    | Brass        |
| 5    | 1   | ZZ7M-1203   | Drive Side Bearing Cover I              | Aluminum     |
| 6    | 1   | ZZ7M-1204   | Drive Side Bearing Cover II             | Aluminum     |
| 7    | 1   | ZZ7M-1205   | Key-Square                              | Steel        |
| 8    | 4   | ZZ7-005     | Oil Seal TB 42×65×10                    | viton        |
| 9    | 1   | ZZ7-006     | Bearing – Roller NJ 2309/C3             | Steel        |
| 10   | 1   | ZZ7M-0201   | End Plate Drive Side                    | Gray Iron    |
| 11   | 4   | ZZ7-007     | Dowel Pin B12×40                        | Steel        |
| 12   | 2   | ZZ7M-1202   | Mounting Feet –Vertical &<br>Horizontal | Steel        |
| 13   | 8   | ZZ7-008     | Screw M12×45                            | Steel        |
| 14   | 1   | ZZ7M-0101   | Impeller Case                           | Gray Iron    |
| 15   | 1   | ZZ7M-0202   | End Plate Gear Side                     | Gray         |
| 16   | 26  | ZZ7-009     | Screw M10×30                            | Steel        |
| 17   | 26  | ZZ7-010     | Elastic Washer 10                       | Alloy Steel  |
| 18   | 26  | ZZ7-011     | Washer 10                               | Steel        |
| 19   | 1   | ZZ7M-0311   | Oil Cover Gear Side                     | Aluminum     |
| 20   | 2   | ZZ6M-1206   | Lifting Lug                             | Steel        |
| 21   | 1   | ZZ7-012     | Plug Magnetic M20×1.5                   | Steel        |
| 22   | 1   | ZZ7-013     | Oil Seal TB 45×75×8                     | viton        |
| 23   | 2   | ZZ7M-1101   | Gear                                    | Alloy Steel  |
| 24   | 2   | ZZ7-014     | Keyless Locking Assembly<br>Z3-45×75    | Steel        |
| 25   | 1   | ZZ7L-0500   | Drive Rotor Group                       |              |
|      | 1   |             | Impeller                                | Ductile Iron |
|      | 1   |             | Drive Shaft                             | Alloy Steel  |
| 26   | 2   | ZZ7M-0702   | Bearing Retainer                        | Steel        |
| 27   | 3   | ZZ7-015     | Ball Bearing 5309                       | Steel        |
| 28   | 1   | ZZ7L-0600   | Driven Rotor Group                      |              |
|      | 1   |             | Impeller                                | Ductile Iron |
|      | 1   |             | Driven Shaft                            | Alloy Steel  |
| 29   | 1   | ZZ7M-1207   | Gasket 0.5 mm                           |              |
| 30   | 3   | ZZ7-016     | Plug M20×1.5                            | Steel        |
| 31   | 6   | ZZ7-017     | O-Ring 18×2.65(ID×CS)                   | viton        |
| 32   | 1   | ZZ5M-1209   | Breather M20×1.5                        | Steel        |
| 33   | 1   | ZZ7-018     | Oil Level Gauge M20×1.5                 | Steel        |
| 34   | 16  | ZZ7-018     | Screw M12×30                            | Steel        |

