

CONVEYOR DESIGN

- 1) Some general points to address in the construction of Flexx Flow Conveyors are the following:
 - a) A belt take up device should be included on any conveyor using Flexx Flow Belting. There are various methods of allowing for this take up, from a simple slotted hole at the tail pulley to a spring or counter weight tension system. This will make belt installation easier and allow for belt stretch which can occur from increased loading or temperature change.
 - b) It is recommended that whenever possible, the drive sprockets be positioned at the conveyor discharge or shortly thereafter.
 - c) Allow adequate clearance across the conveyor width so the belt does not rub against the conveyor side wall. We recommend a minimum $\frac{1}{2}$ " clearance on both sides of the belt.
 - d) Sprocket shaft size must be sufficient in diameter to prevent shaft deflection which can cause the belt to jump teeth or stretch unevenly.
 - e) Drive and tail shafts must be level and parallel to each other.
 - f) Be sure all drive sprockets are keyed alike to maintain even pull on the belt.
- 2) The following illustrations show typical conveyor designs, drive locations, and direction of product flow.

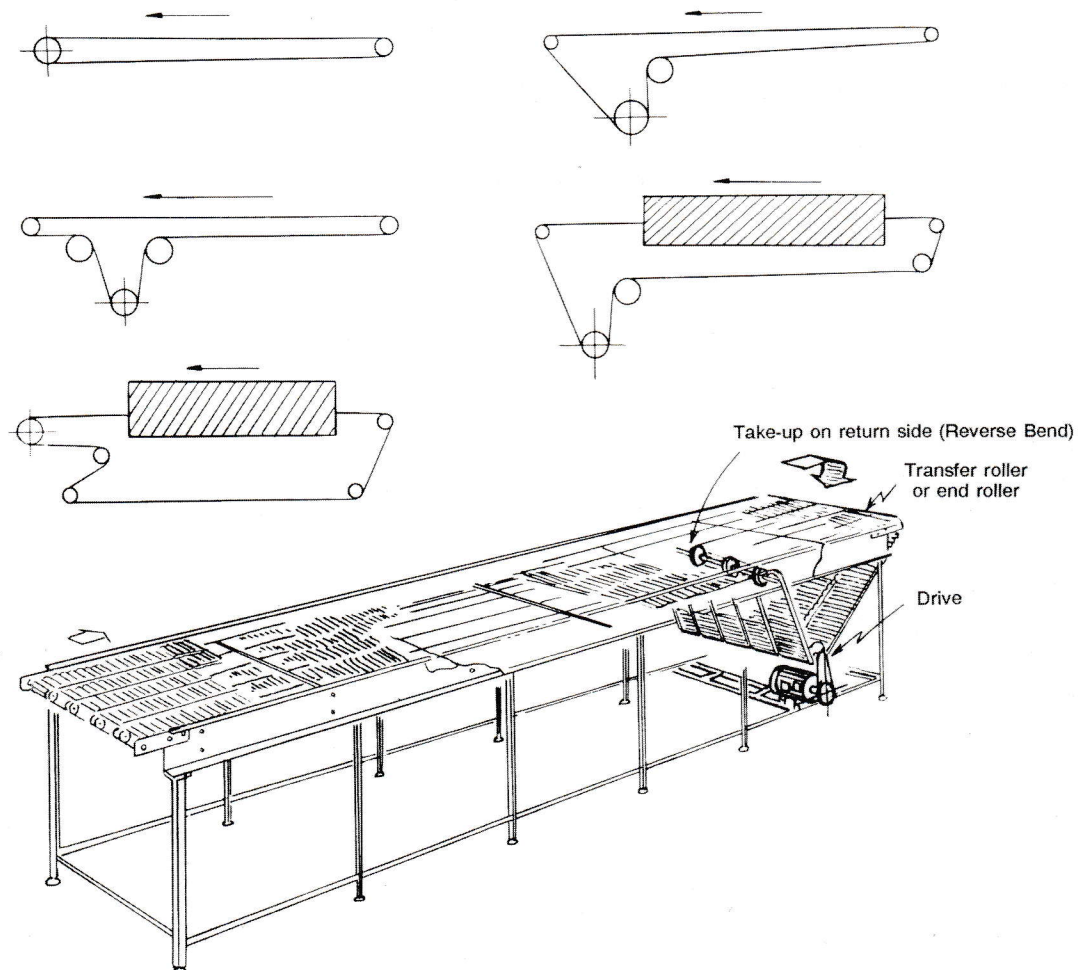

- 3) Consideration must be given to the type and location of belt supports. The most common configuration is round or flat support bars spaced every 4" to 6" across the belt width at locations which do not interfere with the "Z" bends. The supports can be made of stainless steel or various types of plastic such as UHMW. See Diagram #1.

Another common support system, often recommended for longer conveyors, is one made up of free turning rollers placed at 6" to 12" intervals.

In some cases, it is desirable to have a slider bed on the top pass and a roller support on the return pass in order to get maximum product support and minimum belt pull. See Diagram #2.

DIAGRAM #1

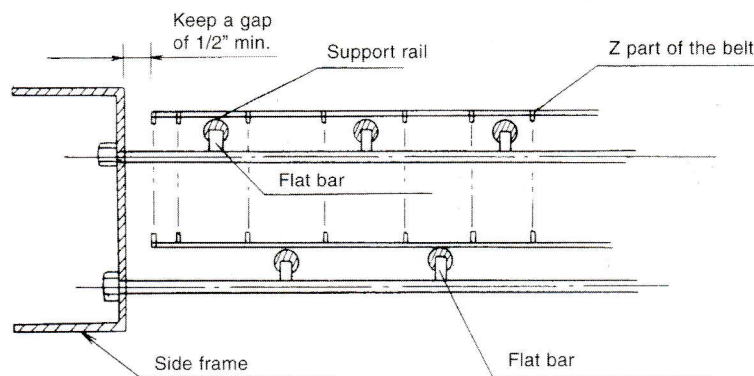
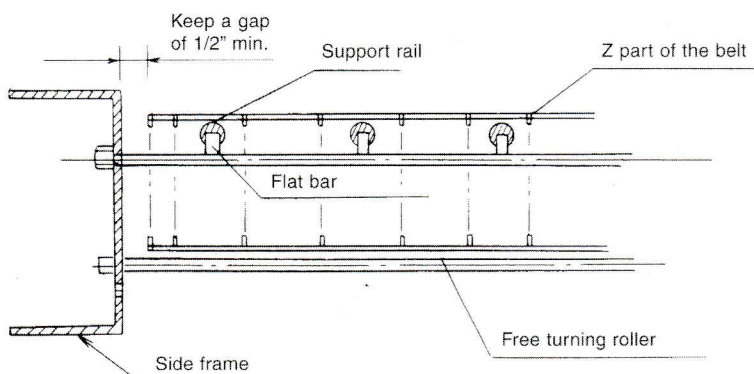

DIAGRAM #2



LOCATION OF SPROCKETS, TAKE UPS, AND TRANSFERS

The following Diagrams show the correct way to locate the (1) Drive Sprockets, (2) Transfer Rolls, (3) Take-Up Rolls.

3 SPACES

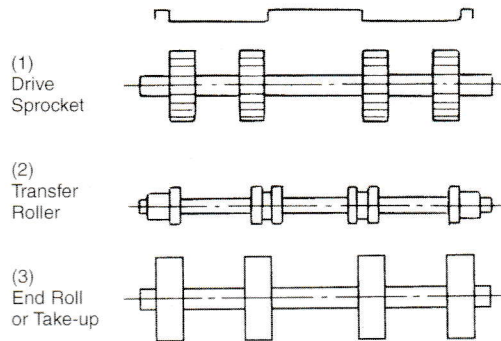

5 SPACES

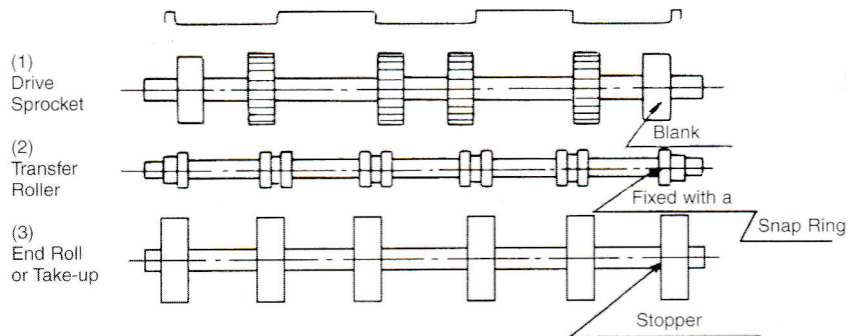

7 SPACES OR MORE

