



A warm hearted supplier

山东联润机械设备有限公司  
SHANDONG LIANRUN MACHINERY CO, LTD

Trusted Manufacturer & Exporter of Industrial Ventilation  
and Modern Farm Equipment Solutions

CONTACT

+8618806362979 - +8613869685958  
0536-3512888 0536-3512888  
rfelix@126.com 262500  
rfancompany.com  
lianrunpoultryfan.en.alibaba.com

MANAGER

FELIX CHENG  
+8618806362979



Wechat



WhatsApp

ADDRESS

山东省潍坊市青州市  
经济技术开发区  
康圣路与华龙路交叉口西北  
Northwest Of Intersection Of  
Kangsheng Road And Hualong Street,  
Qingzhou Economic Development  
Zone, Weifang, Shandong, China.

FOLLOW US

Rfan Ventilation System &  
Poultry Equipment  
Rfan\_Poultry\_Equipment

COMPANY  
CATALOGUE



A warm hearted supplier

山东联润机械设备有限公司  
SHANDONG LIANRUN MACHINERY CO, LTD

Global Ventilation & Farm Equipment  
Manufacturing Solutions

品质可靠  
RELIABLE QUALITY

技术先进  
ADVANCED TECHNOLOGY

经久耐用  
DURABLE AND STURDY

贴心服务  
ATTENTIVE SERVICE





## 公司简介

山东联润机械设备有限公司坐落在风景秀丽的青州市，厂址位于青州市经济开发区康圣路与华龙街交叉口，交通方便，地理位置优越。

本公司是生产温控设备和养殖设备的专业厂家，集设计研发，生产，安装，销售，售后服务于一体。产品种类多，规格全，主要产品有：温室、厂房用大型风机，负压风机，畜牧风机，牛舍悬挂式专用风机，冷风机，湿帘纸，湿帘墙，平养鸡水线料线，笼养设备，养猪自动化水线料线等60余系列200多个规格品种。产品广泛应用于农业，温室，畜牧业，各类厂房，商场超市等行业。

本公司始终秉承：忠诚守信、客户至上、质量第一、创新改进的企业理念，同时坚持信为本、诺为荣、重合同、保质量、精服务的企业运营宗旨，我们愿与国内外广大有识之士广泛合作，共谋发展，共创未来。

## COMPANY PROFILE

SHANDONG LIANRUN MACHINERY CO., LTD. is located in Qingzhou Economic Development Zone, offering a strategic location and convenient transportation.

We specialize in the design, manufacturing, sales, and after sales service of temperature control and poultry equipment. Our product range includes industrial fans, greenhouse ventilation systems, cooling pads, air coolers, automatic drinking and feeding systems, cage equipment, and pig feeding lines, with over 60 product varieties.

Widely applied in agriculture, greenhouses, animal husbandry, factories, and commercial spaces, our products are exported to many countries across Asia, Europe, and Africa. With a commitment to integrity, quality, and continuous innovation, we warmly welcome cooperation with partners worldwide to build a better future together.

# RFC系列推拉式风机

## PUSH - PULL EXHAUST FAN

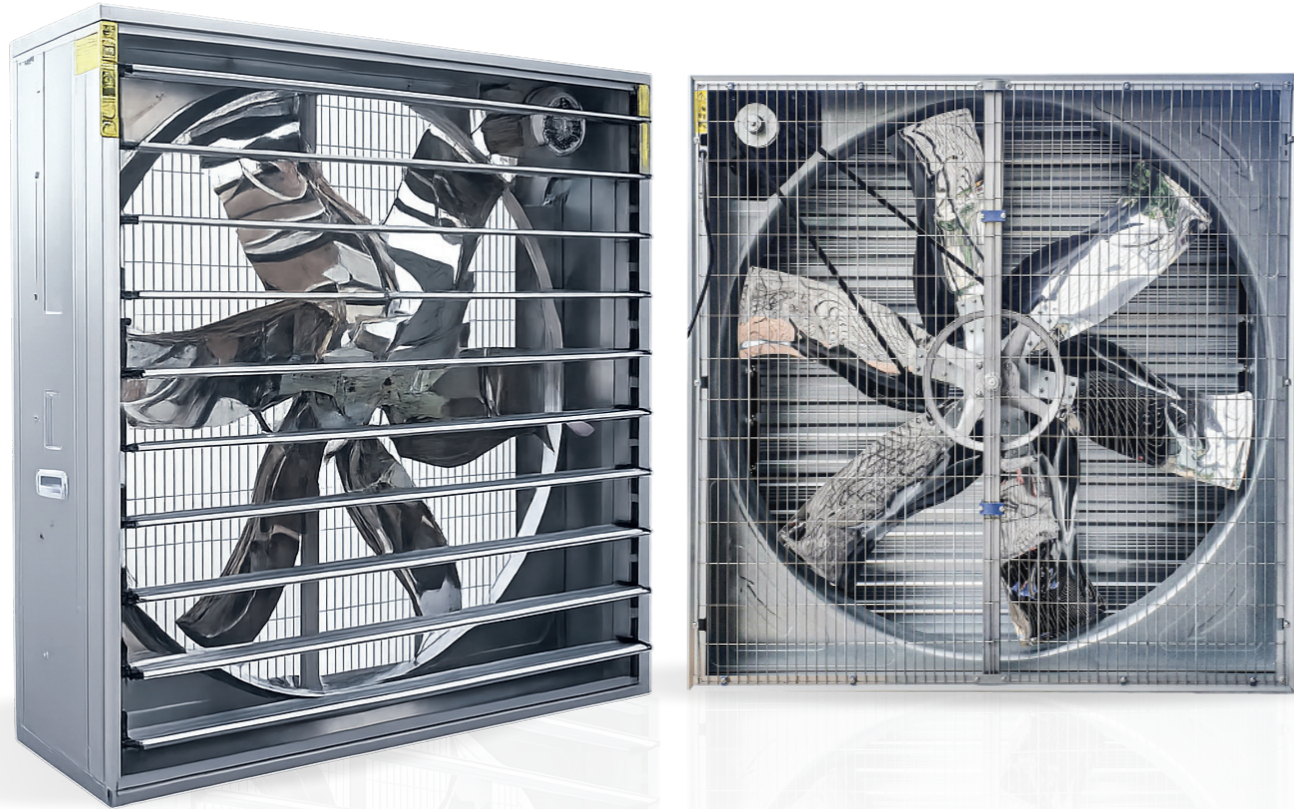

### 构造及原理 | Structure and principle

联润系列高档风机主要由风叶、电机、外框、护网、支撑架及百叶窗组成，采用空气动力学原理设计，有效降低风阻并优化整体性能。主要部件均采用国际加厚镀锌板及不锈钢板，经电脑数控机床一次冲压成型，坚固耐用。产品广泛适用于畜牧养殖场、花卉温室及工业厂房等场所的通风降温。

The RFC High Class Fan features fan blades, a motor, a protective outer frame, safety nets, and shutters operated by a push - pull centrifugal system. Made from galvanized steel (180g - 275g/m<sup>3</sup> zinc coating) and stainless steel, it offers excellent durability, corrosion resistance, and efficient airflow performance with minimized wind resistance. It is widely used in farms, green houses, and factory buildings.

型号规格 Model specifications	风叶直径 Diameter blades (mm)	风叶转速 Blades speed (rpm)	电机转速 Motor speed (rpm)	风量 Air flow (m <sup>3</sup> /h)	全压 Total pressure (Pa)	噪音 Noise decibels (dB)	输入功率 Input power (W)	额定电压 Rated voltage (V)	高 Height (mm)	宽 Width (mm)	厚 Thickness (mm)
RF - 1000C	910 (36")	650	1400	26000	60	≤70	550	380	1000	1000	450
RF - 1100C	1000 (40")	600	1400	33000	70	≤70	750	380	1100	1100	450
RF - 1220C	1100 (43")	440	1400	39500	50	≤70	1100	380	1220	1220	450
RF - 1380C	1270 (50")	440	1400	43500	56	≤70	1100	380	1380	1380	450
RF - 1530C	1400 (55")	420	1400	51000	56	≤75	1500	380	1530	1530	450

### 主要性能特点 | Performance characteristics



风扇叶片是由克虏伯不锈钢冲压成型，无灰尘，美观耐用。特殊的叶片形状设计保证风量，不变形，不断裂。

**Fan Blade:** Composed of Krupp stainless steel, made by punch forming, ensuring no dust. Attractive and durable. The special blade shape design ensures large air volumes, no deformation and a continuous, consistent rate of air flow.



中国著名电机与西门子电机可用。电机的电压和频率可定制。中国著名的汽车公司特殊设计的风扇。有效的解决了电机自身的散热问题，电机防护等级IP55，绝缘等级F。

**Motor:** Available in Chinese brand or Siemens options, with customizable voltage and frequency. Specially designed for fan use with built in power off protection. IP55 protection, Class F insulation.



风扇皮带轮是由高强度铝镁合金的压铸，降低重量，叶轮叶片完整，高耐腐蚀性。加强筋带轮设计。消除内部应力，提高自身的刚度和稳定性，不会破碎。

**Fan Belt Pulley:** Die cast from high strength aluminum magnesium alloy for reduced impeller weight and excellent corrosion resistance. The three rib reinforced design improves rigidity and stability, while the sandblasted finish enhances appearance and reduces the risk of breakage.



风扇轴承采用双列轴承专用防水设计，水不能进入。强度高，噪音低，免维护，使用寿命长。

**Fan Bearing:** Adopts imported double row bearings with special waterproof design, ensuring water does not enter. Exhibits high strength, lower noise, is maintenance free and has a long service life.



推拉机构能完全打开百叶窗，保证了最小的空气阻力和最大风量。当关闭时，能有效的防风、防雨、防尘。采用优质尼龙材料注塑加工。推拉机构都是由铜铆钉紧固，耐磨、不生锈，灵活。导杆使用了304不锈钢，确保了高强度，不生锈，减少摩擦。

**Centrifugal System:** Opens to a full 90° for minimal air resistance and maximum airflow. When closed, it effectively blocks light and wind. Made from high - quality nylon with copper rivets and 304 stainless steel guide rods for excellent durability, flexibility, and water/dust resistance.



# RFB系列重锤式风机

## SERIES HEAVY HAMMER EXHAUST FAN

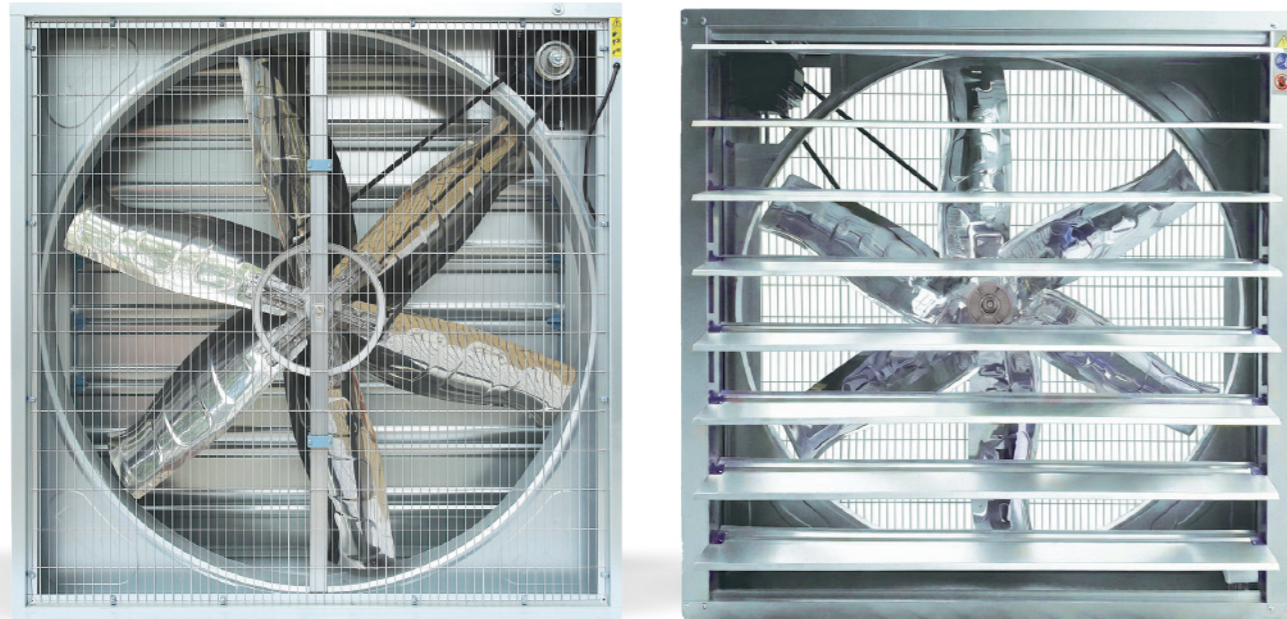

### 构造及原理 | Structure and principle

风机主要由风叶、电机、外框、护网、支撑架、百叶窗等部件组成。电机驱动风叶产生气流，活动百叶窗型式可按用户需要配备，开机后百叶窗可自动开启，停机时百叶窗自动闭合，以防室外灰尘、异物等进入。亦可避免雨雪及倒风的影响。

The RFB Fan is mainly composed of a blade, motor, outer frame protecting nets and supporting frames and shutters. The motor drives blade to cause air flow and shutters can open and close automatically to keep the dust from entering. The major parts are made of galvanized steel sheets and stainless steel sheets.

型号规格 Model specifications	风叶直径 Diameter blades (mm)	风叶转速 (转/分) Blades speed (rpm)	风量 Air flow (m³/h)	全压 Total pressure (Pa)	噪音 Noise decibels (dB)	电机 - Motor				尺寸 External size 高 x 宽 x 厚 H x W x D (mm)
						功率 W	防护 IP	转速 RPM	电压 V	
RF-600B	450 (18")	1350	7380	60	≤60	180	IP54	1350	220/380	600 x 600 x 370
RF-620B	500 (20")	1350	9960	60	≤70	370	IP54	1350	220/380	620 x 620 x 370
RF-800B	710 (28")	546	22000	60	≤60	370	IP54	1350	220/380	800 x 800 x 400
RF-900B	750 (30")	566	28000	65	≤65	550	IP54	1400	220/380	900 x 900 x 400
RF-1000B	900 (30")	566	30000	62	≤70	750	IP54	1400	220/380	1000 x 1000 x 400
RF-1100B	1000 (40")	488	32500	70	≤70	750	IP55	1400	220/380	1100 x 1100 x 400
RF-1220B	1100 (43")	395	38000	73	≤70	1100	IP55	1400	220/380	1220 x 1220 x 400
RF-1380B	1250 (50")	418	44000	56	≤75	1100	IP55	1400	220/380	1380 x 1380 x 400
RF-1530B	1400 (55")	418	55800	60	≤70	1500	IP55	1400	220/380	1530 x 1530 x 400

### 主要性能特点 | Performance characteristics



风扇叶片是由克虏伯不锈钢冲压成型，无灰尘，美观耐用。特殊的叶片形状设计保证风量大，不变形，不断裂。

**Fan Blade:** Composed of Krupp stainless steel, made by punch forming, ensuring no dust. Attractive and durable. The special blade shape design ensures large air volumes, no deformation and a continuous, consistent rate of air flow.



中国著名电机与西门子电机可用。电机的电压和频率可定制。中国著名的汽车公司特殊设计的风扇。有效的解决了电机自身的散热问题，电机防护等级IP55，绝缘等级F。

**Motor:** Available in Chinese brand or Siemens options, with customizable voltage and frequency. Specially designed for fan use with built in power off protection. IP55 protection, Class F insulation.



风扇皮带轮是由高强度铝镁合金的压铸，降低重量，叶轮叶片完整，高耐腐蚀性。加强筋带轮设计。消除内部应力，提高自身的刚度和稳定性，不会破碎。

**Fan Belt Pulley:** Die cast from high strength aluminum magnesium alloy for reduced impeller weight and excellent corrosion resistance. The three rib reinforced design improves rigidity and stability, while the sandblasted finish enhances appearance and reduces the risk of breakage.



风扇轴承采用双列轴承专用防水设计，水不能进入。强度高，噪音低，免维护，使用寿命长。

**Fan Bearing:** Adopts imported double row bearings with special waterproof design, ensuring water does not enter. Exhibits high strength, lower noise, is maintenance free and has a long service life.



采用高强度尼龙百转重锤打开机构，保证百叶窗打开、关闭灵活。

**Drop Hammer:** Using high strength nylon, this swung drop hammer opening device ensures the flexibility of the opening and closing of the shutters.

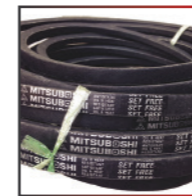

皮带采用进口皮带，确保使用寿命，免维护。

**Belts:** Imported belts that exhibit long service life, ensuring minimal maintenance.



# RFE系列蝴蝶门式拢风筒风机

## SERIES BUTTERFLY TYPE CONE FAN

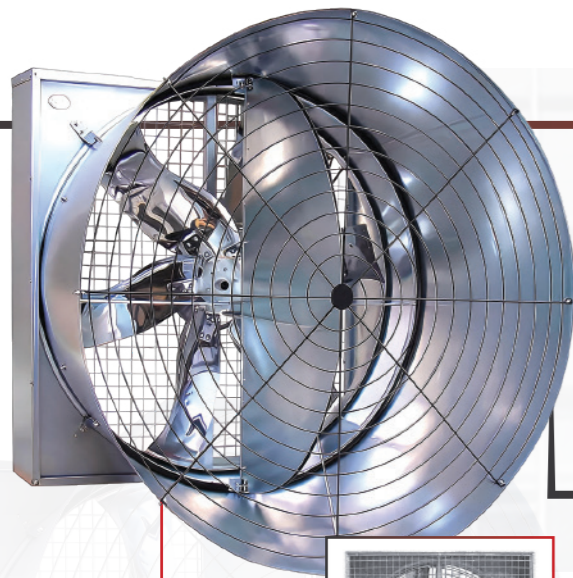

采用先进前置双门打开机构, 风阻小, 密闭好, 效率高; 加长喇叭口设计提高抽风压力。

Using an advanced front double door opening device, small wind resistance, good sealing, and high efficiency are provided. A lengthened cone design helps improve exhaust power.

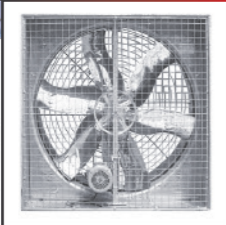

外框镀锌板均采用275g/m<sup>2</sup>, 180g/m<sup>2</sup>镀锌板, 有效避免生锈。

Galvanized steel frame: made of 275g/m<sup>2</sup> or 180g/m<sup>2</sup>. Provides rust protection.

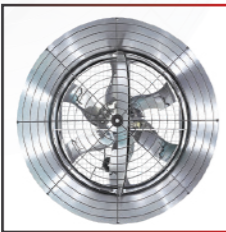

风机双门关闭时加有橡胶密封装置。当多台风机根据环境情况, 不同时启动时, 有效避免空气回流, 大大提高运行效率。与同功率风机相比, 提高效率15 - 20%。

Rubber sealed double doors effectively prevent air backflow during staggered fan operation, improving efficiency by 15 - 20% compared with fans of the same power.



联润风机特殊的风扇形状设计使其可自行清洁以达到最高效率。扇叶采用克虏伯自洁不锈钢材料经模具冲压成型制成, 风量大、不变形、不断裂、不挂灰、美观耐用; 不锈钢厚度: 1.2mm, 表面光洁度: BA。

Precision stamped from Krupp stainless steel for top grade efficiency, delivering large airflow with excellent durability and no deformation. Thickness: 1.2 mm; BA surface finish.

型号规格 Model specifications	风叶直径 Diameter blades (mm)	风叶转速 Blades speed (rpm)	电机转速 Motor speed (rpm)	风量 Air flow (m <sup>3</sup> /h)	全压 Total pressure (Pa)	噪音 Noise decibels (dB)	输入功率 Input power (W)	额定电压 Rated voltage (V)	高 Height (mm)	宽 Width (mm)	厚 Thickness (mm)
RF-1000E(36")	910	600	1400	31000	70	≤70	550	380	1000	1000	1180
RF-1380E(50")	1270	439	1400	51000	80	≤70	1100	380	1380	1380	1300

# RFL系列百叶式拢风筒风机

## SERIES SHUTTER CONE FAN

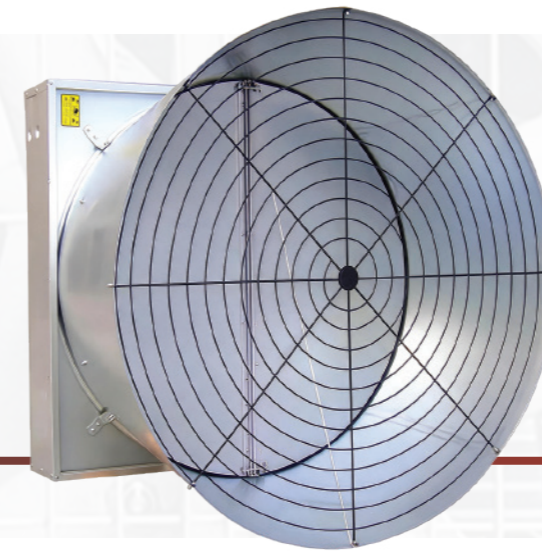

### 性能特点 | Performance characteristics

外框材料采用先进的自动化设备加工而成的镀锌板, 每平方米镀锌层厚度为275克或180克。

Frame: Hot - dip galvanized steel, 275 g/m<sup>2</sup> zinc coating

新颖合理的喇叭口设计, 可以聚集风量和集中风向, 风量更大, 更节能降噪。

Cone Design: Higher airflow, lower noise, energy efficient

风机由6片材质430BA面不锈钢组成, 通过严格的动平衡测试, 使叶片之间的差距小于1g。

430 BA Blade Model: 6 stainless steel blades, balance tested for stability



型号规格 Model specifications	风叶直径 Diameter blades (mm)	风叶转速 Blades speed (rpm)	电机转速 Motor speed (rpm)	风量 Air flow (m <sup>3</sup> /h)	全压 Total pressure (Pa)	噪音 Noise decibels (dB)	输入功率 Input power (W)	额定电压 Rated voltage (V)	高 Height (mm)	宽 Width (mm)	厚 Thickness (mm)
RF-1000L(36")	900	600	1400	23000	65	≤65	550	380	1000	1000	1100
RF-1380L(50")	1250	439	1400	44000	80	≤70	1100	380	1380	1380	1250

# RFA系列重锤式直联风机

## SERIES DIRECT MOTOR HAMMER FAN

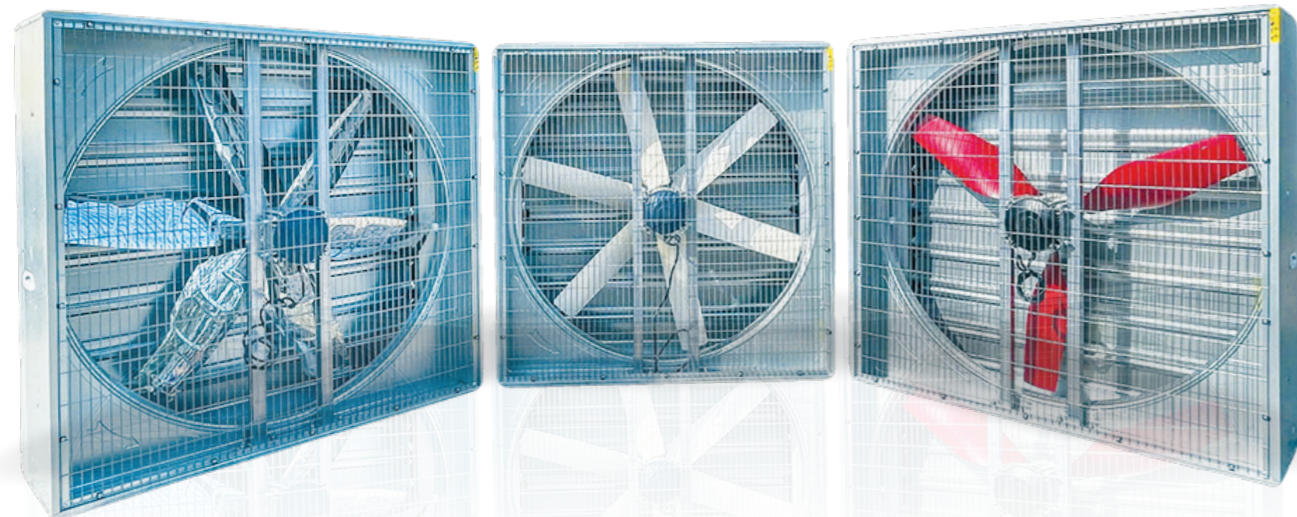

### 性能特点 | Performance characteristics

6片430不锈钢扇叶美观耐用, 通过动平衡测试, 风量, 噪音低, 不变形, 不断裂。  
每个电机100%单独测试质量控制。  
电机直接驱动, 避免了因皮带传动造成的功率损耗, 效率更高, 风量更大, 噪音更低。  
省去了皮带轮、皮带、轴承等部件, 使用中维护更方便省心。

6 - blade 430 BA stainless steel propeller, balance tested for low noise & vibration.  
100% motor quality control, individually tested.  
Direct drive system for higher efficiency & larger airflow.  
Low maintenance, no belt, pulley, or bearing required,

型号规格 Model specifications	风叶直径 Diameter blades (mm)	风叶转速 (转/分) Blades speed (rpm)	风量 Air flow (m³/h)	全压 Total pressure (Pa)	噪音 Noise decibels (dB)	电机 - Motor		尺寸 External size 高 x 宽 x 厚 H x W x D (mm)
						功率 W (Pole)		
RF-800A	710	650	20000	60	<70	550 (10P)		800 x 800 x 450
RF-900A	800	630	22000	65	<70	550 (10P)		900 x 900 x 450
RF-1000A	900	610	25000	70	<70	750 (12P)		1000 x 1000 x 450
RF-1100A	1000	600	32500	70	<70	750 (12P)		1100 x 1100 x 450/500
RF-1220A	1100	460	38000	73	<70	750 (12P)		1220 x 1220 x 450/500
RF-1380A	1250	440	44000	56	<70	1100 (12P)		1380 x 1380 x 450/500

# RF系列玻璃钢风机

## SERIES FRP FAN



### Product features:

Fiberglass fan is widely used in corrosive gas place like piggery farm, poultry farm and peculiar smell workshop, which like textile mill, shoe factory, furniture factory and so on.

Patented design with excellent performance, easy cleaning, low maintenance, and over 10 years of service life.

SMC housing with thick, corrosion resistant, rust free construction, glossy finish, and low maintenance.

Balanced 6 SMC blades for high performance, smooth operation, and easy assembly.

Direct drive fan requiring no belts, no bearings to grease with high efficiency with no drive loss.

Special shutter design lower resistance with preventing back drafts.

型号规格 Model specifications	扇叶直径 Propeller Dia. mm/(Inch)	额定转速 Rated Speed (R/min)	风量 Air flow (m³/h)	额定功率 Rated Power (Kw)	噪音 Noise decibels (dB)	电压参数 Voltage Frequency/Phase	尺寸 Complete Size	
							LXHXW(mm)	带喇叭口尺寸 Size With Cone LXHXW(mm)
RF-1460	1240/(50")	520	36000	1.1	60-70	380V/220V 50HZ/60HZ 3/1	1460 x 1460 x 590	1460 x 1460 x 1270
RF-1260	1080/(42")	520	32000	0.75	60-70		1260 x 1260 x 560	1260 x 1260 x 1200
RF-1060	890/(36")	520	19000	0.55	60-70		1060 x 1060 x 560	1060 x 1060 x 1160
RF-850	640/(24")	700	9500	0.37	60-70		850 x 850 x 450	850 x 850 x 950
RF-660	480/(18")	950	6500	0.37	60-70		660 x 660 x 450	660 x 660 x 780
RF-560	380/(15")	950	5500	0.25	60-70		560 x 560 x 450	

Option configuration	型号规格 Model specifications	扇叶直径 Propeller Dia. mm/(Inch)	扇叶数量 Blade quantity	扇叶材质 Blade Material	额定转速 Rated Speed (R/min)	风量 Air flow (m³/h)
	RF-1460	1260/(50")	6	不锈钢 Stainless steel	520	41000
		1250/(48")	6	玻璃钢 Fiberglass	520	37000
		1250/(50")	3	压铸铝 Cast aluminum	620	42000

# RF系列玻璃钢风机

## SERIES INDIRECT MOTOR FRP FAN

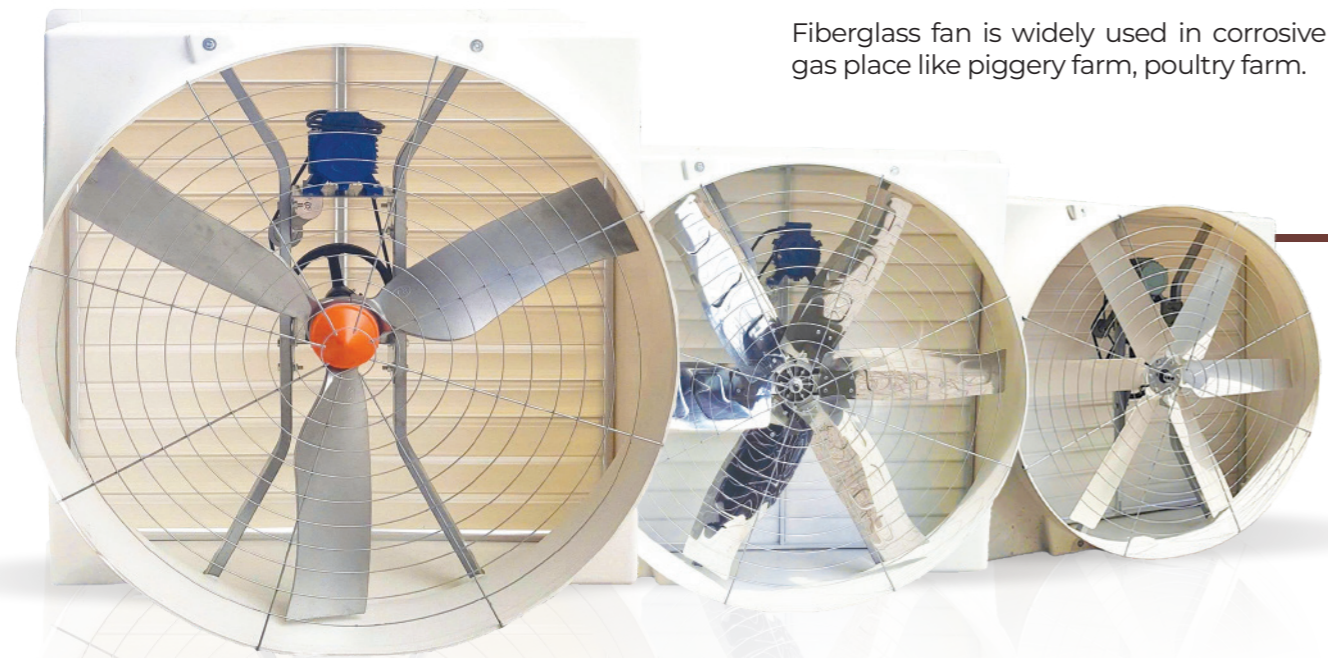

Fiberglass fan is widely used in corrosive gas place like piggery farm, poultry farm.

### Product Features:

UV resistant fiberglass housing.  
Fiberglass cone standard on all fans, can improve 10% efficiency.  
Aluminum blade High technology, reduce the noise.

High quality imported pillow block bearings.  
Automotive style belt tensioner.  
Higher quality motor will be available.

型号规格 Model specifications	风机尺寸 Inch	扇叶直径 Propeller Dia. (mm)	铸铝扇叶 Aluminum blade	额定转速 Rated Speed (R/min)	风量 Air flow (m³/h)	额定功率 Rated Power (Kw)	电压参数 Voltage Frequency/Phase	驱动方式 Drive Mode	尺寸 Complete Size	
									LXHXW(mm)	LXH(mm)
RF-1630	55"	1390	3	548	54300	1.5	380V/220V 50HZ/60HZ	皮带 Belt	1630 x 1630 x 1470	1540 x 1540
RF-1530	51"	1290	3	600	46000	1.1		皮带 Belt	1530 x 1530 x 1220	1460 x 1460
			3	646	47500	1.5		皮带 Belt	1530 x 1530 x 1220	1460 x 1460
RF-1460	50"	1250	3	600	44000	1.1		皮带 Belt	1460 x 1460 x 1270	1400 x 1400
RF-1170	36"	915	3	924	24500	0.75		皮带 Belt	1170 x 1170 x 1200	1080 x 1080
RF-810	24"	650	4	920	12000	0.37		直联 Direct	810 x 810 x 1000	740 x 740
RF-660	18"	460	5	1400	7400	0.25		直联 Direct	660 x 660 x 780	580 x 580

扇叶材质:PG扇叶

Blade material: Nylon

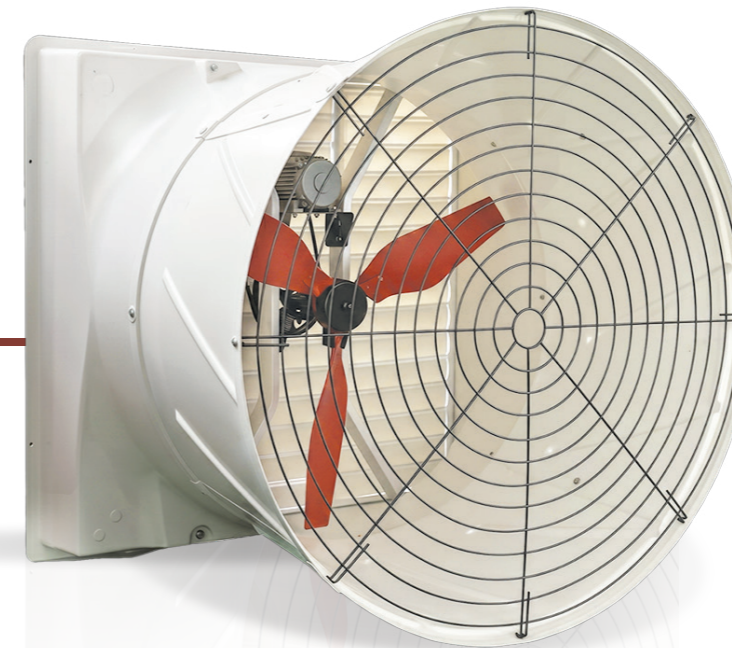

皮带传动系统  
Belt model

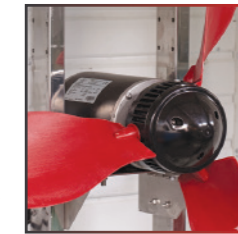

直联传动系统  
Motor direct model



高效电机  
High quality motor

### Product Features:

UV resistant fiberglass housing.

Fiberglass cone standard on all fans, can improve 10% efficiency.

High quality imported pillow block bearings.

Automotive style belt tensioner.

PG Blades: Propeller designed blades made from fiber reinforced composite material, offering high strength, toughness, low bearing wear, reduced maintenance costs, and lower energy consumption.

Higher quality motor will be available.

型号规格 Model specifications	风机尺寸 Inch	扇叶直径 Propeller Dia. (mm)	铸铝扇叶 Nylon blade	额定转速 Rated Speed (R/min)	风量 Air flow (m³/h)	额定功率 Rated Power (Kw)	电压参数 Voltage Frequency/Phase	驱动方式 Drive Mode	尺寸 Complete Size	
									LXHXW(mm)	LXH(mm)
RF-1630	55"	1390	3	626	54800	1.5	380V/220V 50HZ/60HZ	皮带 Belt	1630 x 1630 x 1470	1540 x 1540
RF-1530	51"	1290	3	600	46000	1.1		皮带 Belt	1530 x 1530 x 1220	1460 x 1460
			3	646	47500	1.5		皮带 Belt	1530 x 1530 x 1220	1460 x 1460
RF-1460	50"	1250	3	600	44000	1.1		皮带 Belt	1460 x 1460 x 1270	1400 x 1400
RF-1170	36"	915	3	820	26000	0.75		皮带 Belt	1170 x 1170 x 1200	1080 x 1080
RF-810	24"	650	6	920	12000	0.37		直联 Direct	810 x 810 x 1000	740 x 740
RF-660	18"	460	8	1400	7400	0.37		直联 Direct	660 x 660 x 780	580 x 580

# RFN系列悬挂风机

## HANGING EXHAUST FAN

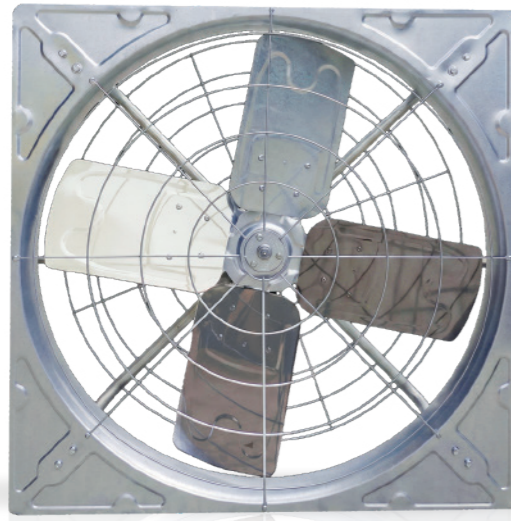

四扇叶牛舍悬挂式风机

### 4 Blades cow house hanging fan

叶片采用专用镜面不锈钢冲压成型制成, 风量大, 不变形、不断裂, 不挂灰, 美观耐用。

风机导流罩采用镀锌层...克/平方, 增加了镀锌层厚度, 保证今后使用不生锈; 采用外翻边倒流设计, 提高通风量, 减少风机振动和噪音, 增加风机稳定性。

扇叶均经过先进的电脑动平衡测试仪校正, 使风机运行平稳、降低噪音、增强稳定性、延长使用寿命。

电机采用铝镁合金外壳, 散热性好, 效率高、电机尺寸小、重量轻、电流低、力矩大。

型号规格 Model specifications	风叶直径 Diameter blades (mm)	额定电压 Rated voltage (V)	级数 Pole	频率 Frequency (Hz)	输入功率 Input power (W)	风量 Air flow (m <sup>3</sup> /h)
RF-1100NS	1000	380	6	50	530	19800

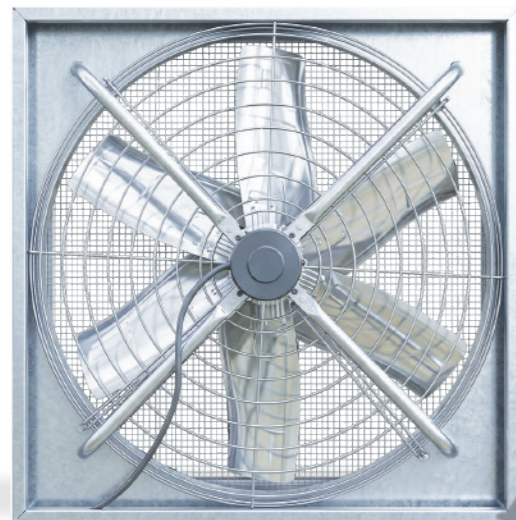

六扇叶牛舍悬挂式风机

### 6 Blades cow house hanging fan

Mirror finish stainless steel blades provide large airflow, durability, and dust resistance.

The galvanized fan shroud improves ventilation, reduces noise and vibration, and enhances stability.

Dynamically balanced blades ensure smooth, quiet operation and long service life.

The aluminum magnesium motor housing offers efficient heat dissipation, high efficiency, and strong torque.

型号规格 Model specifications	风叶直径 Diameter blades (mm)	风叶转速 Blades speed (rpm)	电机转速 Motor speed (rpm)	风量 Air flow (m <sup>3</sup> /h)	全压 Total pressure (Pa)	噪音 Noise decibels (dB)	输入功率 Input power (W)	额定电压 Rated voltage (V)	高 Height (mm)	宽 Width (mm)	厚 Thickness (mm)
RF-1000N	900	600	600	23000	56	≤60	550(10P)	380	1000	1000	350
RF-1100N	1000	550	550	32500	56	≤60	550(10P)	380	1100	1100	350
RF-1220N	1100	440	440	38000	56	≤60	750(12P)	380	1220	1220	350
RF-1380N	1250	440	440	42000	56	≤60	1100(12P)	380	1380	1380	350

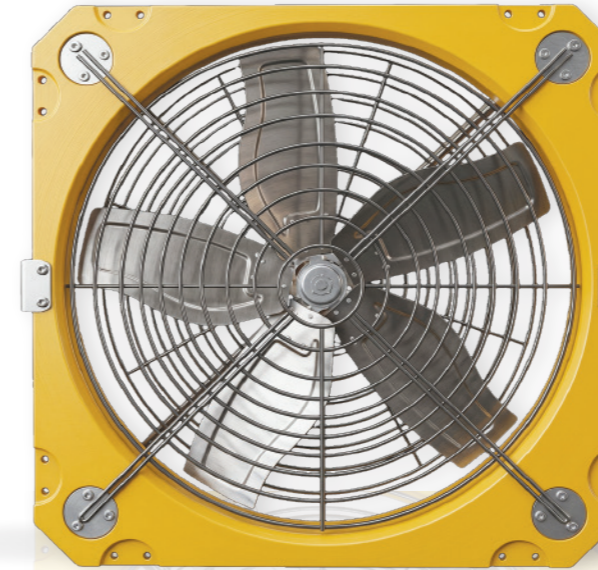

塑料防腐牛舍悬挂式风机

### Plastic cow house hanging fan

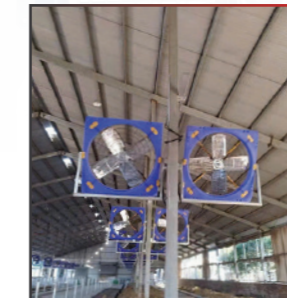
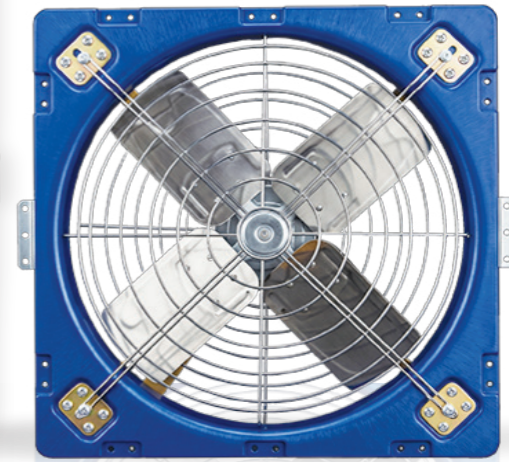

外壳采用一次成型注塑工艺, 强度高, 持久防腐, 超长使用寿命。

电机直接与扇叶连接, 使电机动力传输更加高效。连接更加牢固, 没有了皮带磨损, 使用更方便。有效减少了动力传输的中间环节, 运行更加平稳, 有效风量更大。

Injection molded housing with high strength, corrosion resistance, and long service life.

Direct motor to blade connection for higher transmission efficiency. No belt wear, ensuring more convenient use. Stable operation with larger effective airflow.

型号规格 Model specifications	风叶直径 Diameter blades (mm)	风叶/片 Wind leaf /piece	额定电压 Rated voltage (V)	级数 Pole	电机转速 Motor speed (rpm)	输入功率 Input power (W)	风量 Air flow (m <sup>3</sup> /h)	高 Height (mm)	宽 Width (mm)	厚 Thickness (mm)
RF-1100NP	1000	4	380	8	680	450	30000	1220	1220	350
RF-1220NP	1100	5	380	8	680	450	39000	1330	1220	350

# RF系列赛科龙风机

## SECRON FAN

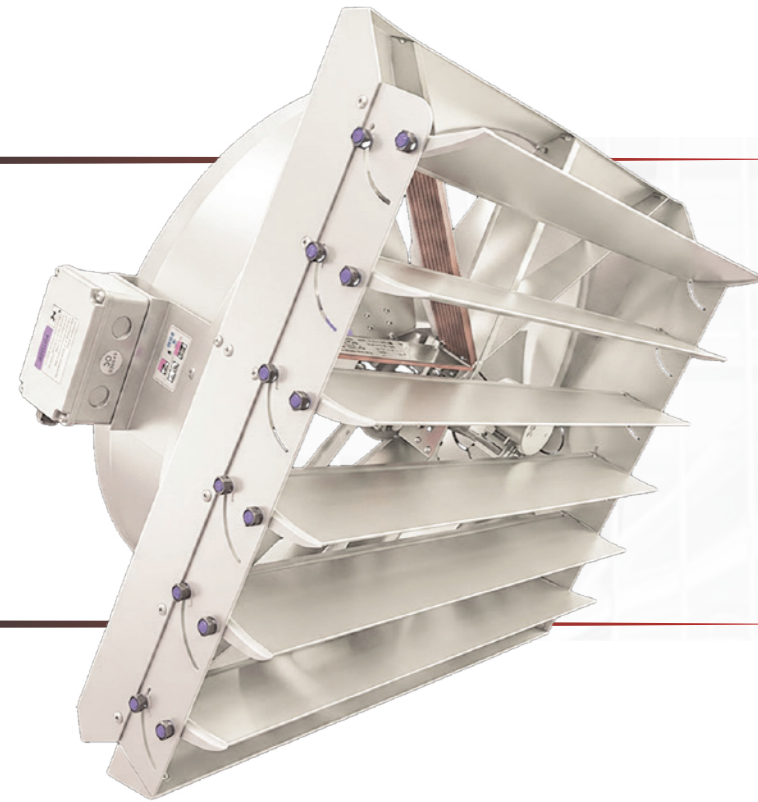

### 主要性能特点 | Performance Characteristics

外壳采用耐腐蚀的玻璃钢材质。  
传动系统采用重载型皮带轮和轴承。  
电机无需维护。  
能够安装在钢制立柱，结构立柱上，或悬挂在天花板上(可选)。  
可选变频驱动。  
72英寸赛科龙风机采用6块导流板，用于定向气流。  
6片耐腐蚀、重载型铝制扇叶。  
降温能耗减少50%。

Focused airflow for fresh air circulation.  
Heavy galvanized motor mount for stable airflow.  
High performance fiberglass intake cone.  
Precision balanced 72" corrosion resistant aluminum blades.  
Covers up to 15,000 sq ft with low power use.  
Optional VFD for smooth speed adjustment.  
Quiet operation at all speeds.

### 主要技术参数 | Main technical parameters

**工作电压:**380V 风机功率:2.2KW  
**扇叶直径:**72"(1.83m)。  
**转速:**每分钟50转~每分钟300转可调。  
**单向通风覆盖面积约:**360平方米(有效长度约30米,有效宽度约12米)。  
**风速最高可达:**1200(FPM),大于6米/秒(在导流板单向安装状态下,距离风机45米处的风速仍可达300(FPM),大于1.5米/秒)。  
**风量≥93000立方米/小时 整机重量:**170公斤。  
**主机外形尺寸:**2米X2米X1.1米。

**Voltage:** 380V; **Power:** 2.2KW ;**Blade diameter:** 72"(1.83m).  
**Speed:** 50 rpm/min ~ 300 rpm/min can adjustable.  
**One way ventilation cover area:** about 360 (effective length about 30 m, effective width about 12 m).  
**Wind speed max:** 1200 (FPM), more than 6 m/s (in one way installation, wind speed also can be 300 (FPM), more than 1.5 m/s).  
**Air volume ≥ 93000 m<sup>3</sup>/h, net weight:** 170 kg.  
**Size:** 2 m X 2 m X 1.1 m.

# RF系列环流风机

## SERIES CIRCULATION FAN



### 主要性能特点 | Performance Characteristics

电机采用性能卓越的“海尔”三防专用电机。  
国际先进的节能技术及热自动保护系统。  
经过“海尔”实验室360小时破坏性试验。  
轻型铝板冲压扇叶，大角度、风量大、低噪音。  
外壳采用先进的整体集流器设计。  
外壳有不锈钢、钢板喷塑型可选。

Features the excellent "Haier" brand electronics.  
International advanced energy conservation technology tested.  
Light aluminum board punch press fan blazer: exhibits a wide angle, large air pressure and low noise.  
Outer covering is stainless steel. Steel spraying is also available.  
Equipped with beautiful and convenient button type hanging articles.  
Long service life: over 10 years.

型号规格 Model specifications	风叶直径 Diameter blades (mm)	额定电压 Rated voltage (V)	电机转速 Motor speed (rpm)	频率 Frequency (Hz)	输入功率 Input power (W)	风量 Air flow (m <sup>3</sup> /h)
RF-300	300	220 (380)	1400	50	150	2880
RF-400	400	220 (380)	1400	50	250	4180
RF-500	500	220 (380)	1400	50	250	5300
RF-600	600	220 (380)	1400	50	370	6500

# RF系列高强度湿帘

## SERIES COOLING PAD



黑色湿帘  
Black cooling pad

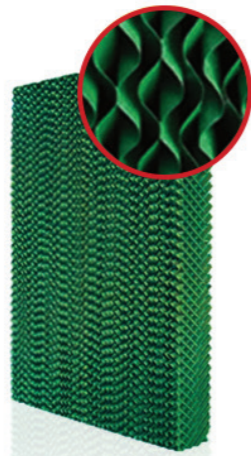

绿色湿帘  
Green cooling pad



褐色湿帘  
Brown cooling pad

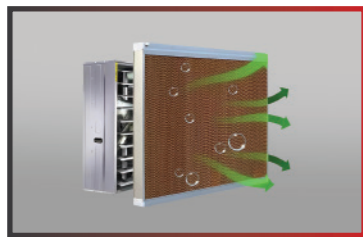

### 主要性能特点 | Performance characteristics

**材质:** 欧洲进口纤维纸, 耐用防霉防蚁  
**降温:** 效率>80%  
**吸水:** 4 - 5秒扩散, 达国际标准  
**安全:** 无苯酚, 环保安全  
**框架:** 镀锌钢/不锈钢/铝合金  
**颜色:** 棕色、绿色、黑色外套

**Material:** European fiber paper, durable, anti mold, anti termite  
**Cooling:** >80% efficiency  
**Absorption:** Fast diffusion (4 - 5s/drop), meets international standards  
**Safety:** Phenol free, safe & eco - friendly  
**Frame:** Galvanized steel/stainless steel/aluminum  
**Colors:** Brown, green, black coats

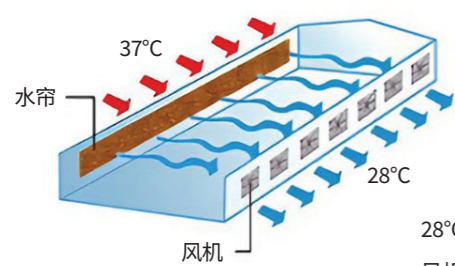

横向水帘降温系统  
Horizontal cooling pad exhaust fan system

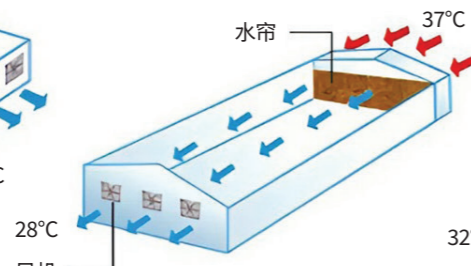

纵向水帘降温系统  
Longitudinal cooling pad exhaust fan system

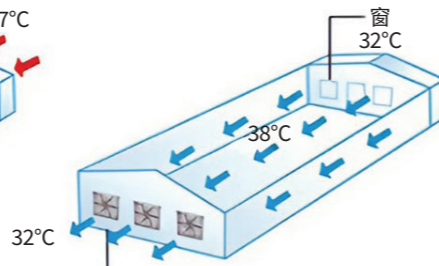

负压抽风机  
Negative pressure fan system

### 规格及说明 | Specifications

	model 7090	model 7060	model 5090
H (mm)	1500, 1800, 2000	1500, 1800, 2000	1500, 1800, 2000
W (mm)	600, 300	600, 300	600, 300
D (mm)	100, 150, 200	100, 150, 200	100, 150, 200
h (mm)	7	7	5
$\alpha$ (*)	45	45	45
$\beta$ (*)	45	15	15

H: Height  
 h: Flute height  
 W: Width  
 $\alpha$ : Across angle (1)  
 D: Thickness  
 $\beta$ : Across angle (2)

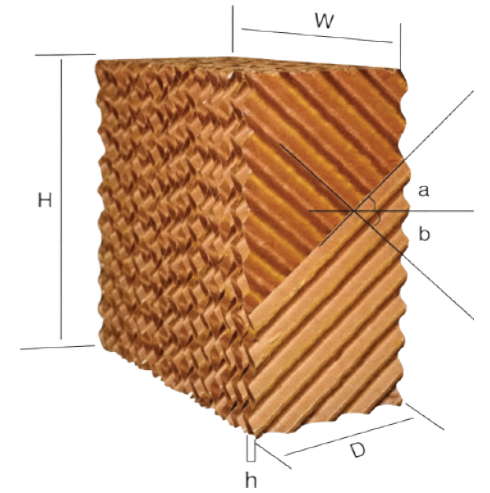

### 安装示意图 | Installation diagram

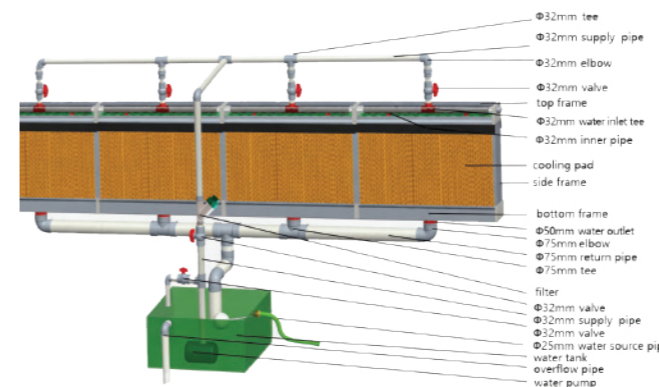

### 应用实例 | Application examples

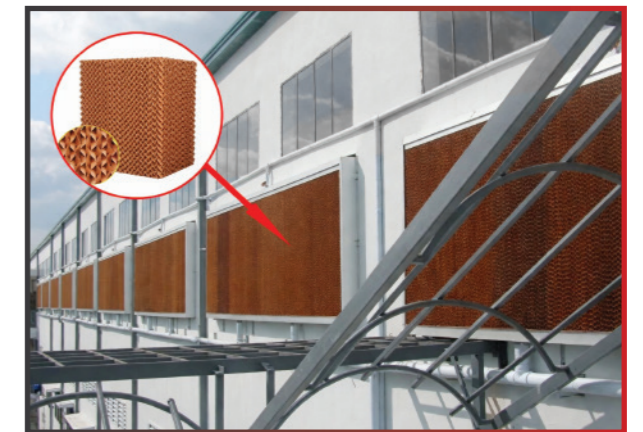

### 湿帘生产线 | Cooling pad production line



# RF系列深水槽

## SERIES DEEP SINK

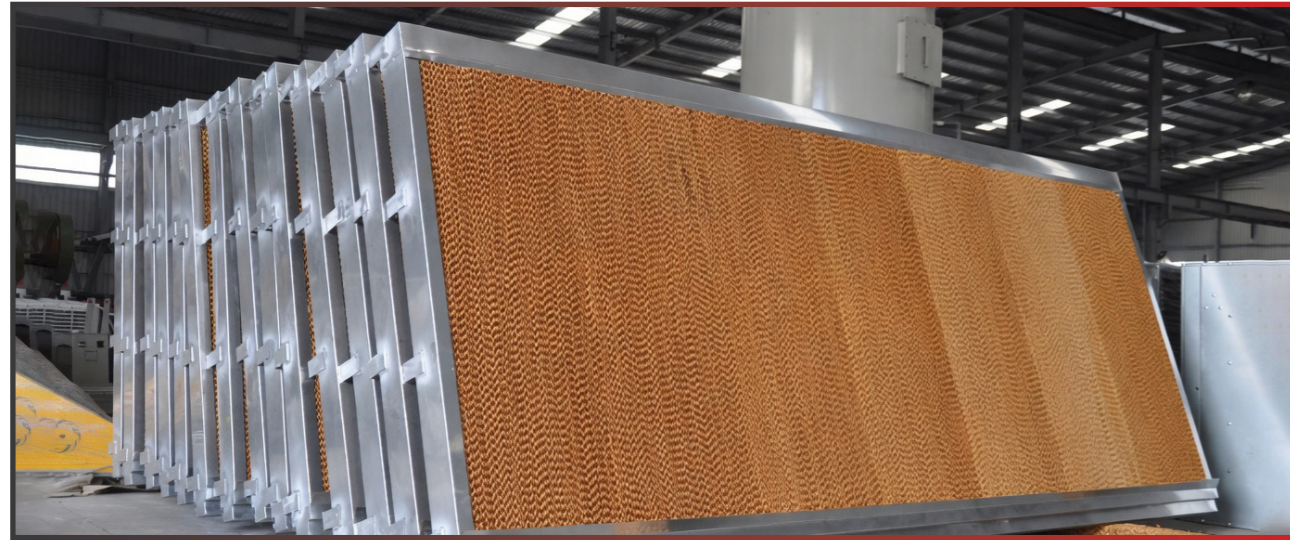

### PVC深水槽的优点 | Performance characteristics

避免循环水的污染。  
方便清理维护。  
省掉单独的循环水池。  
能够迅速产生水分子,提高降温效率。

Avoid the pollution of circulating water.  
Convenient cleaning and maintenance.  
Save a separate circulating pool.  
Can rapidly generate water molecules and improve the cooling efficiency.  
Made of PVC - Galvanized Sheet - Aluminum Alloy

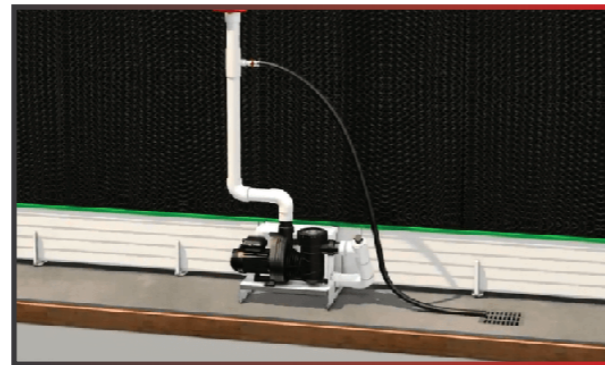

### PVC深水槽的应用实例 | Application example of PVC deep sink



# RF系列冷风机

## SERIES AIR COOLER



### 安装示意图 | Installation diagram

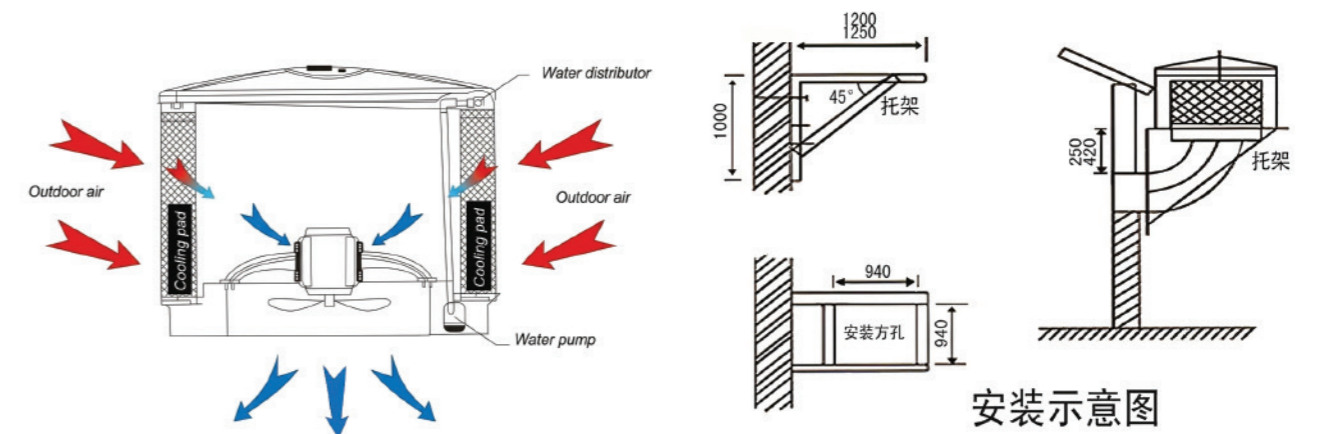

### 技术参数 | Specification

最大风量 Air volume: 18.000 - 25.000 - 30.000 m<sup>3</sup>/h  
适用面积 Applicable area: 90 - 120 m<sup>2</sup>, 100 - 150 m<sup>2</sup>  
电机功率 Power: 1.5KW - 2.2 KW - 3KW  
出风口尺寸 Air outlet size (LxW): 670x670 mm  
风机型式 Fan model: 轴流式 Axial  
储水量 Water storage capacity: 20 - 25 L  
耗水量 Water consumption: 5 - 10 L  
噪音 Noise: 56 - 71 分贝/dB  
电压 Voltage: 380V/50HZ  
重量 N.W: 55Kg - 70Kg  
外形尺寸 Size (LxWxH): 1100x1100x950mm  
1170x1170x1150mm  
1280x1280x1170mm

### 广泛适用于 | Applications

广泛适用于:纺织、服装、注塑、铸造、玩具、印刷、电子、洗衣房、锅炉房等有高温的工业厂房;商场、超市、候车室、酒店、餐厅、医院、学校等公共场所;温室、畜牧、花卉等农业场所。

Suitable for diverse environments: from industrial plants (textile, electronics) and public spaces (malls, hospitals) to agriculture (greenhouses, livestock).

# RF 系列通风窗

## SERIES AIR INLET

### 性能特点 | Performance characteristics

采密封严密, 侧开安装, 长度可任意定制。  
采用聚乙烯、ABS、全新料, 三种材质, 可任意定做。

Seal tight, side open installation, length can be customized.  
PE, ABS, and other materials available, made to order.



### 畜牧养殖用侧墙通风窗——自动开启型 Side wall ventilation window for animal husbandry - Automatic opening type



### 吸顶通风窗 | Cross wind window

采用 ABS 与 PVC 材质, 双层保温, 抗腐蚀耐老化。封闭严密, 开启自如, 长度可定制。

Made of ABS & PVC with double layer insulation. Corrosion resistant, airtight, and easy to operate. Custom lengths available.



# RF 遮光罩

## LIGHT SHIELD



### 原理示意图:

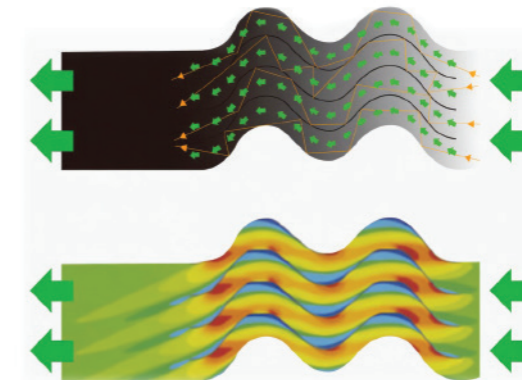

### 组装示意图:

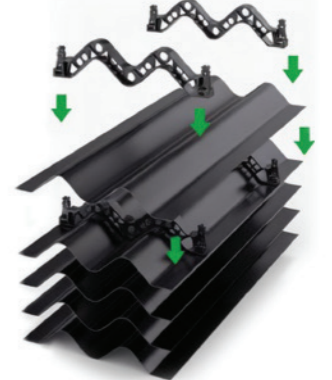

**材质:** 高品质注塑 PVC, 防紫外线、耐化学品、耐高压清洗。

**设计:** 规格多样, 安装简便, 高效遮光且通风顺畅。

**外框:** 不锈钢或镀锌钢可选。易拆洗, 可定制。

**Material:** Injection molded PVC; UV, chemical, and high pressure wash resistant.

**Design:** Modular sizes, easy installation, high light shielding with optimal airflow.

**Frame:** Stainless or Galvanized steel options. Easy to clean and customizable.



型号 Type	尺寸 Size (mm)	重量 Weight (kg)
50" DM-LT	1380x1380x260	59
36" DM-LT	1000x1000x260	27
Air-Inlet on side wall	630x250x250	11

蜂窝结构确保气流顺畅, 最大限度降低压损。

Honeycomb structure ensures maximum airflow and minimum pressure drop.

### 安装示意图 | Installation diagram



# RF 系列料塔

## SERIES SILOS

料塔采用先进生产技术制造,确保产品具备高精度及符合国际标准的稳定性能。整体选用专用户外镀锌钢板,具有优异的耐腐蚀性能和持久耐用的使用寿命。结合先进工艺与独特角度设计,有效提升下料顺畅度,确保饲料输送更加稳定高效。

Produced with advanced technology, silos ensure high precision and stable performance to international standards. Made from dedicated outdoor galvanized steel for superior corrosion resistance and long service life, the unique angle design enables smoother feed discharge.



### 主要参数 | Technical parameter

编号 Item	容量 Capacity (ton)	容量 Capacity (m <sup>3</sup> )	直径 Diameter (mm)	腿子数量 quantity of legs
1	3	4.7	1860	4
2	4.75	7.5	1860	4
3	6.1	9.5	1860	4
4	7.75	11.9	1860	4
5	7.2	11.1	2750	6
6	11	16.9	2750	6
7	14.2	21.8	2750	6
8	17.5	27	2750	6
9	15.5	23.9	3660	8
10	21.5	33.1	3660	8
11	27.5	42.5	3660	8
12	33.8	52	3660	8

NOTE: MATERIAL: 275g galvanized sheet.

# RF 系列称重

## FEED SCALE SYSTEM

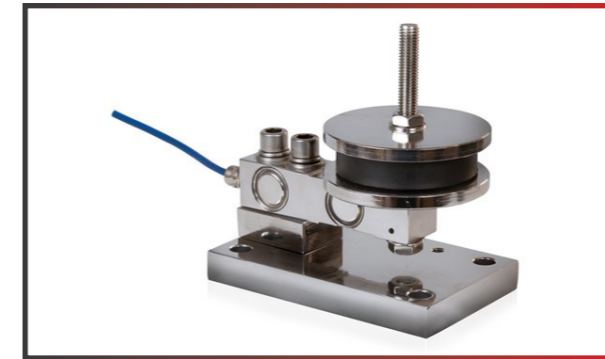

**产品名称:** 柱式称重模块  
**产品规格:** 10T - 50T (可定制特殊规格)  
**精度等级:** C3  
**适用场合:** 高位槽、大型料仓及大型设备称重。  
**安装要求:** 通常每个料仓安装4/6/8只称重模块,配1个接线盒与1个称重仪表。

**Product Name:** Column weighing module  
**Specifications:** 10T - 50T (Customizable)  
**Precision Level:** C3  
**Applications:** High tanks, large silos, and heavy equipment weighing.  
**Installation:** Generally 4, 6, or 8 modules per silo, including 1 junction box and 1 weighing indicator.

### 系列产品—料塔地基图 | Silo foundation drawing parameter

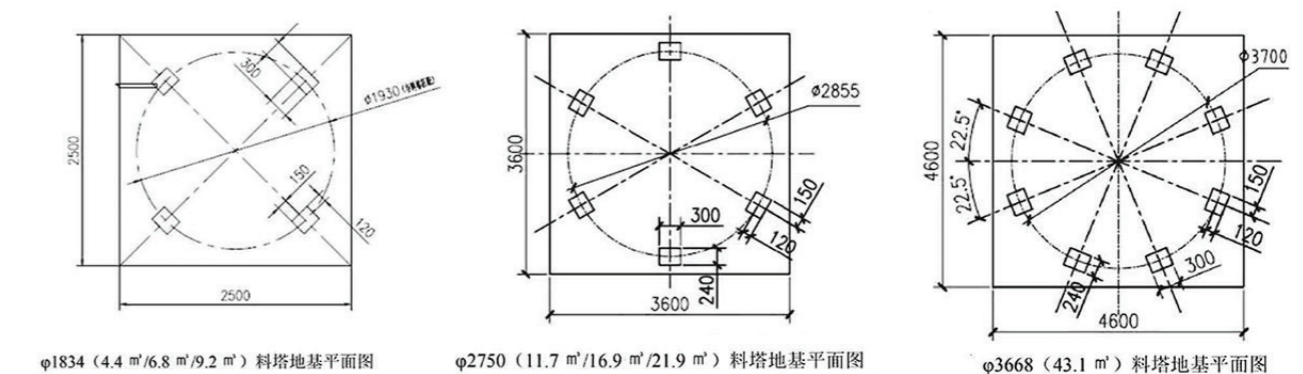

# RF 系列不锈钢猪料槽

## SERIES STAINLESS STEEL PIG FEED TROUGH

单面 / 双面不锈钢猪料槽  
Single / two side stainless steel pig trough

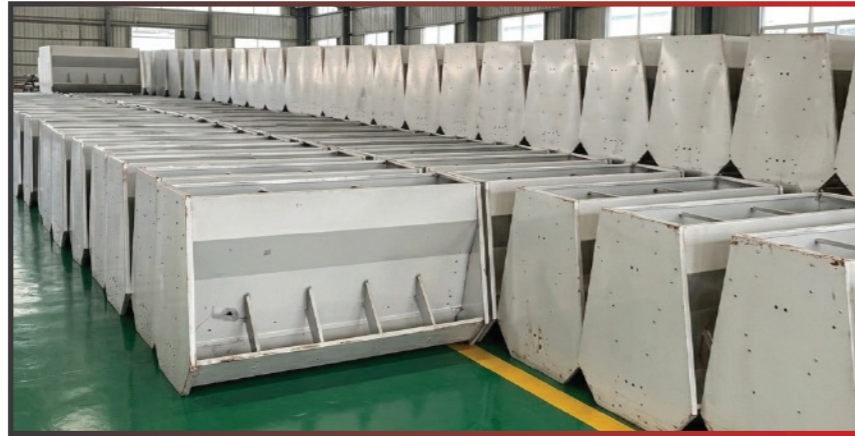

### 主要技术参数 | Technical parameter

分类 Model	育肥双面 Two - side trough for fattening pig					育肥单面 Single - side trough for fattening pig				
	12孔 12 holes	10孔 10 holes	10孔 10 holes	8孔 8 holes	6孔 6 holes	6孔 6 holes	5孔 5 holes	5孔 5 holes	4孔 4 holes	3孔 3 holes
材料 Material	201 SS	201 SS	201 SS	201 SS	201 SS	201 SS	201 SS	201 SS	201 SS	201 SS
尺寸 Size(mm)	1800 x 730 x 900	1500 x 730 x 900	1250 x 730 x 900	1200 x 730 x 900	900 x 730 x 900	1800 x 410 x 900	1500 x 410 x 900	1250 x 410 x 900	1200 x 410 x 900	900 x 410 x 900
净重 Net weight (kg)	70	60	53	50	40	52	44.5	39	37.5	30.8

# RF 系列养猪料线

## SERIES PIG FEED LINE



**养猪设备自动料线构成:**  
主要包含料管、送料绞龙、驱动电机、主料料斗、下料管和感应器、操控设备等。

**Pig automatic feeding line includes:**  
feeding pipe, auger/disk chain, drive motor, main hopper, feed outlet pipe, sensor, and control equipment.

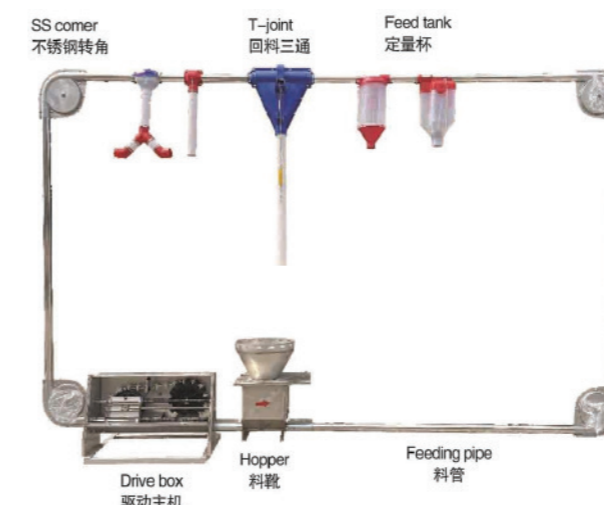

# RF系列定位栏

## SERIES FARROWING CRATE

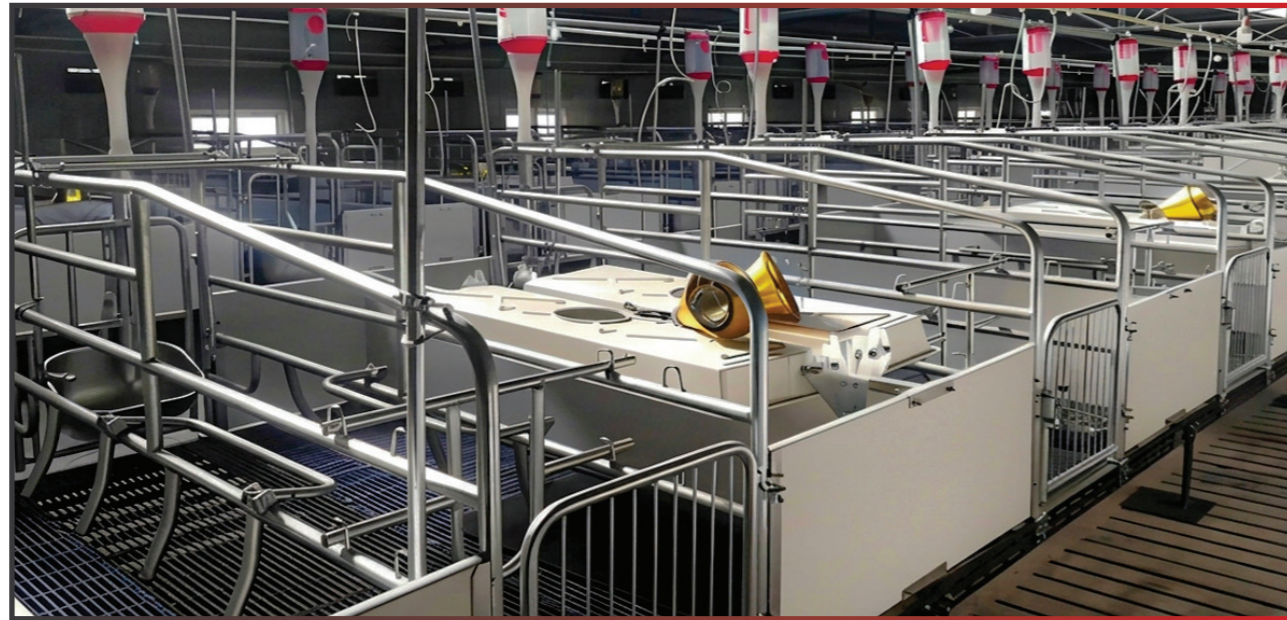

### 产品特点 | Product features

**防腐蚀:** 具有极强的防锈能力。  
**易清洁:** 外观光滑, 清理方便快捷。  
**护栏牢固:** 整体抛丸处理, 有效防止焊缝及酸液腐蚀。  
**安全可靠:** 无锐利棱角; 6mm厚连接板, 结构强度高。  
**调节方便:** 可根据门门高度灵活调节, 锁止效率高。

**Anti-corrosion:** Superior anti rust ability.  
**Easy to clean:** Smooth appearance for effortless maintenance.  
**Durable:** Shot blasted, acid corrosion resistant.  
**Safe:** No sharp edges; 6mm heavy duty plate.  
**Adjustable:** Flexible height for secure locking.



妊娠母猪限位栏  
Gestation Crate



单体分娩栏  
One Beg - Farrowing Crate

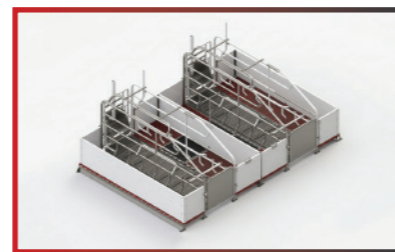

双体分娩栏  
Two Beg - Farrowing Crate

### 塑料漏粪地板 | Plastic Slatted Floor

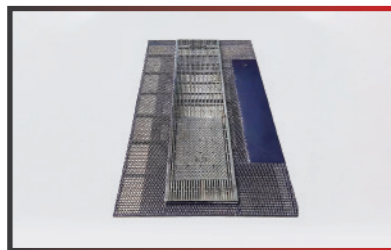

# RF刮板牵引式清粪机

## MANURE SCRAPER SYSTEM



固定式机头  
STATIONARY TYPE MOTOR



高强度刮粪板  
MANURE SCRAPER



转角轮  
PULLEY

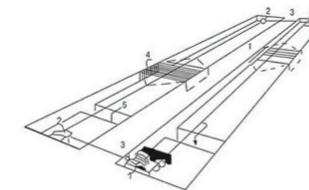

1、主机座 (绞盘)  
2、转角轮 3、牵引绳  
4、刮粪板 5、横向粪沟



全自动刮粪机控制箱  
CONTROL BOX

### 性能特点 | Features

**先进减速机:** 国标设计, 保证合理传动比。  
**结构紧凑:** 电机直连, 体积小且操作简便。  
**数控刮板:** 高精度成型, 坚固永不变形。  
**特殊链条:** 极强抗腐蚀与耐磨损性能。  
**超长寿命:** 加厚配件设计, 确保长期耐用。

**Advanced Reducer:** National standard for optimized transmission.  
**Compact Design:** Direct connection, easy to operate.  
**CNC Scraper:** Precise, no deformation.  
**Special Chains:** Anti corrosion & wear.  
**Durable:** Heavy - duty, long life.

### 操作应用 | Operation application

定期检查控制与安全系统。  
 每天至少清粪两次。  
 减速器每6个月润滑一次。  
 清除刮板残留以延长寿命。

Regularly check control and safety systems.  
 Clean up at least twice daily.  
 Lubricate reducer every 6 months.  
 Clean scraper to extend service life.



# RF系列家禽养殖料线

## POULTRY FEEDING LINE SYSTEM



### 自动喂料系统

#### Automatic feeding system

主进料系统由料塔、输送管、螺旋及传动装置组成。通过料位传感器自动控制电机启停，实现从料塔到料斗的高效自动化送料。

Automated silo to hopper feeding powered by smart sensors and a high efficiency motor.



#### 料盘 Feeder Pan

直径 Diameter: 33cm  
格栅 Grilles: 14  
饲养量 Quantity: 40 - 55



#### 驱动电机 Driving Motor

功率 Power: 0.75kw  
电压 Voltage: 380v  
频率 Frequency: 50hz, 3phase



#### 副料斗 Hopper

容积 Capacity: 115L  
材质: 热镀锌  
Material: Galvanized Steel



#### 料位传感器 Sensor

进口德国: 易福门  
Import from Germany: IFM



#### 送料系统 Delivery System

料管: 4孔/3米  
Feed Pipe: 4 holes/3m  
直径 Diameter: 45mm  
壁厚 Thickness: 1.2mm  
绞龙: 南非产  
Auger: From South Africa



#### 电动绞盘 Automatic Winch

功率 Power: 350W  
电压 Voltage: 3 phases - 380V, 50Hz  
电流 Electricity: 1.1A  
转速 Speed: 1390 rpm  
其他性能: IP 55, S1, F 级  
Other performance: IP 55, S1, F class

# RF系列家禽养殖水线

## POULTRY DRINKING LINE SYSTEM

乳头供水系统配有过滤器、调压器、加药器及防栖装置，满足各阶段禽类笼养或平养需求。采用UPVC全封闭管线，隔绝污染，防疫安全。多种型号可选。

Nipple system with filter, regulator, medicator, and anti roost. Supports all stage poultry (cage/floor). Closed UPVC pipes prevent pollution and disease. Multiple models available.

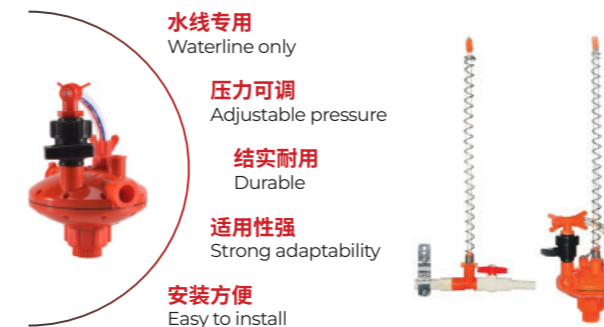
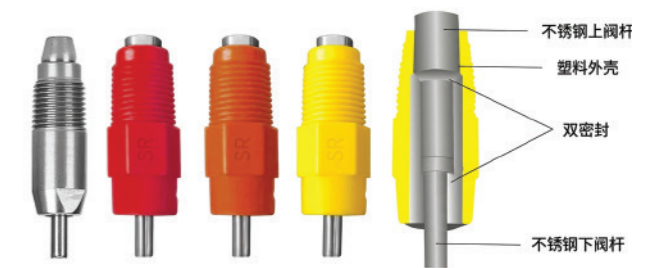

### 性能特点 | Performance features

自动饮水系统  
360°不锈钢/塑料乳头，出水量大  
食品级方管，安全卫生  
快速接头，防堵塞，安装快  
原材调压器，灵敏高 (单/双出)

Auto drinking system  
360° SS/plastic nipple, high flow  
Food grade pipe, safe environment  
Fast connector: anti clog, quick install  
High - sensitivity regulator (1/2 outlets)



# RF 设备与配件

## EQUIPMENT & ACCESSORIES

<b>料盘</b> Material tray 		
<b>16格内调双栖料盘</b> 16 grid inner tone amphibious tray 	<b>14格内调单栖肉鸡料盘</b> 14 compartmentsingle - dish broiler pan 	<b>鸭鹅专用料盘</b> Special tray for ducks and geese 
<b>15格内调单栖公鸡料盘</b> 15 compartment single - dish broiler pan 	<b>16格料盘</b> 16 grid tray 	<b>育雏专用料盘</b> Special feeding tray for brooding 
<b>普拉斯</b> Prazon 	<b>十四格料盘</b> 14 grid tray 	<b>鸡漏粪板</b> Open the food tray 

<b>锥阀饮水器</b> Cone valve water dispenser 	<b>六角不锈钢饮水器</b> Stainless steel water dispenser 		
<b>方管鸡用饮水器</b> Square tube chicken water dispenser 	<b>六分双乳头</b> Six point double nipple 		
<b>蛋鸡6分管球阀乳头</b> Egg chicken 6 tube ball valve nipple 	<b>方管鸡用饮水器</b> Square tube chicken water dispenser 	<b>圆管鸭用饮水器</b> Round tube duck water dispenser 	
<b>圆管一体吊杯</b> Round tube integrated hanging cup 	<b>方管一体吊杯</b> Square tube integrated hanging cup 	<b>圆管全包接水杯</b> Round tube fully wrapped water cup 	<b>方管双臂吊杯</b> Square tube double arm hanging cup 
<b>方管吊杯</b> Square tube hanging cup 	<b>鸭用一体吊杯(大)</b> Duck integrated hanging cup (large) 		

**方可调节水碗**

Square tube adjustabl water bowl



RF-34

**可调节育雏小碗**

Adjustable small bowl for brooding



RF-35

**水槽挂片**

Sink hanger



RF-36

**卡丝水碗**

Cassie water bowl



RF-37

**育雏小碗**

Chick raising bowl



RF-38



RF-39

**新型饮水碗**

New drinking bowl



RF-40

**喂食器**

Feeder



RF-41

**圆变圆S钩(ABS)**

Round to round S-hook (ABS)



RF-42

**圆抱卡**

Round hug card



RF-43

**方变圆抱卡**

Square to round holding card



RF-44

**调节板**

Adjusting plate



RF-45

**尼龙绳**

Nylon rope



RF-46

**不锈钢小白鼠饮水器**

Stainless steel mouse water dispenser



RF-47

RF-48

**十字饮水器**

Cross shaped water dispenser



RF-49

**兔用饮水器**

Rabbit water dispenser



RF-50

**鸽子饮水器**

Pigeon water dispenser

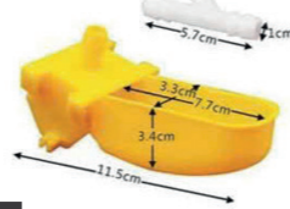

RF-51

**1500Lbs 绞盘**

1500Lbs Winch

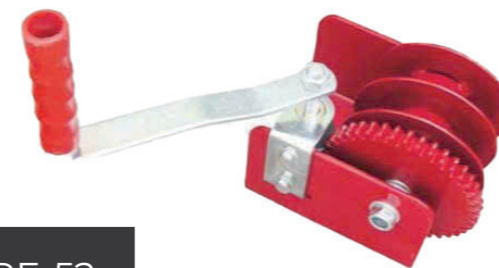

RF-52

**1500Lbs 绞盘**

1500Lbs Winch

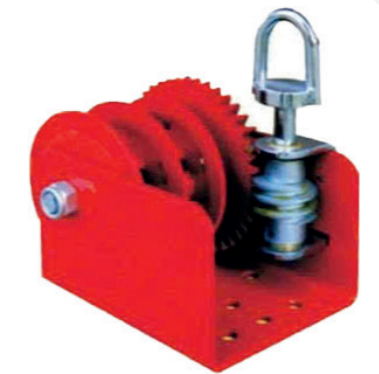

RF-53

**3500Lbs 绞盘**

3500Lbs Winch



RF-54

**3000Lbs 绞盘**

3000Lbs Winch

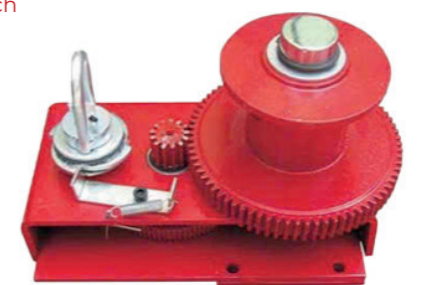

RF-55

**1200Lbs 一托三绞盘**

1200Lbs One-to-three winch

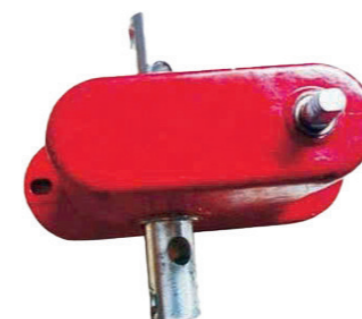

RF-56

**1500Lbs 热镀锌绞盘**

1500Lbs hot-dip galvanized winch

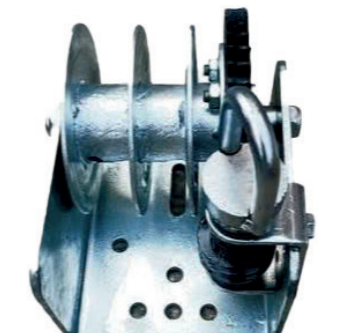

RF-57

**1200Lbs 镀铬绞盘**

1200Lbs chrome winch



RF-58

**1200Lbs 喷涂绞盘**

1200Lbs spray winch



RF-59

# RF种鸡链式供料系统

## POULTRY CHAIN FEEDING SYSTEM

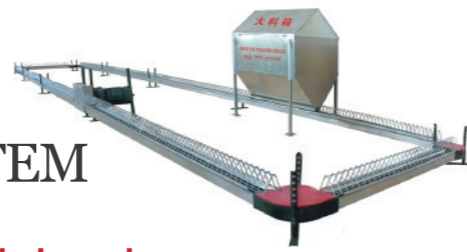

母鸡链式喂养系统 | Chain feeding system for female breeder

料线适应长度: 180 - 300 米  
料线适应长度: 小于 180 米  
电机功率: 2.2KW, 380V  
1.5KW, 380V

Length of feed line: 180 - 300m  
Length of feed line: <180m  
Electrical power: 2.2KW, 380V, 1.5KW, 380V

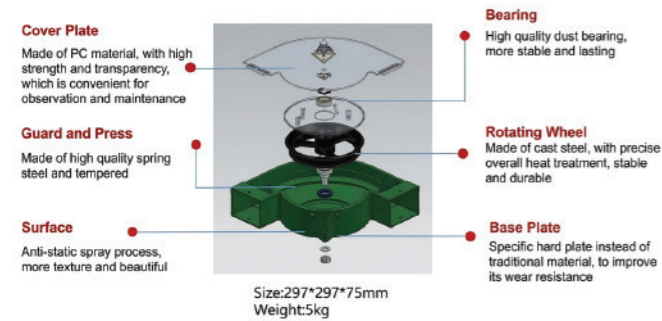

### 支架型链式喂料系统

Stent - chain feeding system

采用进口链条, 输送均匀快速。能力 0.7 - 1.5kg/m, 可随料箱调整。底部配有塑料支架。

Imported chain for fast, even delivery. Capacity: 0.7 - 1.5kg/m (adjustable). With bottom plastic stents.



### 90° 转角轮 牢固、耐用、免修理

90° durable corner wheel, non repair

含油粉末冶金轴套; 强化铸钢轮道; 外层防静电喷涂。南非原装进口。

Oil free powder metal bushing; Reinforced steel track; Anti static coating. Made in South Africa.

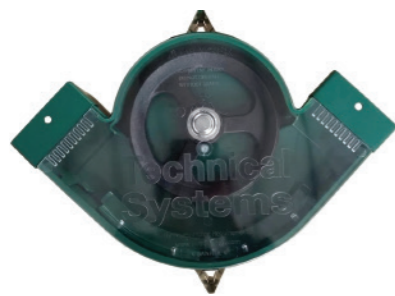

### 驱动装置

Driving Device

链速 36m/min。稳固底座确保运行。设安全销。24h 自动定时。手/自双模, 电箱控制。

Chain speed: 36m/min. Solid base for stable ops. Safety pin included. 24h auto timer. Manual/Auto control box.



# RF控制系统

## CONTROL SYSTEM

畜禽舍控制系统 | Poultry house control system features

触屏操控: 7"/10" 触摸屏, 多语言菜单。  
自动报警: 超温、低温及电源异常报警。  
智能控制: 自动调节加热 (6组)、小窗、雾线及进料。  
模拟环境: 自动模拟日出日落, 感应季节切换模式。  
高效通风: 支持24组定速及2组调速风机。  
远程管理: 具备电脑通信接口, 支持曲线自动调控。

Control: 7"/10" Multi - language Touchscreen.  
Alarms: Auto - alerts.  
Automation: Heating, Inlets & Feeding.  
Environment: Sunrise/Sunset, Seasonal modes.  
Ventilation: Up to 26 Fans.  
Remote: PC interface with auto curve regulation.

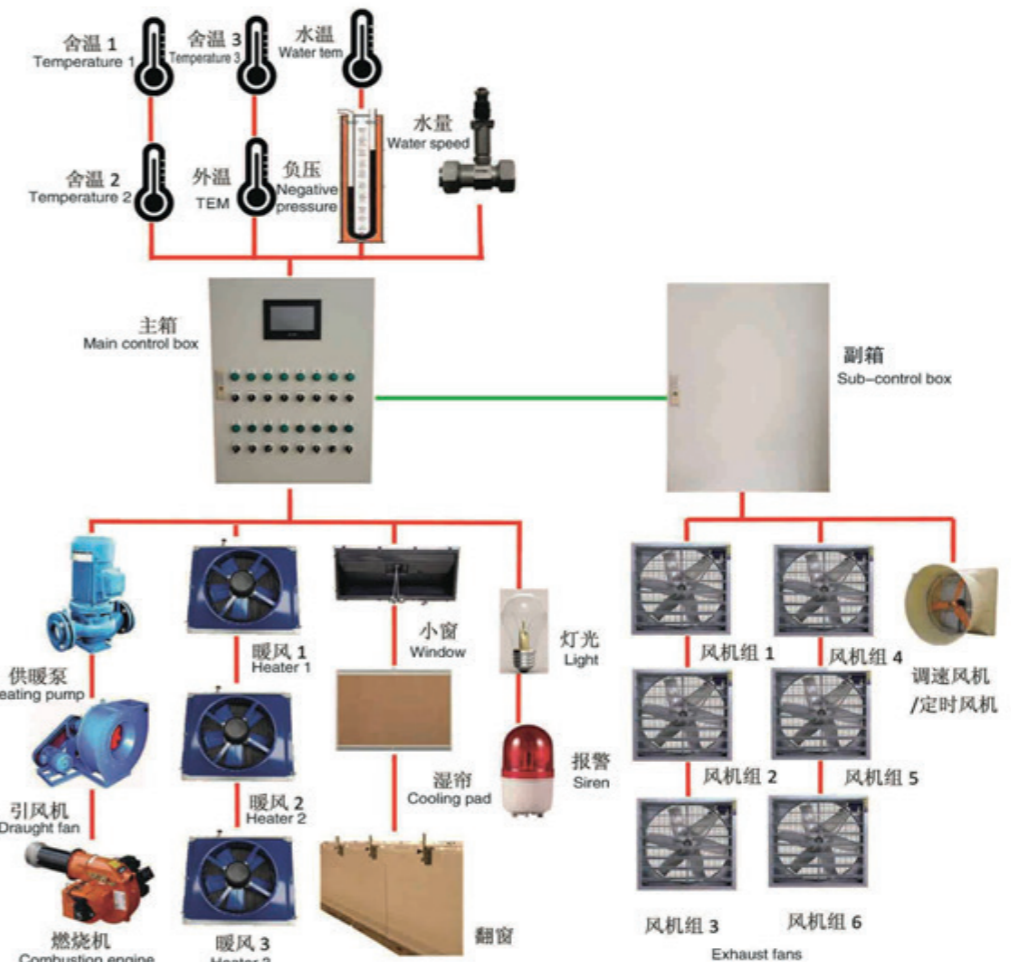

### 猪舍控制系统 | Pig house control box

内置生长周期通风参数。一键设定, 全自动控制通风、加温及降温设备, 操作简便可靠。

Pre set growth stage parameters. Fully automates ventilation, heating, and cooling. Simple and reliable operation.

# RF 集约化农场解决方案

## INTENSIVE FARM SOLUTIONS



### 一站式交钥匙工程解决方案 | Turnkey Total Solutions

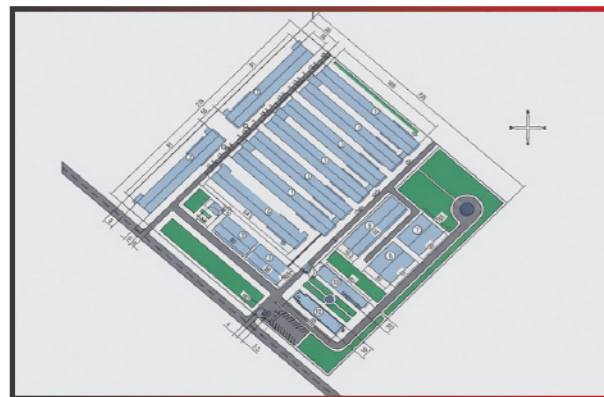

**项目整体规划:** 提供场地定制化项目规划及3D布局设计。  
**鸡舍布局设计:** 专业设备布局, 确保最佳通风效果与养殖效率。

**Overall project plan:** Custom project planning and 3D farm layout design.  
**Chicken House Layout:** Equipment layout design for optimal ventilation and farming efficiency.

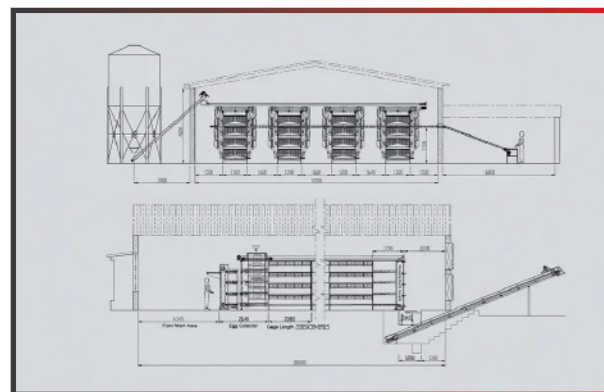

**项目工程图纸:** 提供详尽工程图纸, 协助施工顺利进行。

**Project Drawings:** Detailed technical drawings for construction support.



**交钥匙工程服务:** 从咨询、生产、安装到运维的一站式交钥匙服务。

**Turnkey Service:** One - stop solution from consultation, production, installation, to maintenance.

提供全套集约化养禽解决方案, 助您打造现代化高效养殖场。

### Moder Poultry Farming Solutions



**定制化农场配套设备:** 根据您的农场实际情况, 我们提供从孵化场、屠宰场到物流及办公设施等全方位解决方案, 助力平稳运营, 实现收益最大化。

**Farm supporting equipment:** We analyze your site to provide tailored solutions from hatcheries and slaughterhouses to logistics and facilities ensuring smooth operations and maximum profitability.



**农场人员配置:** 根据养殖场规模, 我们为您制定科学的定员定岗方案, 确保运营流程更顺畅、更高效。

**Farm staffing:** According to the scale of the farm, we will design a staffing table for you to ensure a smoother operation of the farm.



**项目施工方案:** 我们为您设计合理的项目施工计划, 优化资金回笼周期, 助力项目快速收回成本。

**Project construction plan:** We will design a reasonable project plan for you and potentially help you withdraw funds faster.

# RF H型养殖解决方案

## H - TYPE LAYER CAGES SOLUTIONS

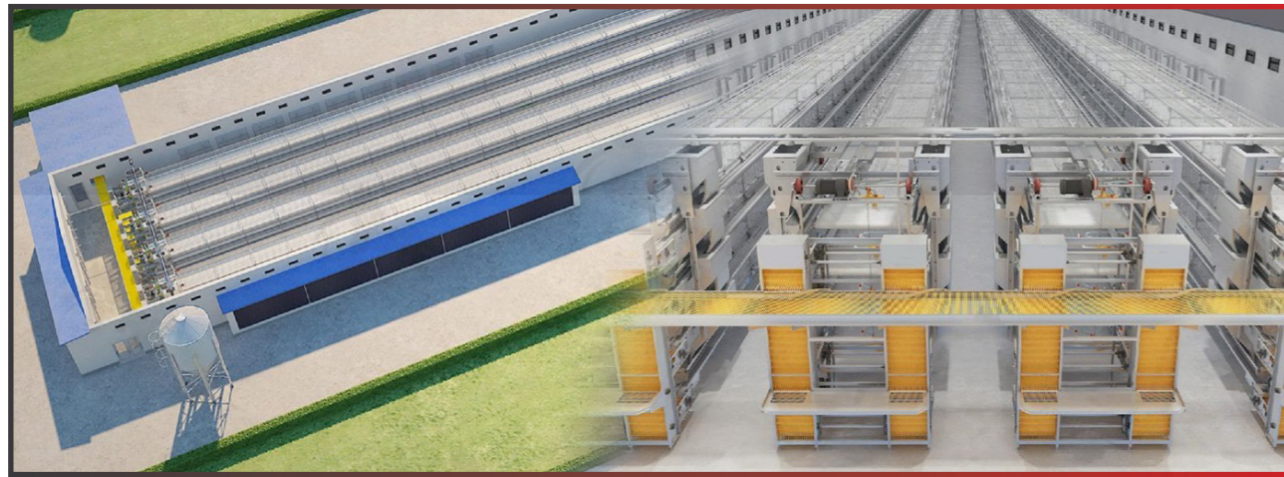

### 一站式交钥匙工程解决方案 | Smart Farming Solutions

**环境更优, 产能更高:** H型蛋鸡养殖设备使用寿命长达20年, 养殖密度大, 生产效益高。全面满足您在禽类健康、产蛋性能及环境控制方面的最高标准。

**Superior Performance & Longevity:** Our 20 years H - type layer systems maximize capacity and productivity while ensuring optimal bird health and environmental control.

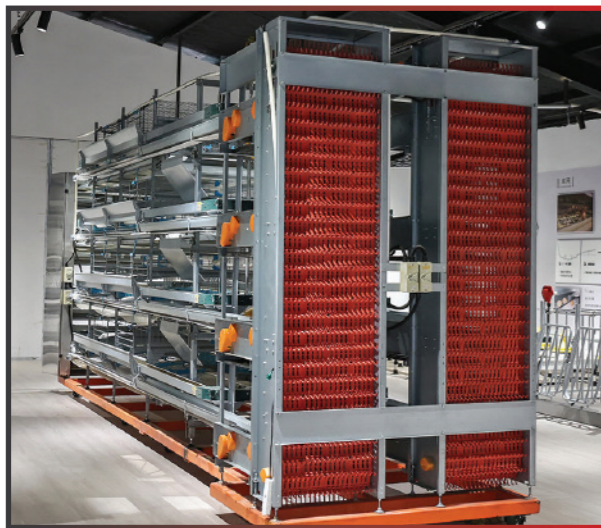

**智能集约化管理:** H型蛋鸡设备配备全自动配套系统, 旨在提升养殖效率、降低运营成本, 让养殖管理更轻松、更智能

**Intensive Automation:** Our H - type systems feature fully automated controls to maximize efficiency, minimize costs, and simplify daily farm management.



**最优生产性能:** 理想的养殖环境可确保禽群舒适度, 从而实现更高的养殖效率。

**The optimal production performance:** The ideal raising environment makes the birds more comfortable and the raising efficiency is higher.

# RF A型养殖解决方案

## A - TYPE LAYER CAGES SOLUTIONS

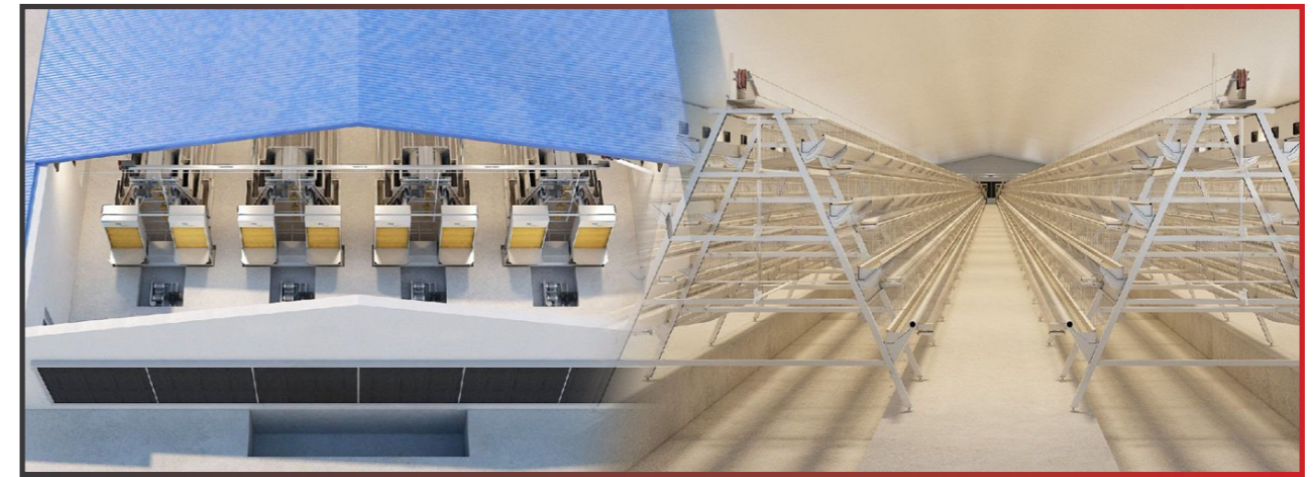

### 一站式交钥匙工程解决方案 | Smart Farming Solutions

**轻松开启现代化养殖:** A型设计, 20年超长寿命; 优越的自然通风, 热带气候的首选。

**Easy to start modern farm:** A - type design with 20 years lifespan; ideal natural ventilation for tropical climates.



**灵活自动化升级:** 按需选配自动系统, 低能耗, 助力农场轻松升级。

**Flexible Automation:** Optional automated systems; energy efficient and perfect for scaling up.



**最优生产性能:** 理想的养殖环境可确保禽群舒适度, 从而实现更高的养殖效率。

**Versatile:** Compatible with all house types: open, semi open, and closed.

# RF 畜牧业解决方案

## BROILER FARM SOLUTIONS

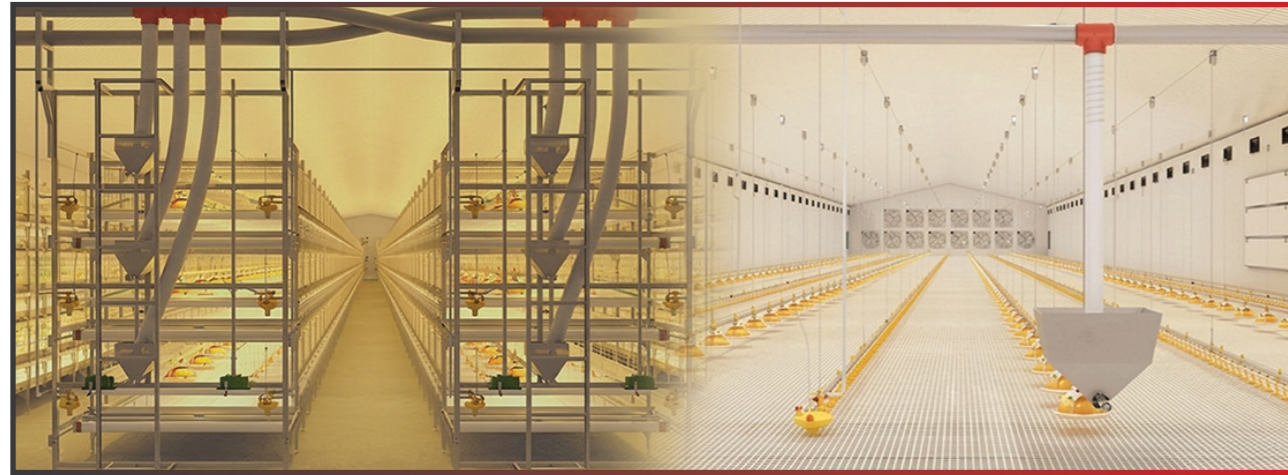

### 一站式交钥匙工程解决方案 | Turnkey Total Solutions

**高效高密度养殖:** 显著提高土地利用率, 降低能耗, 便于禽群监测。20年使用寿命, 大型肉鸡养殖的首选。

**High - Density Efficiency:** Maximizes space, reduces energy costs, and simplifies flock monitoring. 20 years lifespan; ideal for large - scale operations.

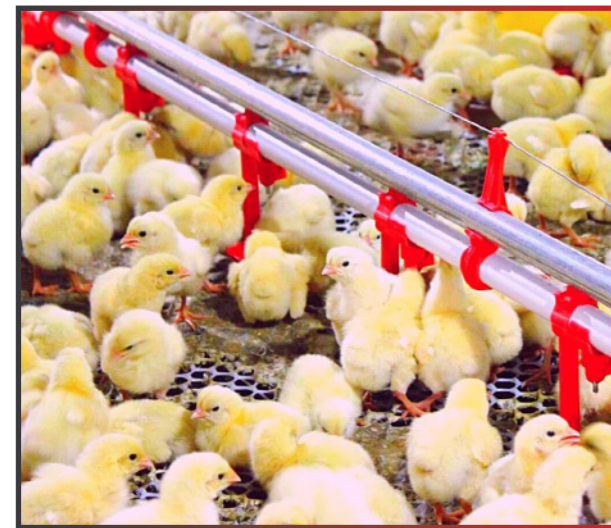

**卓越料肉比 (1.4:1):** 营造舒适环境, 提高存活率; 实现精准喂养, 大幅提升饲料转化率。

**Superior FCR (1.4:1):** Optimized environment boosts comfort and survival rates; ensures precise feeding and high feed conversion efficiency.



**省时省力:** 实现喂料、饮水、清粪、出栏及环境控制全自动化, 大幅降低人工成本。

**Labor & Time Savings:** Fully automated systems for feeding, drinking, manure removal, and harvesting; drastically reduces manual labor.

# RF 育成及种鸡方案

## PULLET & BREEDER FARM SOLUTIONS



### 一站式交钥匙工程解决方案 | Turnkey Total Solutions

**高效性:** 最大化土地利用率, 设施耐用且使用寿命长。

**自动化:** 实现喂料、环境控制及粪便管理的全面自动化。

**High Efficiency:** Maximized land use with durable, long - term infrastructure.

**Automation:** Fully automated systems for feeding, climate control, and waste systems.



**经济型结构:** 砖混墙体结合钢结构屋顶, 兼顾经济性与耐用性。

**Health & Performance:** Streamlined operations significantly reduces manual labor demands.



**智能环境控制:** 自动调节气候参数, 确保最优环境, 极大降低人工操作负担。

**Labor Savings:** Controlled environments guarantee uniform growth, high viability, and reproductive success