



Link to  
assembly videos

# CELESTA Multi-Track Patio Door S-8375 [OXXXXO]

REVISION:  
2020/05/28

*On site Assembly Instructions*

9950.00.GI.8375.6V.A

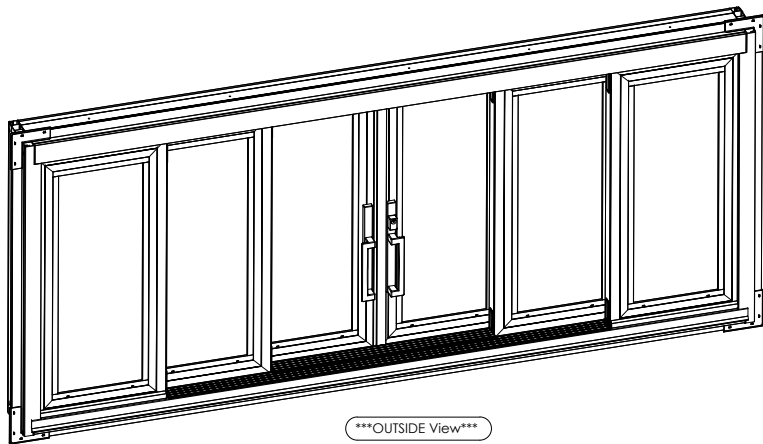

\*\*\*OUTSIDE View\*\*\*

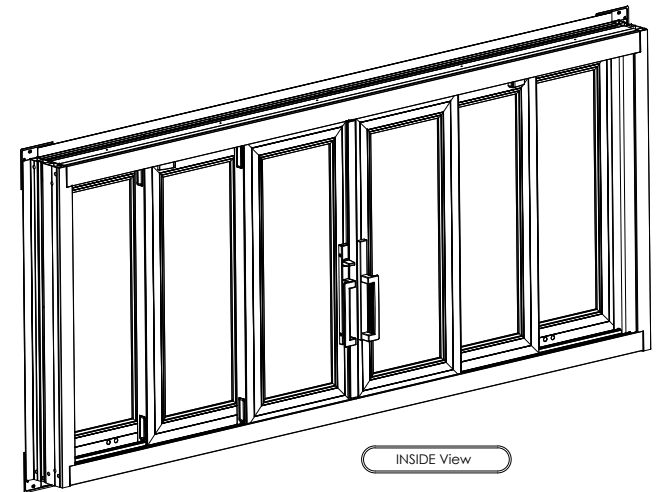

INSIDE View

CONFIDENTIAL

The contents of this document and all revisions thereof are confidential and subject to the world-wide copyrights of P.H.-Tech Inc. Any use, reproduction or disclosure thereof without the written permission of P.H.-Tech Inc. is prohibited.

Specific details of all the intellectual property rights relating to this document and the systems and components shown are available from P.H.-Tech Inc., Levis, Quebec  
Canada G6V 9G9.





# Table of Contents

## Installation Requirements

- List of required Tools ..... P1
- Box (HEAD / SILL / JAMBS / SASHES / SCREEN (Option) / HARDWARE) ..... P2

## ✓ STEPS to Follow:

*MATERIAL*	<input type="checkbox"/>	<b>1</b>	- Validation of the Hardware ..... P3-P4
	<input type="checkbox"/>	<b>2</b>	- Validation of HEAD Box & Preparation ..... P5 to P8
	<input type="checkbox"/>	<b>3</b>	- Validation of SILL Box & Préparation ..... P9-P10
	<input type="checkbox"/>	<b>4</b>	- Validation of JAMBS Box ..... P11
*FRAME*	<input type="checkbox"/>	<b>5</b>	- Frame Assembly ..... P12 to P14
	<input type="checkbox"/>	<b>6</b>	- Installation of the Frame ..... P15 to P20
*SASH*	<input type="checkbox"/>	<b>7</b>	- Installation of Fixed Sashes ..... P21 to P25
	<input type="checkbox"/>	<b>8</b>	- Installation of Centrals Sashes & Head Tracks #8321 ..... P26 to P29
	<input type="checkbox"/>	<b>9</b>	- Installation of Mobiles Sashes & Head Tracks #8321 ..... P30 to P32
	<input type="checkbox"/>	<b>10</b>	- Adjustment of Sashes ..... P33
*HEAD*	<input type="checkbox"/>	<b>11</b>	- Installation of Head Blocks ..... P34 to P37
	<input type="checkbox"/>	<b>12</b>	- Installation of Jamb Covers (Interior) & Sash Stops ..... P38-P39
	<input type="checkbox"/>	<b>13</b>	- Installation of Head Covers #8323 ..... P40 to P42
	<input type="checkbox"/>	<b>14</b>	- Fastening Head Tracks #8321 to the Frame ..... P43-P44
	<input type="checkbox"/>	<b>15</b>	- Installation of Groove Covers #8331 ..... P45 to P47
*FINISHING*	<input type="checkbox"/>	<b>16</b>	- Installation of Astragal ..... P48-P49
	<input type="checkbox"/>	<b>17</b>	- Installation of Handles, Lock & Keeper ..... P50 to P52
	<input type="checkbox"/>	<b>18</b>	- Installation of Drip Caps ..... P53 to P55
	<input type="checkbox"/>	<b>19</b>	- Installation of Sills Covers ..... P56 to P58
	<input type="checkbox"/>	<b>20</b>	- Final Ajustement ..... P59
	<input type="checkbox"/>	<b>21</b>	- **OPTION** - Preparation for Retractable Screen Installation..... P60 to P62



List of required Tools

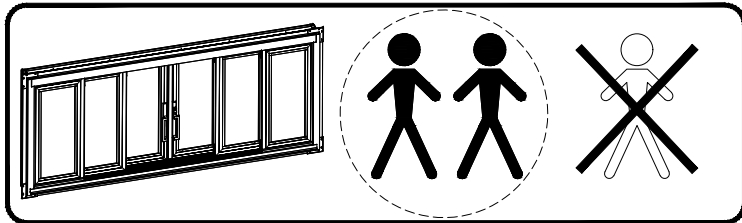

\*Assembly required by 2 people\*

**IMPORTANT**



Impact  
(1X)

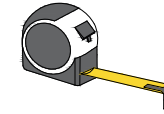

Measuring Tape  
(1X)

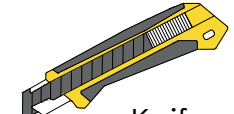

Knife  
(1X)



Screwdriver Bit  
Quadrex 6" #2 (1X)

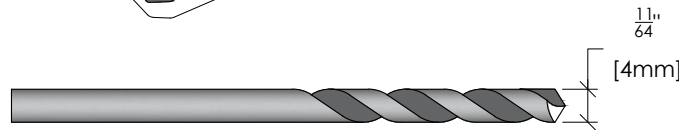

Drill Bit  
(min.1X)



Pencil  
(1X)

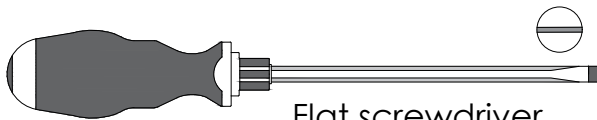

Flat screwdriver  
(1X)



Countersink  
(for #8 screw)  
(min.1X)

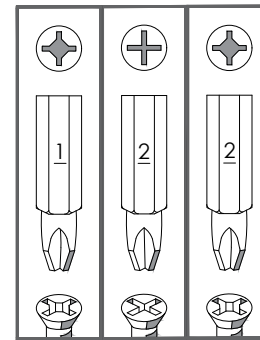

Screwdriver Bits  
(3X)



Rubber Mallet  
(1X)

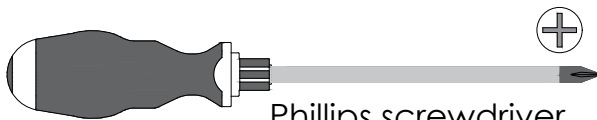

Phillips screwdriver  
(1X)



Invisible Lubricant  
Silicone  
(1X)

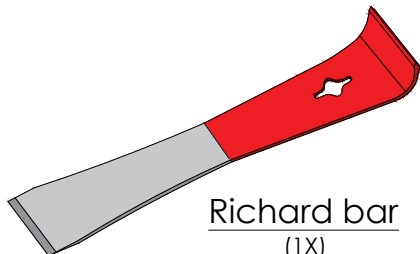

Richard bar  
(1X)

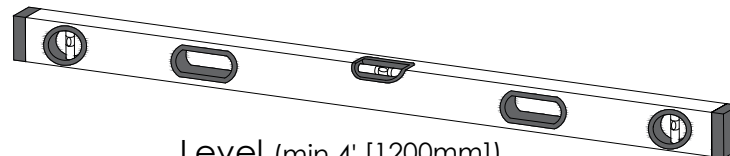

Level (min 4' [1200mm])  
(1X)

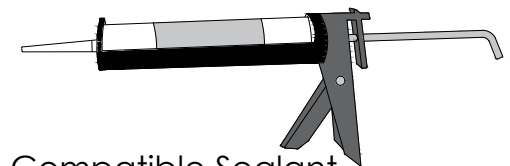

Compatible Sealant  
(min.1X)



STEP:  
**0**

# List of Packaging Boxes

REVISION:  
2020/05/28

PAGE:  
P2

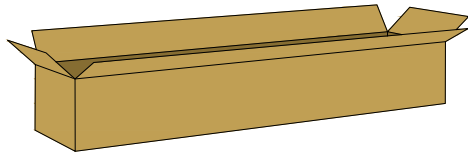

Jambs box  
(1X)

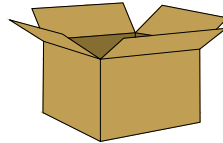

Hardware Box  
(1X)

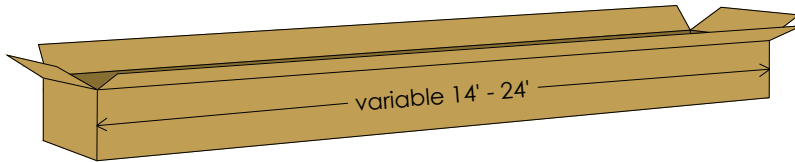

Head Box  
(1X)

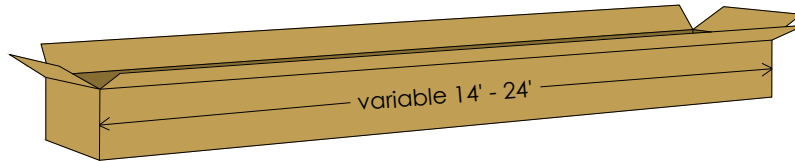

Sill Box  
(1X)

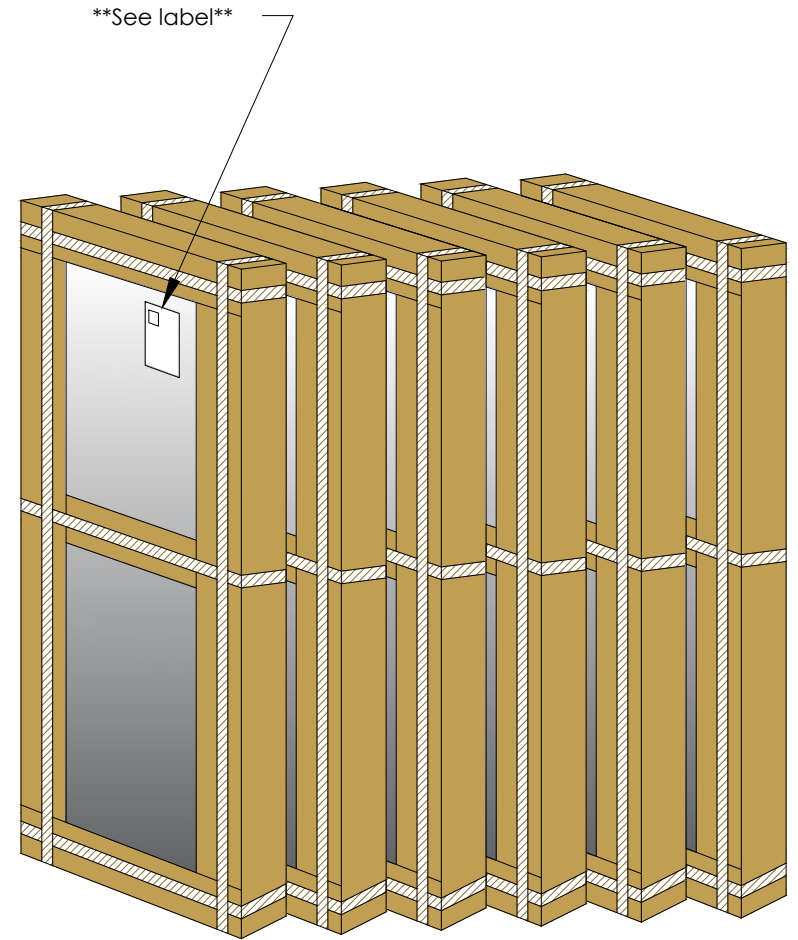
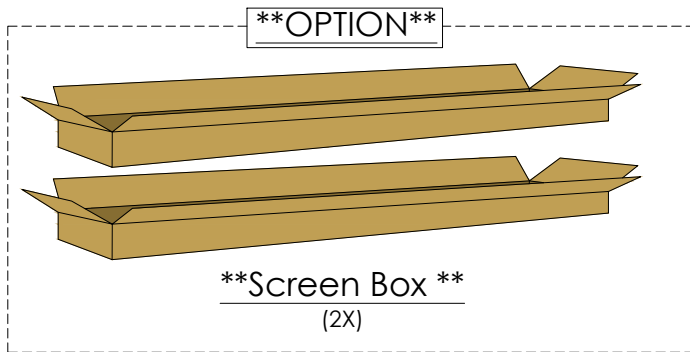

Sashes Boxes  
(6X)



STEP:  
**1**

Validation of the Hardware

REVISION:  
2020/05/28

PAGE:  
P3

**08375.58.SACn1.6V : FRAME & SASH Hardware bag**

**9619.VIS08 (12X)**  
**8942.VIS10 (24X)**  
**8941.VIS08 (4X) \*BLACK\***  
**9876.VIS08 (8X)**  
**8784 (2X)**  
**9667.CAPUC (8X)**  
**9853 (10X)**  
**8397.58.ANCVS (1X)**  
**8389.CAPEV (2X)**  
**8770.LAMCO (4X) (OPTION)**  
 -(If with nailing fine)  
**8389.ARREV (2X)**

---

**09750.00.INST.6VMP : Installation bag**

**9683.VIS10 (18X)**  
**9759.VIS08 (24X)**  
**9825.VIS10 (48X)**  
**9859 (24X)**

**IMPORTANT: Hardwares are provided for Installation in Wood box.**

**\*A\***

**For concrete application: screws are NOT provided.**

**\*If painted door (OUT= Outside) or (IN=Inside), rather use parts on red bag in Sill box &/or Sash box.\***



STEP:  
**1**

(Continued) Validation of the Hardware

REVISION:  
2020/05/28

PAGE:  
P4

**08380.00.SACn2.6V** : HEAD Hardware bag

**8942.VIS10** (32X)

**8941.VIS08** (18X) **\*BLACK\***

**8940** (2X) **\*\*Assembled with shim 8789\*\***

**8703.BMSCF** (2X)

**00703.ADM35** (5X)

**\*\*Assembled with foam 8373\*\***

**08375.58.SACn3.6V** : FINISHED Hardware bag

**8813.VIS10** (8X)

**9150.CAPUC** (2X)

**8395.58.CAPVS.G** (1X)

**8395.58.CAPVS.D** (1X)

**8377.GAPSF** (1X) **Adhesive backside**

**(OUT)**

**08375.58.SAAST.6V** : Astragal Installation bag

**8772.VIS08** (6X)

**9667** (8X) **(IN)**

**8941.VIS08** (2X) **\*BLACK\***

**9135** (2X)

**9873** (2X)

**09250.KT.ENS2P** : Lock & Keeper bag

**9250.SER2P** (1X)

**9250.GACHE** (1X)

**Screw #10 x 2-1/2"** (2X)

**\* Not required \*** **9149.VISME (#10 x 3/4")** (2X)

**9250.VISGA (#10 x 1-3/4")** (4X)



# Validation of HEAD Box & Preparation

\*Materiels and hardware .....

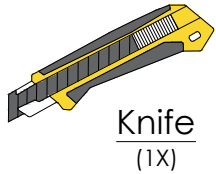

Knife  
(1X)

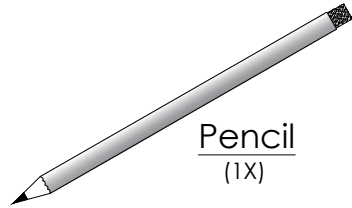

Pencil  
(1X)

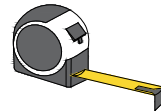

Measuring Tape  
(1X)

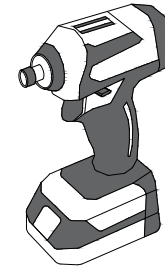

Impact  
(1X)

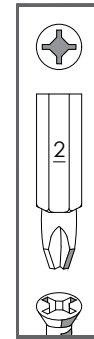

Screwdriver Bit  
(1X)



08380.58.SACn1.6V : FRAME & SASH Hardware bag

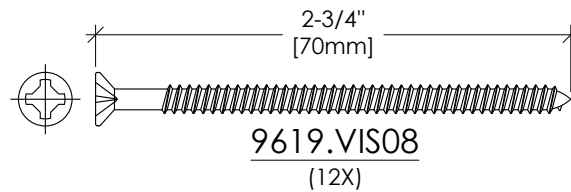

Countersink  
(for #8 screw)  
(min.1X)





STEP:  
**2**

(Continued) Validation of HEAD Box & Preparation

REVISION:  
2020/05/28

PAGE:  
P6

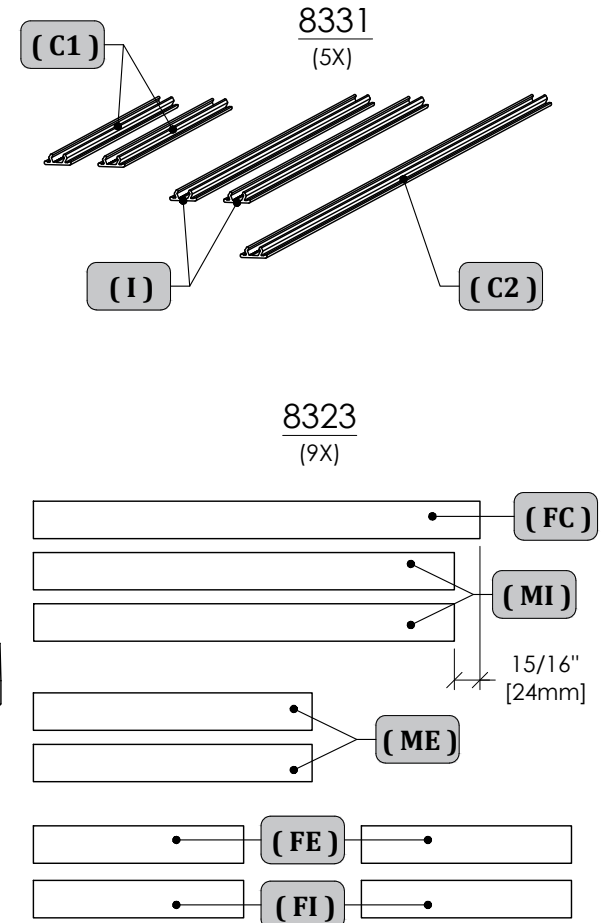
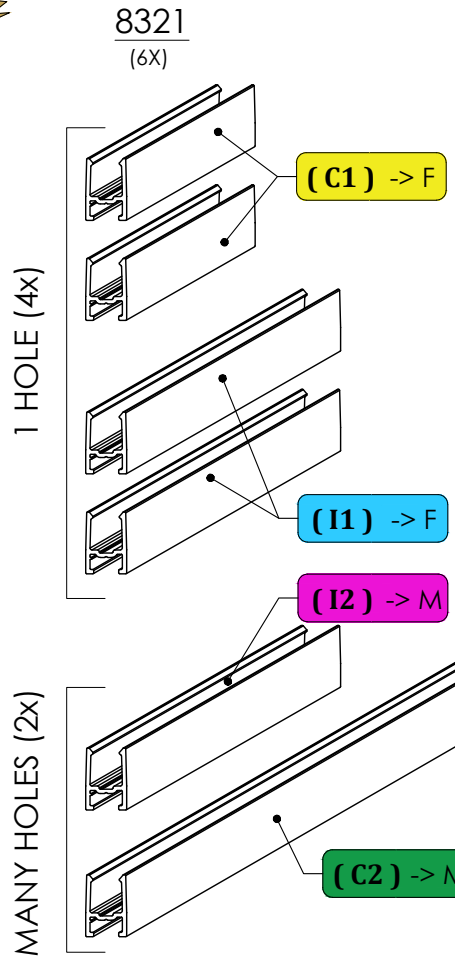
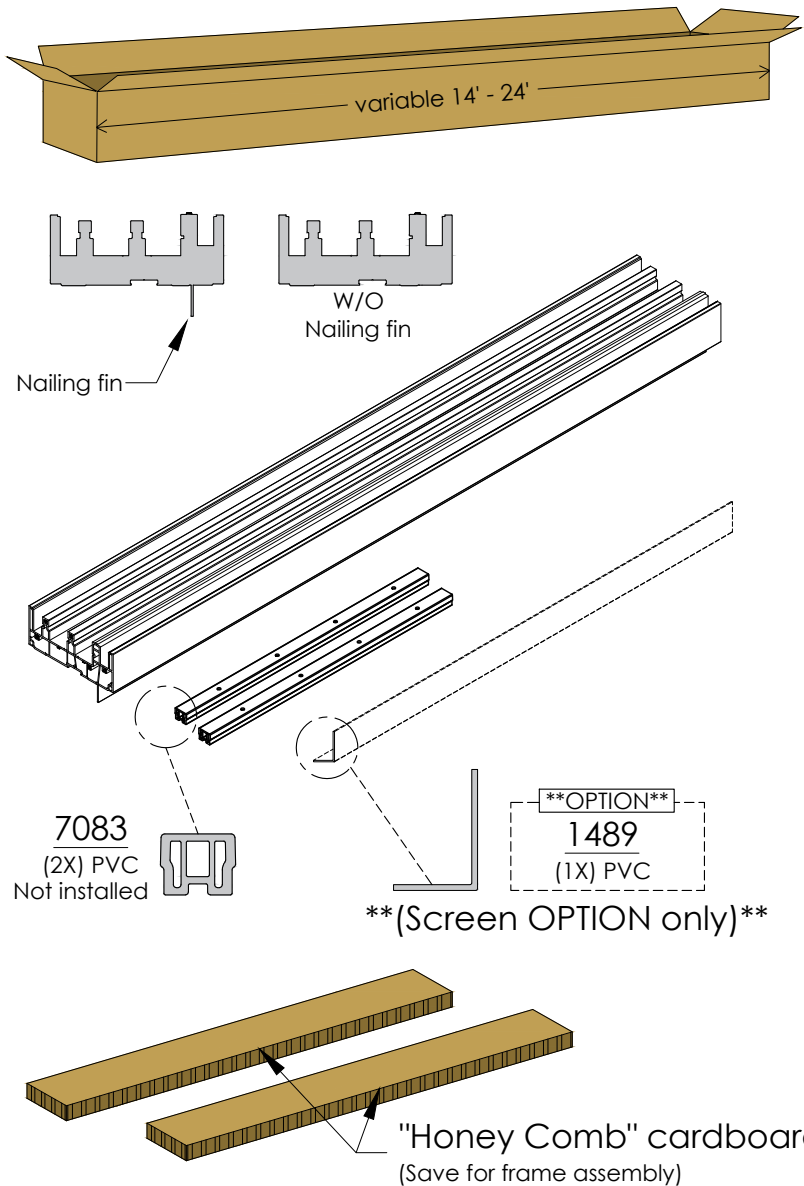

**\*A\*** Save into the Head box for further installation. (See Step 8 to 15)

**\*\*If Screen OPTION\*\* : Save also component 1489 for further installation. (See Step 21)**



(Continued) Validation of HEAD Box & Preparation

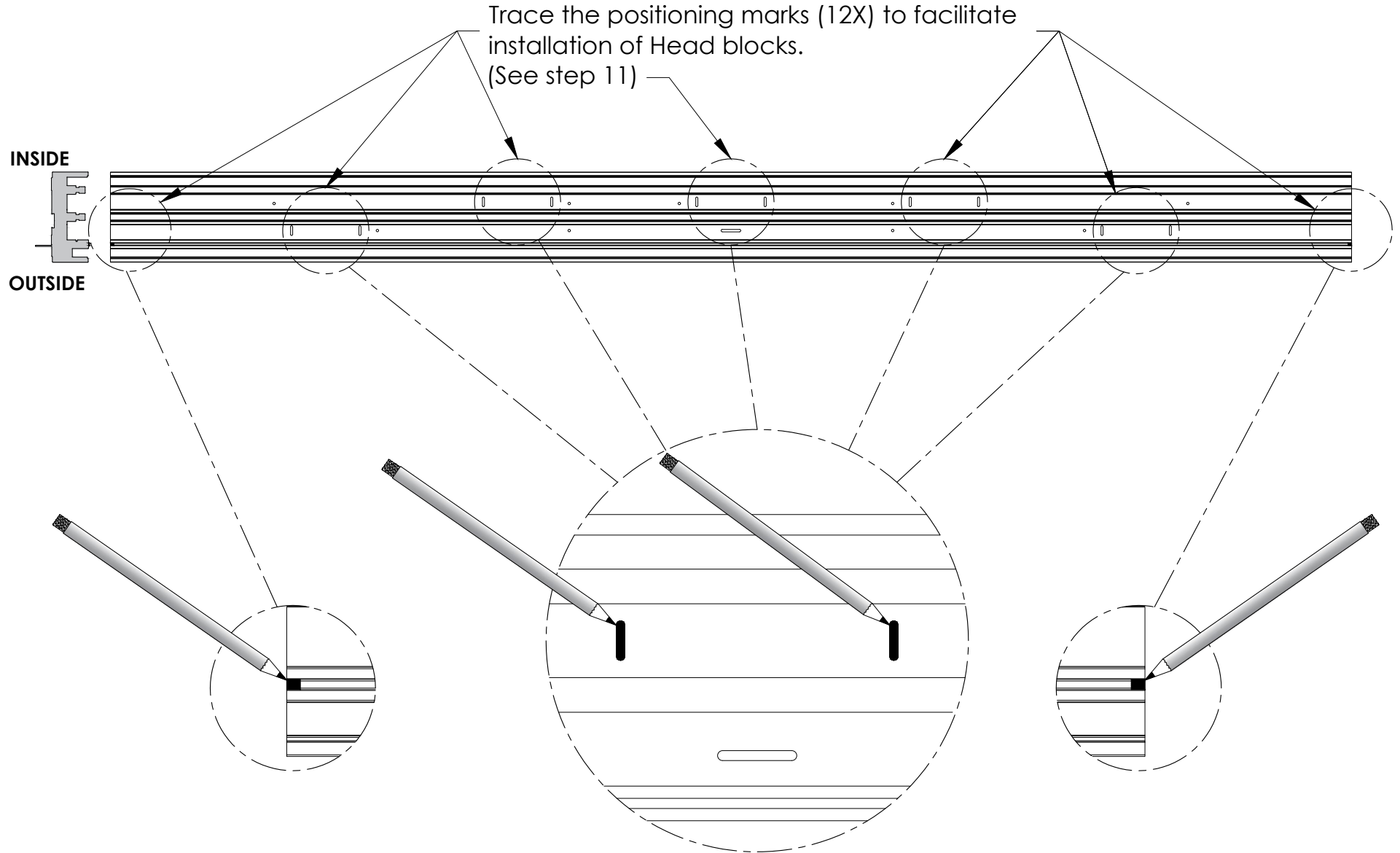



STEP:  
**2**

(Continued) Validation of HEAD Box & Preparation

REVISION:  
2020/05/28

PAGE:  
P8

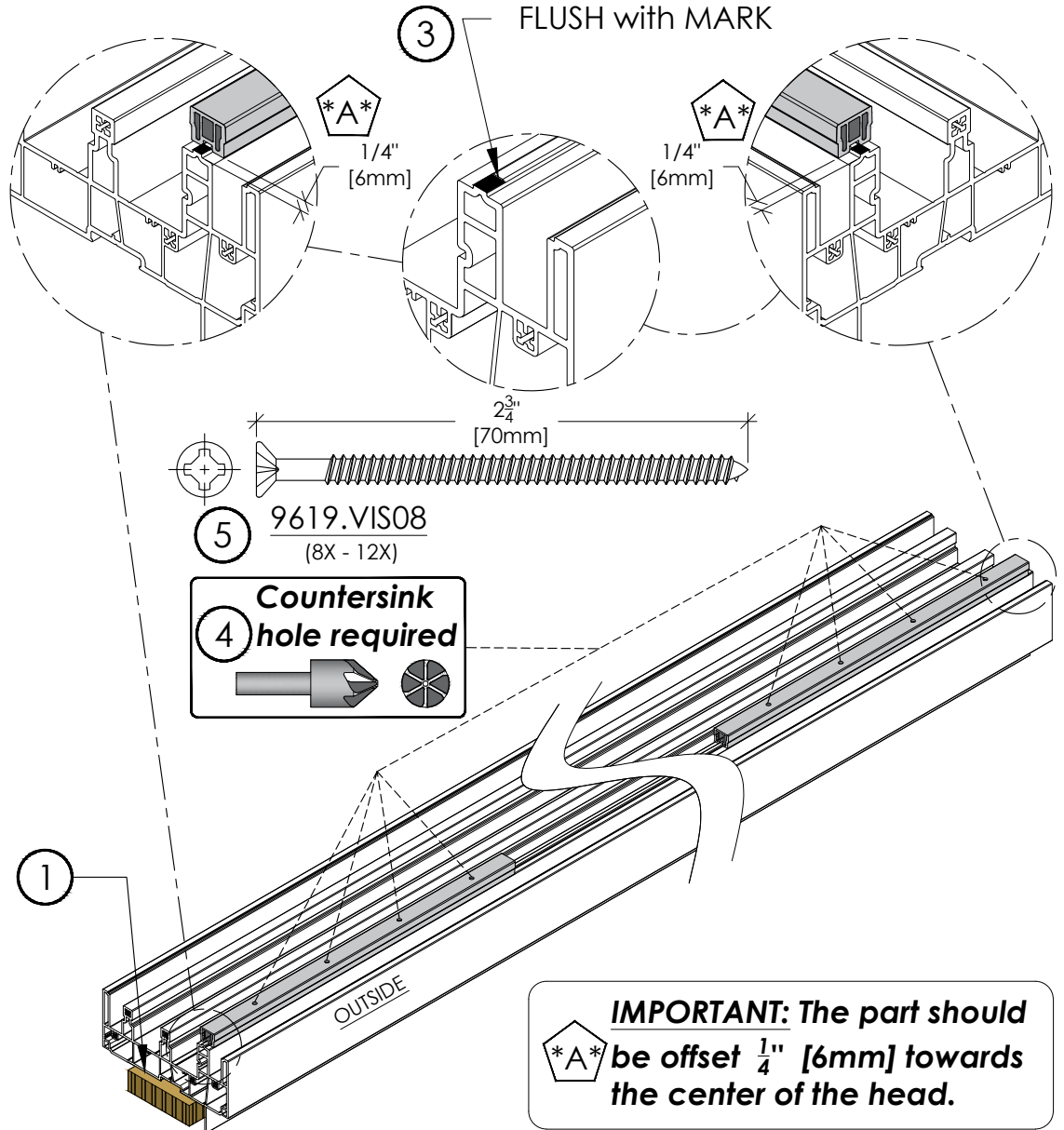
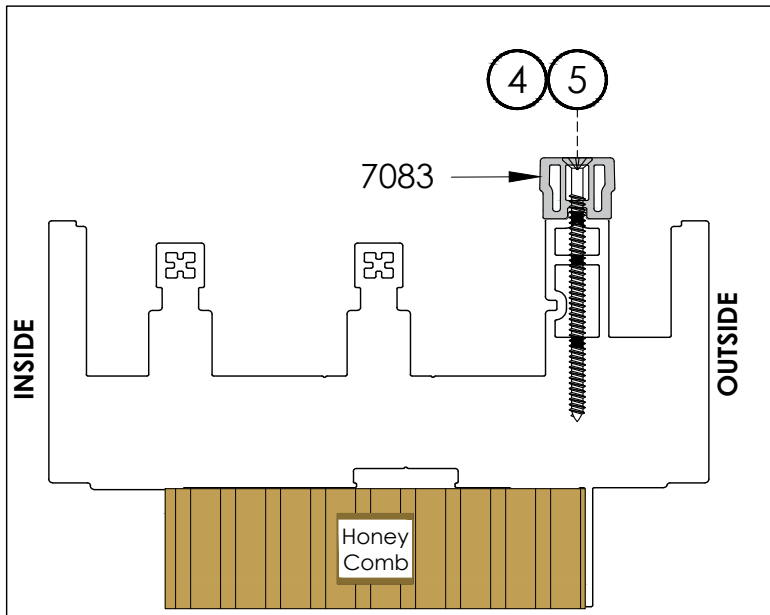
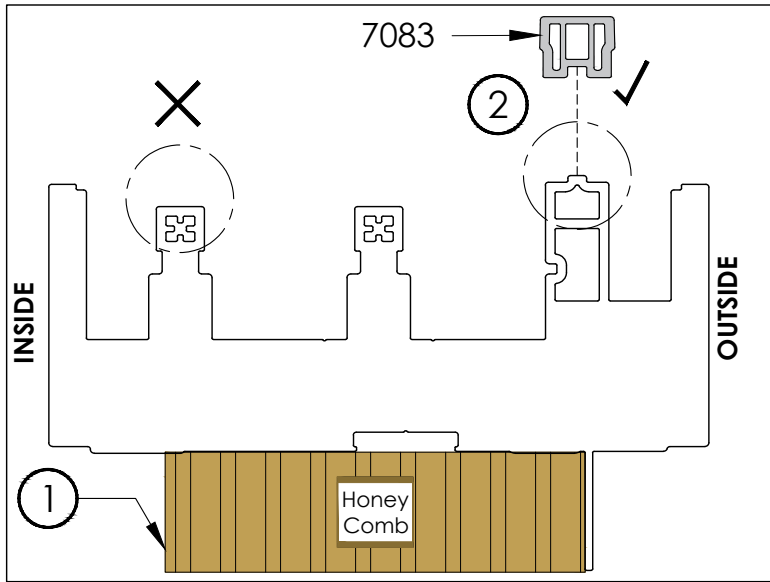

**IMPORTANT:** The part should be offset  $\frac{1}{4}$ " [6mm] towards the center of the head.



STEP:  
**3**

Validation of SILL Box & Preparation

REVISION:  
2020/05/28

PAGE:  
P9

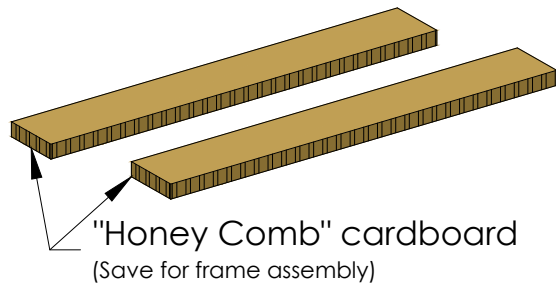
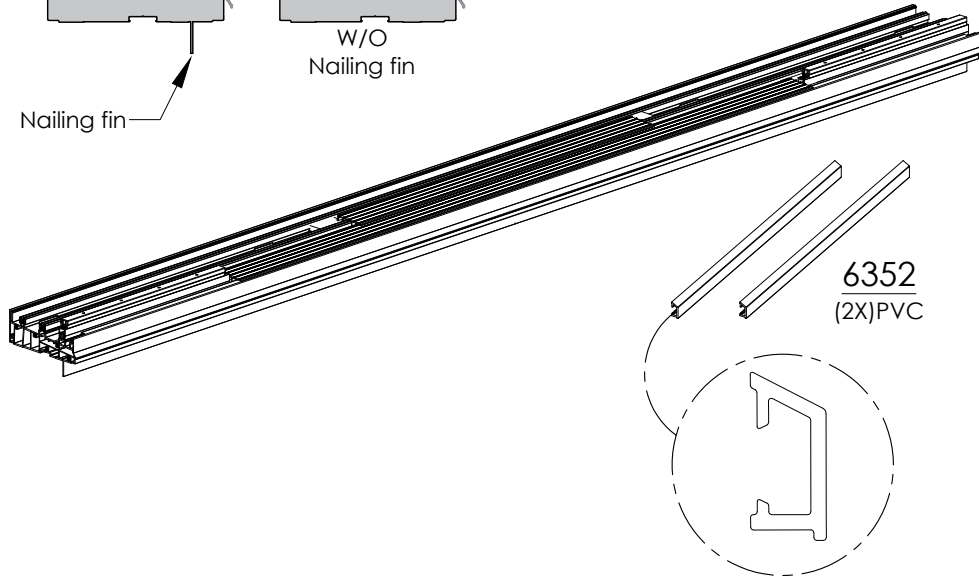
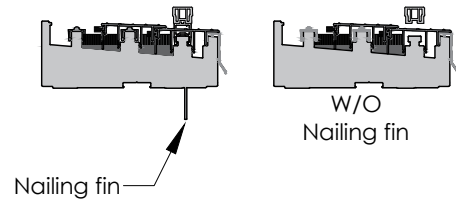
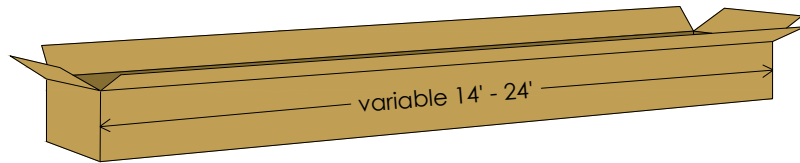

\*OPTION if painted door:  
The red bag contains the  
painted hardware.

Only if astragal is painted (OUTSIDE & INSIDE)			<b>9667.CAPUC</b> (8X)	
INSIDE PAINT		<b>9667.CAPUC</b> (8X)		<b>8389.CAPEV</b> (2X)
OUTSIDE PAINT		<b>8395.58 CAPVS.G</b> (1X)		<b>8395.58. CAPVS.D</b> (1X)

- Save components **6352** into the **HEAD** box for further installation. (See Step 18)
- If door is painted: save also the red bag.



STEP:  
**3**

(Continued) Validation of SILL Box & Preparation

REVISION:  
2020/05/28

PAGE:  
P10

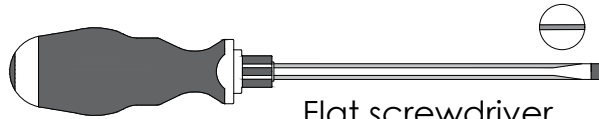

Flat screwdriver  
(1X)

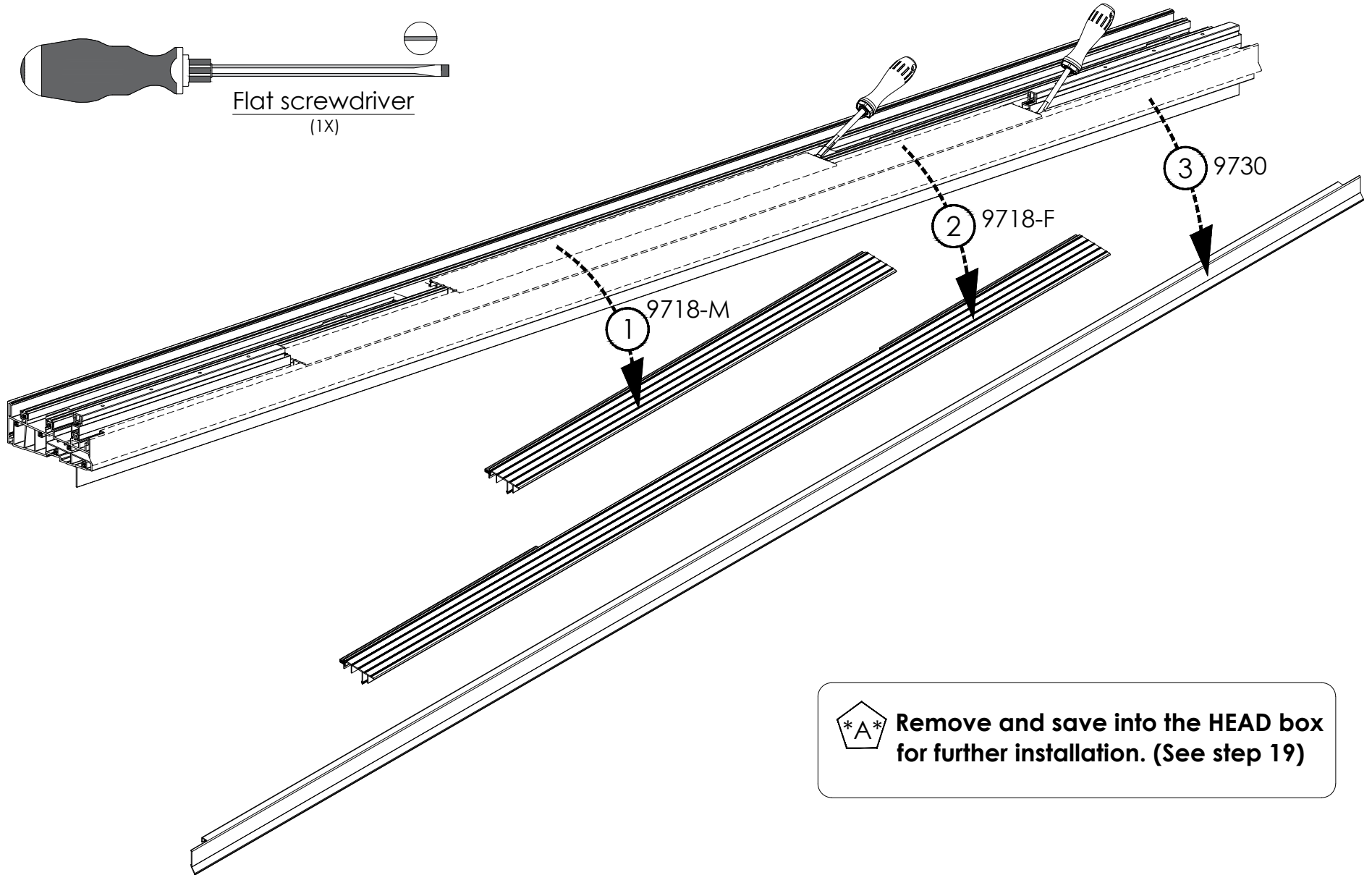

**\*A\*** Remove and save into the HEAD box for further installation. (See step 19)



STEP: **4**

# Validation of JAMBS Box

REVISION: 2020/05/28

PAGE: P11

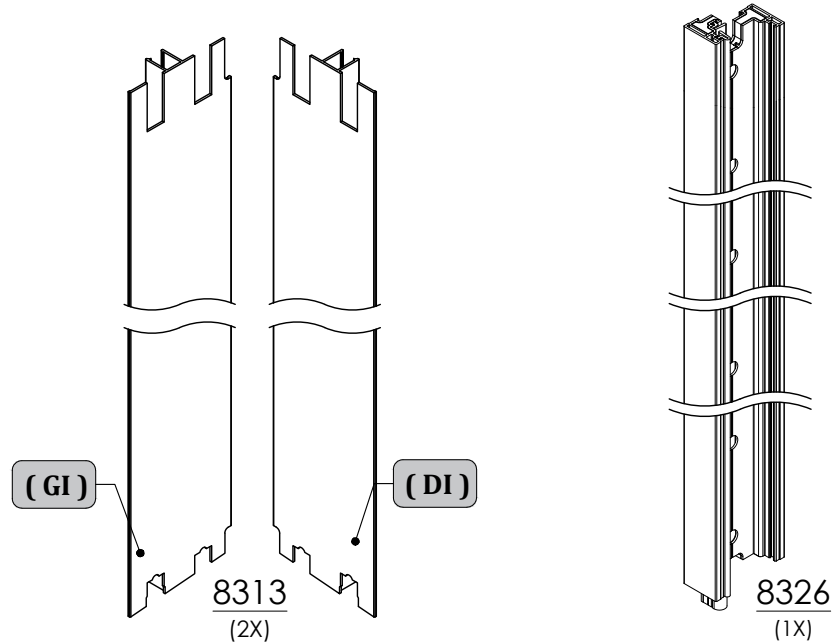
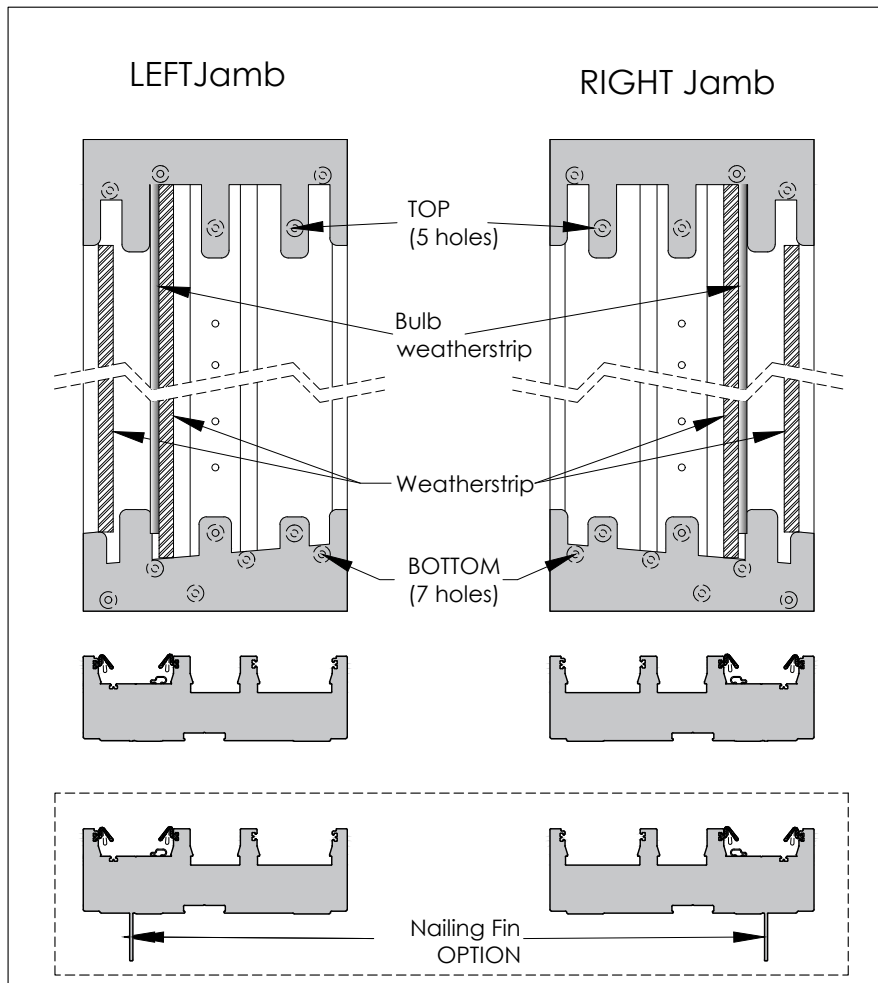
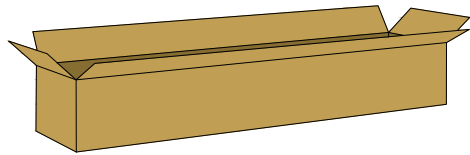

**\*A\*** Save components 8313 & 8326 into the HEAD box for further installation. (See Step 12 & 16)

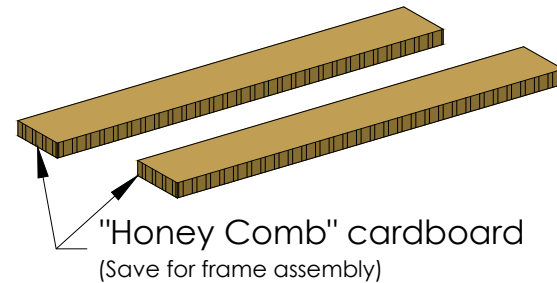



STEP:  
**5**

Frame Assembly

REVISION:  
2020/05/28

PAGE:  
P12

\*Tools and hardware required for this step\*



Impact  
(1X)

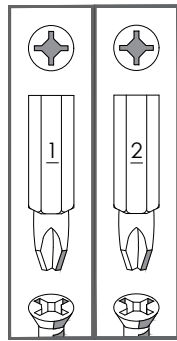

Screwdriver Bits  
(2X)

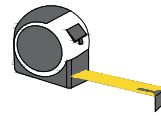

Measuring Tape  
(1X)



Screwdriver Bit  
Quadrex 6" #2 (1X)



Pencil  
(1X)



08375.58.SACn1.6V : FRAME & SASH Hardware bag

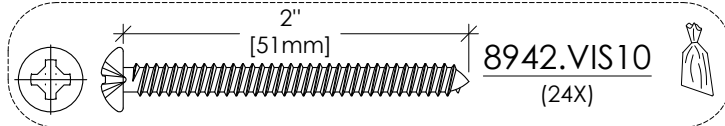

8942.VIS10  
(24X)



09750.00.INST.6VMP : Installation bag

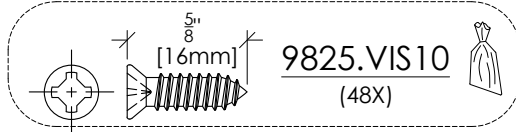

9825.VIS10  
(48X)

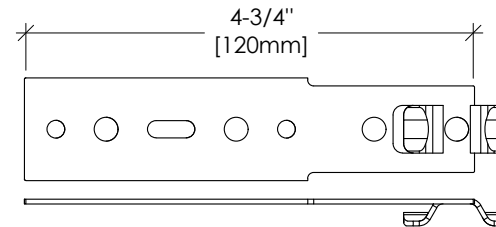

9859  
(24X)



STEP:  
**5**

(Continued) Frame Assembly

REVISION:  
2020/05/28

PAGE:  
P13

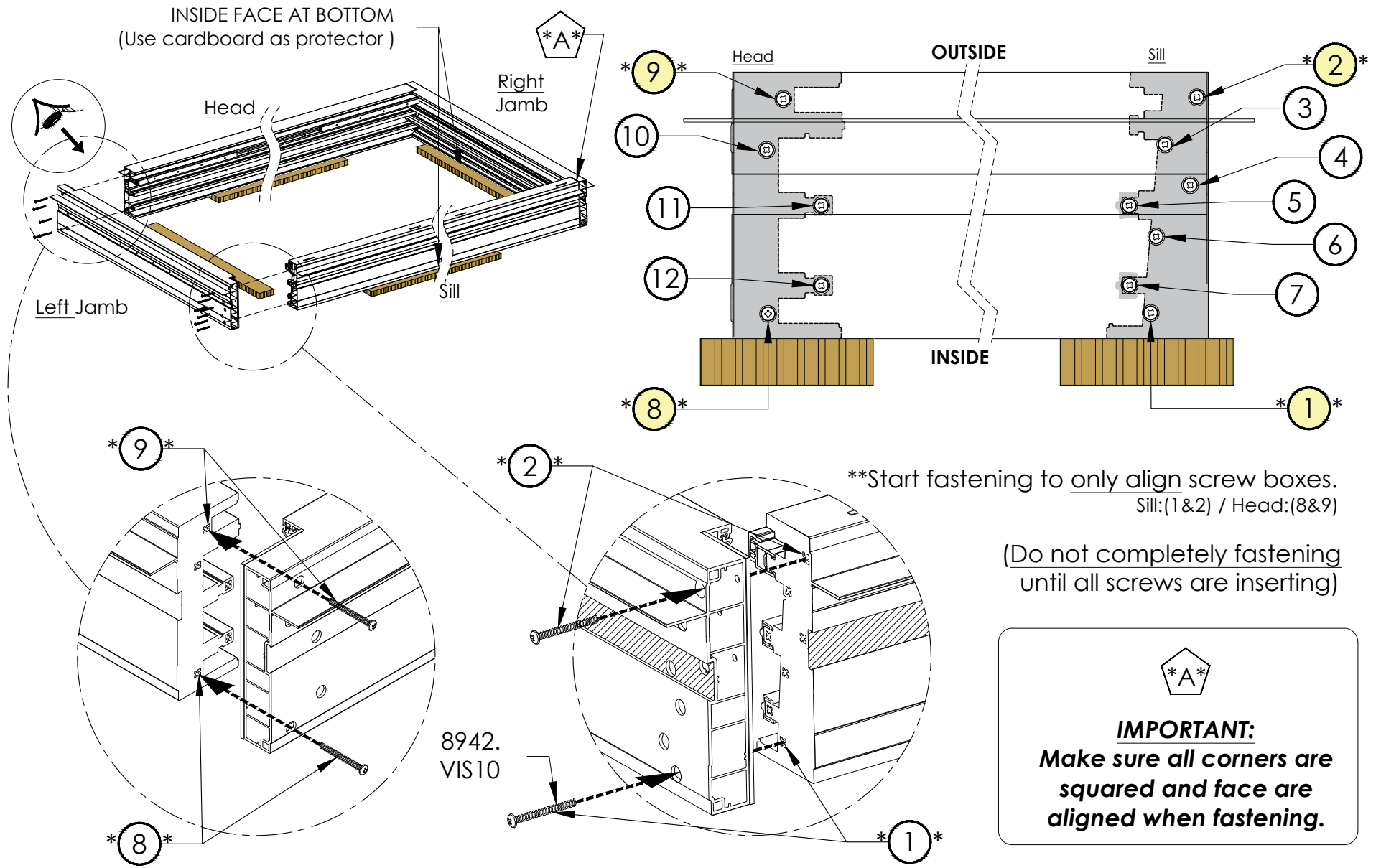





STEP:  
**5**

(Continued) Frame Assembly

REVISION:  
2020/05/28

PAGE:  
P14

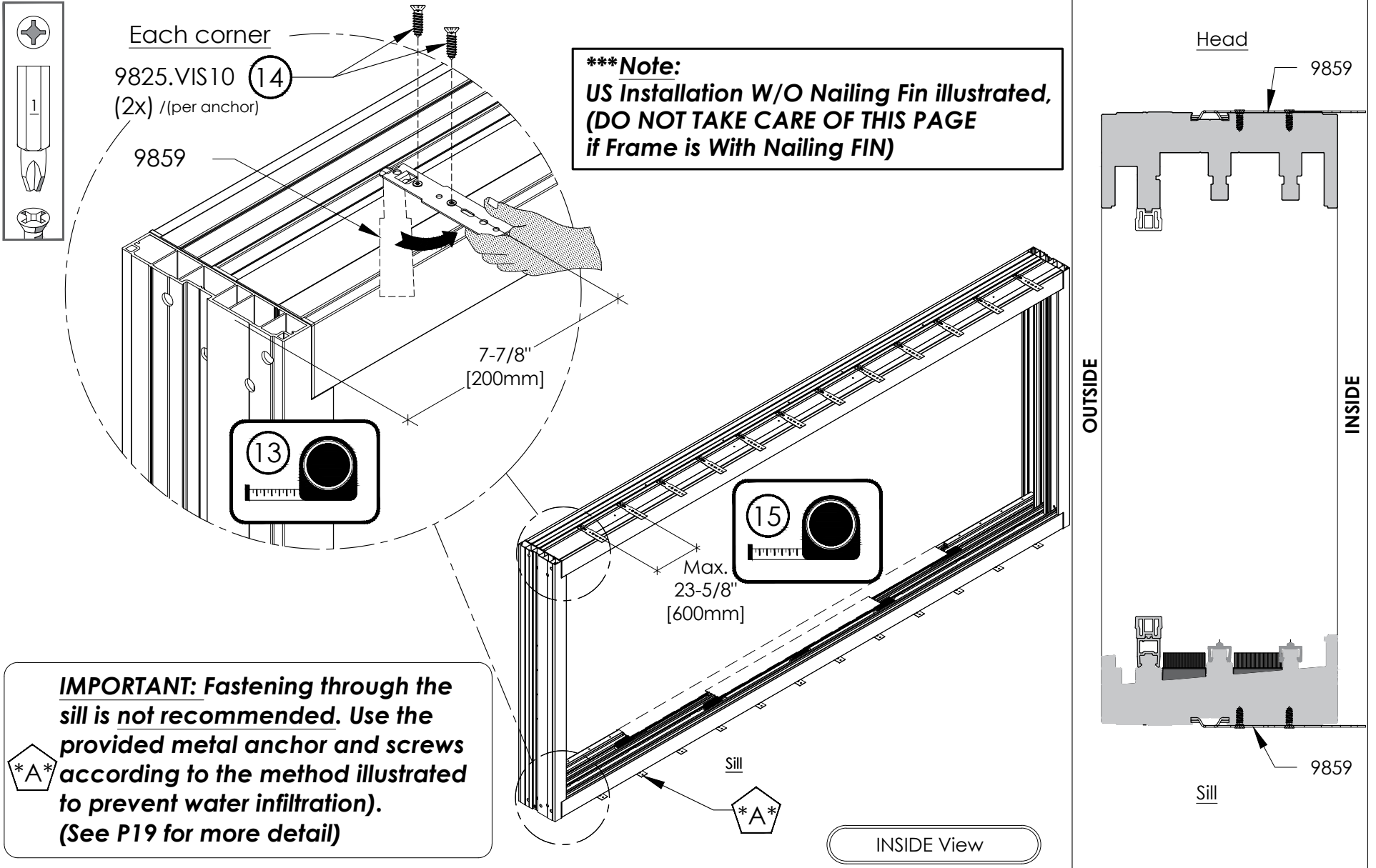

**IMPORTANT: Fastening through the sill is not recommended. Use the provided metal anchor and screws according to the method illustrated to prevent water infiltration. (See P19 for more detail)**





STEP:  
**6**

Installation of the Frame

REVISION:  
2020/05/28

PAGE:  
P15

\*Tools and hardware required for this step\*



Impact  
(1X)

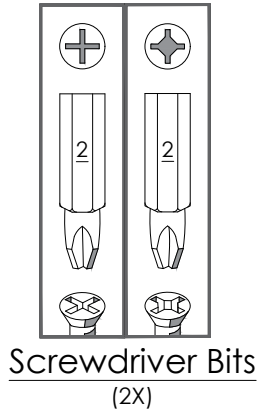

Screwdriver Bits  
(2X)

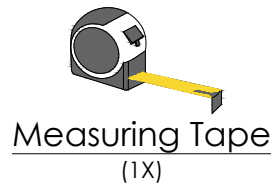

Measuring Tape  
(1X)

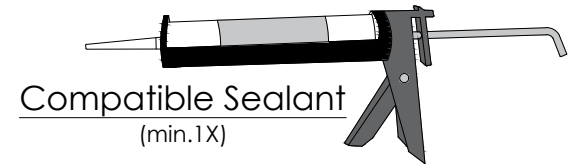

Compatible Sealant  
(min.1X)



Screwdriver Bit  
Quadrex 6" #2 (1X)

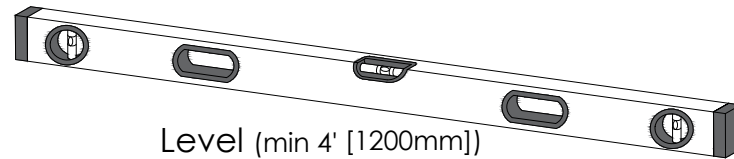

Level (min 4' [1200mm])  
(1X)

09750.00.INST.6VMP : Installation bag

3" [76mm] 9683.VIS10 (18X)

1 1/2" [38mm] 9759.VIS08 (24X)

**IMPORTANT:**  
Hardwares are provided for  
Installation in Wood box.  
For concrete application:  
screws are NOT provided.



STEP:  
**6**

(Continued) Installation of the Frame

REVISION:  
2020/05/28

PAGE:  
P16

**\*\*\*\* CAUTION: The product must be installed in conformance with the following standards USA: AAMA 2400, AAMA 2410 and IPCB.**

**\*\*\*\* Be sure to also follow local applicable building code requirements. \*\*\*\***

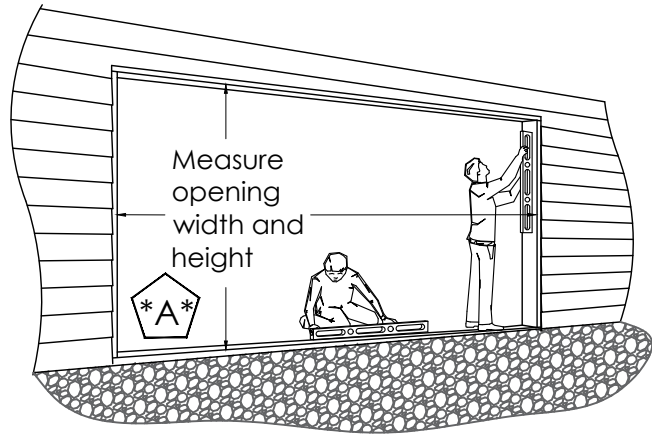

**1** An improper fit will impact the performance of the door. (too narrow or too large)

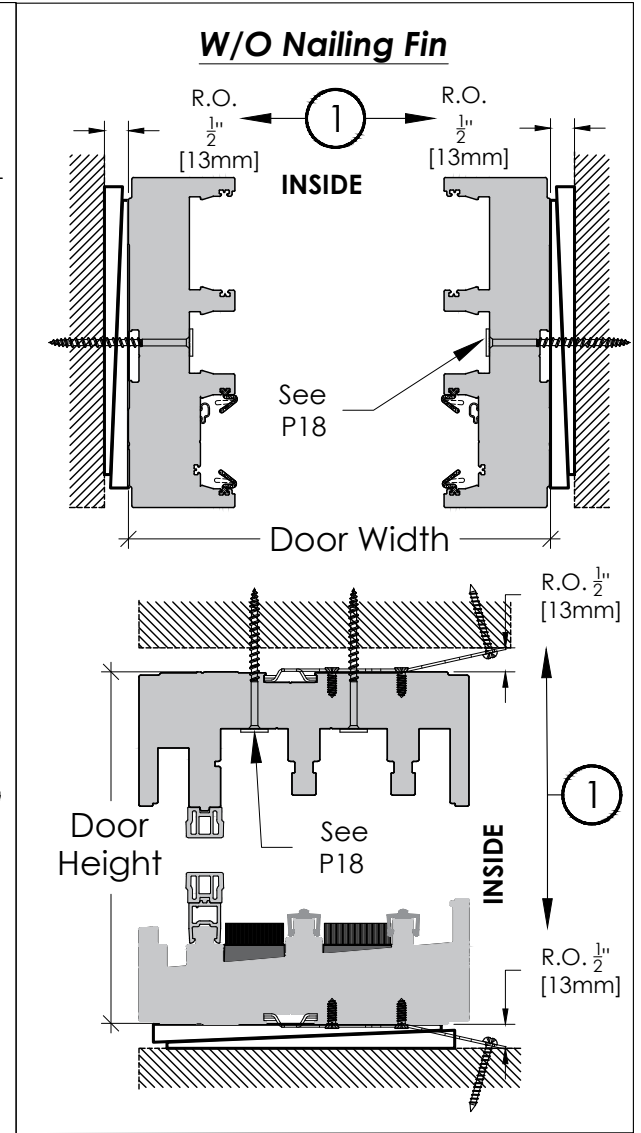
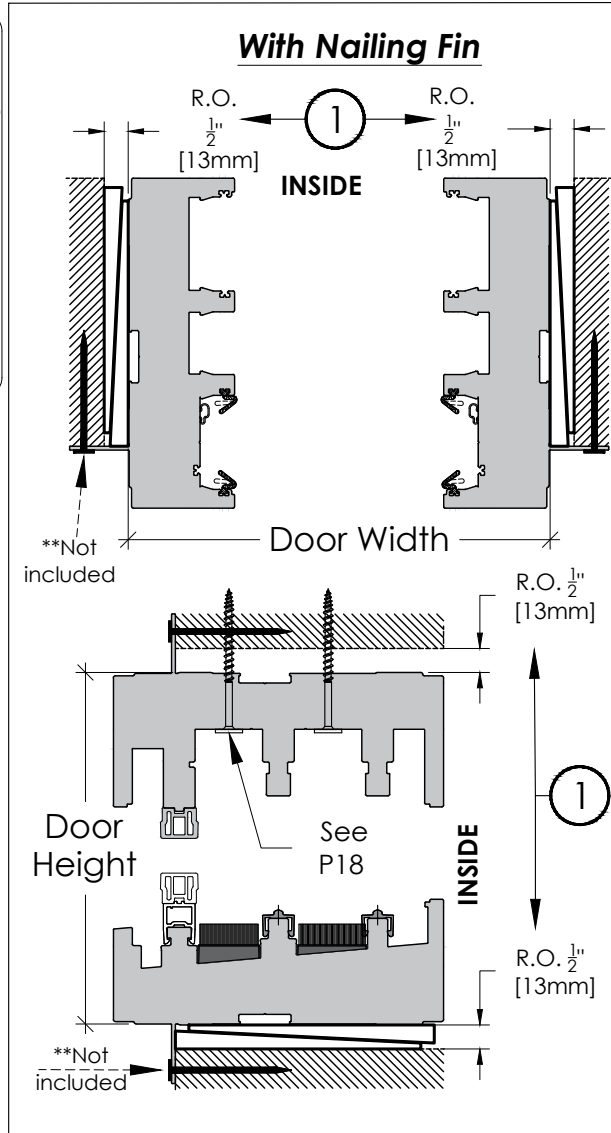

**\*\*\*Note: US Installation illustrated\*\*\***



## (Continued) Installation of the Frame

\*\*\*OUTSIDE View\*\*\*

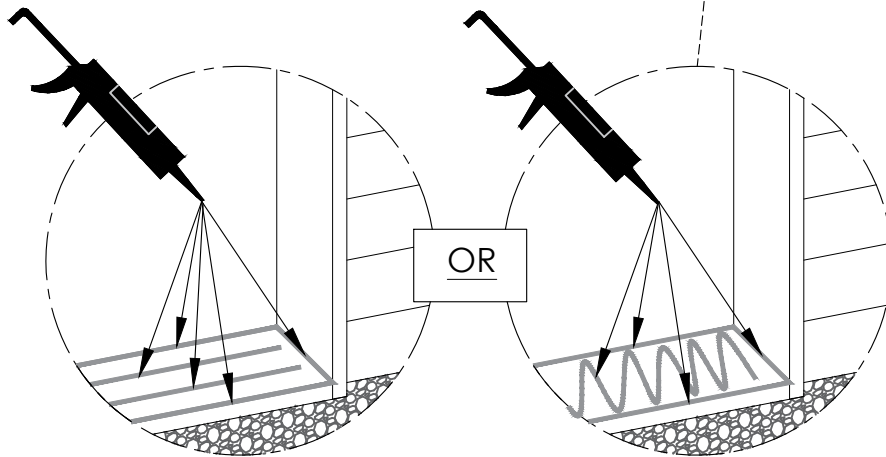
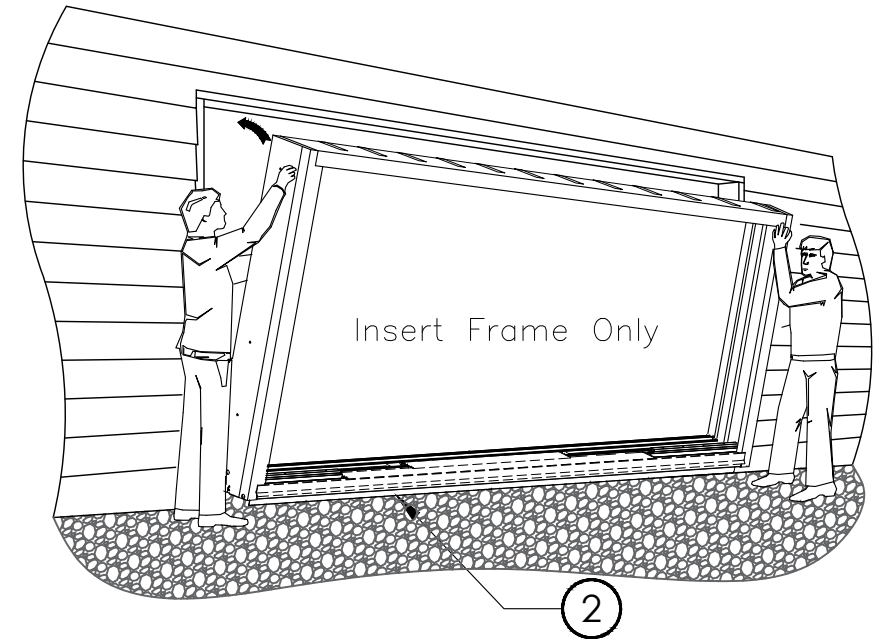
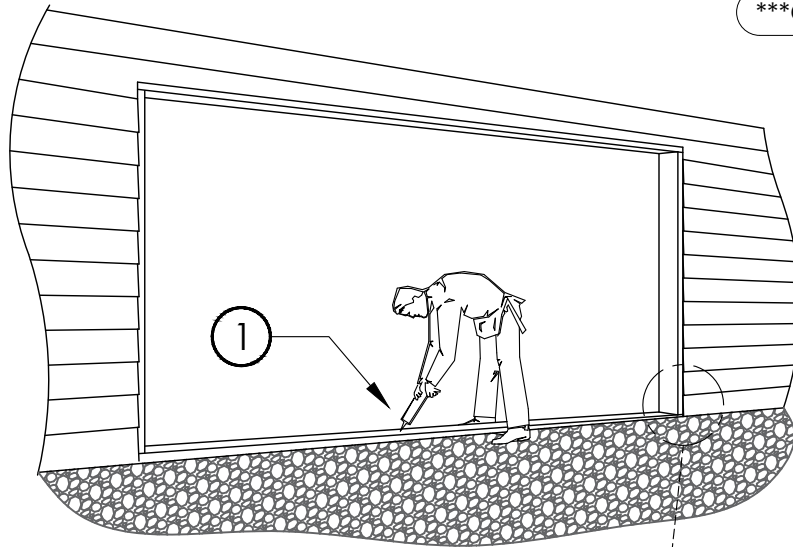
Insert frame in the Rough Opening:

- 1) Apply generous bead of good quality sealant all along the sill.  
(Min Sealant bead =  $\frac{5}{8}$ " [15mm]).
- 2) Install the door frame in the opening, sill first.  
\*\*\*Make sure that the sealant joint is continuous and sufficient between the door sill and the floor.



STEP:  
**6**

(Continued) Installation of the Frame

REVISION:  
2020/05/28

PAGE:  
P18



**ATTENTION:** Improper shimming will bow the jambs. Make sure jambs are straight for optimal performance. (\*Do not install Shims at header).

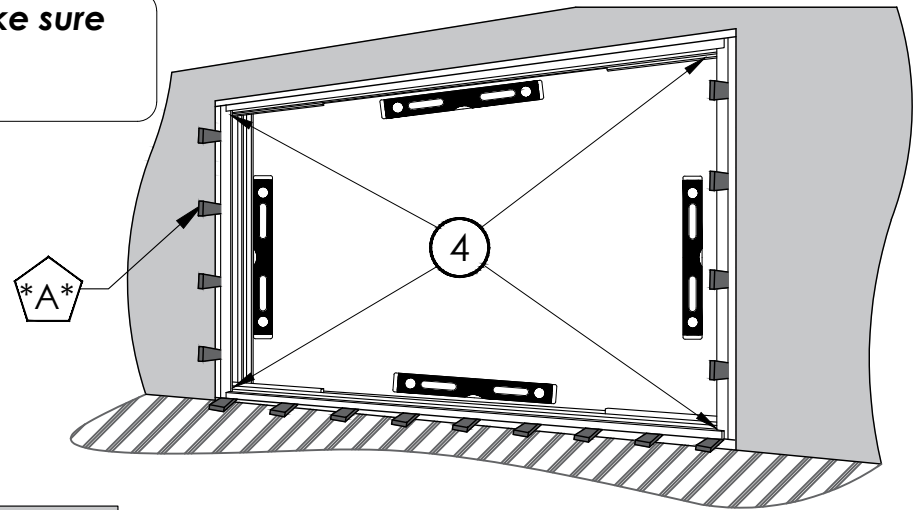
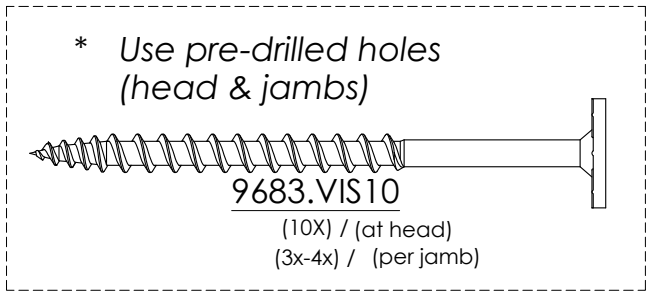

INSIDE View

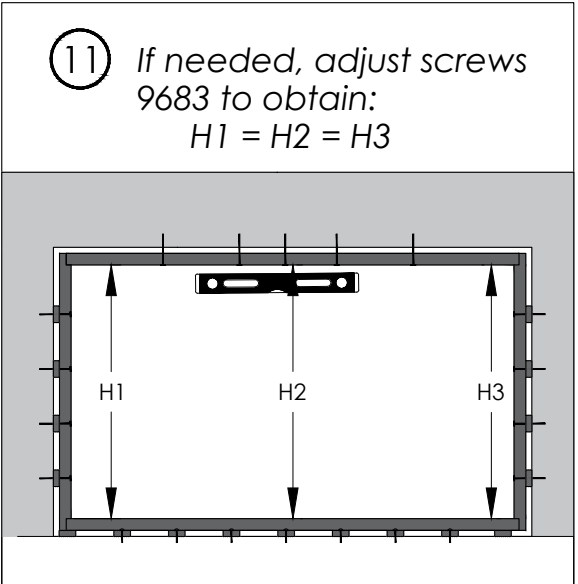
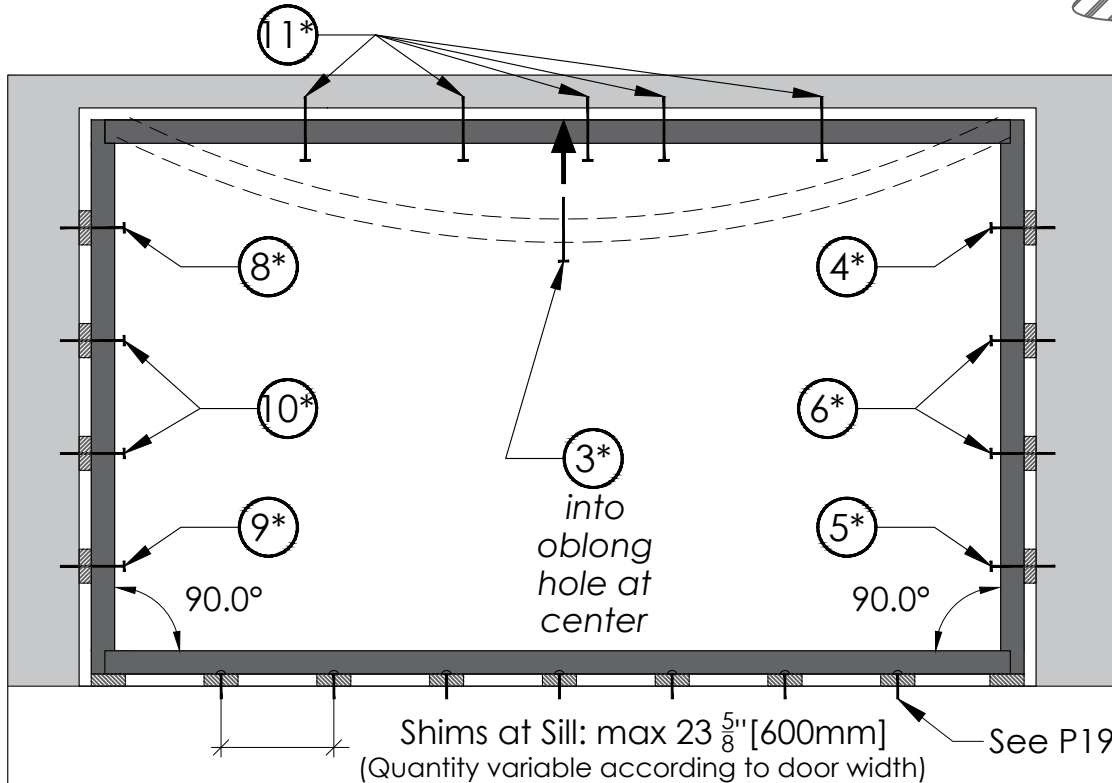



STEP:  
**6**

(Continued) Installation of the Frame

REVISION:  
2020/05/28

PAGE:  
P19

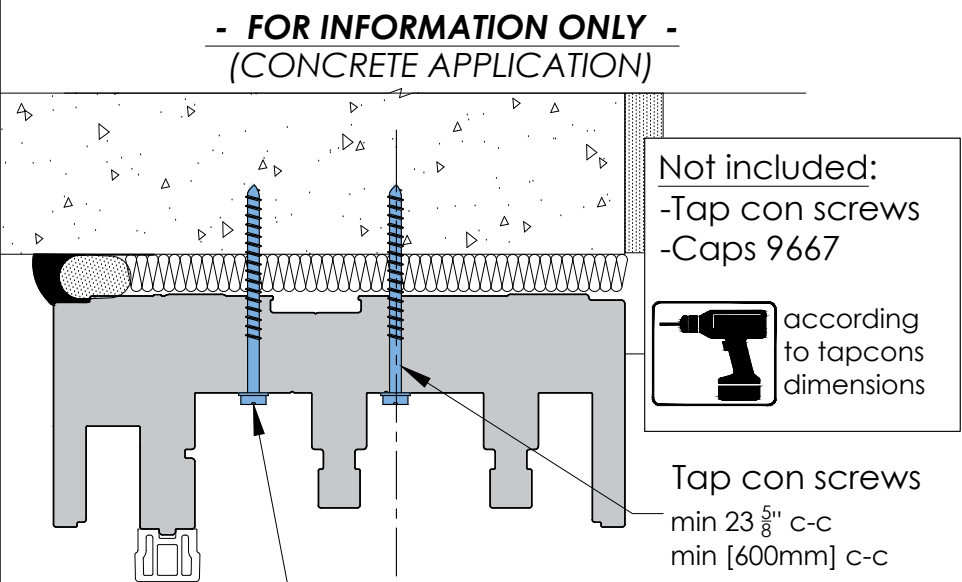
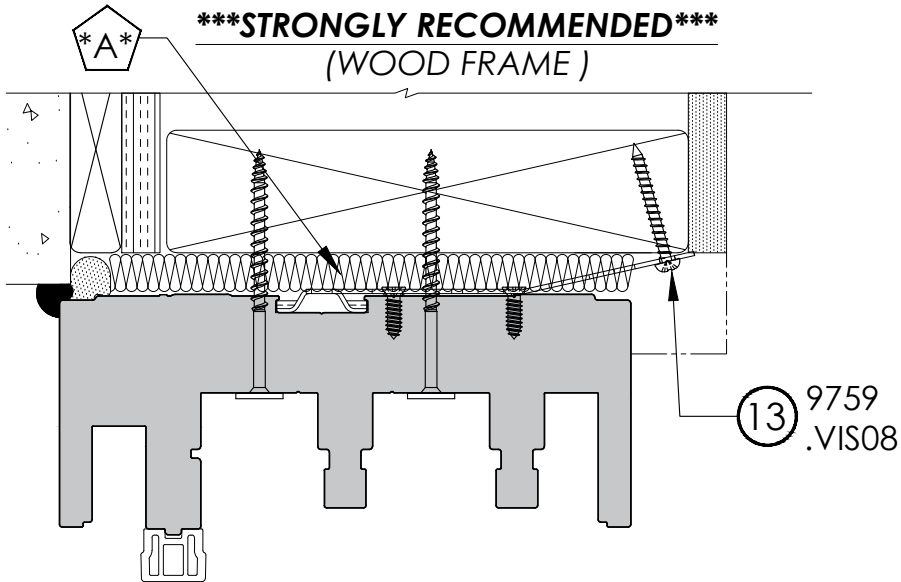

**\*A\*** Do not use shims at the header. A gap is necessary for building settlement.

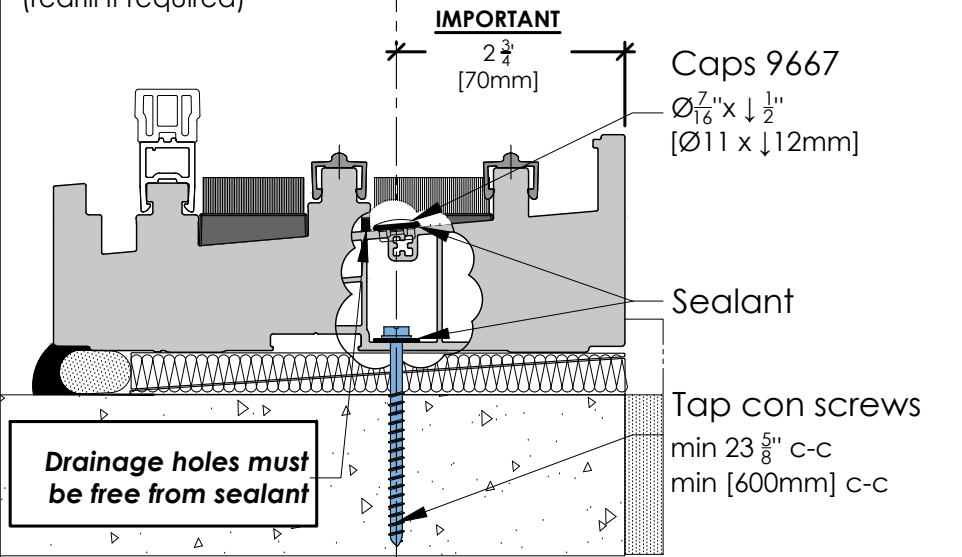
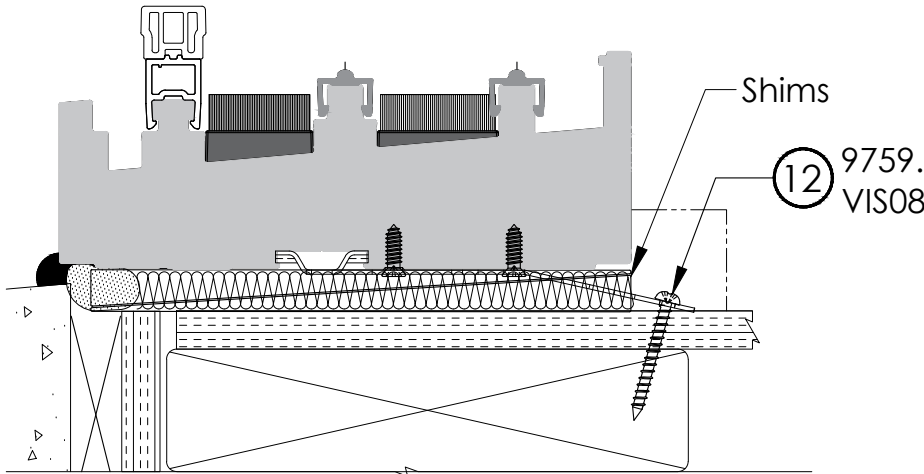



STEP:  
**6**

(Continued) Installation of the Frame

REVISION:  
2020/05/28

PAGE:  
P20

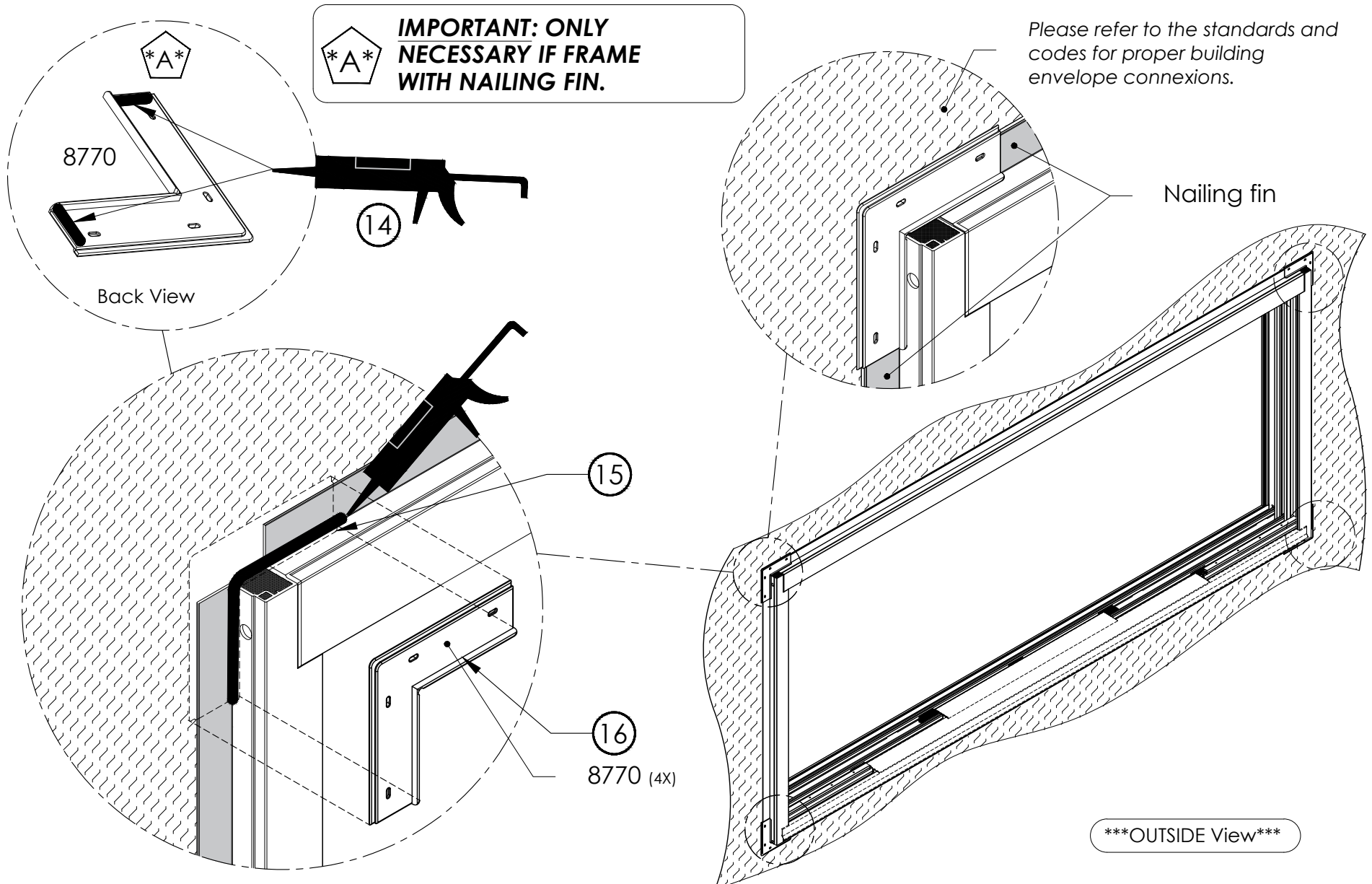



STEP:  
**7**

Installation of Fixed Sashes

REVISION:  
2020/05/28

PAGE:  
P21

\*Tools and components required for this step\*



Impact  
(1X)

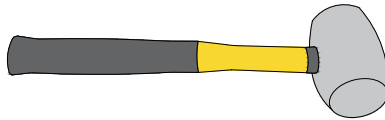

Rubber Mallet  
(1X)

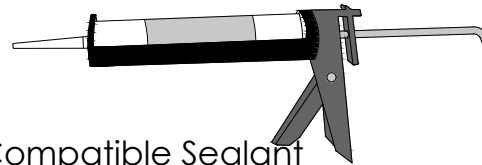

Compatible Sealant  
(min.1X)



Screwdriver Bit  
Quadrex 6" #2 (1X)

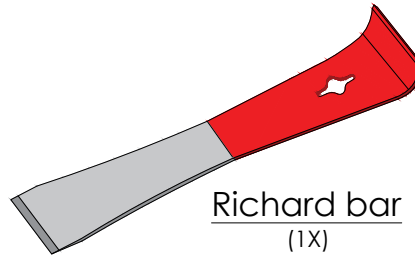

Richard bar  
(1X)

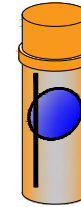

Invisible Lubricant  
Silicone  
(1X)

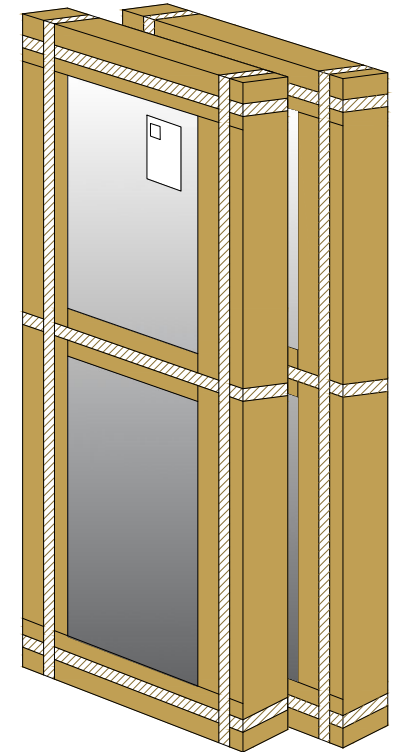

FIXED Sash Box  
(2X)



08375.58.SACn1.6V : FRAME & SASH Hardware bag

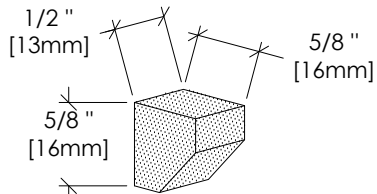

8784  
(2X)

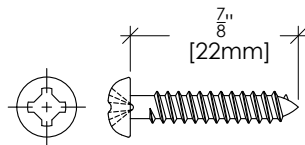

9876.VIS08  
(8X)

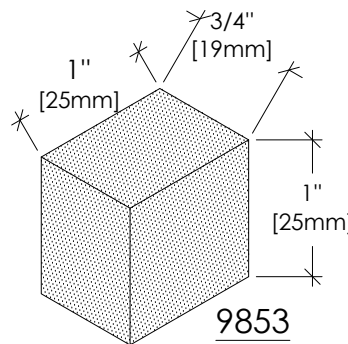

9853  
(10X)

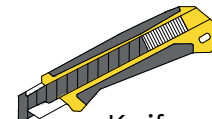

Knife  
(1X)

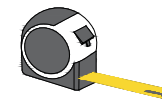

Measuring Tape  
(1X)

\*If painted door (IN=Inside), rather use parts on red bag in Sash box.\*



9667.CAPUC  
(8X)





STEP:  
**7**

(Continued) Installation of Fixed Sashes

REVISION:  
2020/05/28

PAGE:  
P22

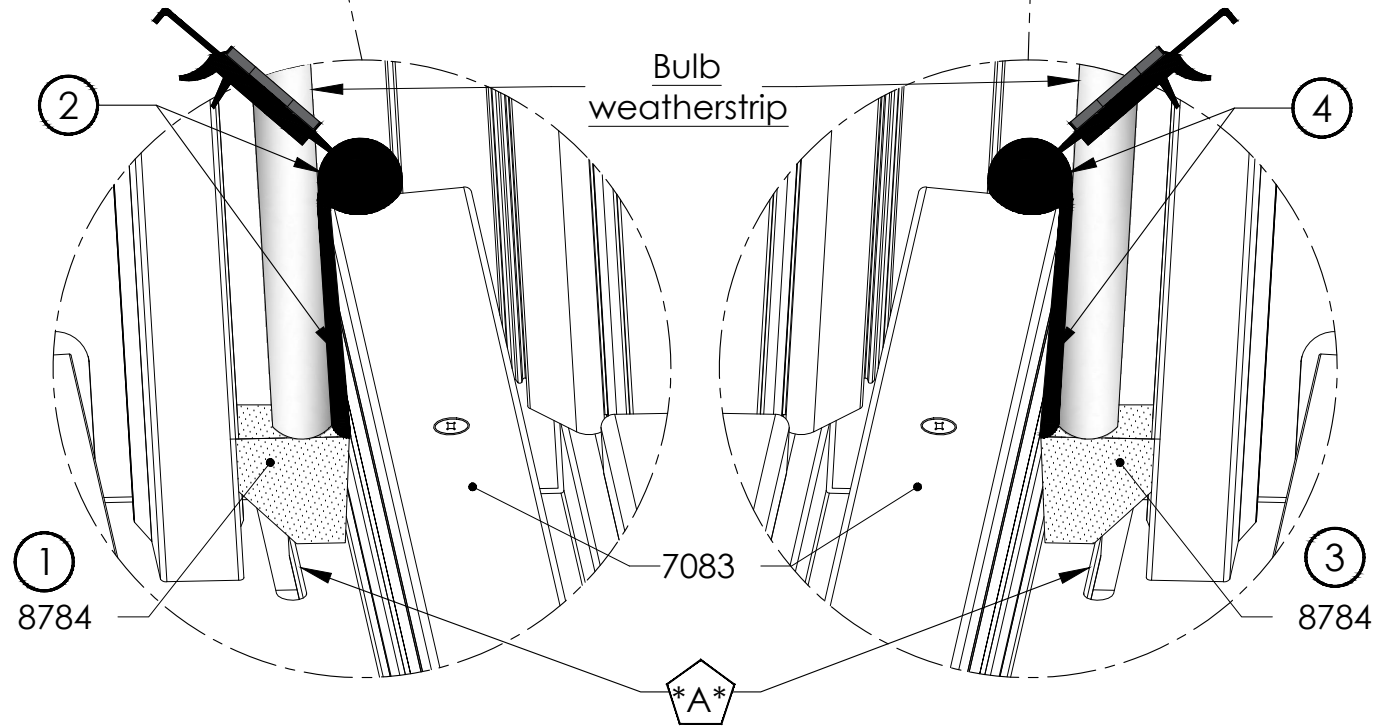
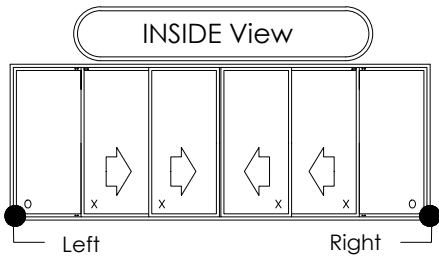
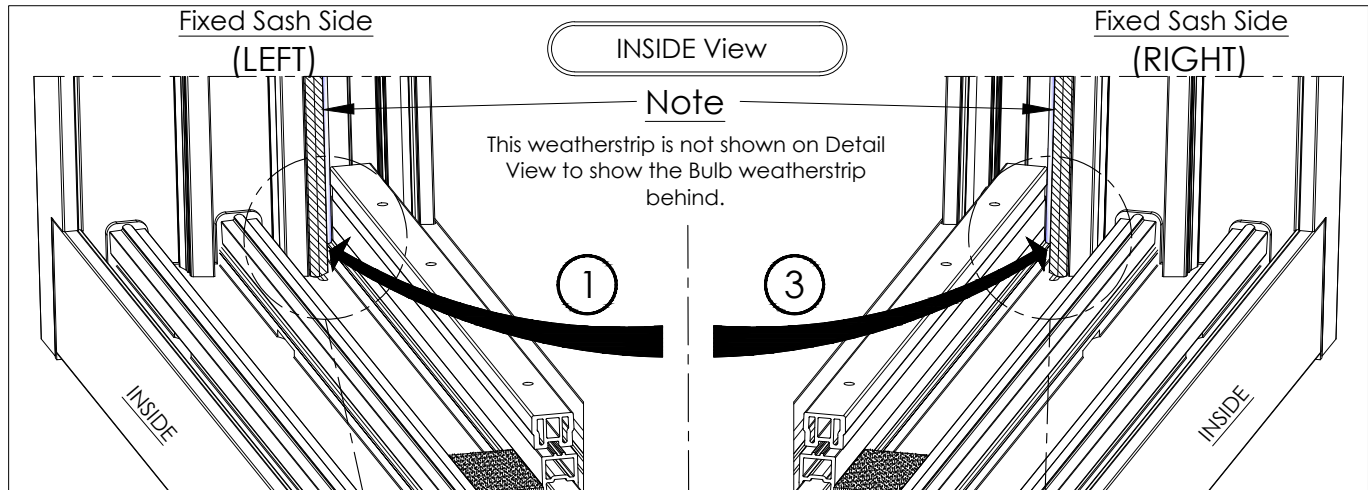
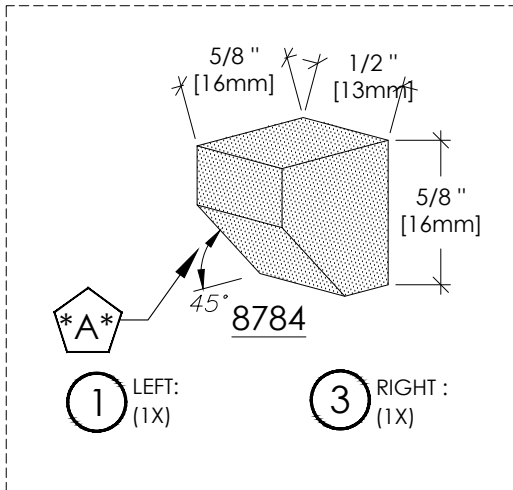

**\*A\***

**IMPORTANT:**  
Drainage holes  
must be free.

Pay attention to the  
angle on part 8784  
when positioning.



(Continued) Installation of Fixed Sashes

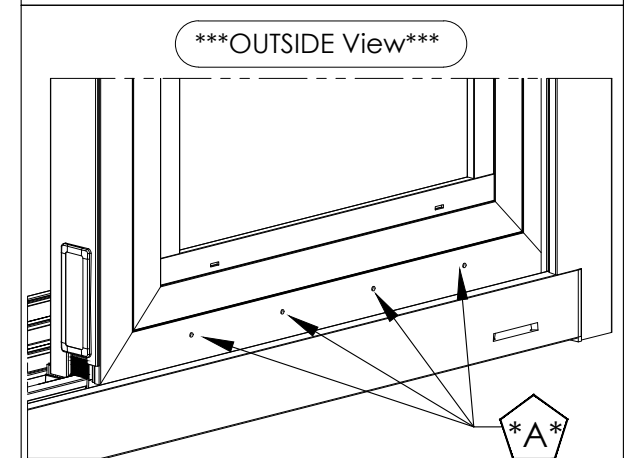
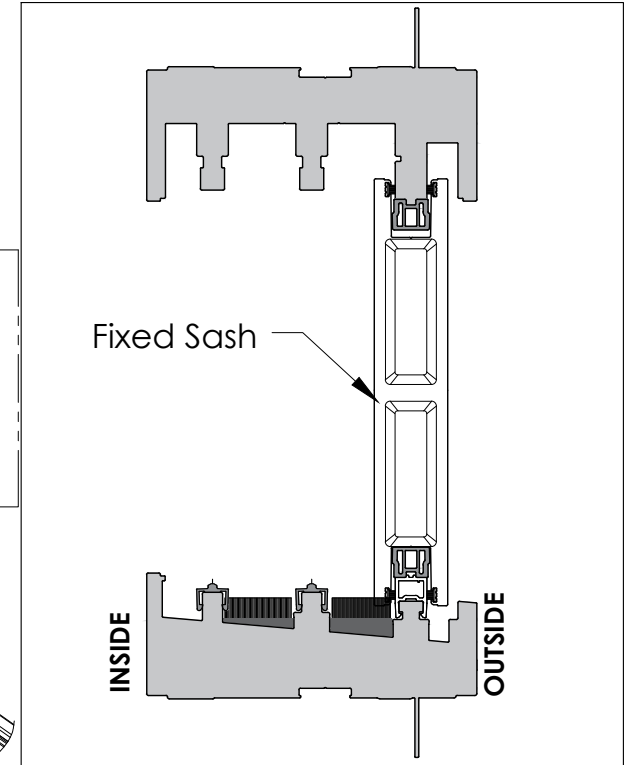
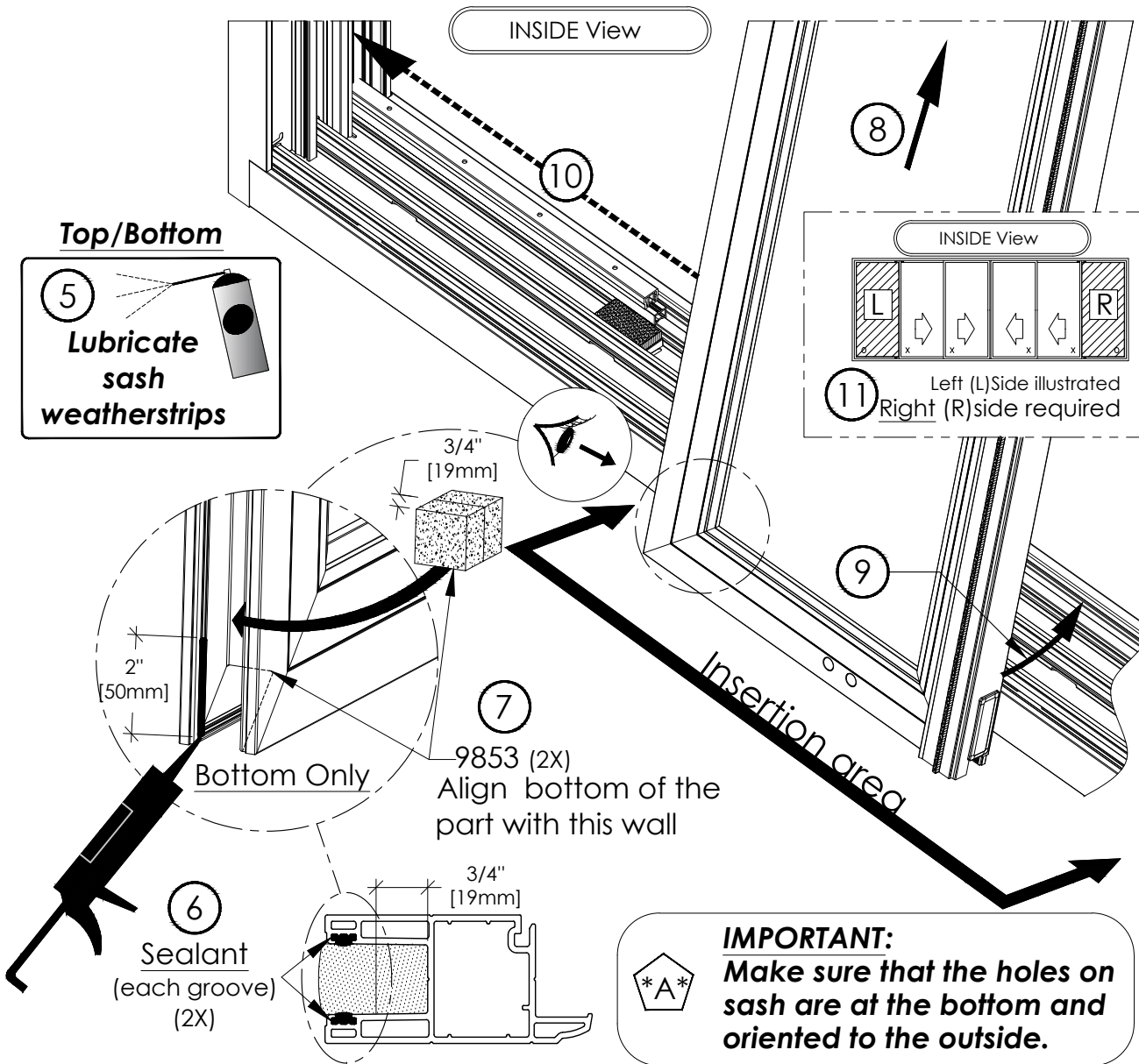



(Continued) Installation of Fixed Sashes

**IMPORTANT:**  
**Check the squaring of the sash before fastening. (If necessary, straighten the head with the adjustment screws 9683 - see step 6).**

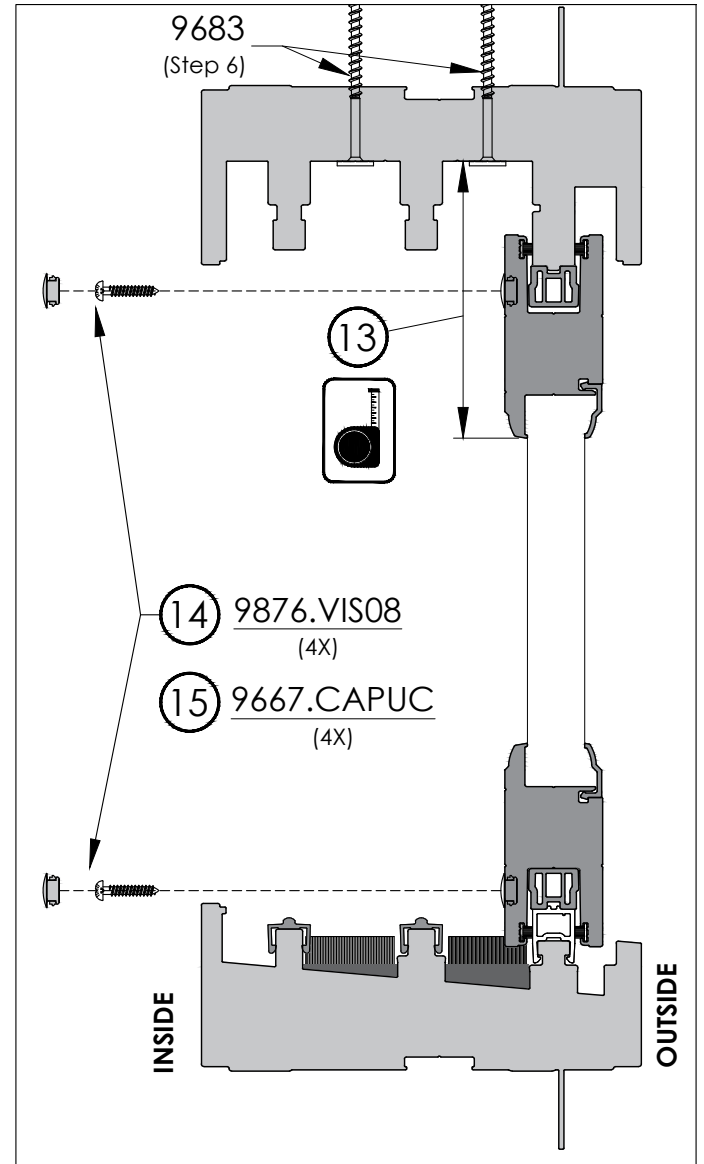
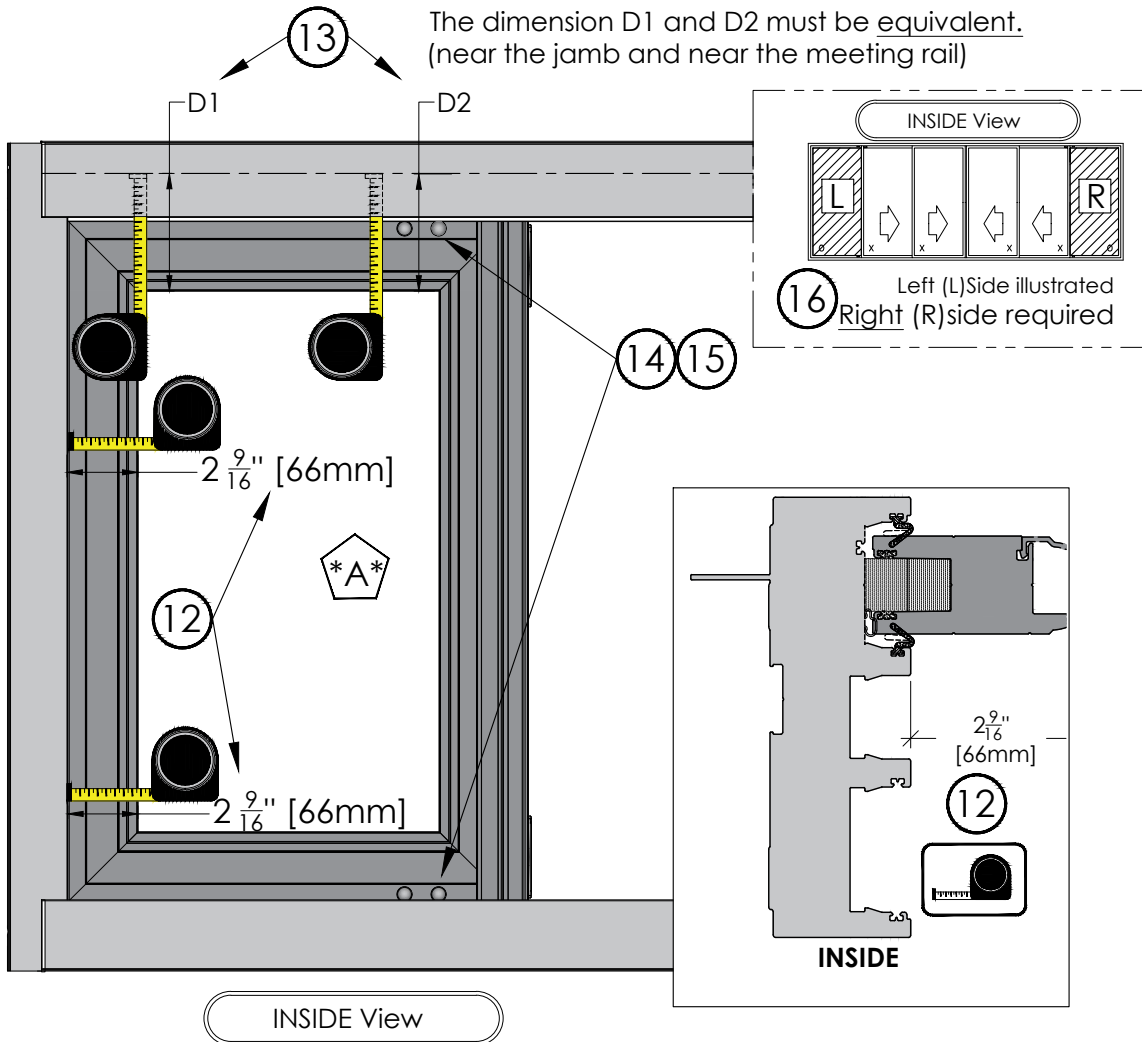



STEP: **7**

(Continued) Installation of Fixed Sashes

REVISION: 2020/05/28

PAGE: P25

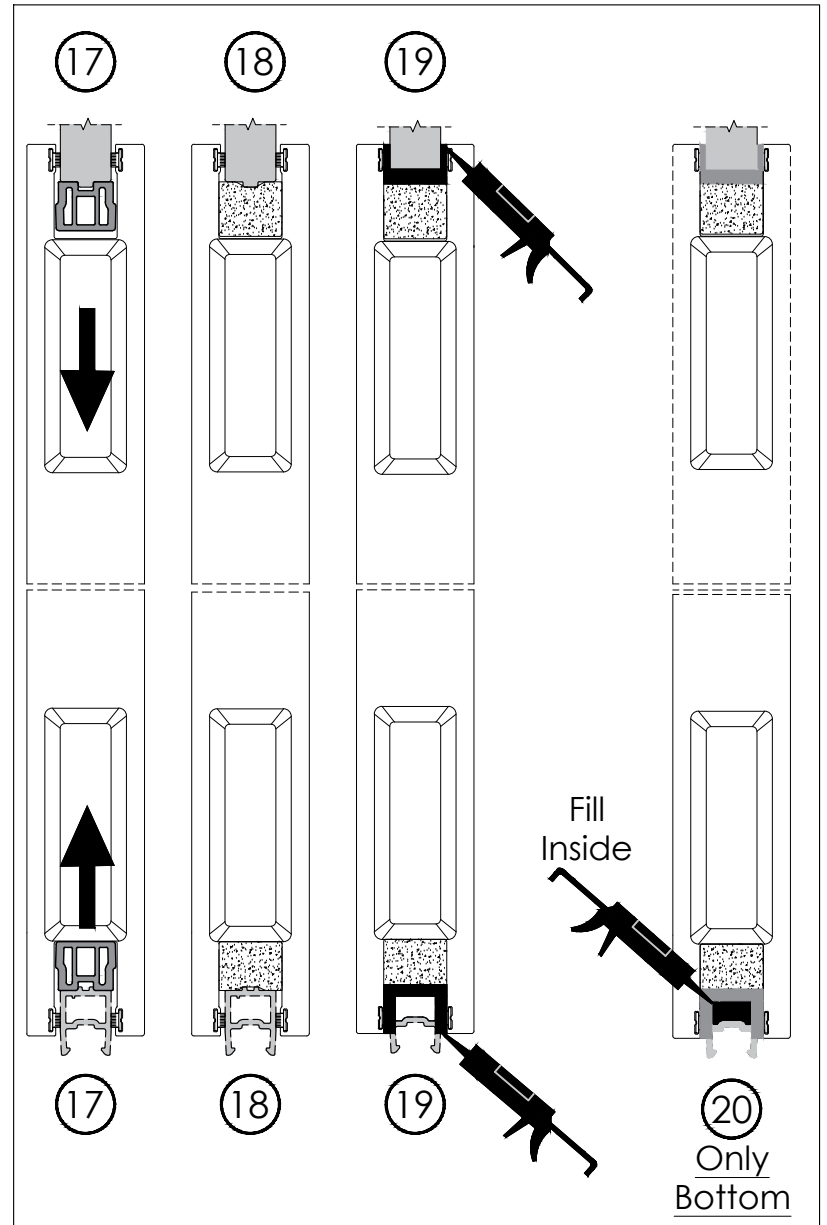
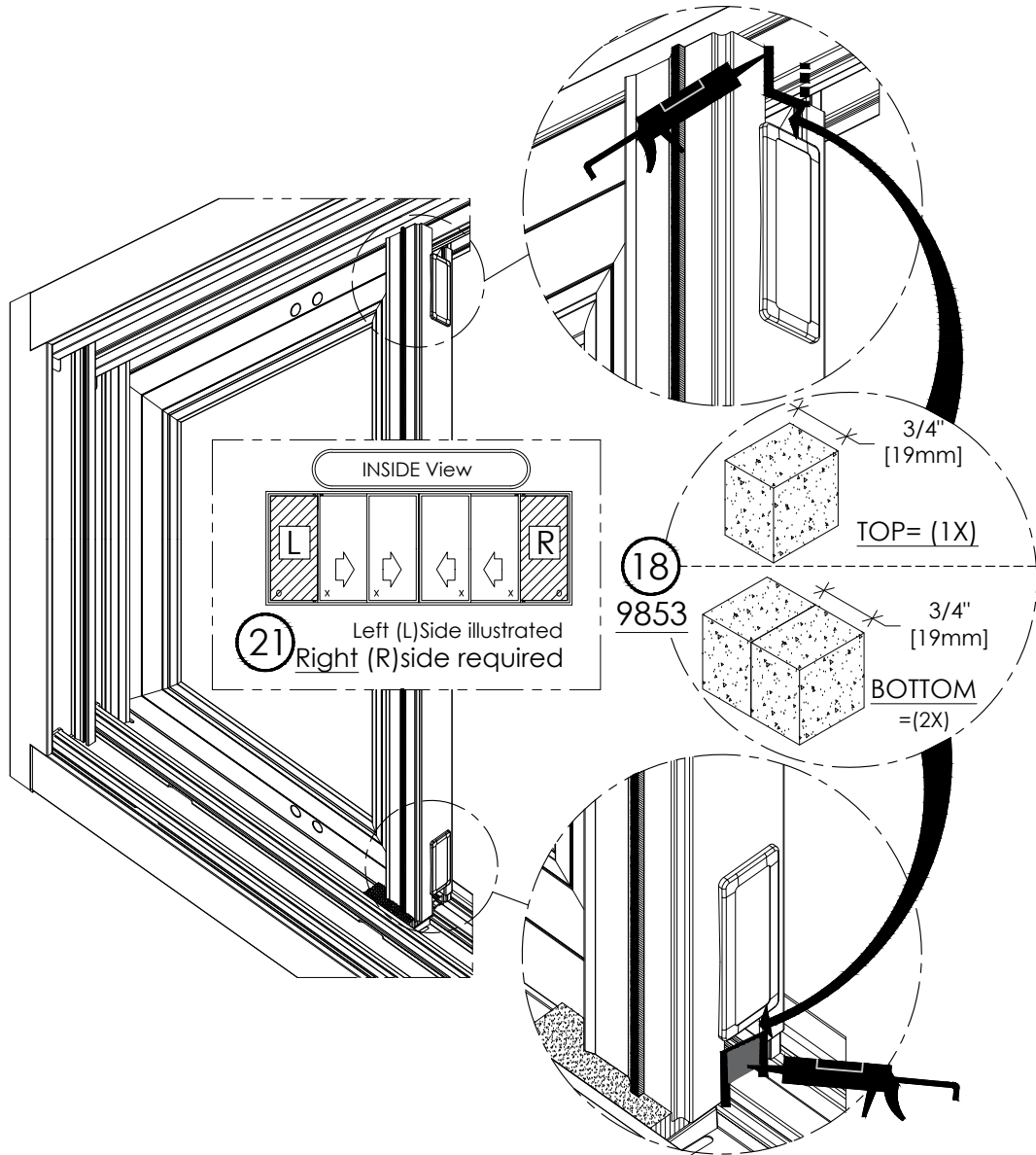



STEP:  
**8**

# Installation of Central Sashes & Head Tracks #8321

REVISION:  
2020/05/28

PAGE:  
P26

\*Tools and components required for this step\*

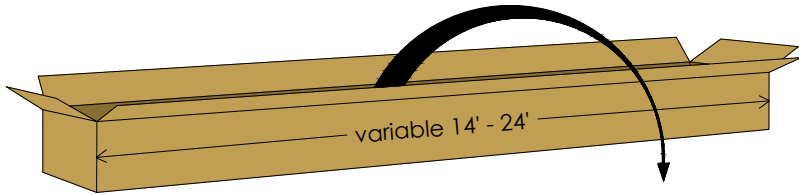

**8321**  
(3X)



Impact  
(1X)

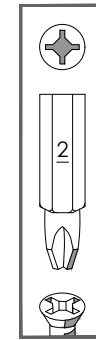

Screwdriver Bit  
(1X)

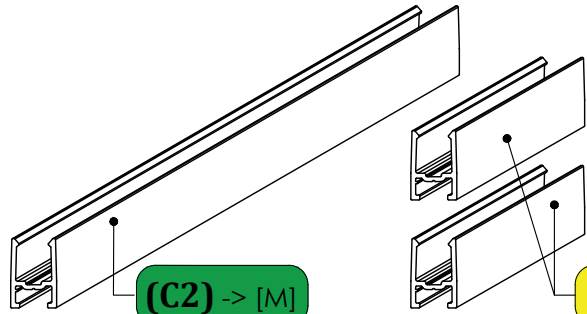

**(C2) -> [M]**

**(C1) -> [F]**

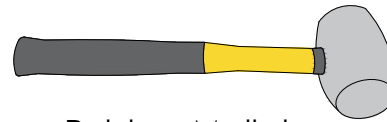

Rubber Mallet  
(1X)

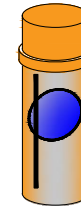

Invisible Lubricant  
Silicone  
(1X)

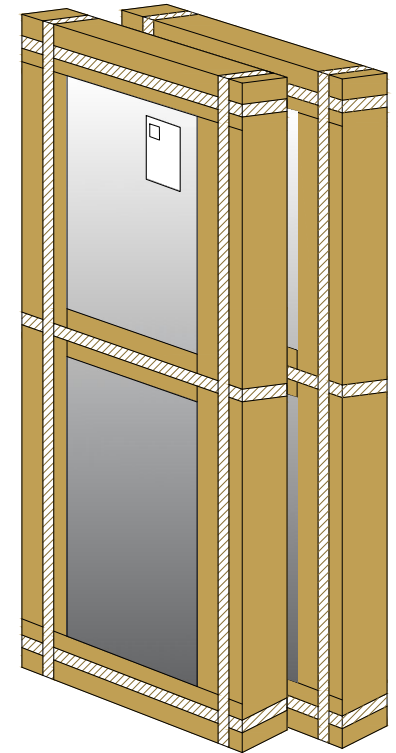

CENTRAL Sash Box  
(2X)

**08375.58.SACn1.6V : FRAME & SASH Hardware bag**

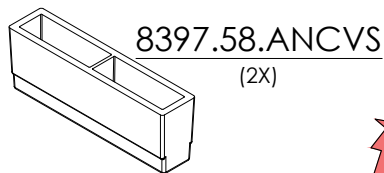

**8397.58.ANCVS**  
(2X)

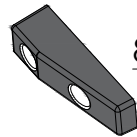

**8389.ARREV**  
(2X)

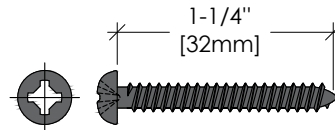

**8941.VIS08**  
(4X)  
**\*BLACK\***

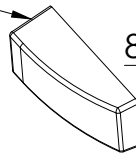

**8389.CAPEV**  
(2X)

*\*If painted door (IN=Inside), rather use parts on red bag in Sill box.\**

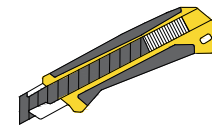

Knife  
(1X)



STEP:  
**8**

(Continued) Installation of Central Sashes & Head Tracks #8321

REVISION:  
2020/05/28

PAGE:  
P27

**\*A\***  
**ATTENTION:  
MUST BE DONE BEFORE  
INSERTING SASH IN FRAME.**

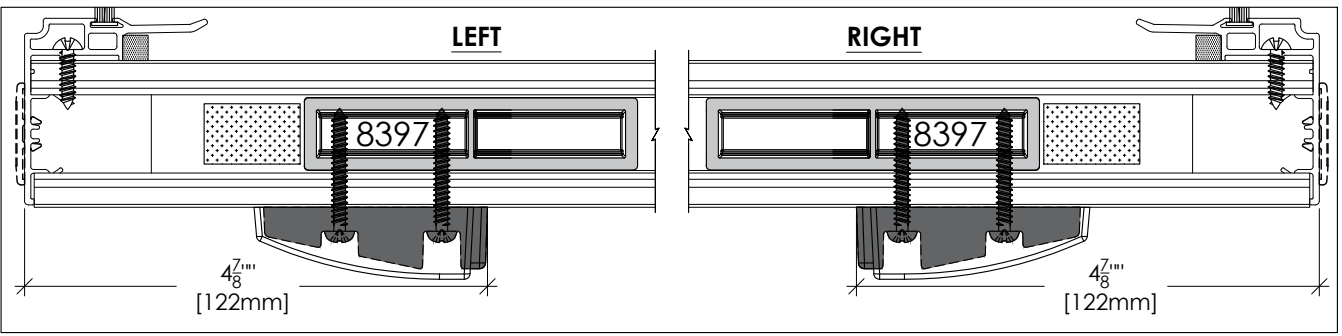
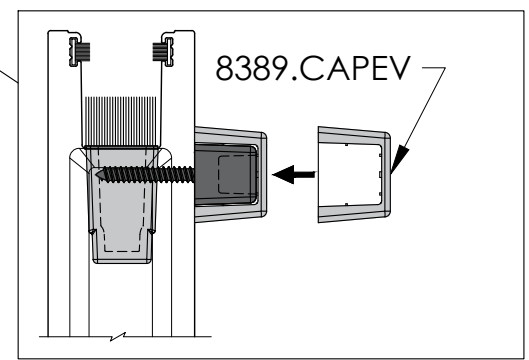
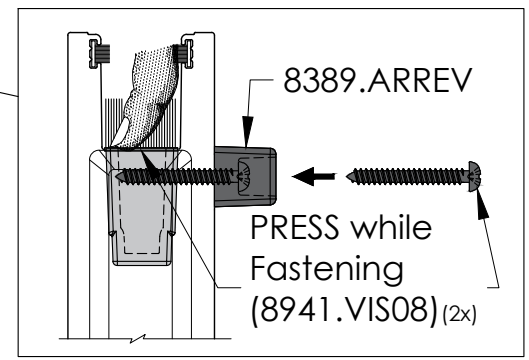
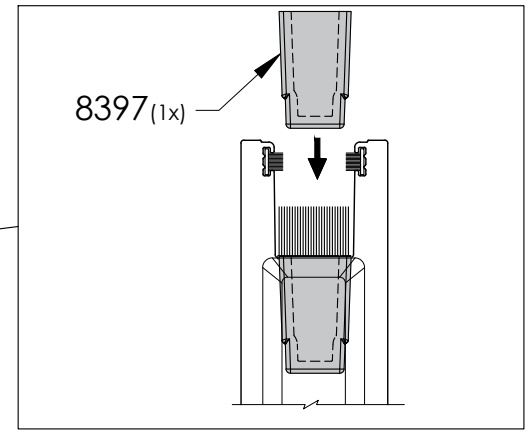
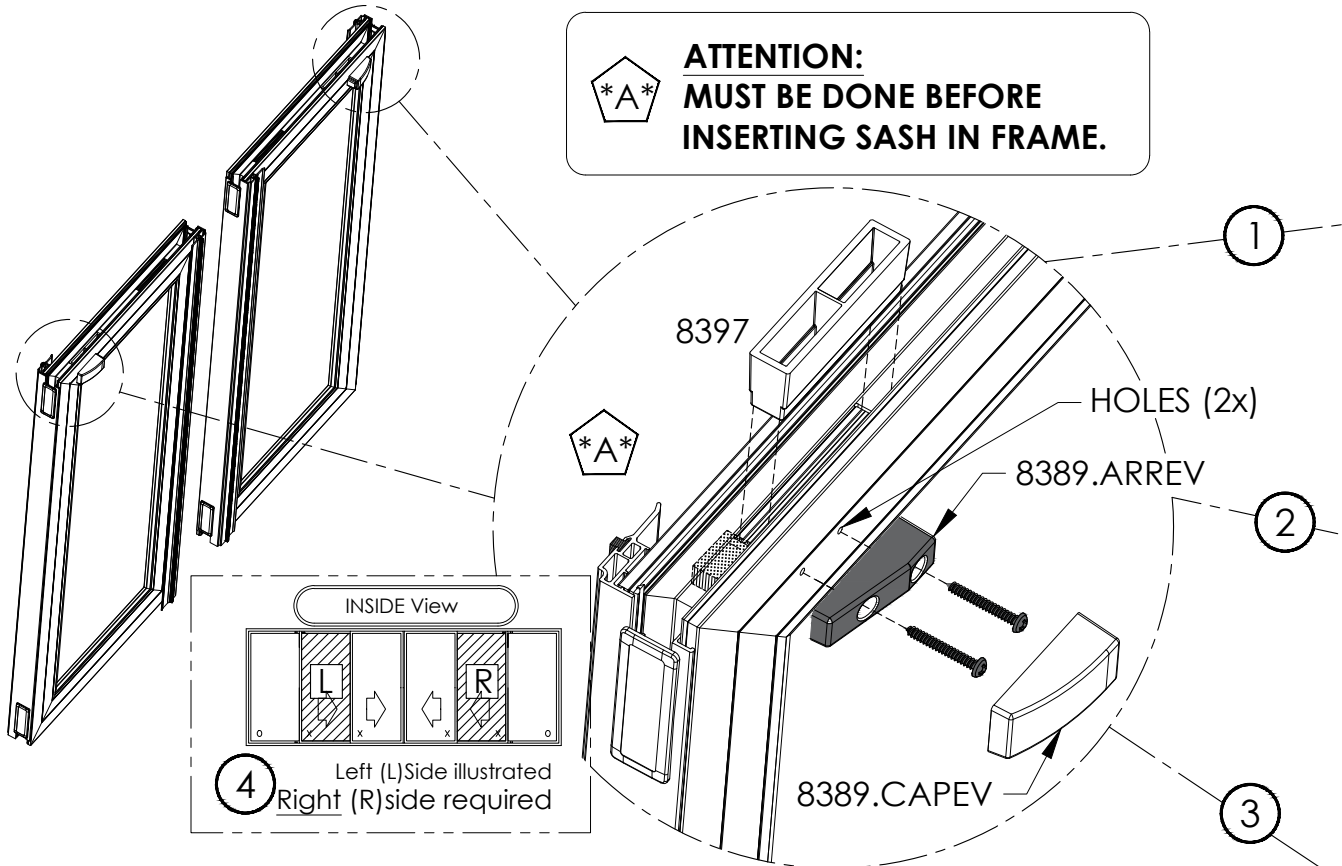



STEP: **8**

(Continued) Installation of Central Sashes & Head Tracks #8321

REVISION: 2020/05/28

PAGE: P28

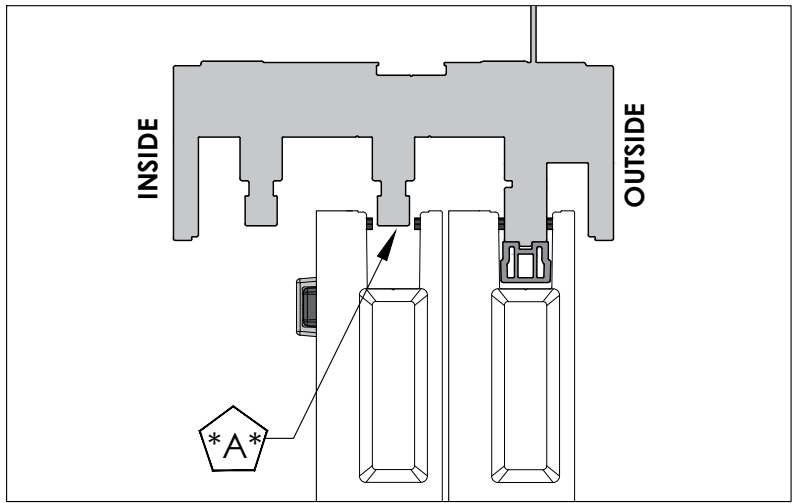
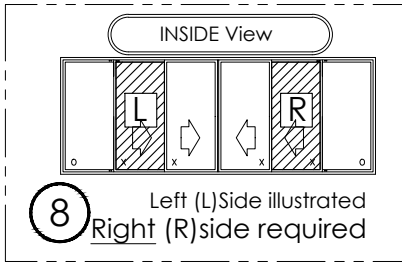
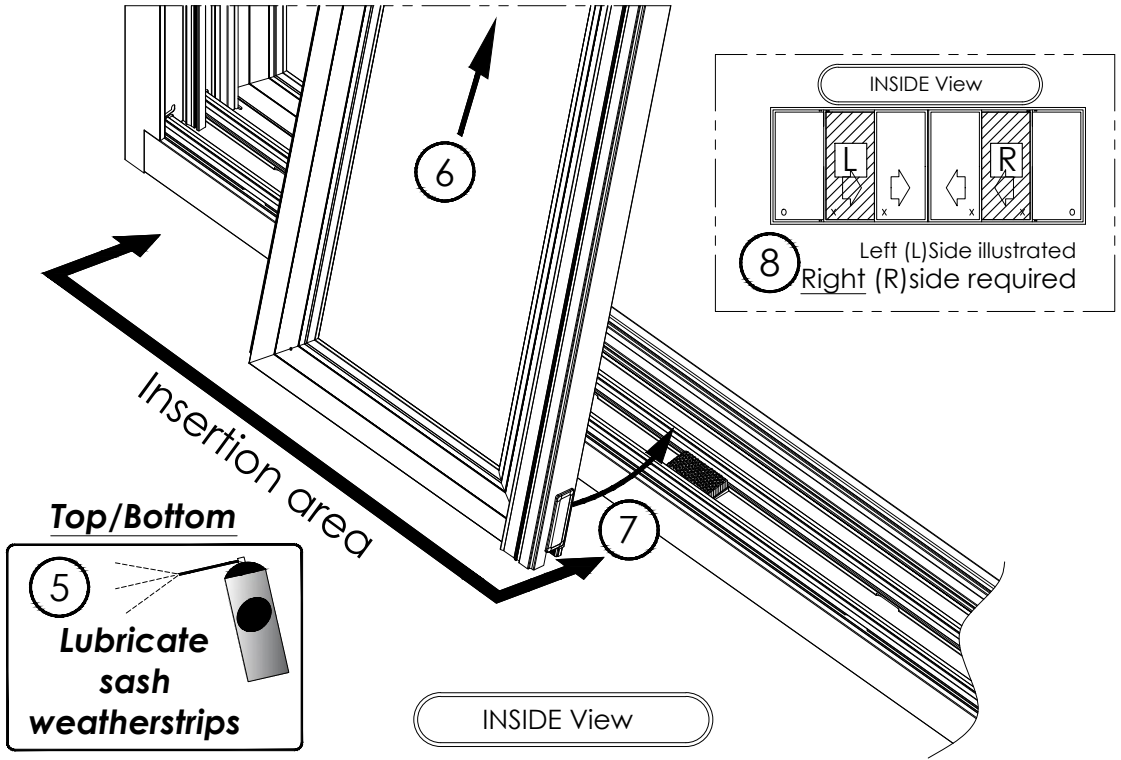

**IMPORTANT:** Sash header engagement is minimal at this stage. (The sash is free standing and could disengage from the header until head track is installed (see next page).

\*A\*

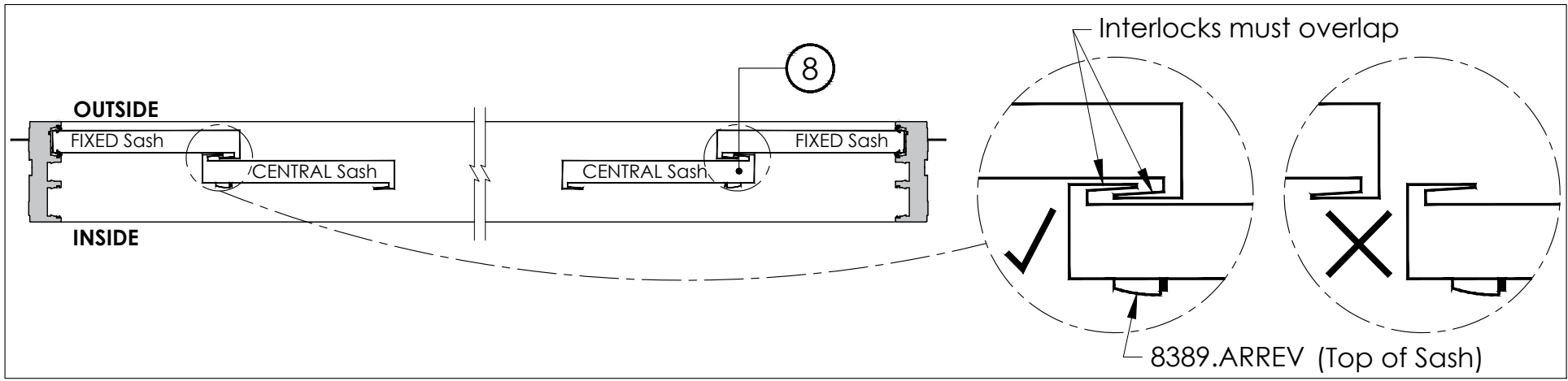



STEP:  
**8**

(Continued) Installation of Central Sashes & Head Tracks #8321

REVISION:  
2020/05/28

PAGE:  
P29

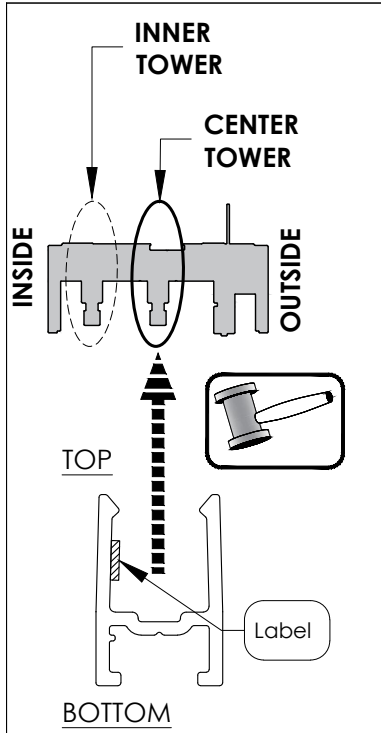

**Legend:**

**INNER TOWER:**  
**(I1) -> [F]**  
 = Part 1 (close to Fixed Sash)

**(I2) -> [M]**  
 = Part 2 (close to Mobile Sash)

**CENTER TOWER:**  
**(C1) -> [F]**  
 = Part 1 (close to Fixed Sash)

**(C2) -> [M]**  
 = Part 2 (close to Mobile Sash))

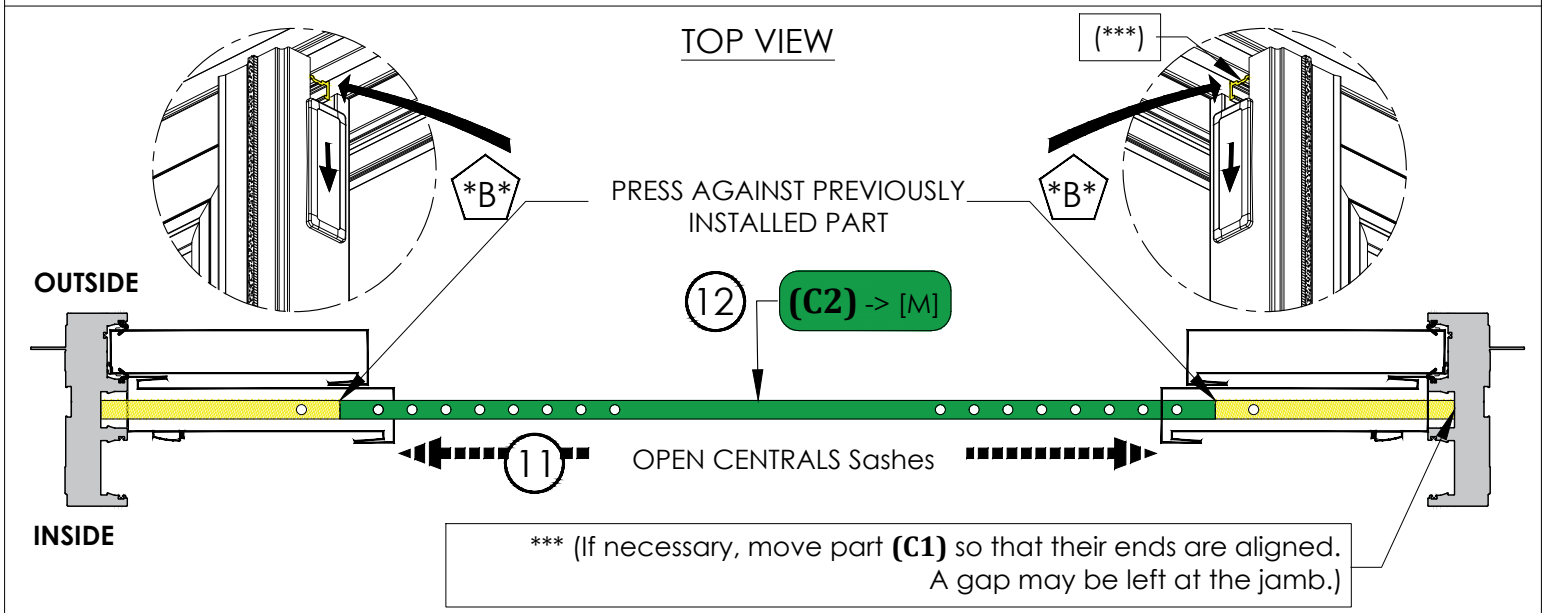
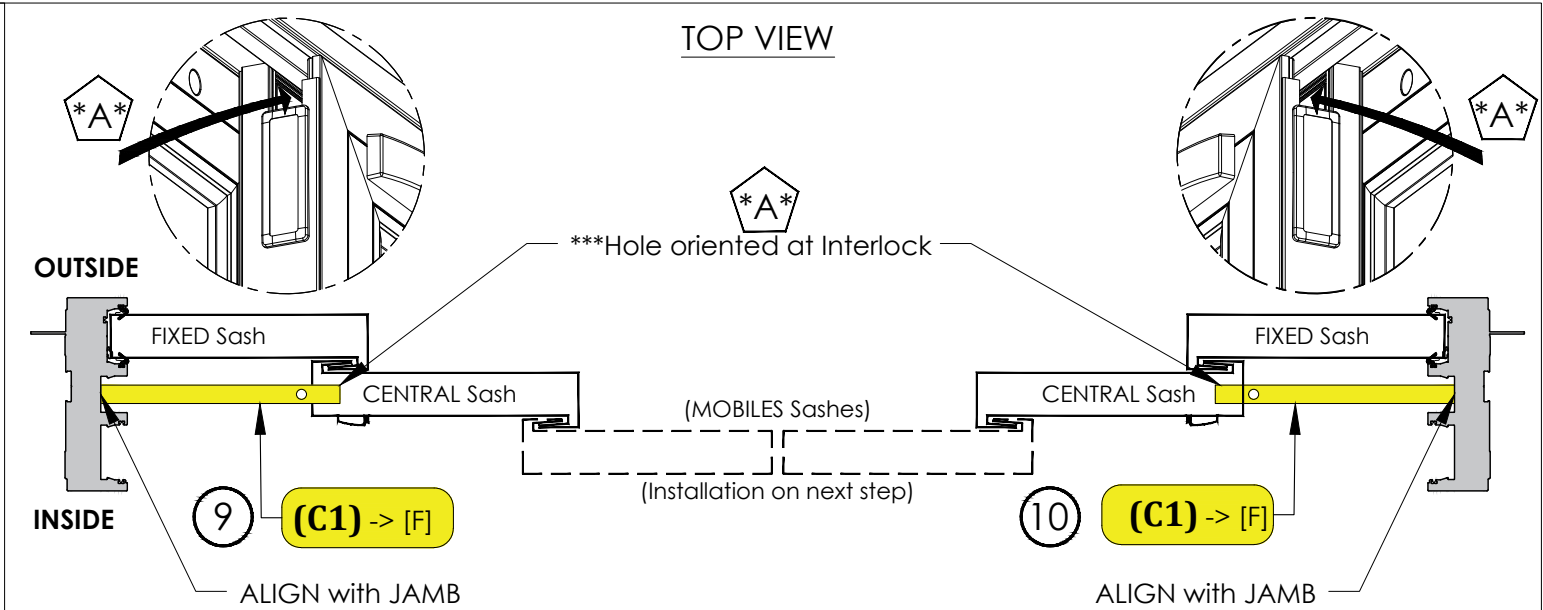





Installation of Mobile Sashes & Head Tracks #8321

\*Tools and components required for this step\*

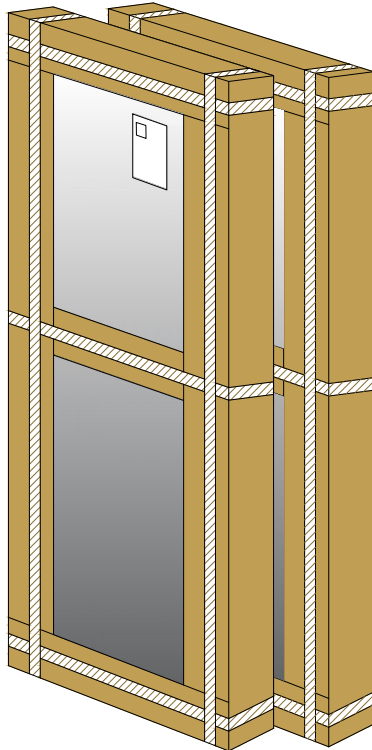

Mobile Sash Box  
(2X)

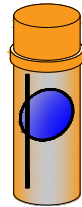

Invisible Lubricant  
Silicone  
(1X)

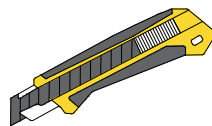

Knife  
(1X)

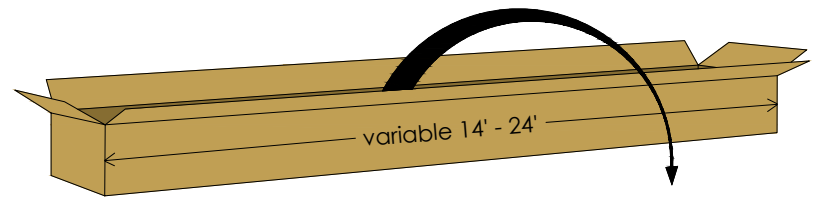

8321  
(3X)

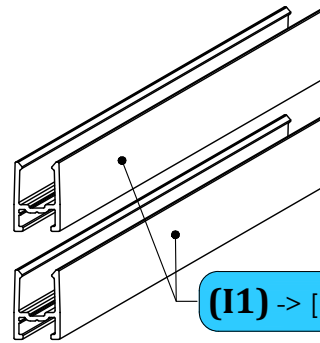

**(I1)** -> [F]

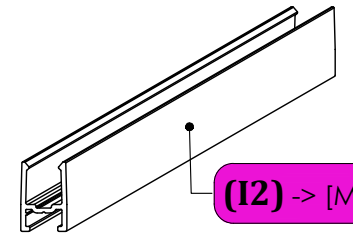

**(I2)** -> [M]

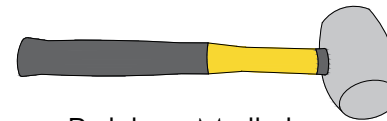

Rubber Mallet  
(1X)



STEP: **9**

(Continued) Installation of Mobile Sashes & Head Tracks #8321

REVISION: 2020/05/28

PAGE: P31

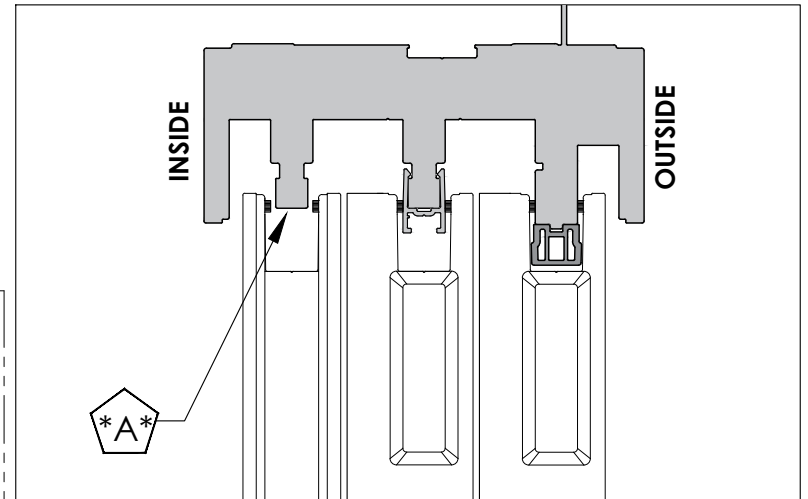
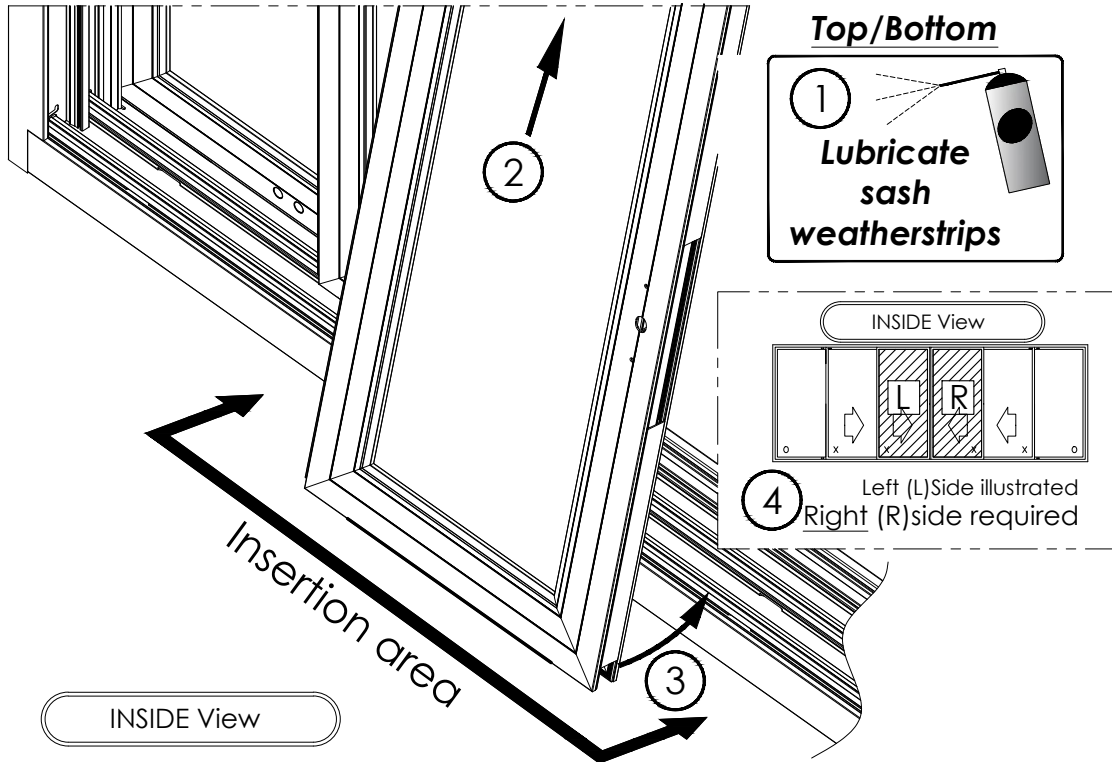

**IMPORTANT:** Sash header engagement is minimal at this stage. (The sash is free standing and could disengage from the header until head track is installed (see next page).

\*A\*

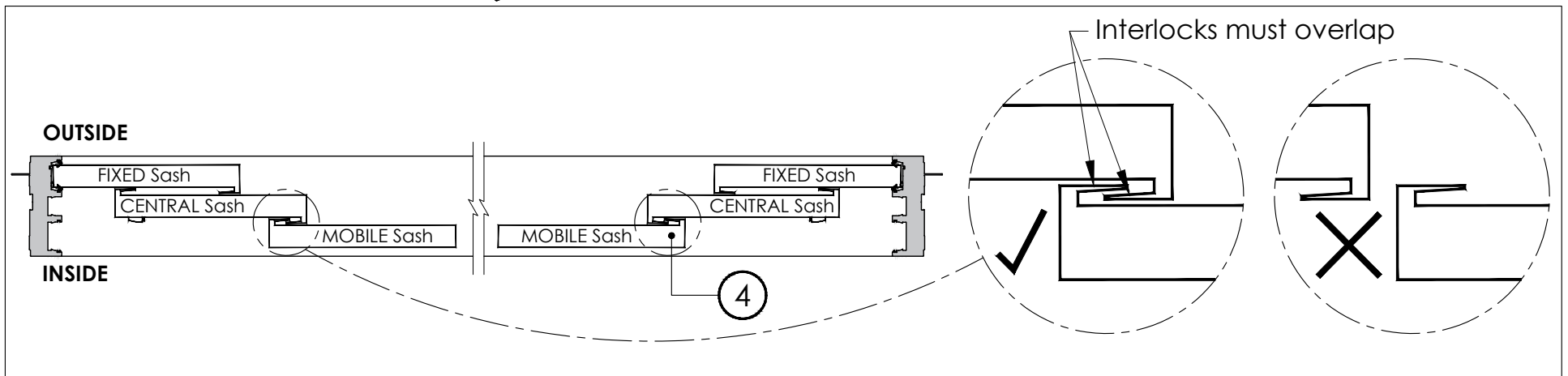



(Continued) Installation of Mobiles Sashes & Head Tracks #8321

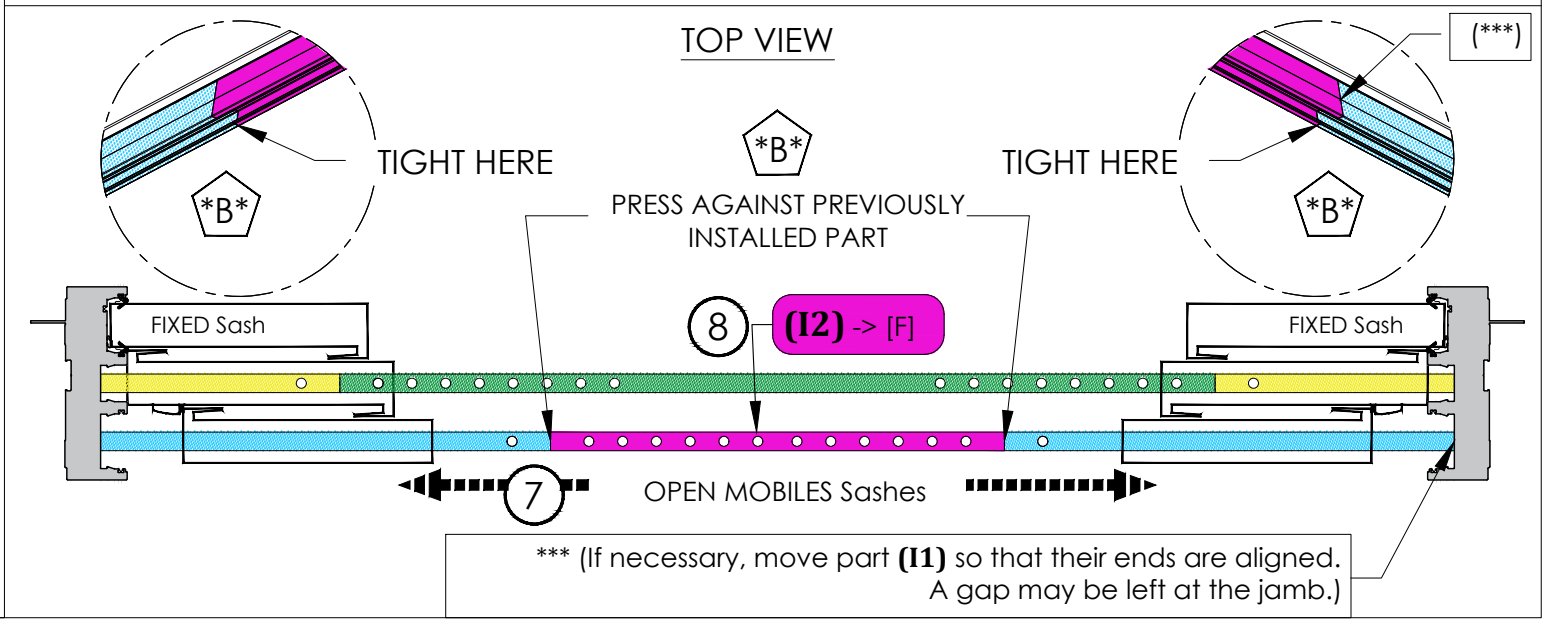
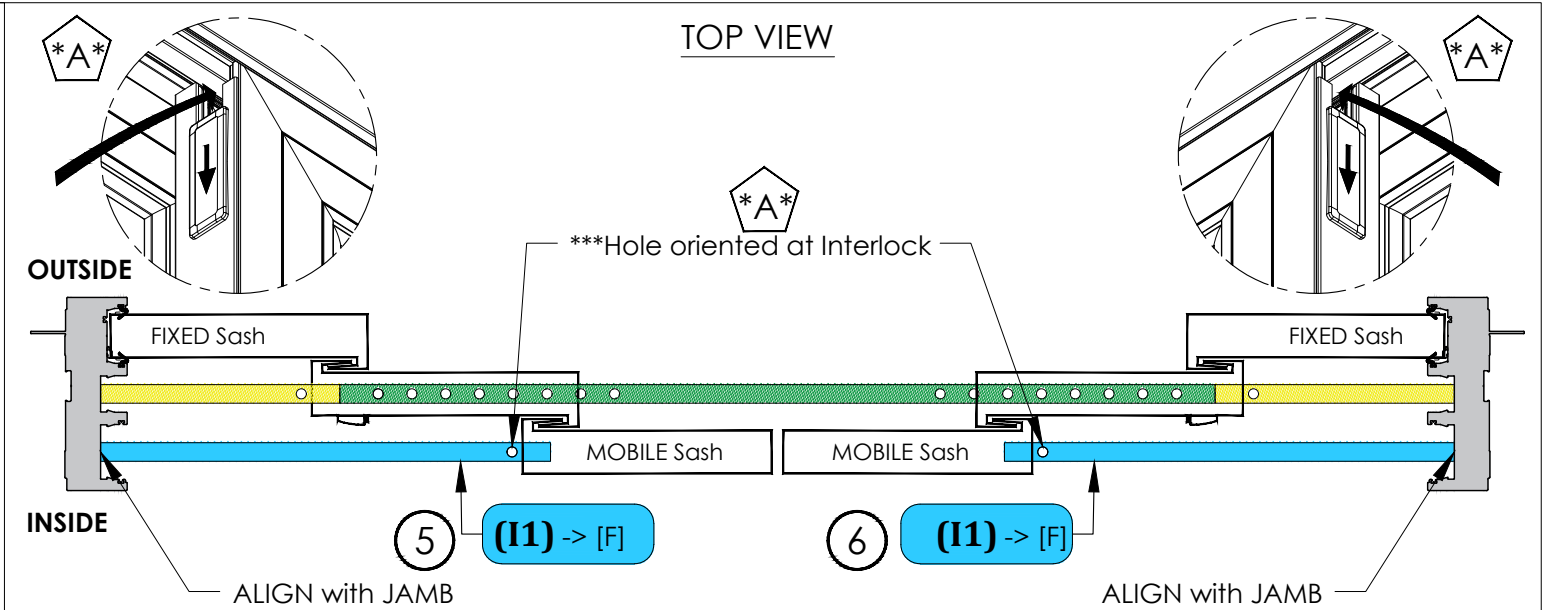
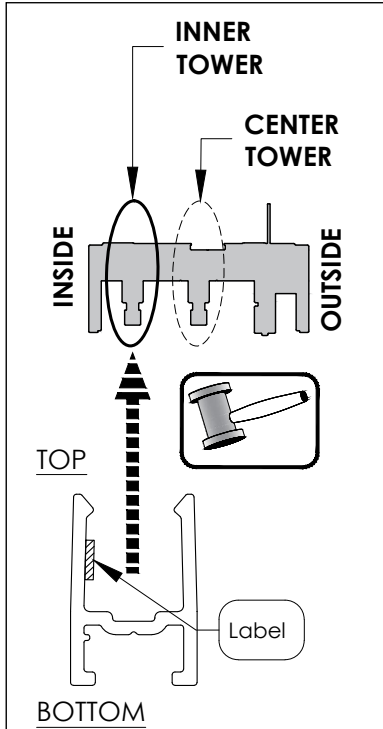

**Legend:**

**INNER TOWER:**  
**(I1) -> [F]**  
 = Part 1 (close to Fixed Sash)

**(I2) -> [M]**  
 = Part 2 (close to Mobile Sash)

**CENTER TOWER:**  
**(C1) -> [F]**  
 = Part 1 (close to Fixed Sash)

**(C2) -> [M]**  
 = Part 2 (close to Mobile Sash))



STEP:  
**10**

# Adjustment of Sashes

REVISION:  
2020/05/28

PAGE:  
P33

\*\*\*OUTSIDE View\*\*\*

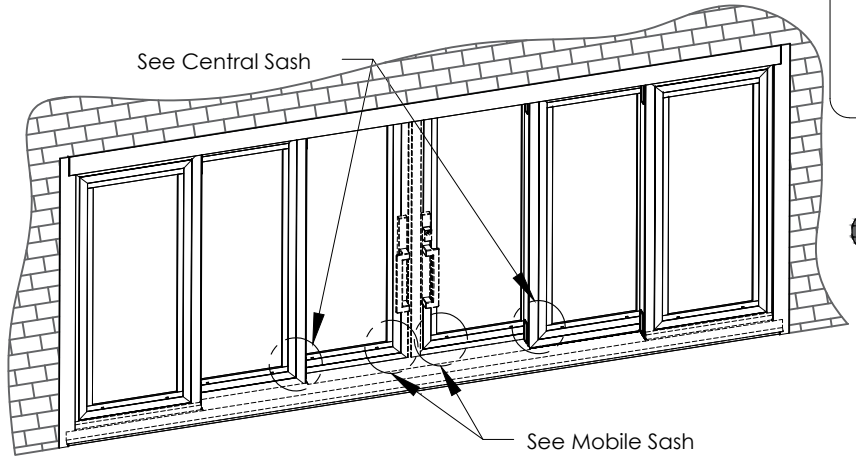

See Central Sash

See Mobile Sash

**ATTENTION:**  
Adjust the height and squareness of the sashes (centrals and mobiles) with the adjusting screw.



Screwdriver Bit  
Quadrex 6" #2 (1X)

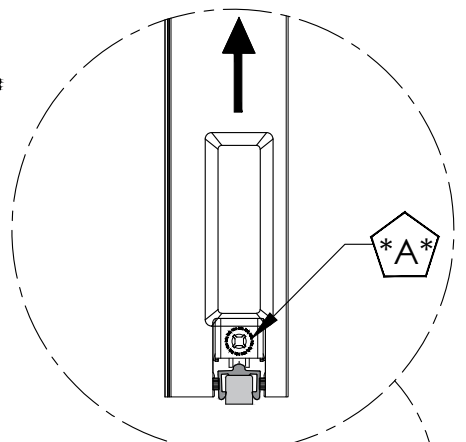

Mobile Sash

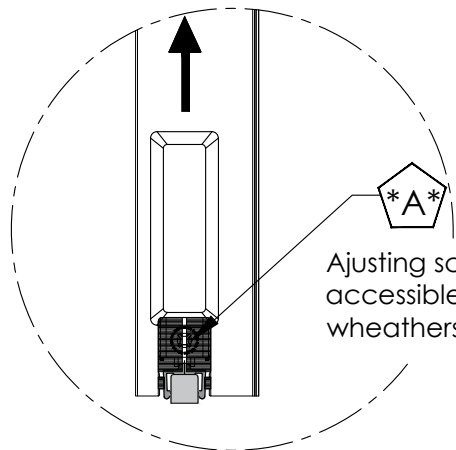

Ajusting screw accessible behind the weatherstrip

Central Sash

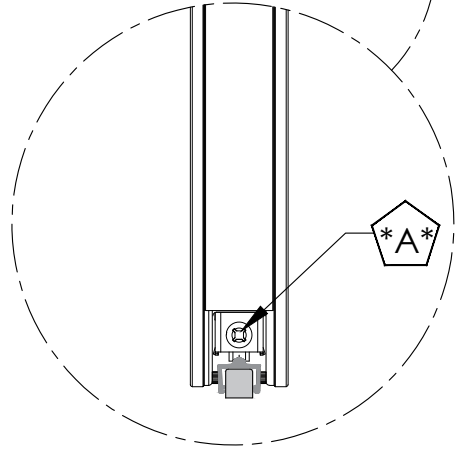

INSIDE View

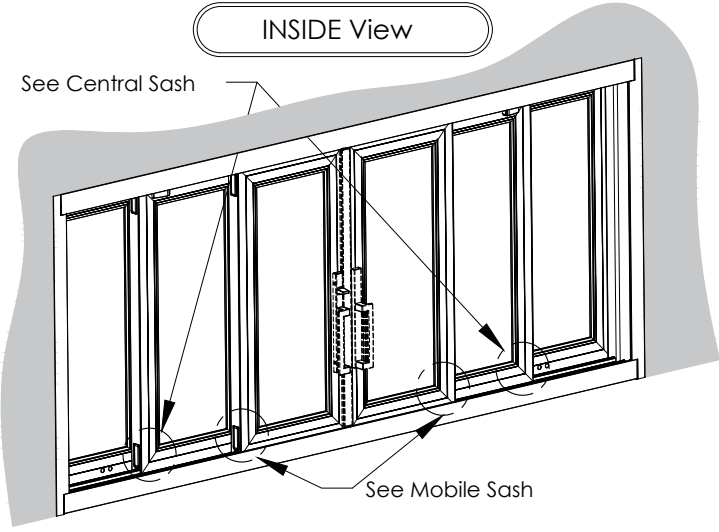

See Central Sash

See Mobile Sash



# Installation of Head Blocks

\*Tools and hardware required for this step\*



Impact  
(1X)

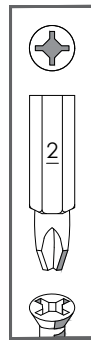

Screwdriver Bit  
(1X)

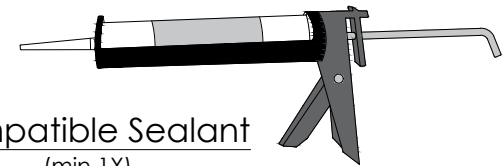

Compatible Sealant  
(min.1X)



Screwdriver Bit  
Quadrex 6" #2 (1X)

08380.00.SACn2.6V : HEAD Hardware bag

1-1/4" [32mm]

8941.VIS08  
(14X)  
\*BLACK\*

\*\*Assembled with foam 8373\*\*

00703.ADM35  
(5X)

8703.BMSCF  
(2X)



(Continued) Installation of Head Blocks

TOP VIEW

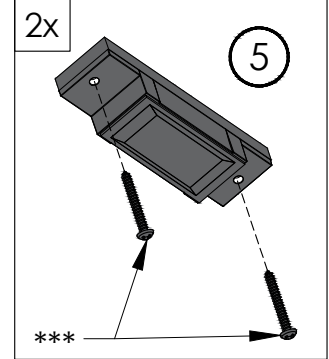
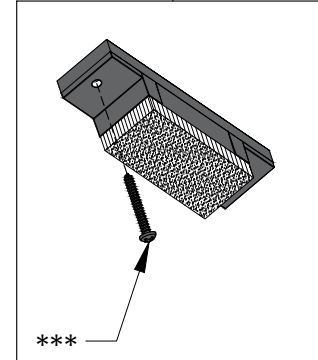
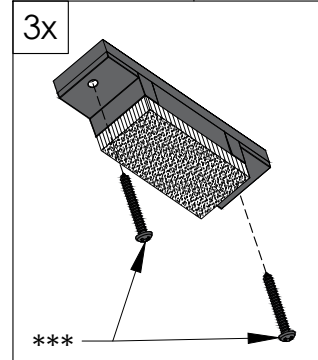
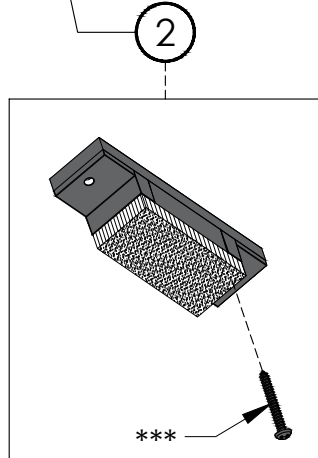
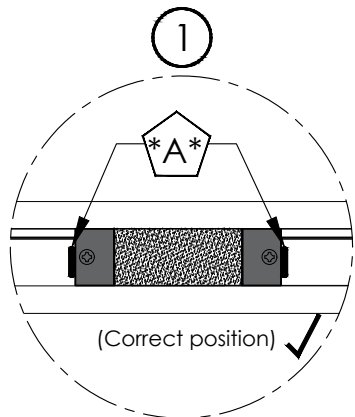
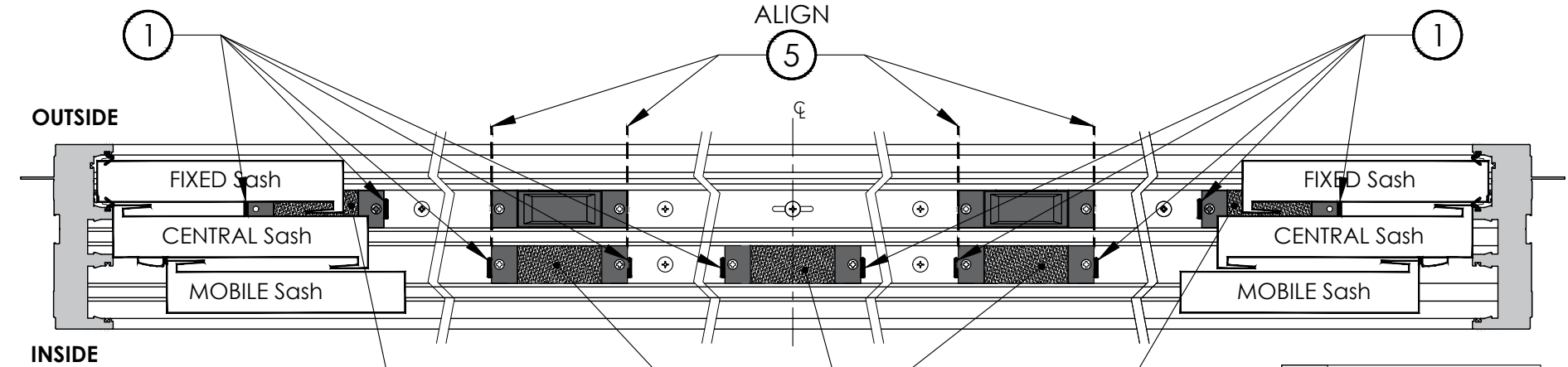

**ATTENTION:**  
 The blocks must be centered between the marks.

**\*\*\*ATTENTION\*\*\*:**  
 Do not overtighten screws  
 (Foam under head block should not be compressed)



(Continued) Installation of Head Blocks

TOP VIEW

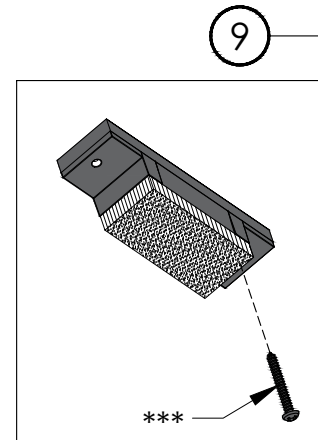
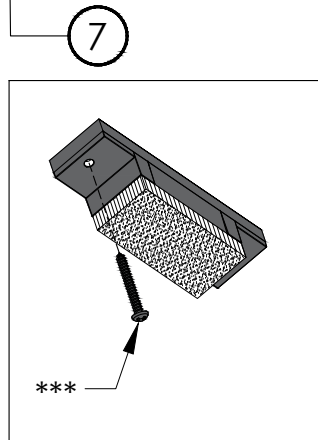
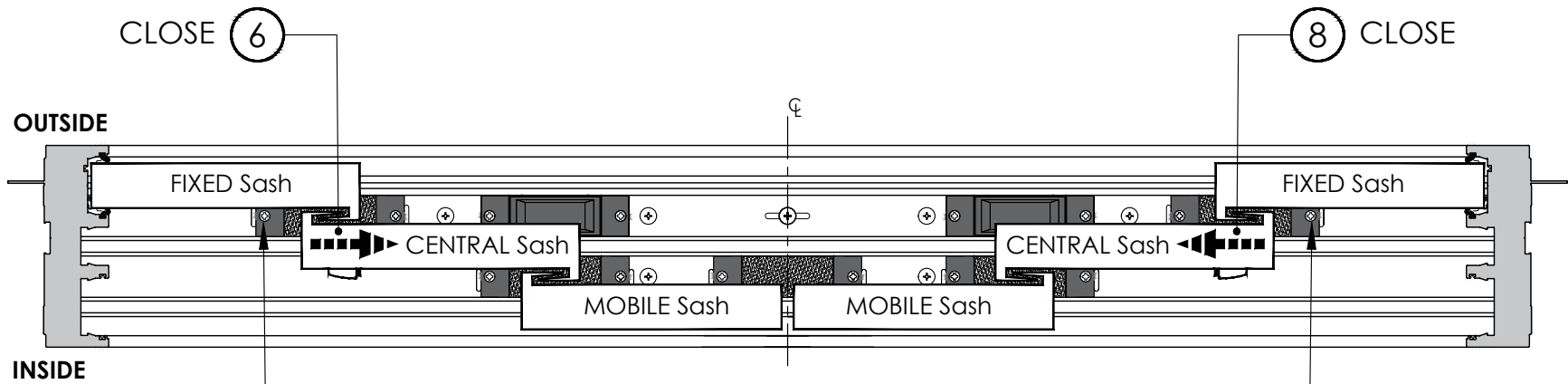

**\*\*\*ATTENTION\*\*\*:**  
**Do not overtighten screw**  
**(Foam under head block should not be compressed)**



STEP:  
**11**

(Continued) Installation of Head Blocks

REVISION:  
2020/05/28

PAGE:  
P37

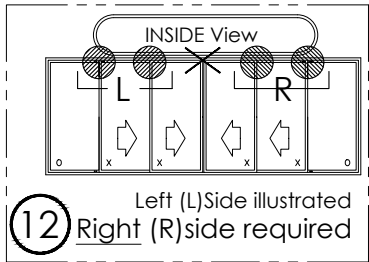

12 Left (L) Side illustrated  
Right (R) side required

**ATTENTION: On the outer face of the head blocks WITH Weatherstrip:**  
Make sure the grooves in the head are filled with sealant.  
(Not required for the block at center of door)

10 OPEN SASH

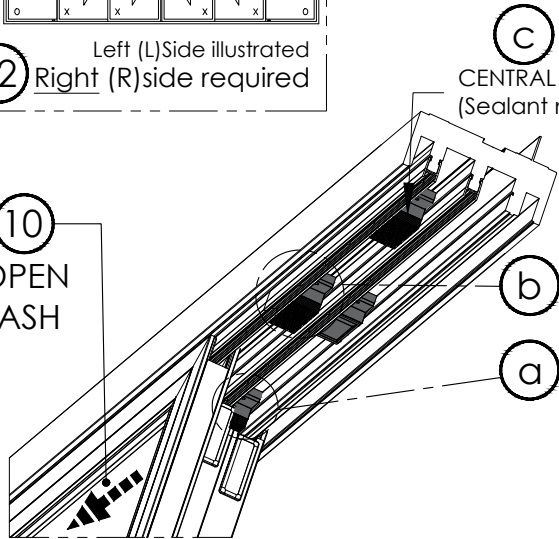

c CENTRAL BLOCK  
(Sealant not required)

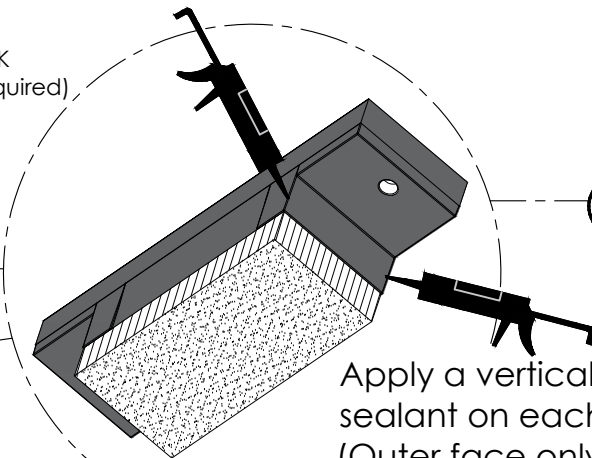

Apply a vertical bead of sealant on each edge.  
(Outer face only)

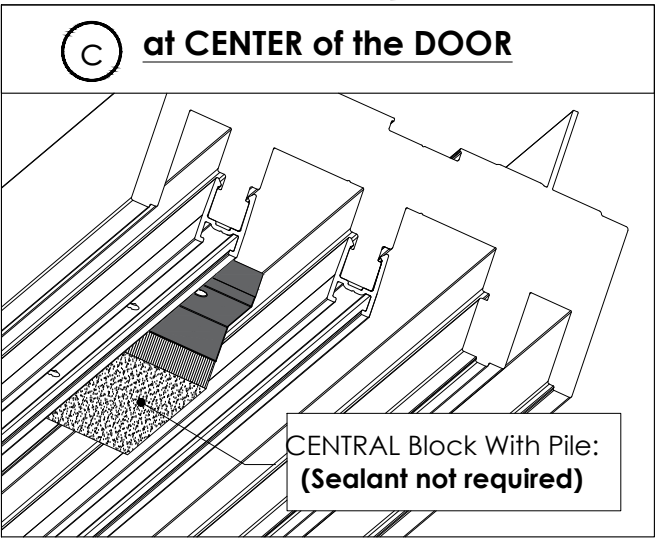
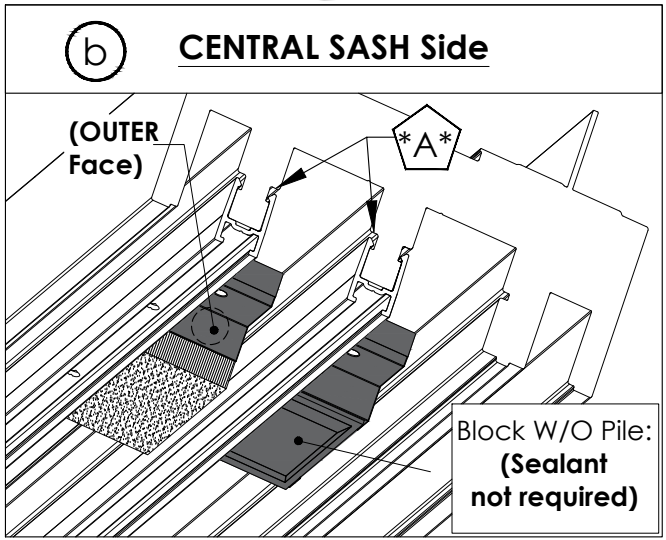
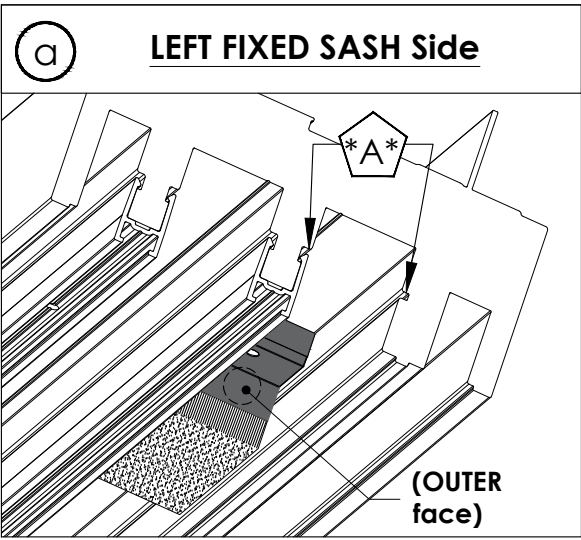
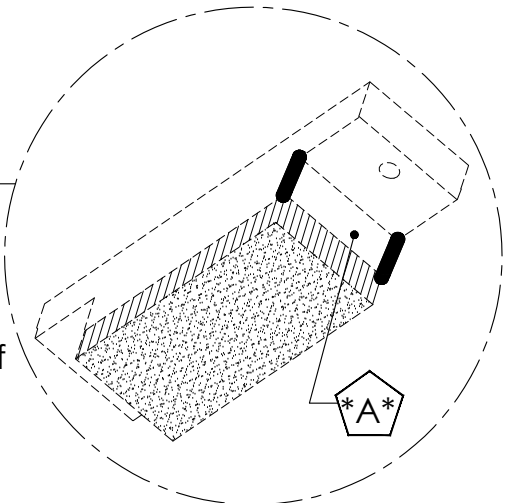





STEP: **12**

# Installation of Jamb Covers (Interior) & Sash Stops

REVISION: 2020/05/28

PAGE: P38

\*Tools and materials required for this step\*

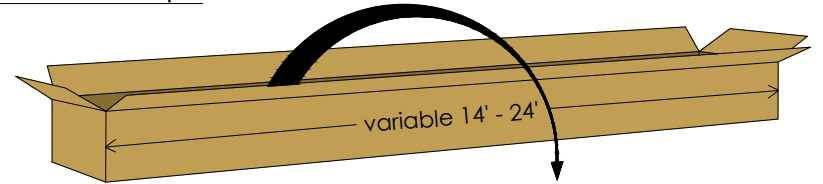
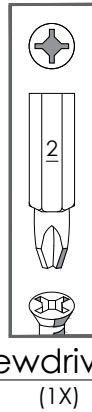
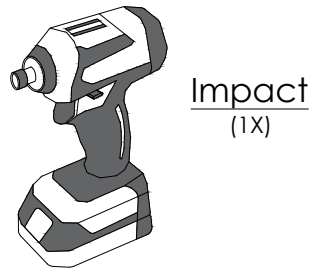
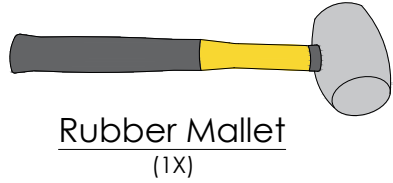

**08380.00.SACn2.6V** : HEAD Hardware bag

**8941.VIS08**  
(4X)  
**\*black\***

**8940**  
(2X)

**\*\*Assembled with shim 8789\*\***

1-1/4" [32mm]

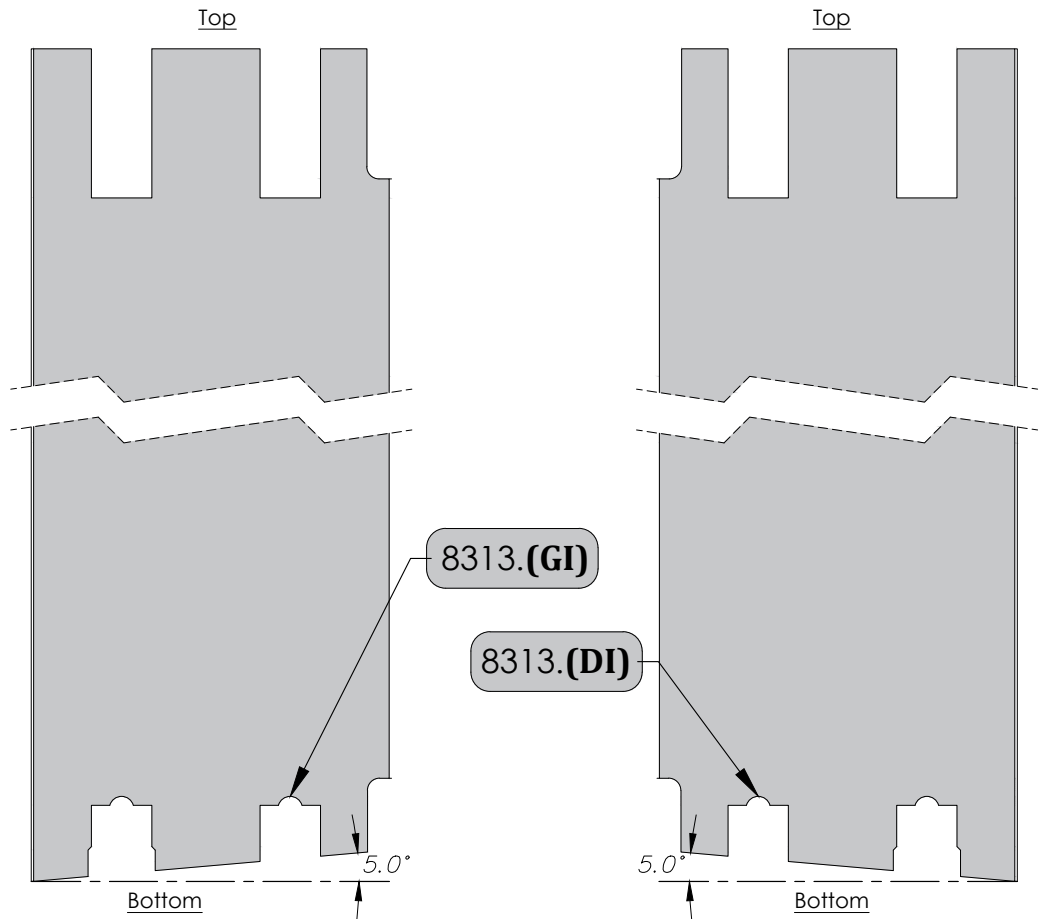



STEP: 12

(Continued) Installation of Jamb Cover (Interior) & Sash Stop

REVISION: 2020/05/28

PAGE: P39

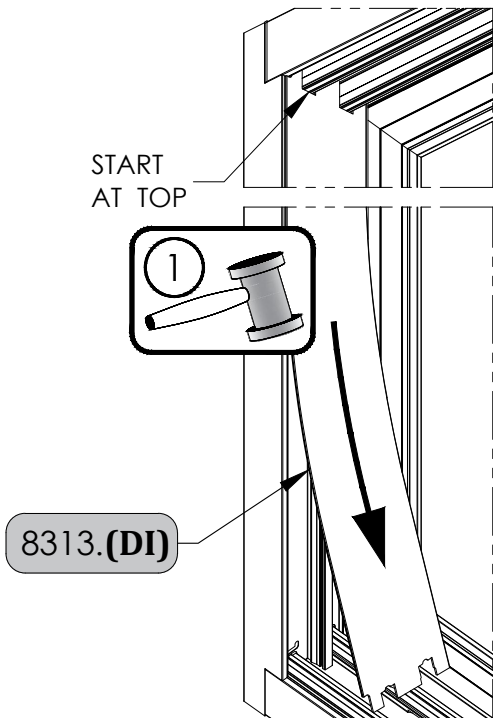
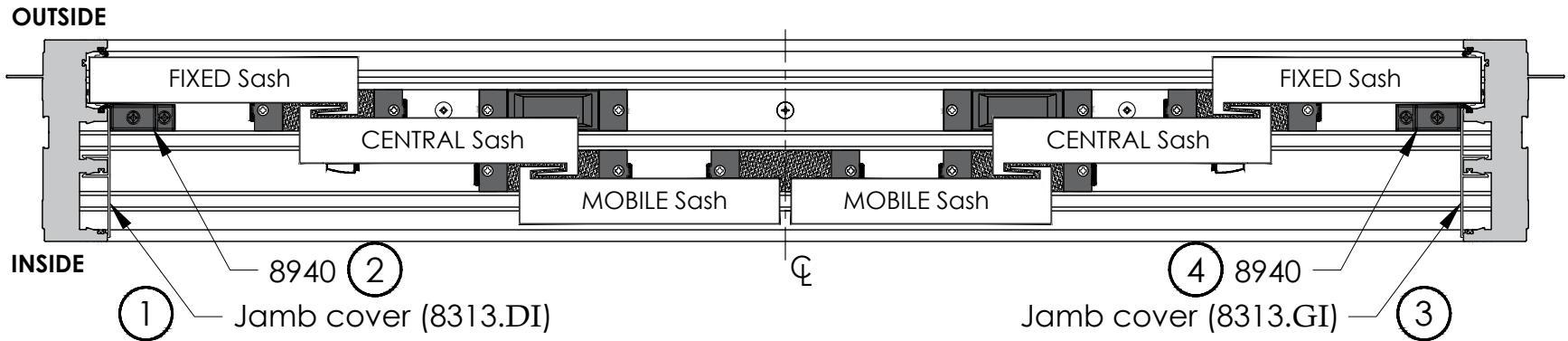

INSIDE View

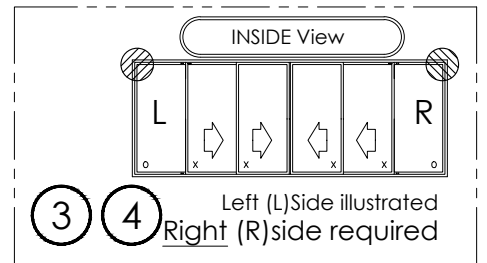
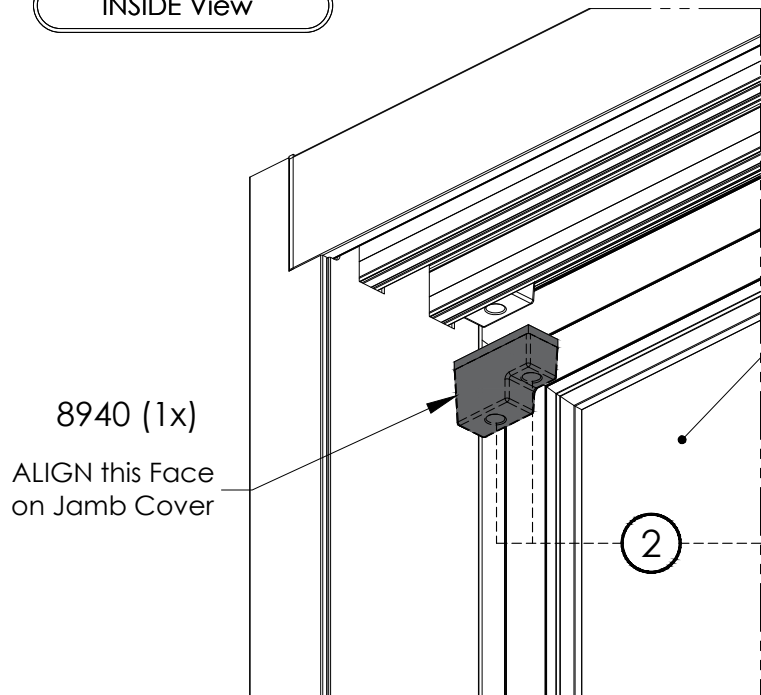

FIXED SASH

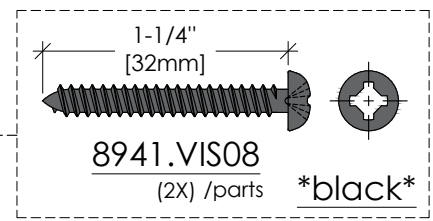



Installation of Head Covers #8323

\*Components required for this step\*

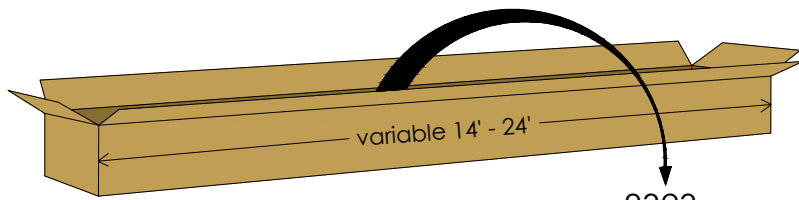

8323  
(9X)

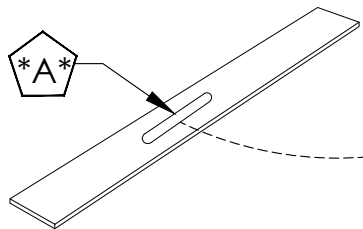

8323.(- -)



PAY ATTENTION TO THE COLOR IF THE DOOR IS PAINTED

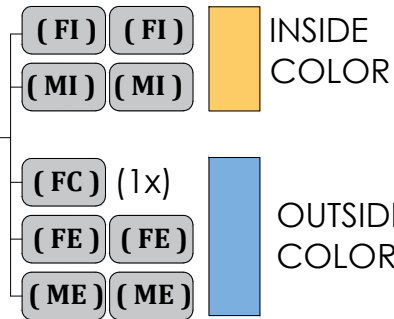

**ATTENTION:**  
Label should not be visible  
when part is installed.  
(See next page)

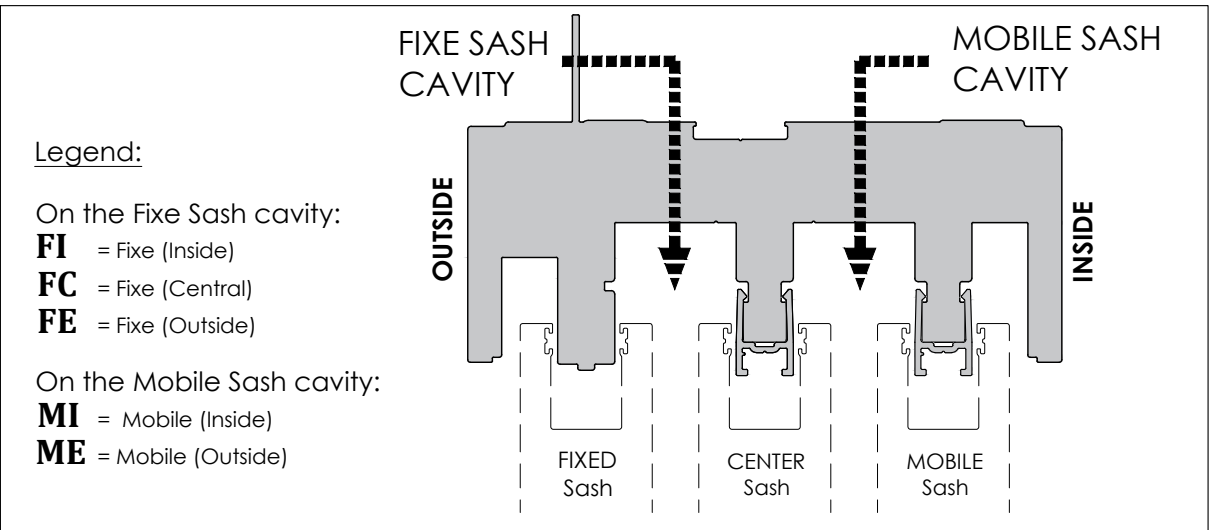

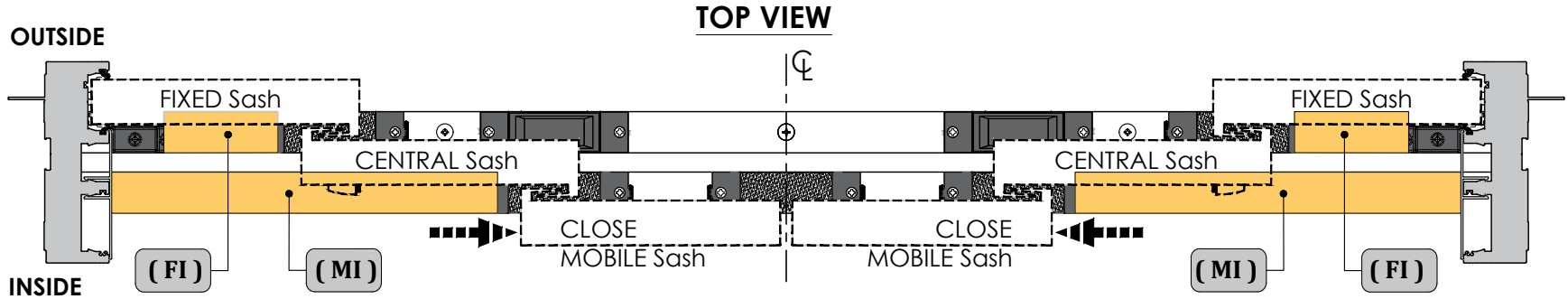

\*A\*

**Follow steps (1-2-3) for each head covers.  
Make sure the parts are properly snapped.  
\*(Pay attention at the color if door is painted)**

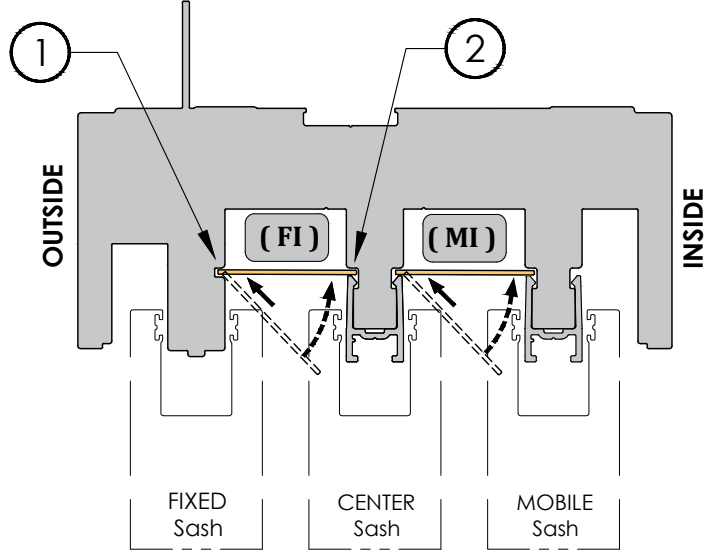
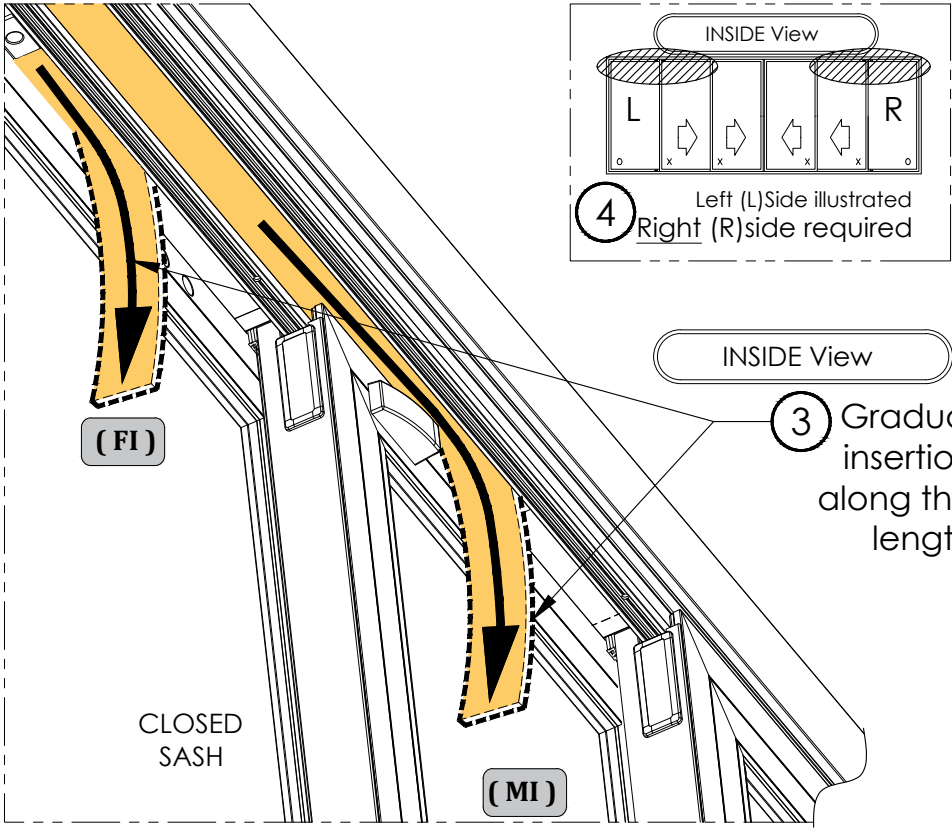



**TOP VIEW**

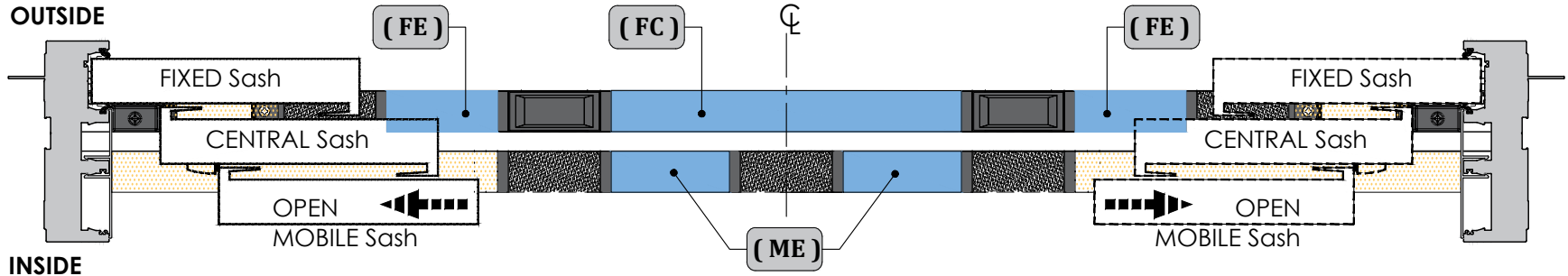

**\*A\***

**Follow steps (5-6-7) for each head covers. Make sure the parts are properly snapped. \*(Pay attention at the color if door is painted)**

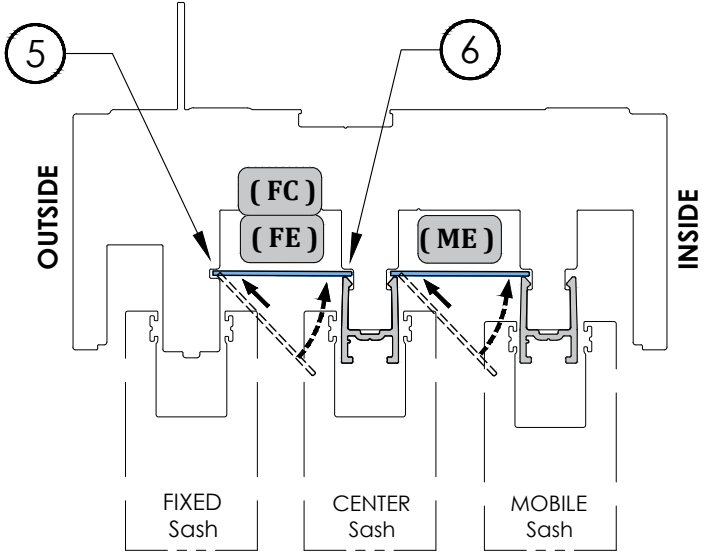
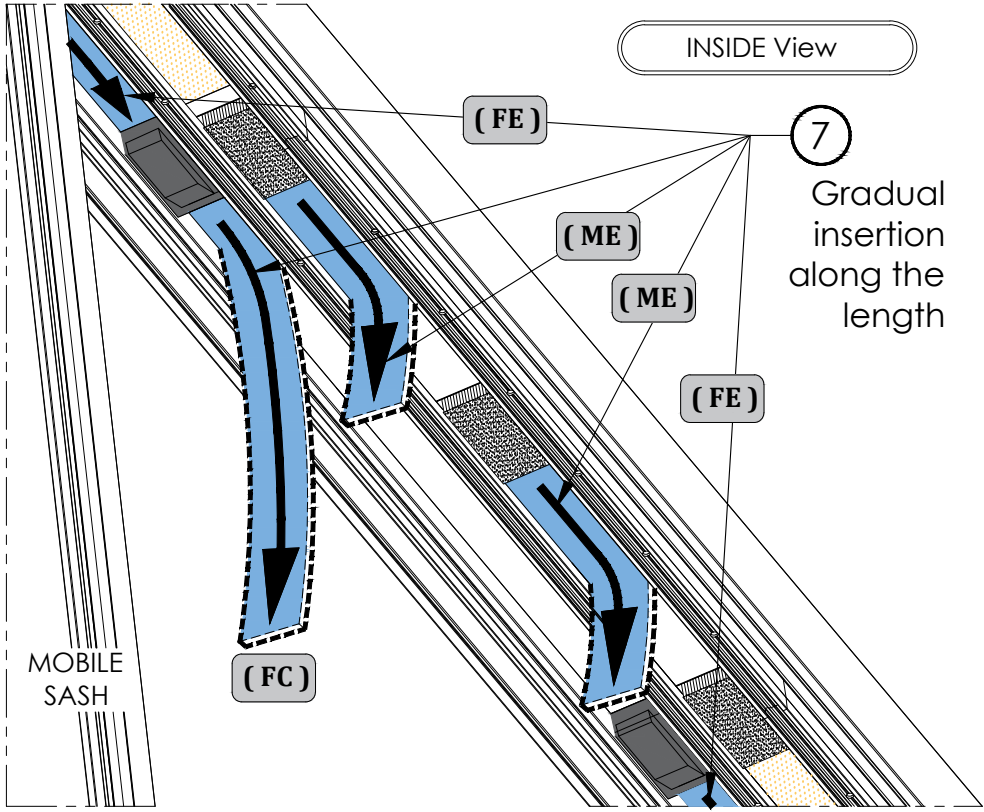



STEP:  
**14**

**Fastening Head Tracks #8321 to the Frame**

REVISION:  
2020/05/28

PAGE:  
P43

\*Tools and hardware required for this step\*



Impact  
(1X)

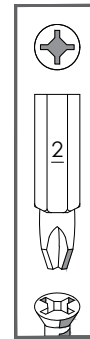

Screwdriver Bit  
(1X)

 08380.00.SACn2.6V : HEAD Hardware bag

---

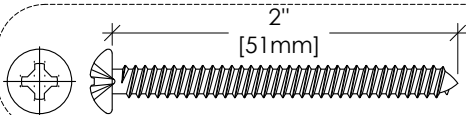
 2"  
[51mm]

8942.VIS10   
(32X)



(Continued) Fastening Head Tracks #8321 to the Frame

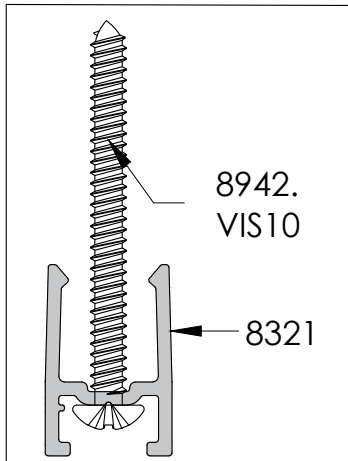
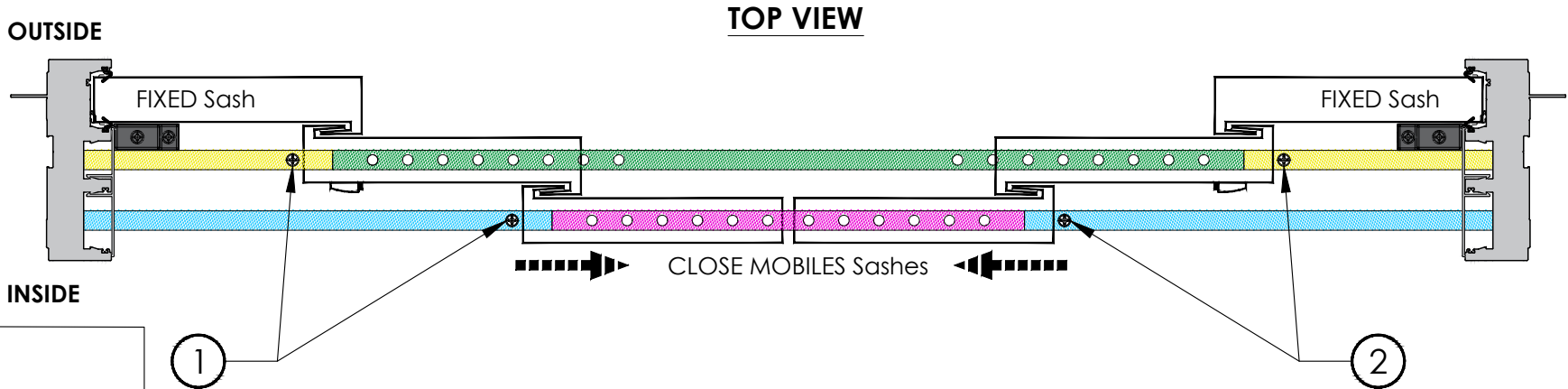

**ATTENTION : (CLOSED SASH & OPENED SASH)**  
 On each head tracks 8321, make sure that there is a screw in every visible holes.  
 \* Quantity of holes variable according to door width.

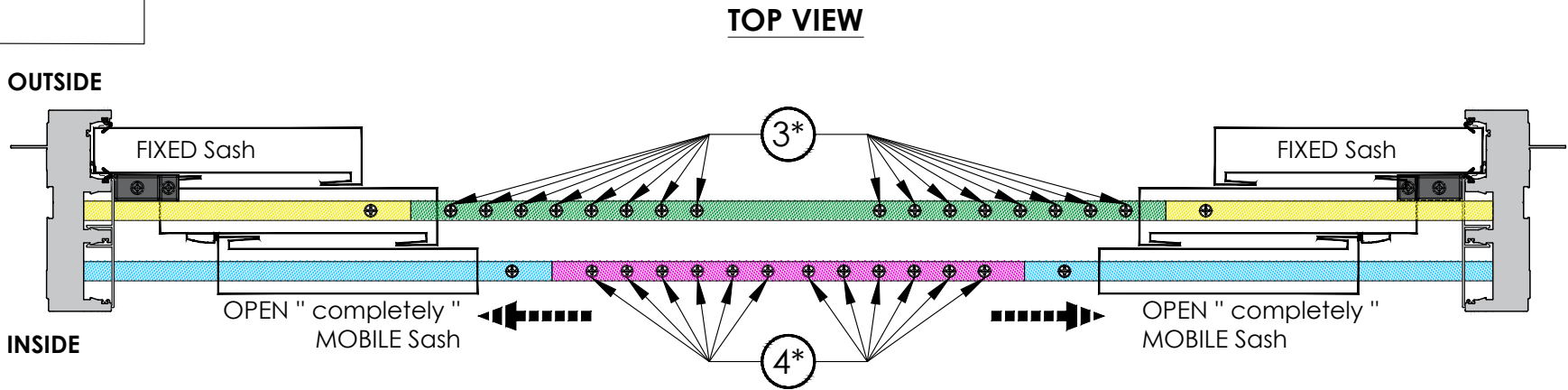



Installation of Groove Covers #8331

\*Tools and components required for this step\*

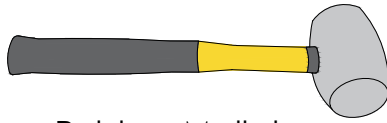

Rubber Mallet  
(1X)

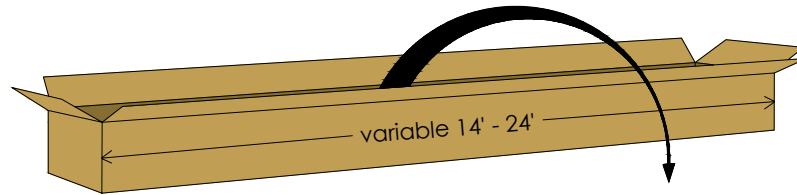

8331  
(5X)

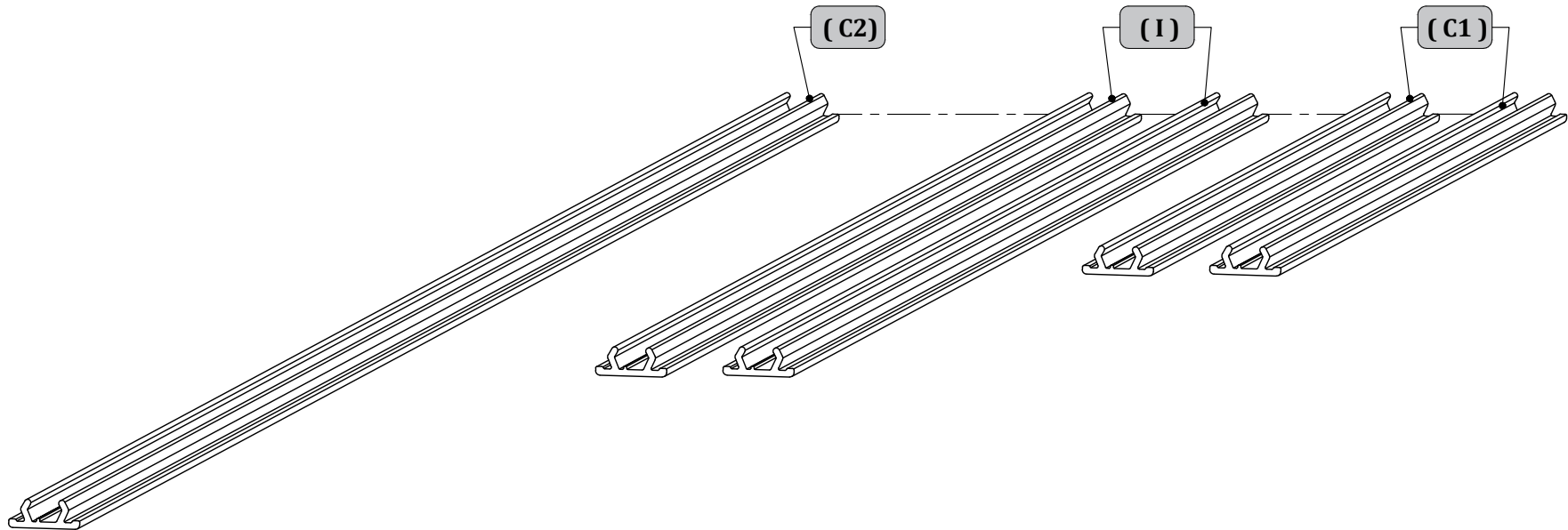





(Continued) Installation of Groove Covers #8331

**\* (If painted door)**

<b>* INSIDE COLOR</b>	(C1)
	(I)
<b>* OUTSIDE COLOR</b>	(C2)

**Legend:**  
**(I1)** = Inner tower  
**(C1)** = Central tower (Part 1)  
**(C2)** = Central tower (Part 2)

**INSIDE View**

**1** INSERT INTO SASH INTERLOCK

**2** INSERT INTO JAMB COVER

**3** ON FULL LENGTH (VISIBLE PART)

**4** Left (L) Side illustrated Right (R) side required

\*\*\* Insert the excess length through the Mobile sash until you reach the center of the door.



STEP:  
**15**

(Continued) Installation of Groove Covers #8331

REVISION:  
2020/05/28

PAGE:  
P47

**INNER TOWER**  
**CENTER TOWER**  
**INSIDE**  
**OUTSIDE**

Label

\* (If painted door)

	(C1)
	(I)
	(C2)

\*OUTSIDECOLOR

Legend:  
(I1) = Inner tower  
(C1) = Central tower (Part 1)  
(C2) = Central tower (Part 2)

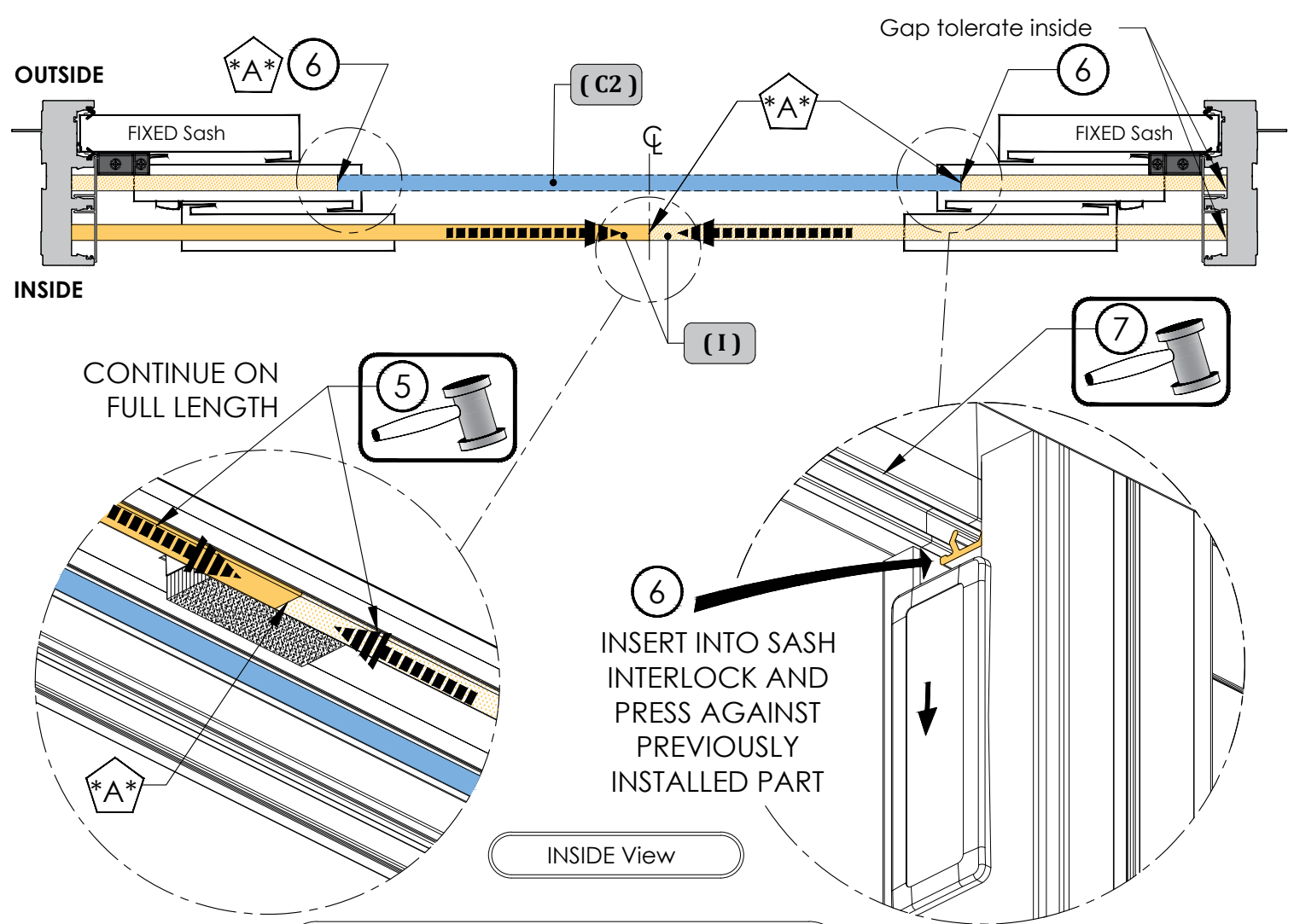

**6**  
INSERT INTO SASH INTERLOCK AND PRESS AGAINST PREVIOUSLY INSTALLED PART

**\*A\***  
**ATTENTION:**  
Make sure the joint between the parts is closed (Parts are tight).



Installation of Astragal

\*Tools and hardware required for this step\*



Impact  
(1X)

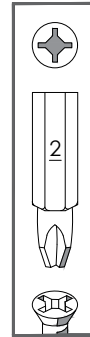

Screwdriver Bits  
(1X)



08375.58.SAAST.6V : Astragal Installation bag

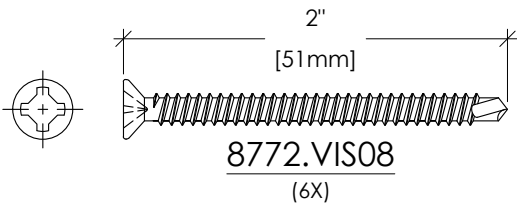

\*If painted door (OUTSIDE & INSIDE), rather use parts on red bag in Sill box.\*

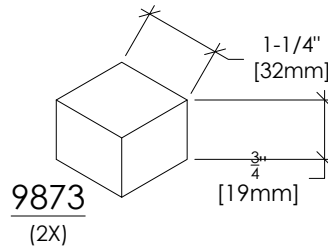
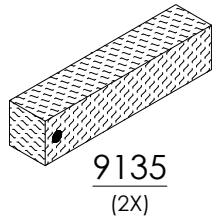
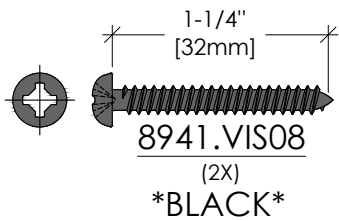



Installation of Astragal

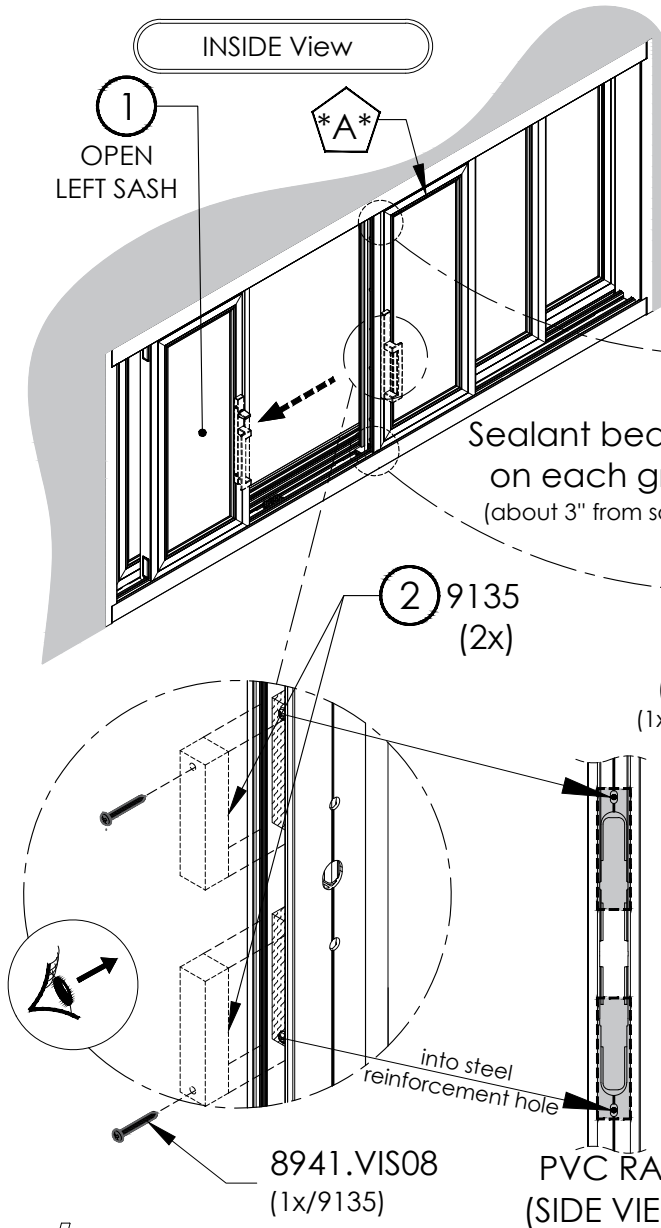

**\*A\*** **ATTENTION: (Viewed from Inside)**  
**Always install 8326 astragal**  
**only on RIGHT Mobile Sash.**  
**(Make sure the proper cut-out is at bottom).**

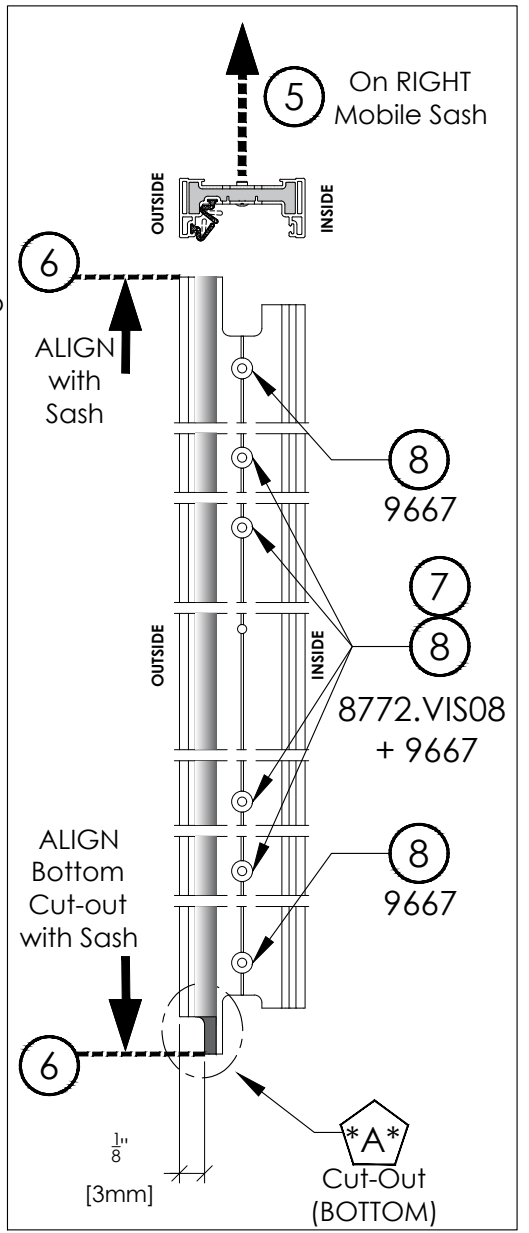
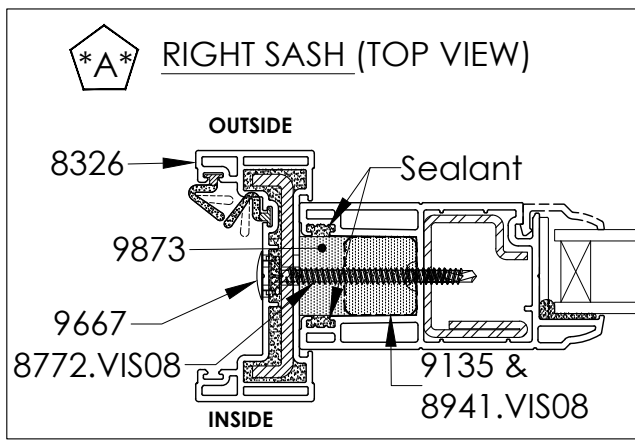
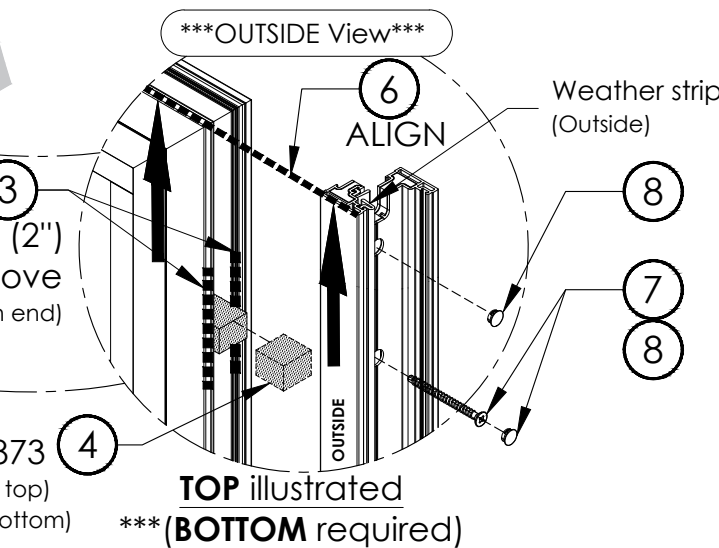



Installation of Handles, Lock & Keeper

REVISION:  
2020/05/28

PAGE:  
P50

\*Tools and hardware required for this step\*

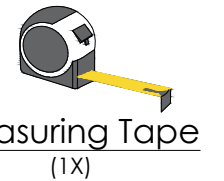
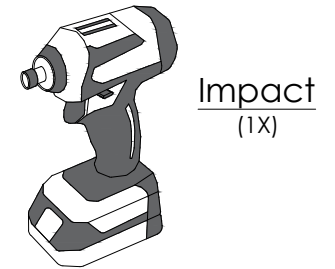
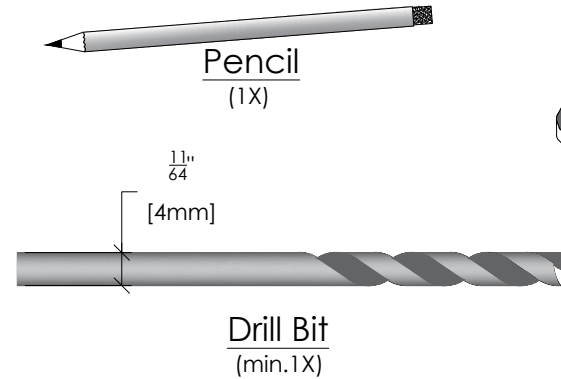
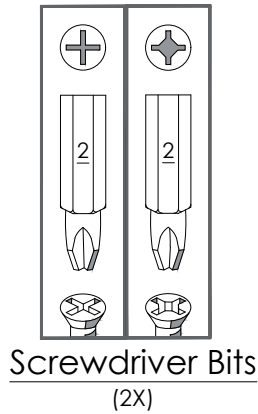
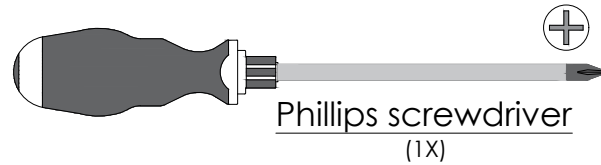
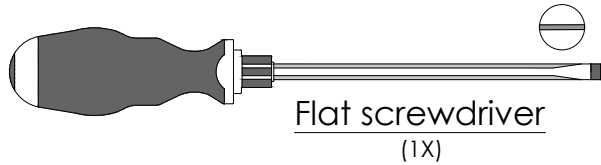

09250.KT.ENS2P : Lock & Keeper bag

9250.SER2P  
(1X)

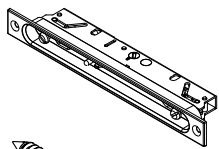

Screw  
#10 x 2-1/2"  
(2X)

*\* Not required \**

9149.VISME  
(#10 x 3/4")  
(2X)

9250.GACHE  
(1X)

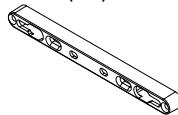

9250.VISGA  
(#10 x 1-3/4")  
(4X)

08375.58.SACn3.6V :  
FINISHED Hardware bag

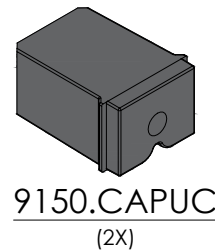

Handle  
(1X)

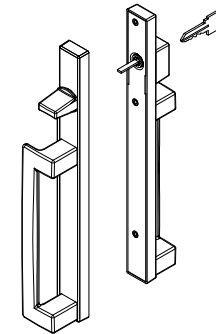

Dummy Handle  
(1X)

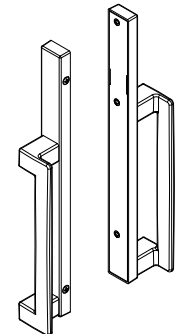

(model may differ of illustration)



(Continued) Installation of Handles, Lock & Keeper

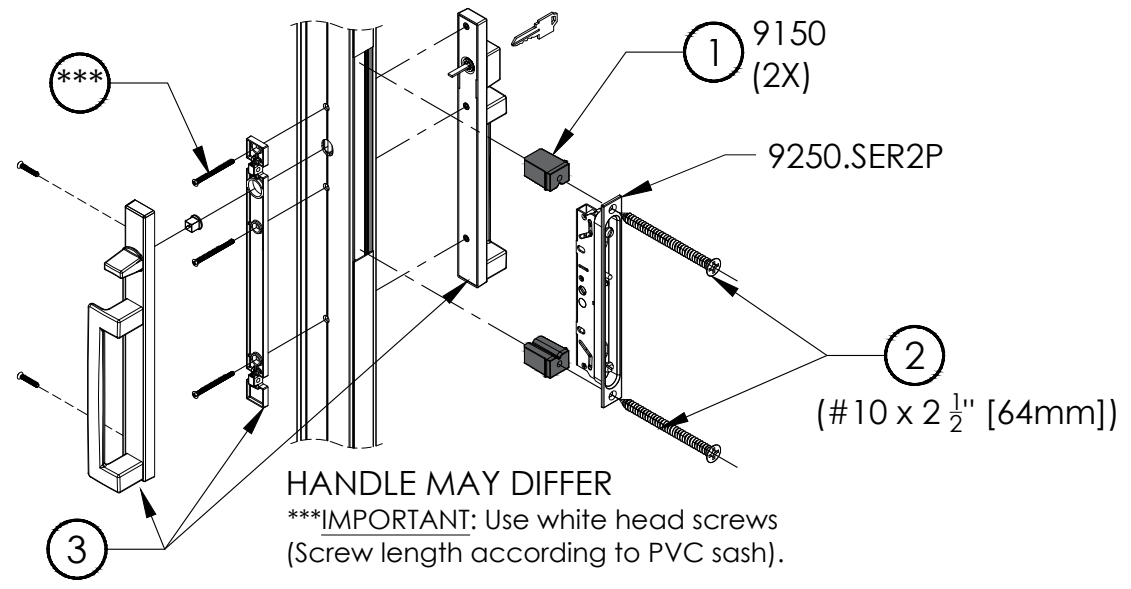
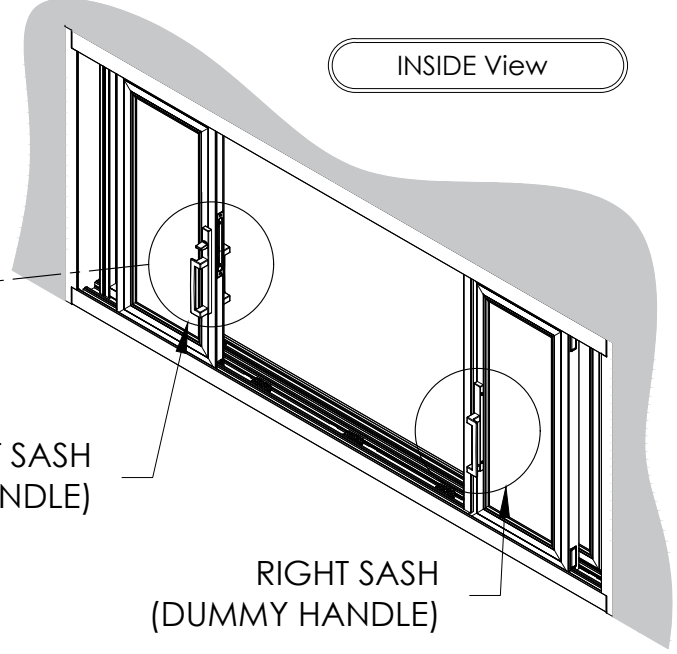
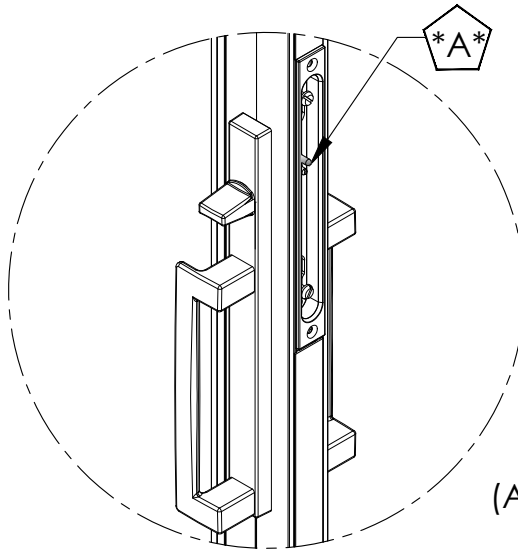
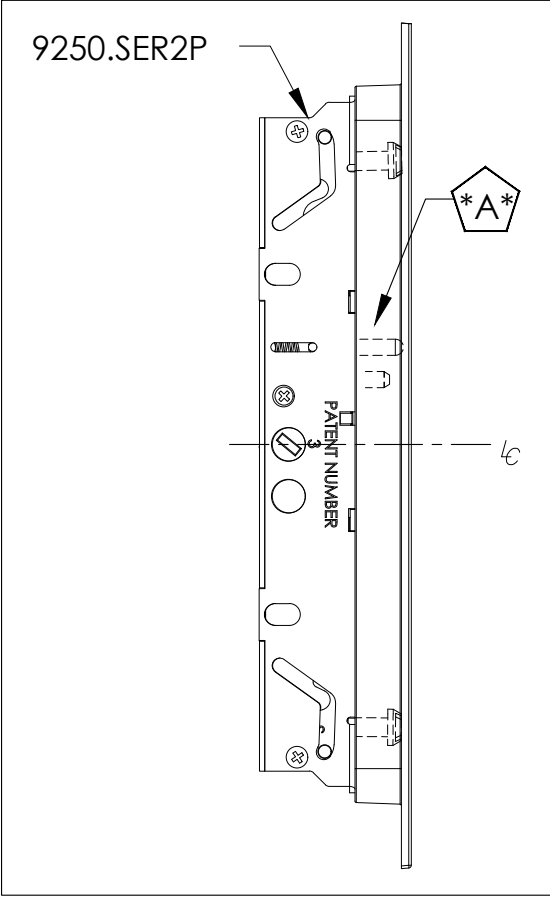
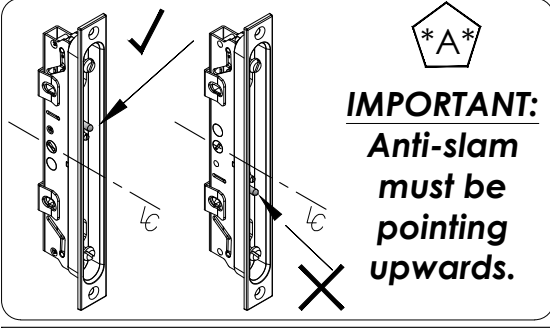



(Continued) Installation of Handles, Lock & Keeper

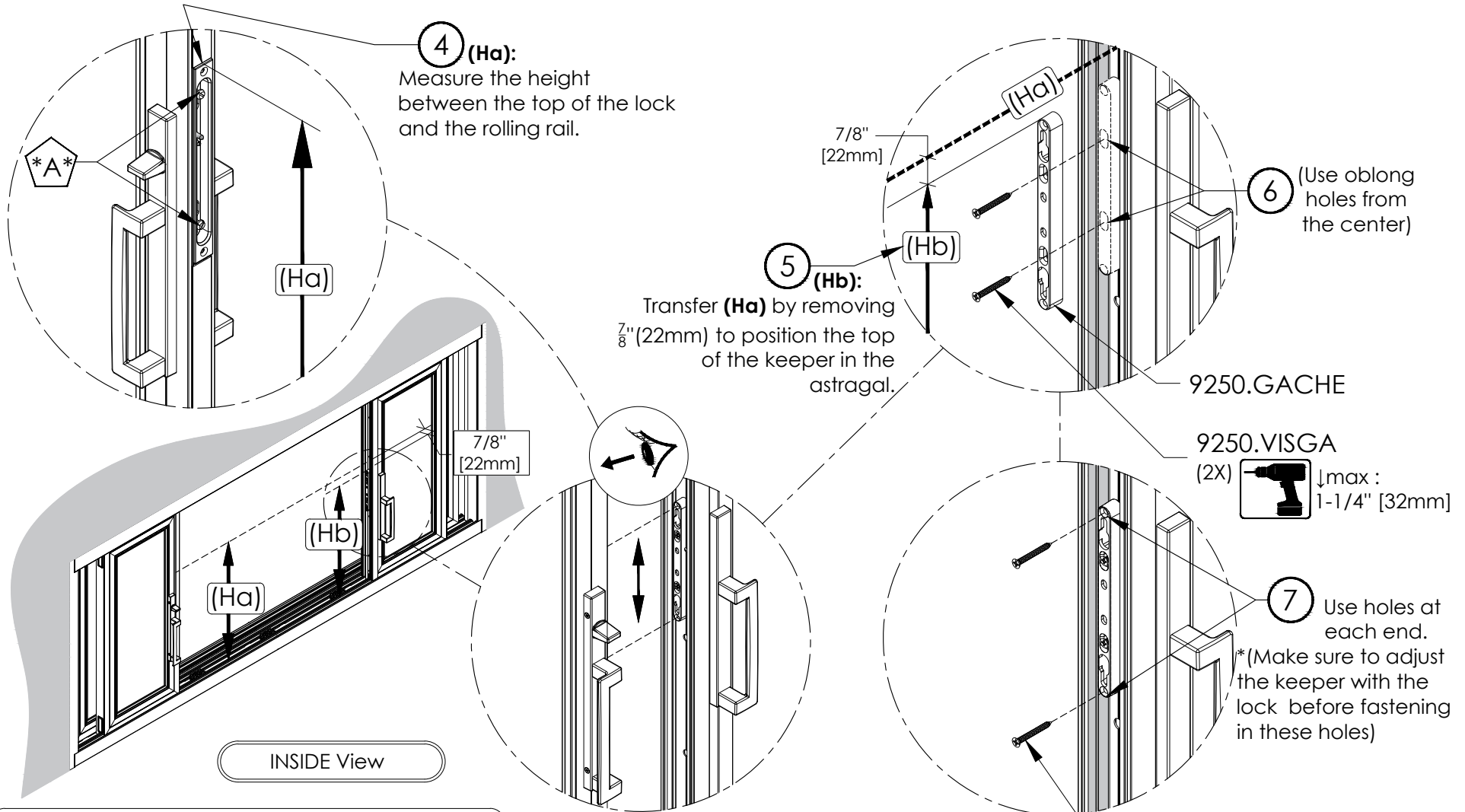

**ATTENTION:**  
Make sure to pre-drill holes before fastening keeper to the astragal.  
( $\varnothing \frac{11}{64}$ " x ↓1-1/4") [ $\varnothing 4.4\text{mm}$  x ↓32mm]



**IMPORTANT:** Adjust Lock if needed.



9250.VISGA (2X) ↓max : 1-1/4" [32mm]



STEP:  
**18**

# Installation of Drip Caps

REVISION:  
2020/05/28

PAGE:  
P53

\*Tools and components required for this step\*

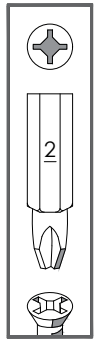

Screwdriver Bit  
(1X)



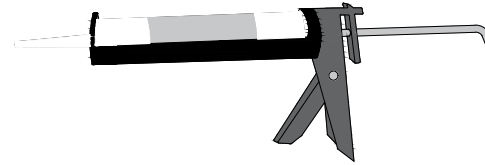

Impact  
(1X)

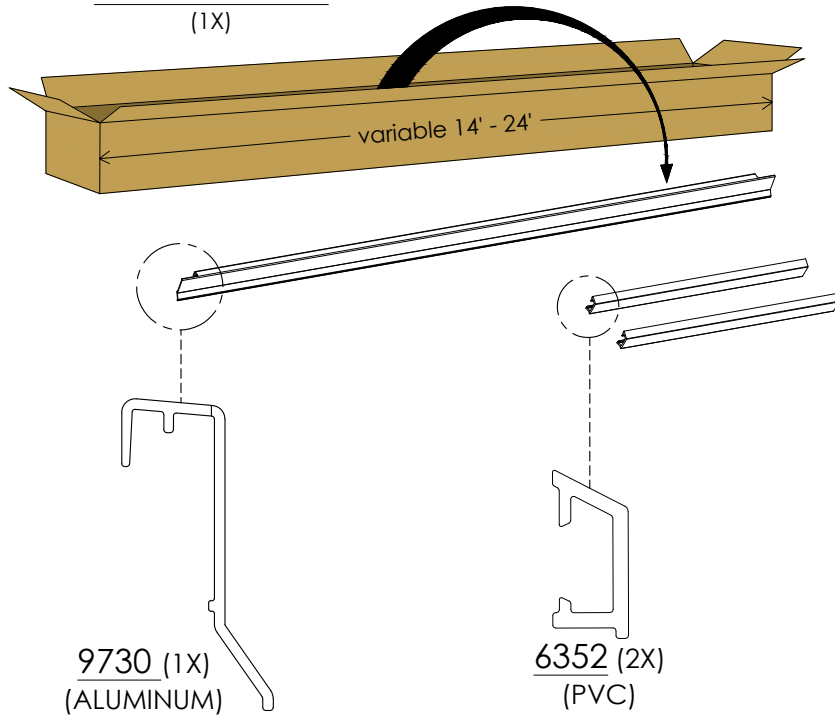

Compatible Sealant  
(min.1X)

  
\*If painted door (OUT=Outside), rather use parts on red bag in Sill box.\*

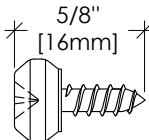

 08375.58.SACn3.6V : FINISHED Hardware bag

  
  
8813.VIS10  
(8X)

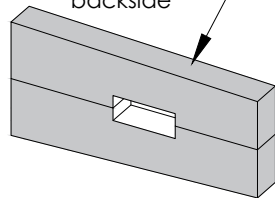
  
 Adhesive backside  
8377.GAPSF  
(1X)

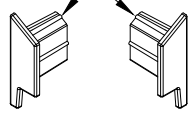
  
8395.58 CAPVS.G  
(1X)

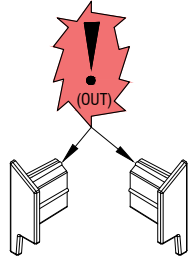
  
8395.58 CAPVS.D  
(1X)





(Continued) Installation of Drip Caps

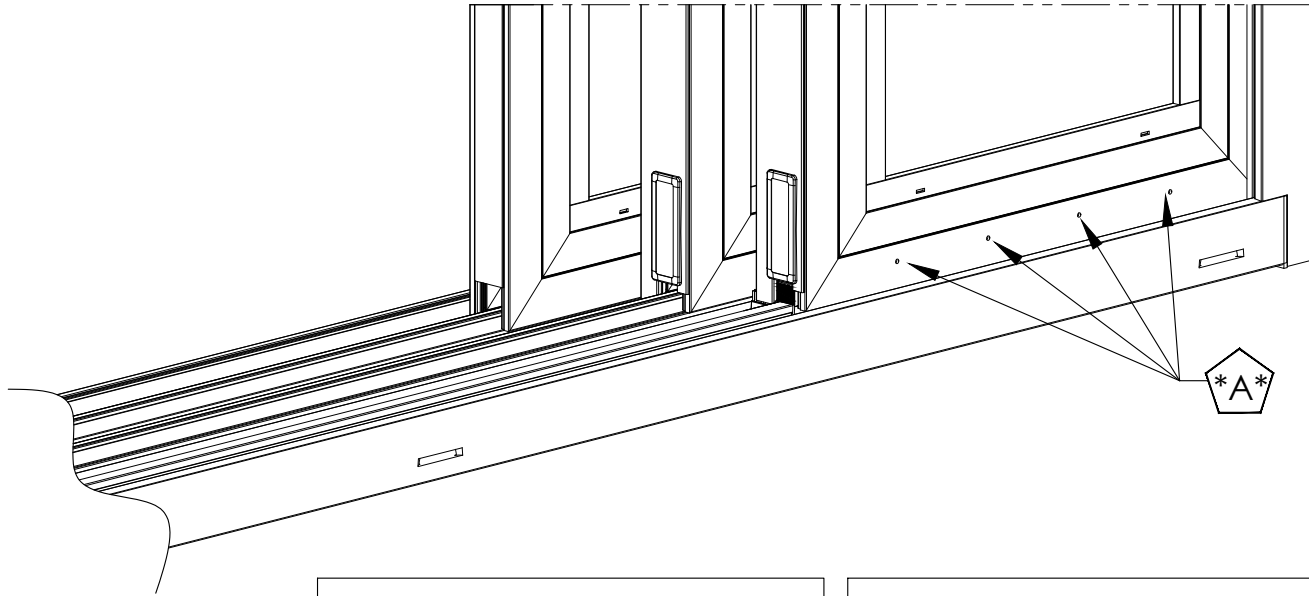

**IMPORTANT:**  
Install a screw in each hole after installing the 9730.

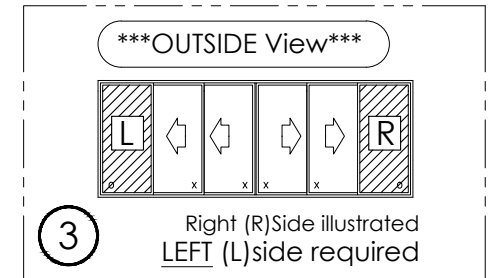
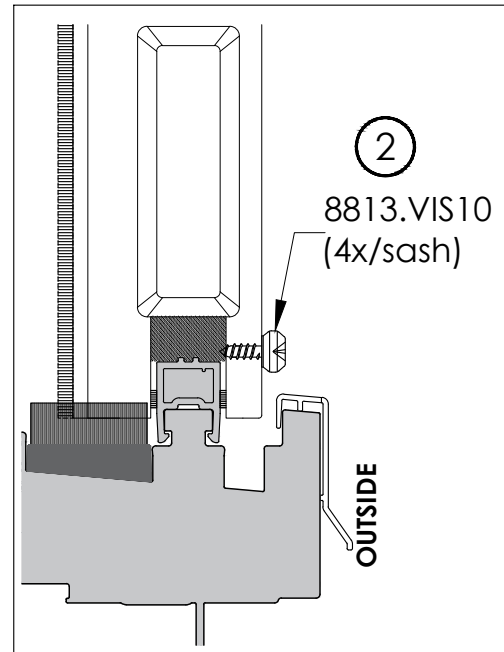
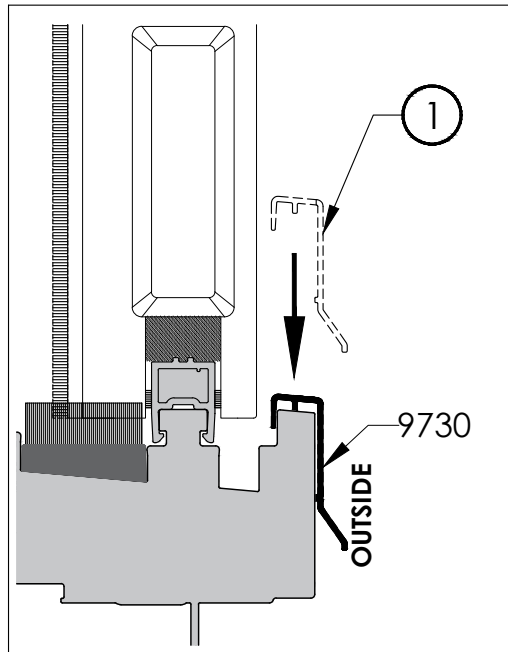



(Continued) Installation of Drip Caps

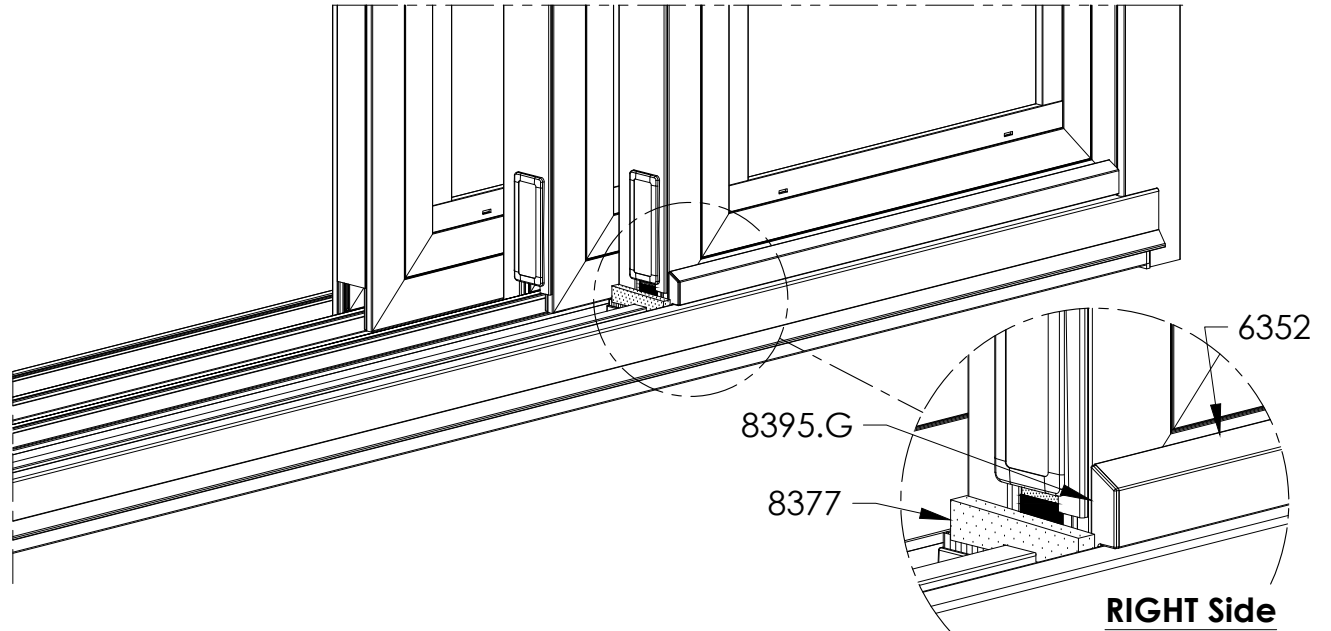
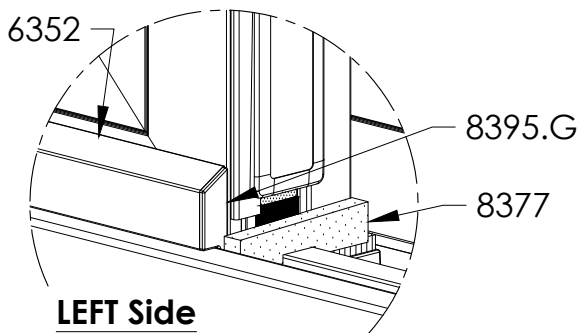
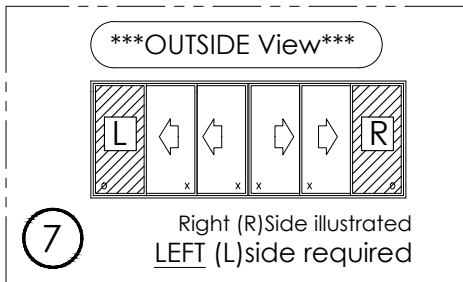
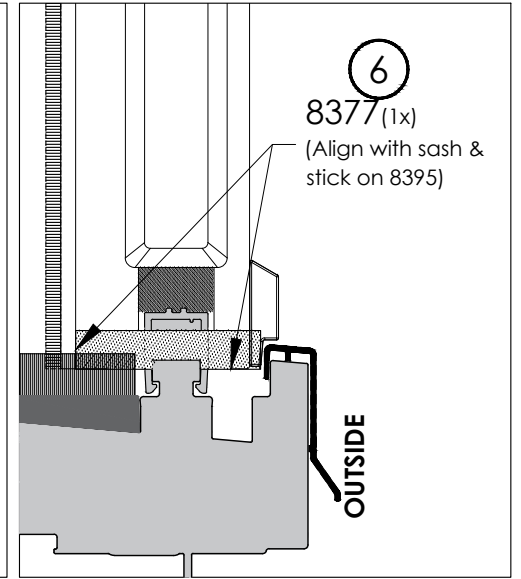
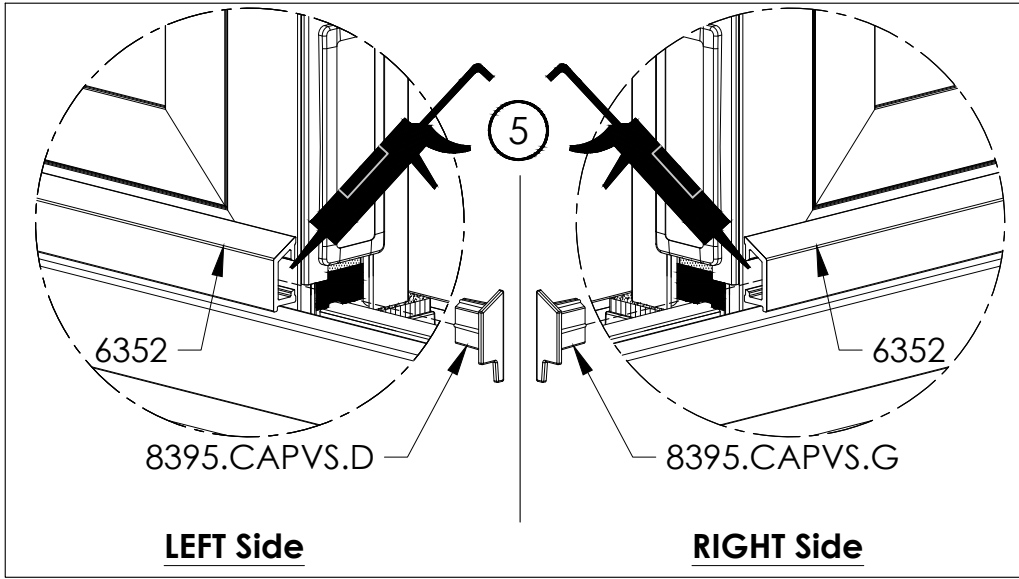
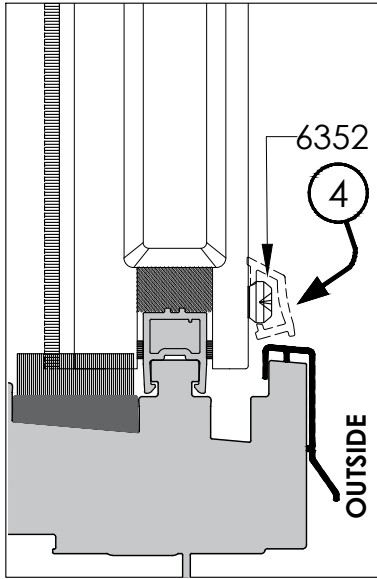



Installation of Sills Covers

\*Tools and components required for this step \*\*

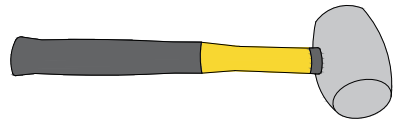

Rubber Mallet  
(1X)

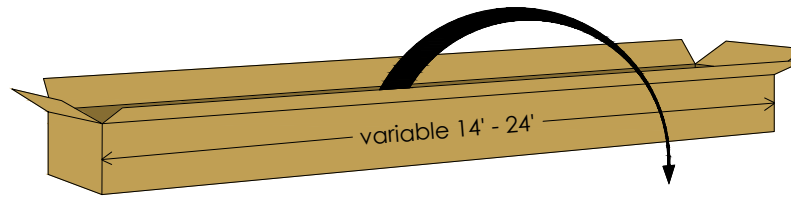

9718  
(2X)

9718-M (1X)  
(ALUMINUM)

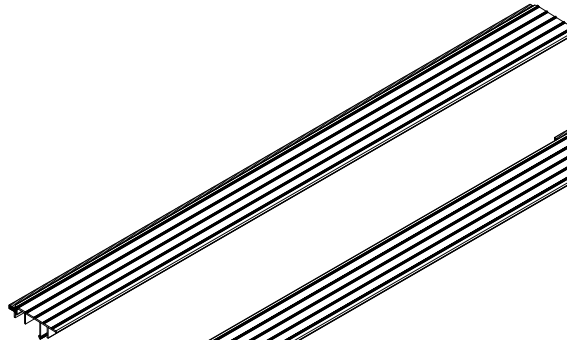

9718-F (1X)  
(ALUMINUM)

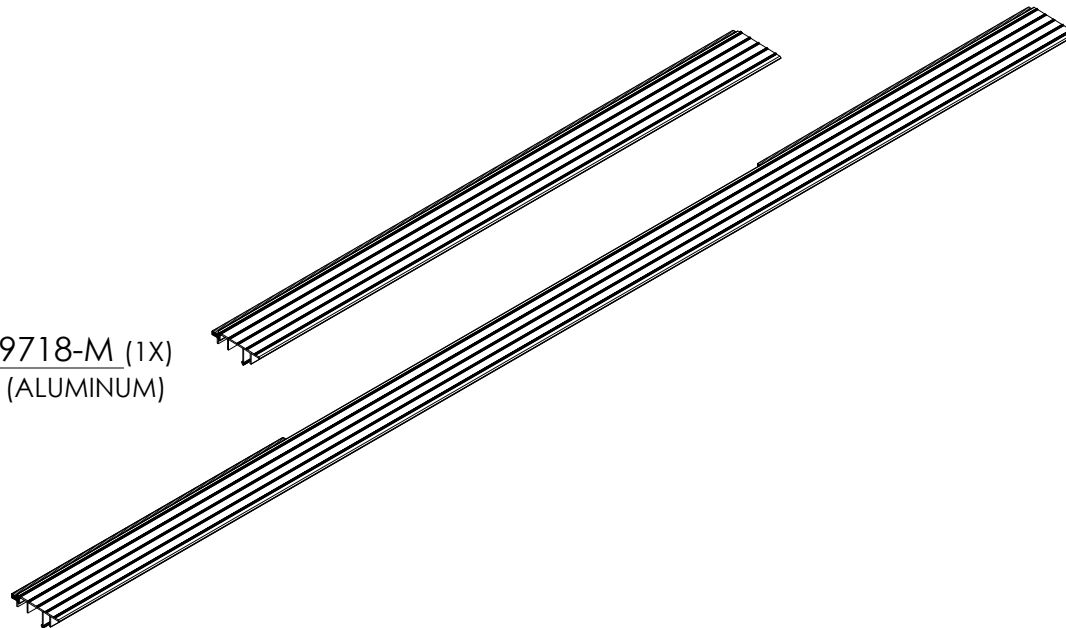



(Continued) Installation of Sills Covers

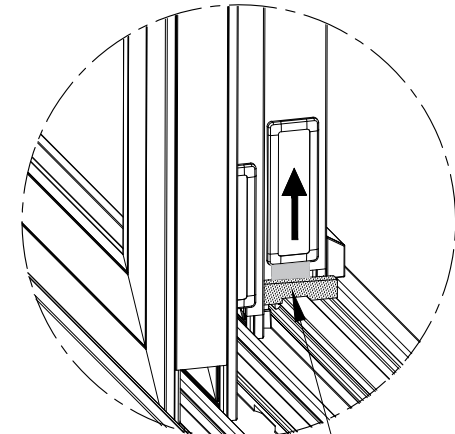

**ATTENTION:** Make sure there is a weatherstrip at each end of the part and oriented towards central sashes (closed position).



① INSURE TO COMPRESS THE FOAM

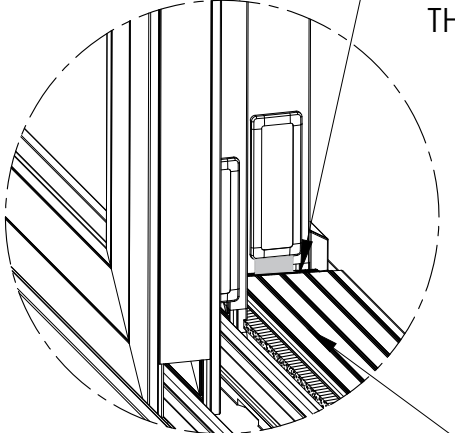

BE CAREFUL NOT TO SCRATCH THE SASH WHEN LOWERING THE 9718-F

9718-F

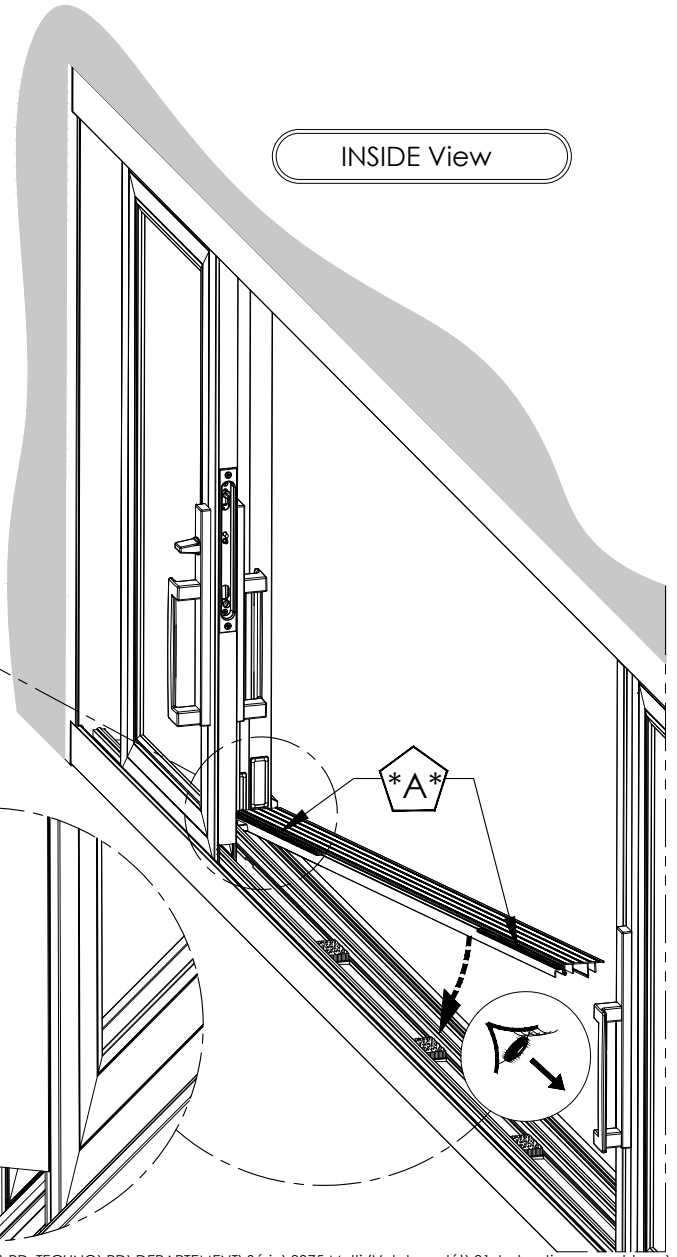
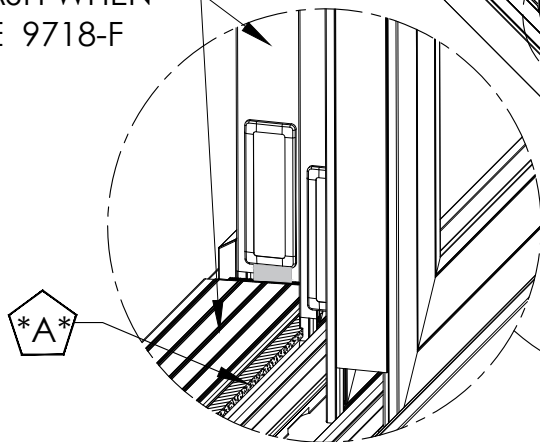
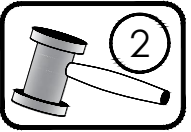

INSIDE View





STEP:  
**19**

(Continued) Installation of Sills Covers

REVISION:  
2020/05/28

PAGE:  
P58

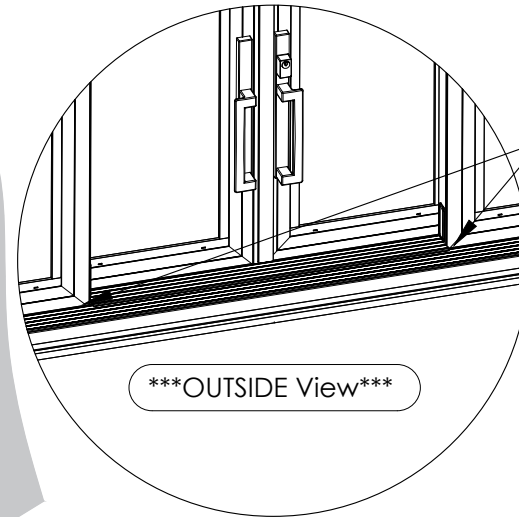
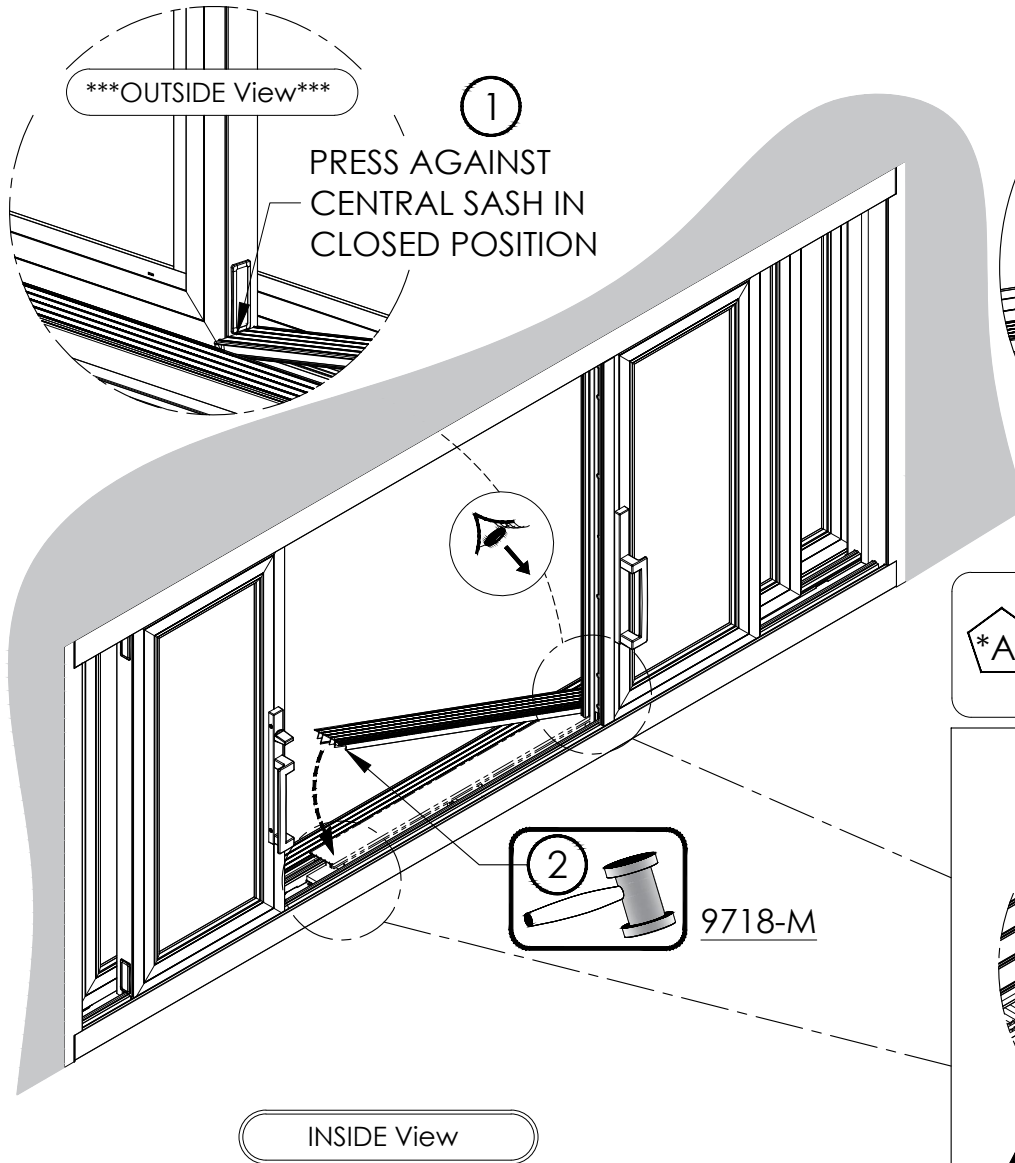

**ATTENTION:**  
Verify that the fabric fin of the long part (9718-F) is not stuck behind the small part (9718-M).

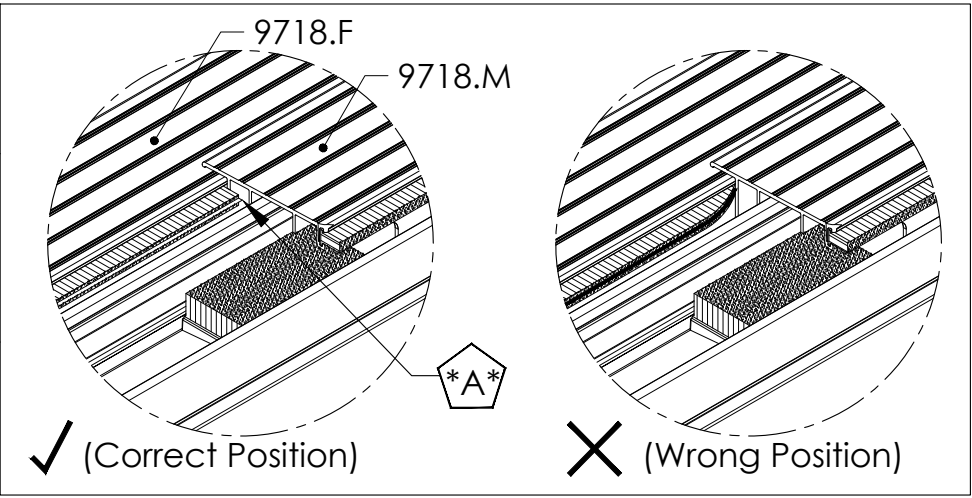



Final Ajustement

**IMPORTANT:**  
Leave a GAP every where except at fixed sash. (FLUSH)

\*Repeat (1 & 2) for the opposite side.

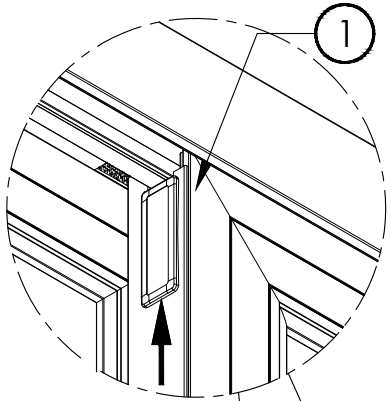

INSIDE View

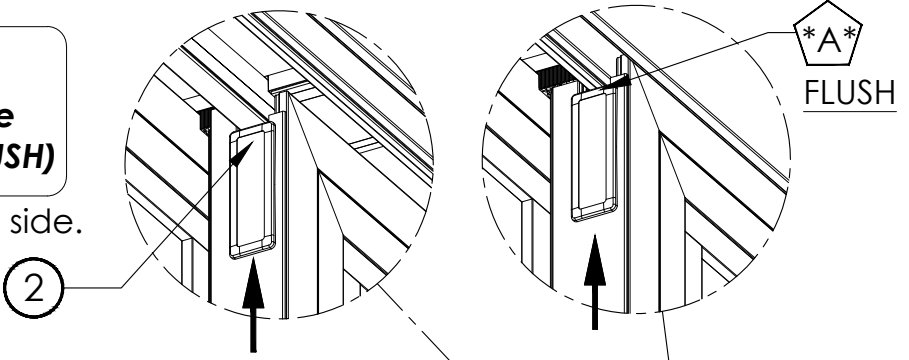

\*\*\*OUTSIDE View\*\*\*

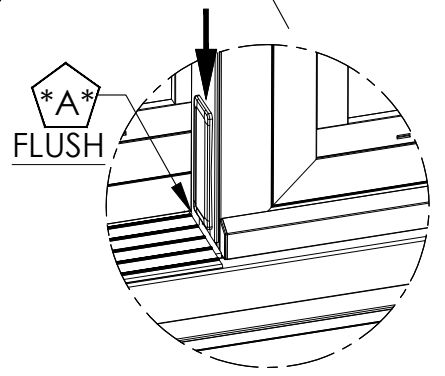
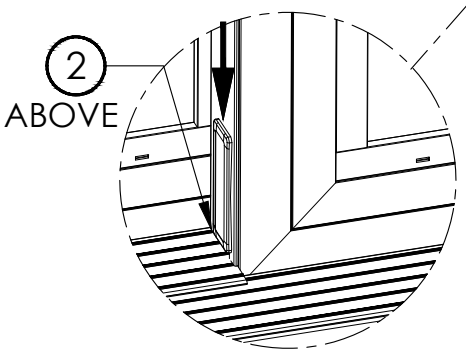
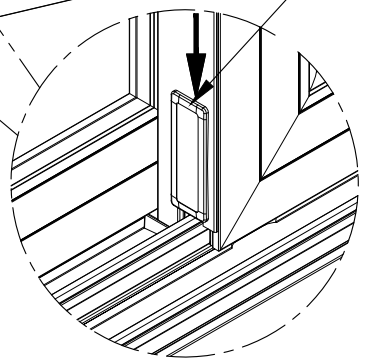
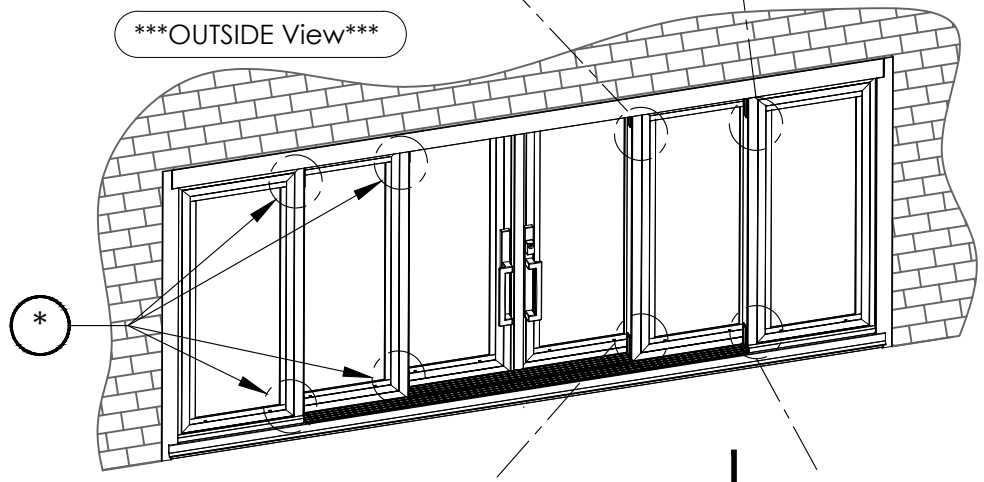
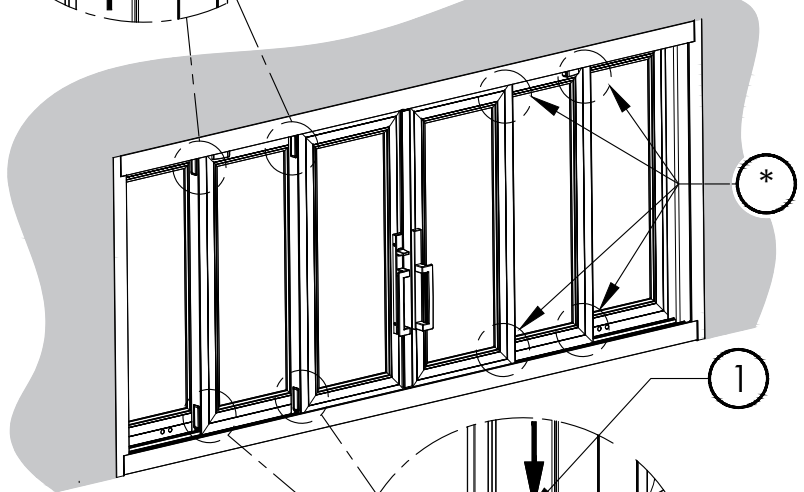

**\*\*OPTION\*\* - Preparation for RETRACTABLE SCREEN Installation**REVISION:  
2020/05/28PAGE:  
P60**\*\*\*OPTION\*\*\*****(IF A RETRACTABLE SCREEN IS PROVIDED WITH THE DOOR, FOLLOW NEXT PAGES FOR OPTIONAL PREPARATION BEFORE SCREEN INSTALLATION)**



STEP:  
**21**

**\*\*OPTION\*\* - Preparation for RETRACTABLE SCREEN Installation**

REVISION:  
2020/05/28

PAGE:  
P61

**IMPORTANT: ONLY NECESSARY IF DOOR IS WITH SCREEN.**

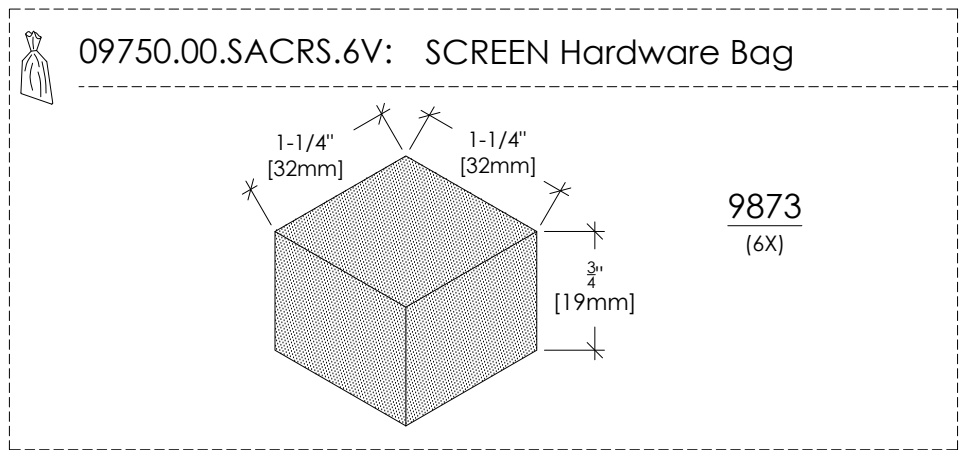
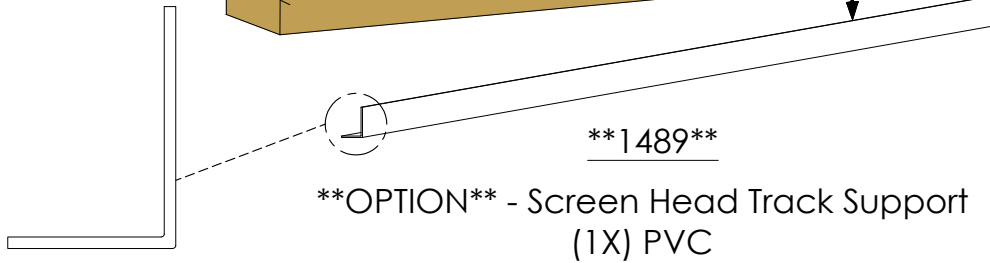
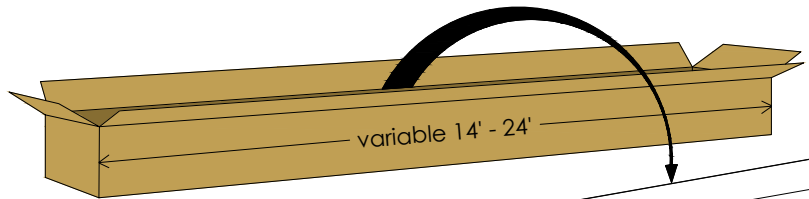
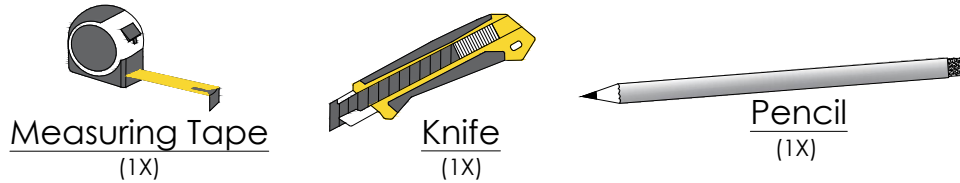

**\*\*\*OUTSIDE View\*\*\***

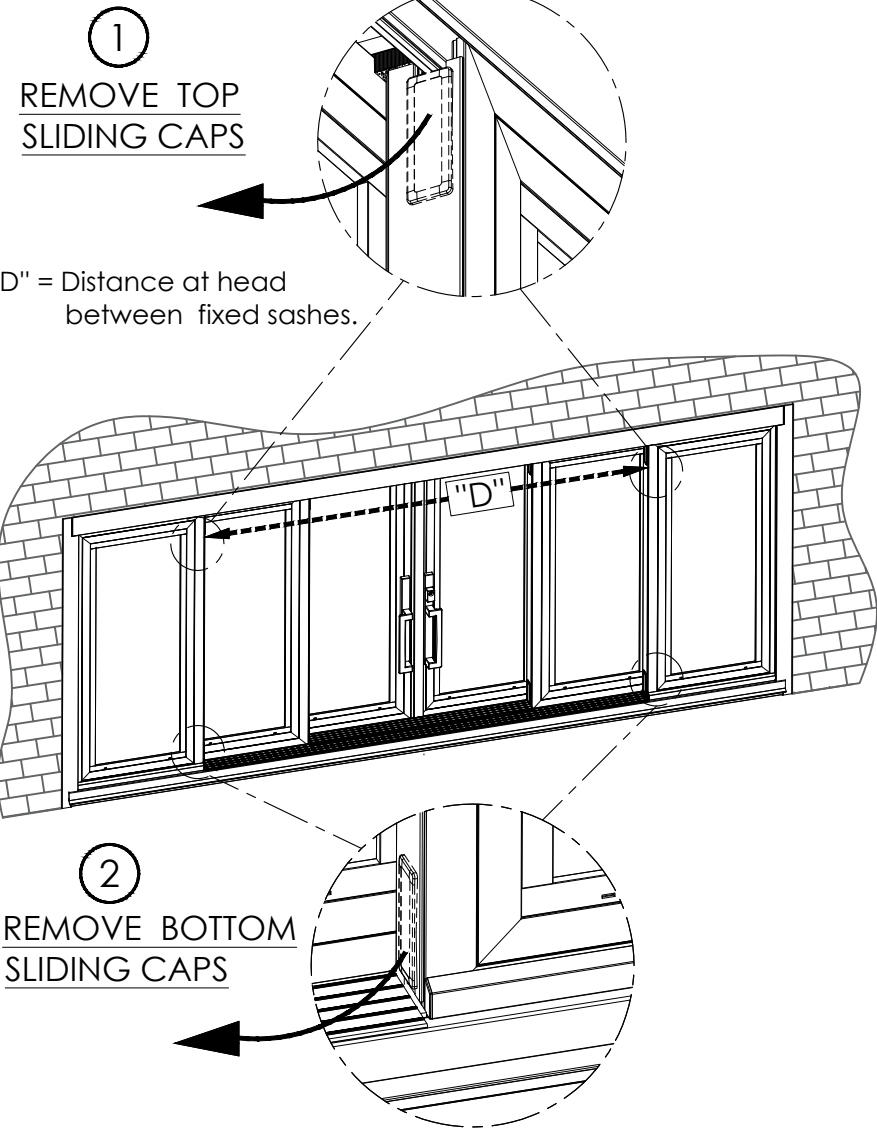





STEP: 21

**\*\*OPTION\*\* - Preparation for RETRACTABLE SCREEN Installation**

REVISION: 2020/05/28

PAGE: P62

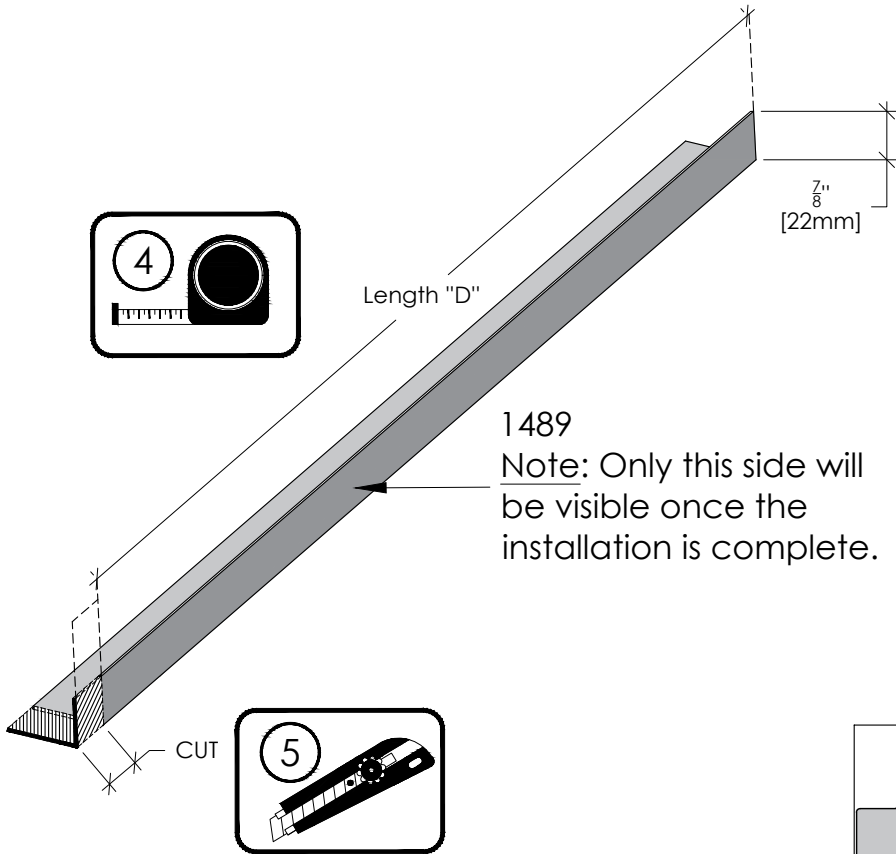

1489  
Note: Only this side will be visible once the installation is complete.

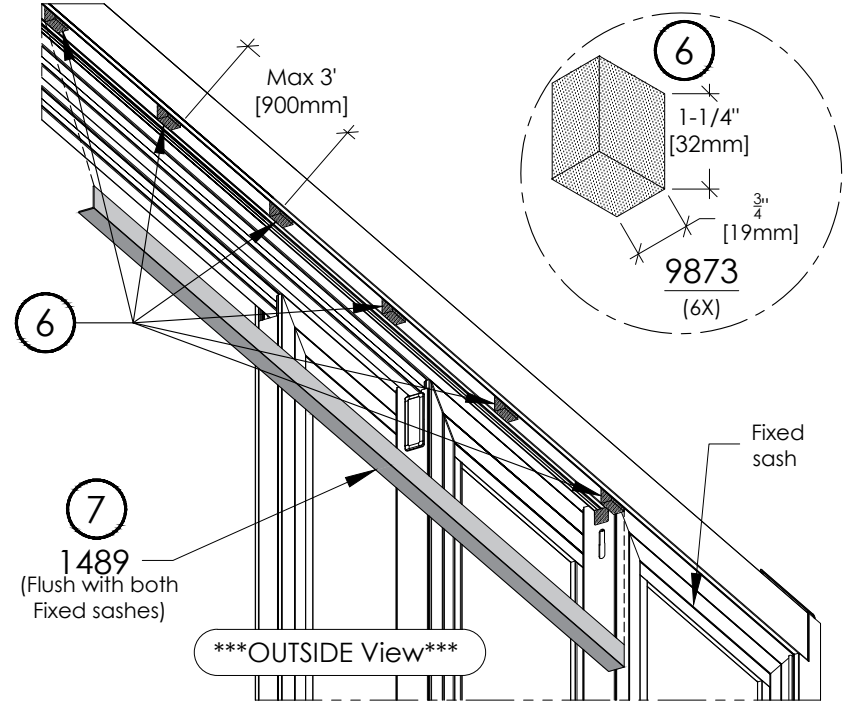

**Be sure to continue installing the screen, as the 1489 could fall if not held by the screen head track (See supplement 9950.00.GI.8300.6V.RS)**

