



Link to
assembly videos

CELESTA Impact Multi-Track Patio Door S-8385 [OXX]

REVISION:
2021/03/10

On site Assembly Instructions

09950.00.GI.8385.OXX.A

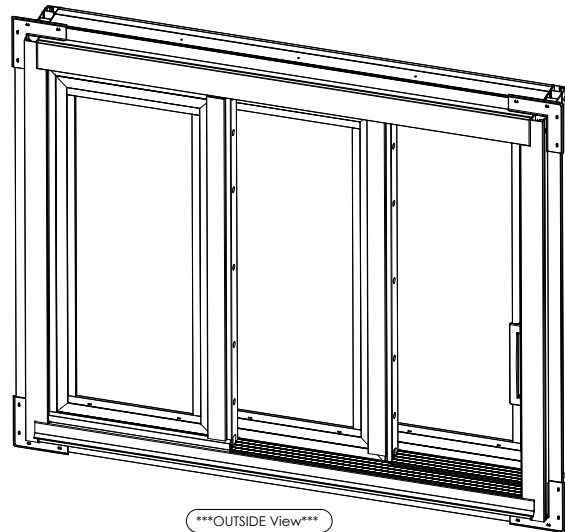

OUTSIDE View

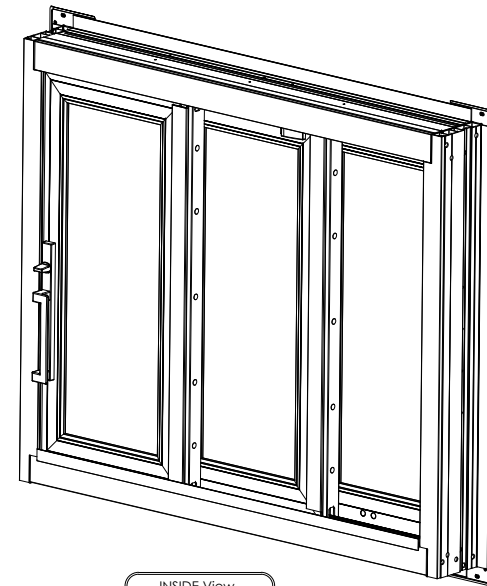

INSIDE View

CONFIDENTIAL

The contents of this document and all revisions thereof are confidential and subject to the world-wide copyrights of P.H.-Tech Inc. Any use, reproduction or disclosure thereof without the written permission of P.H.-Tech Inc. is prohibited.

Specific details of all the intellectual property rights relating to this document and the systems and components shown are available from P.H.-Tech Inc., Levis, Quebec
Canada G6V 9G9.



Table of Contents

Installation Requirements

- List of required Tools P1
- Box (HEAD / SILL / JAMBS / SASHES / SCREEN (Option) / HARDWARE) P2

✓ STEPS to Follow:

MATERIAL	<input type="checkbox"/>	1	- Validation of the Hardware	P3 - P4
	<input type="checkbox"/>	2	- Validation of HEAD Box & Preparation	P5 to P8
	<input type="checkbox"/>	3	- Validation of SILL Box & Preparation	P9 to P12
	<input type="checkbox"/>	4	- Validation of JAMBS Box & Preparation	P13 - P14
FRAME	<input type="checkbox"/>	5	- Frame Assembly	P15 to P19
	<input type="checkbox"/>	6	- Installation of the Frame	P20 to P28
SASH	<input type="checkbox"/>	7	- Installation of the Fixed Sash.....	P29 to P33
	<input type="checkbox"/>	8	- Installation of Central Sash & Head Tracks #8321	P34 to P37
	<input type="checkbox"/>	9	- Installation of Mobile Sash & Head Tracks #8321	P38 to P40
	<input type="checkbox"/>	10	- Adjustment of the Sash	P41
HEAD	<input type="checkbox"/>	11	- Installation of Head Blocks	P42 to P45
	<input type="checkbox"/>	12	- Installation of Head Covers #8323	P46 to P48
	<input type="checkbox"/>	13	- Fastening Head Tracks #8321 to the Frame	P49 - P50
	<input type="checkbox"/>	14	- Installation of Groove Cover #8331	P51 to P53
	<input type="checkbox"/>	15	- Installation of Jamb Cover (Interior) Sash Stop.....	P54 - P55
FINISHING	<input type="checkbox"/>	16	- Installation of Handle, Lock & Keeper	P56 to P58
	<input type="checkbox"/>	17	- Installation of Drip Cap	P59 to P61
	<input type="checkbox"/>	18	- Installation of Sills Covers	P62 to P64
	<input type="checkbox"/>	19	- Installation of Water bar	P65 - P66
	<input type="checkbox"/>	20	- Installation of Jamb Cover (Outside)	P67
	<input type="checkbox"/>	21	- **OPTION** - Preparation for Retractable Screen Installation.....	P68 to P70



STEP: 0

List of Required Tools

REVISION: 2021/03/10

PAGE: P1

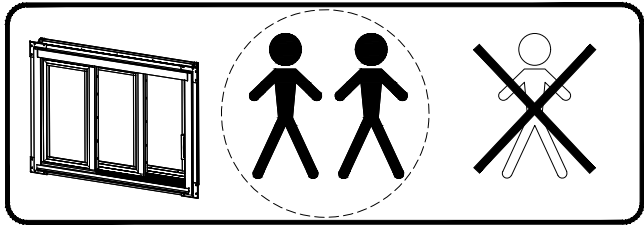

Assembly required by 2 people

IMPORTANT



Screwdriver Bit
Quadrex 6" #2 (1X)

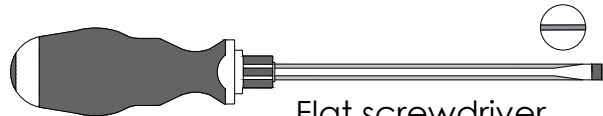

Flat screwdriver
(1X)



Phillips screwdriver
(1X)

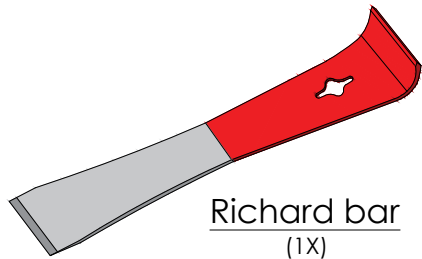

Richard bar
(1X)



Impact
(1X)

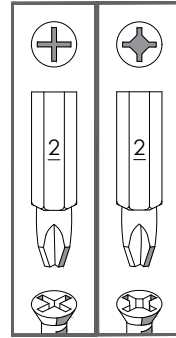

Screwdriver Bits
(2X)

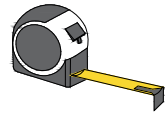

Measuring Tape
(1X)

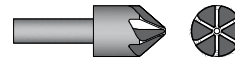

Countersink
(for #8 screw)
(min.1X)

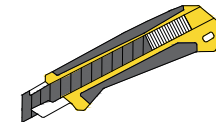

Knife
(1X)

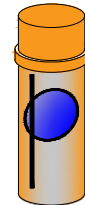

Invisible Lubricant
Silicone
(1X)

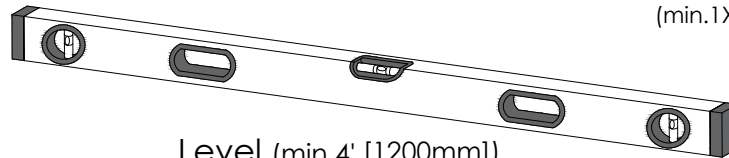

Level (min 4' [1200mm])
(1X)



Drill Bits
(min.2X)

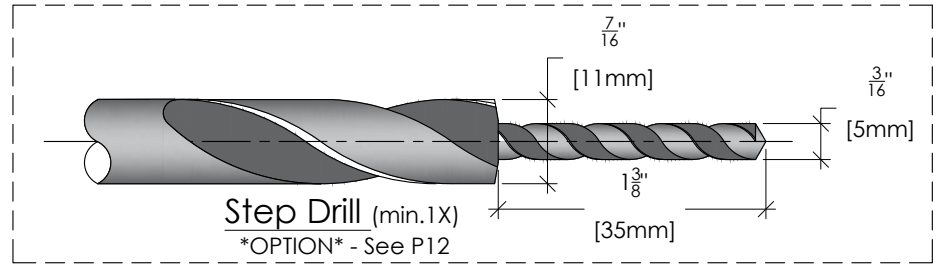
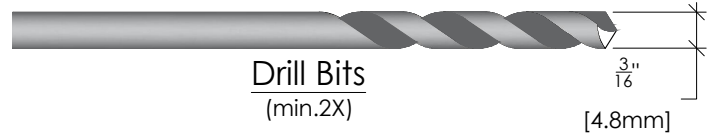

Step Drill (min.1X)
OPTION - See P12



Pencil
(1X)



Rubber Mallet
(1X)

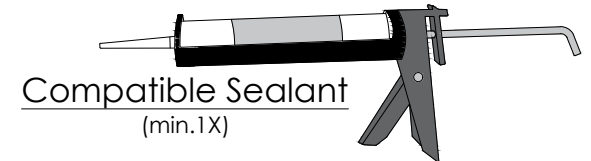

Compatible Sealant
(min.1X)



STEP:
0

List of Packaging Boxes

REVISION:
2021/03/10

PAGE:
P2

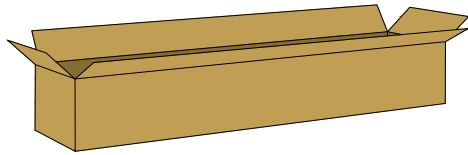

Jambs box
(1X)

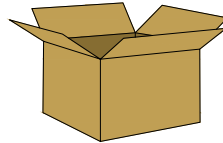

Hardware Box
(1X)

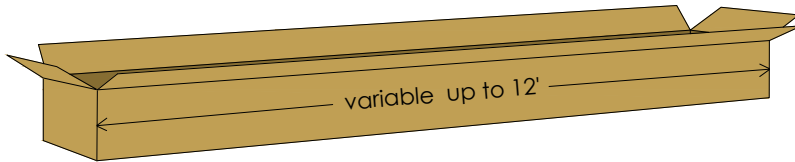

Head Box
(1X)

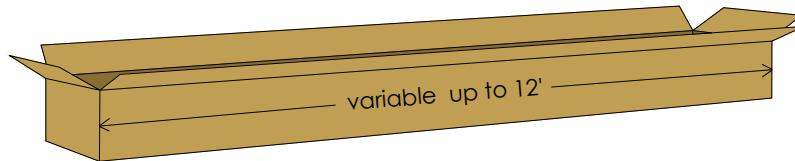

Sill Box
(1X)

****OPTION****

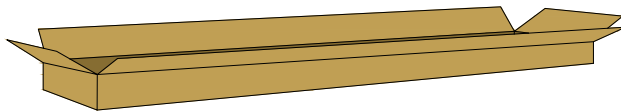

****Screen Box****
(1X)

****See label****

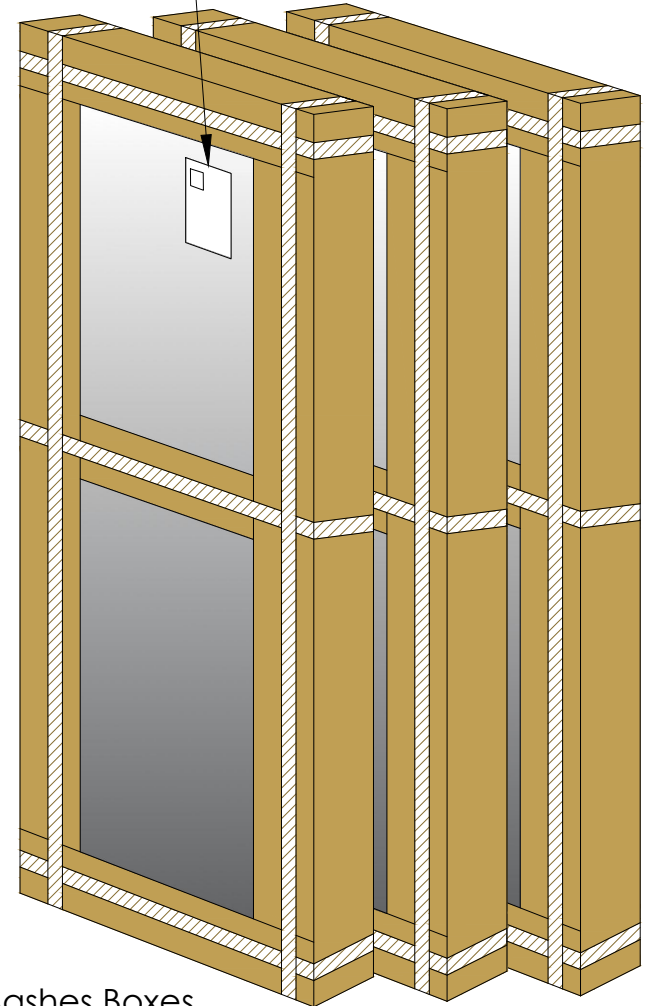

Sashes Boxes
(3X)



STEP:
1

Validation of the Hardware

REVISION:
2021/03/10

PAGE:
P3

08375.58.SACn1.3V : FRAME & SASH Hardware bag

9619.VIS08 (6X)
8942.VIS10 (24X)
8941.VIS08 (2X) *BLACK*
9876.VIS08 (4X)
9667.CAPUC (4X) (IN)
8784 (1X)
9853 (5X)
8770.LAMCO (4X) (OPTION) - (If with nailing fine)
8397.58.ANCVS (1X)
8389.CAPEV (1X) (IN)
8389.ARREV (1X)

09750.58.S8385.3V : Installation bag

9683.VIS10 (30X)
9667.CAPUC (9X) *OPTION* (IN)
9759.VIS08 (9X)
9764.VIS10 (18X)
9859 (9X)

A
IMPORTANT:
 Hardware are provided for
 Installation in Wood-frame
 construction.
 *Nails or Tapcon screws are
 NOT provided.

(IN)
 *If painted door
 (OUT= Outside) or (IN=Inside),
 rather use parts on red bag in
 Sill box &/or Sash box.*





STEP:
1

(Continued) Validation of the Hardware

REVISION:
2021/03/10

PAGE:
P4

08380.00.SACn2.3V : HEAD Hardware bag

8942.VIS10 (19X)

8941.VIS08 (8X) ***BLACK***

8940 (1X)

8703.BMSCF (1X) ****Assembled with foam 8373****

00703.ADM35 (2X) ****Assembled with shim 8789****

08385.54.EXTRA.3V : EXTRA Bag - IMPACT

9752.SS.VIS06 (13X)

9853 (2X) - White

9853 (2X) - Black **(*OPTION*)**

08375.58.SACn3.3V : FINISHED Hardware bag

8813.VIS10 (4X)

8377.GAPSF (1X) **Adhesive backside** **not required OXX**

9150.CAPUC (2X)

8395.58.CAPVS.G (1X) **not required OXX**

8395.58.CAPVS.D (1X)

09250.SS.KT.ENS2P : SS Lock & Keeper bag

9250.SS.SER2P (1X)

9250.SS.GACHE (1X)

9149.SS.VISME (#10 x 3/4") (2X) *** Not required ***

Screw #10 x 2-1/2" (2X)

9250.SS.VISGA (#10 x 1-3/4") (4X)



Validation of HEAD Box & Preparation

Tools and hardware required for this step

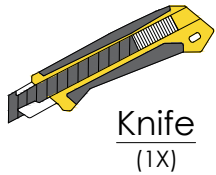

Knife
(1X)

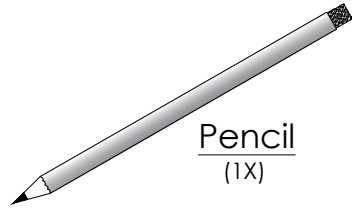

Pencil
(1X)

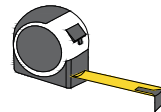

Measuring Tape
(1X)

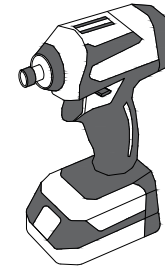

Impact
(1X)

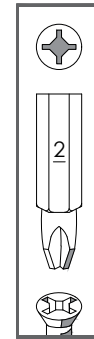

Screwdriver Bit
(1X)



08375.58.SACn1.3V : FRAME & SASH Hardware bag

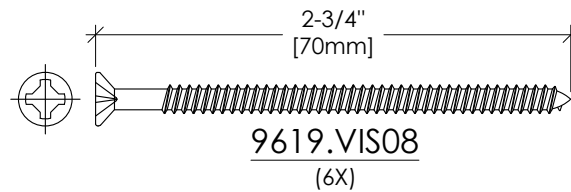

Countersink
(for #8 screw)
(min.1X)



STEP:
2

(Continued) Validation of HEAD Box & Preparation

REVISION:
2021/03/10

PAGE:
P6

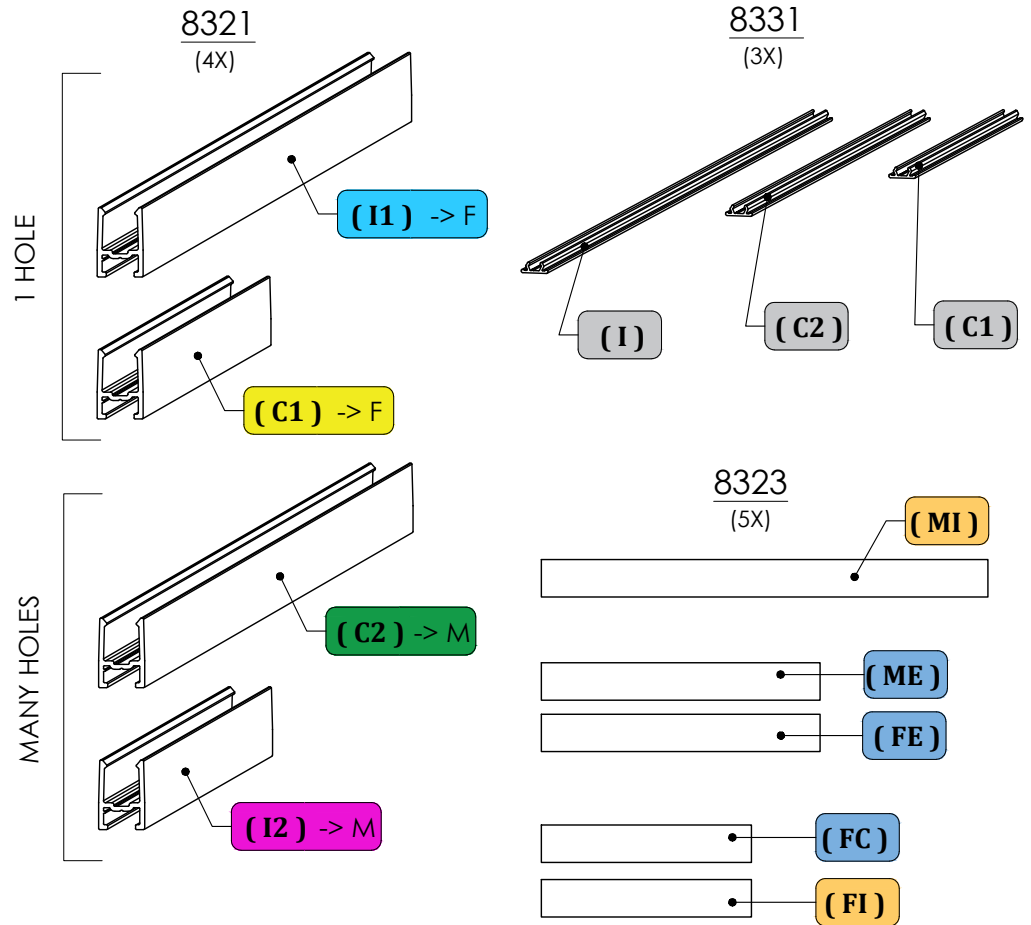
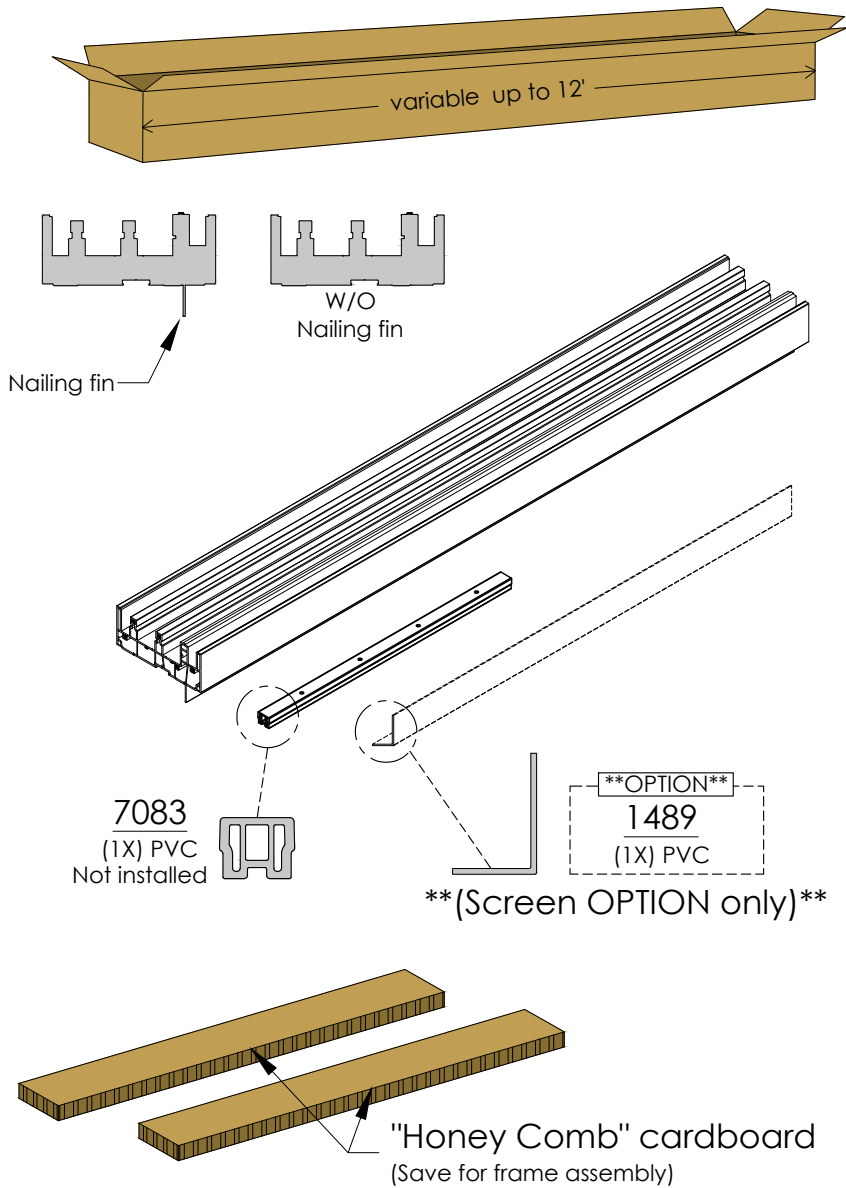

A Save components 8321 - 8323 - 8331 into the Head box for further installation. (See Step 8 to 14)

****If Screen OPTION**** : Save also component 1489 for further installation. (See Step 21)



(Continued) Validation of HEAD Box & Preparation

REVISION: 2021/03/10

PAGE: P7

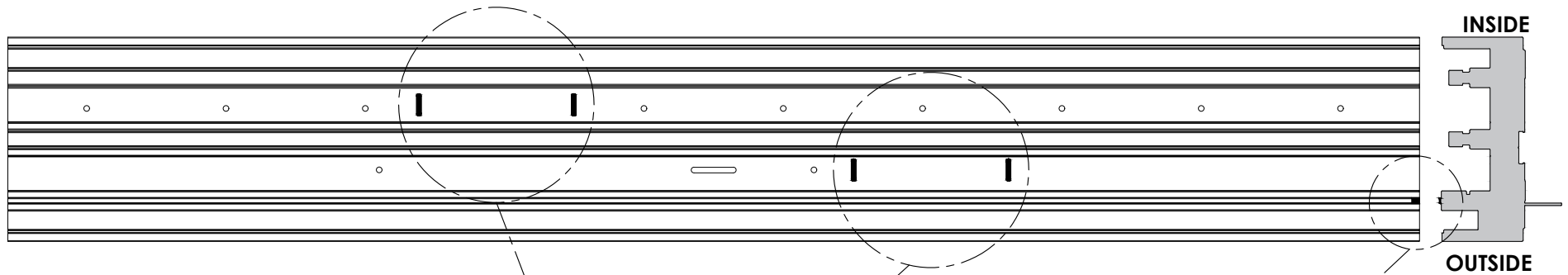

Trace the positioning marks (4X) to facilitate installation of Head blocks. (See step 11)

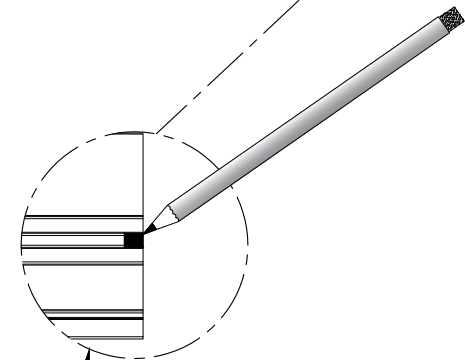
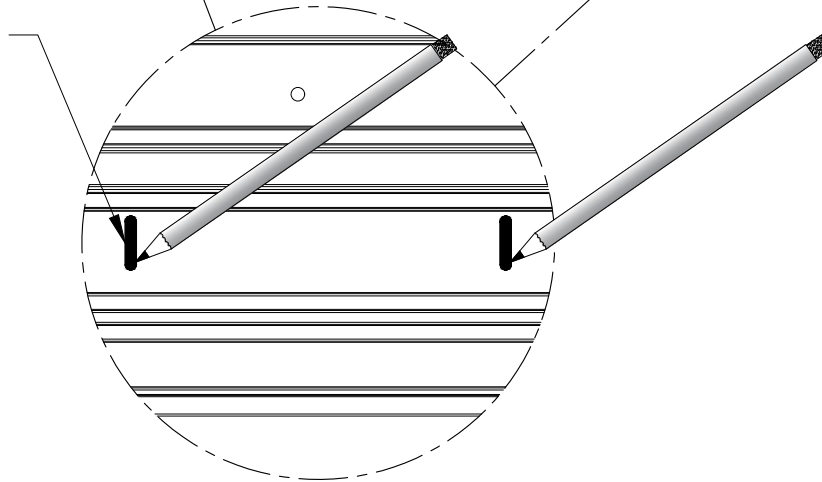

Trace the positioning mark (1X) to facilitate installation of Head support. (See next page)



STEP:
2

(Continued) Validation of HEAD Box & Preparation

REVISION:
2021/03/10

PAGE:
P8

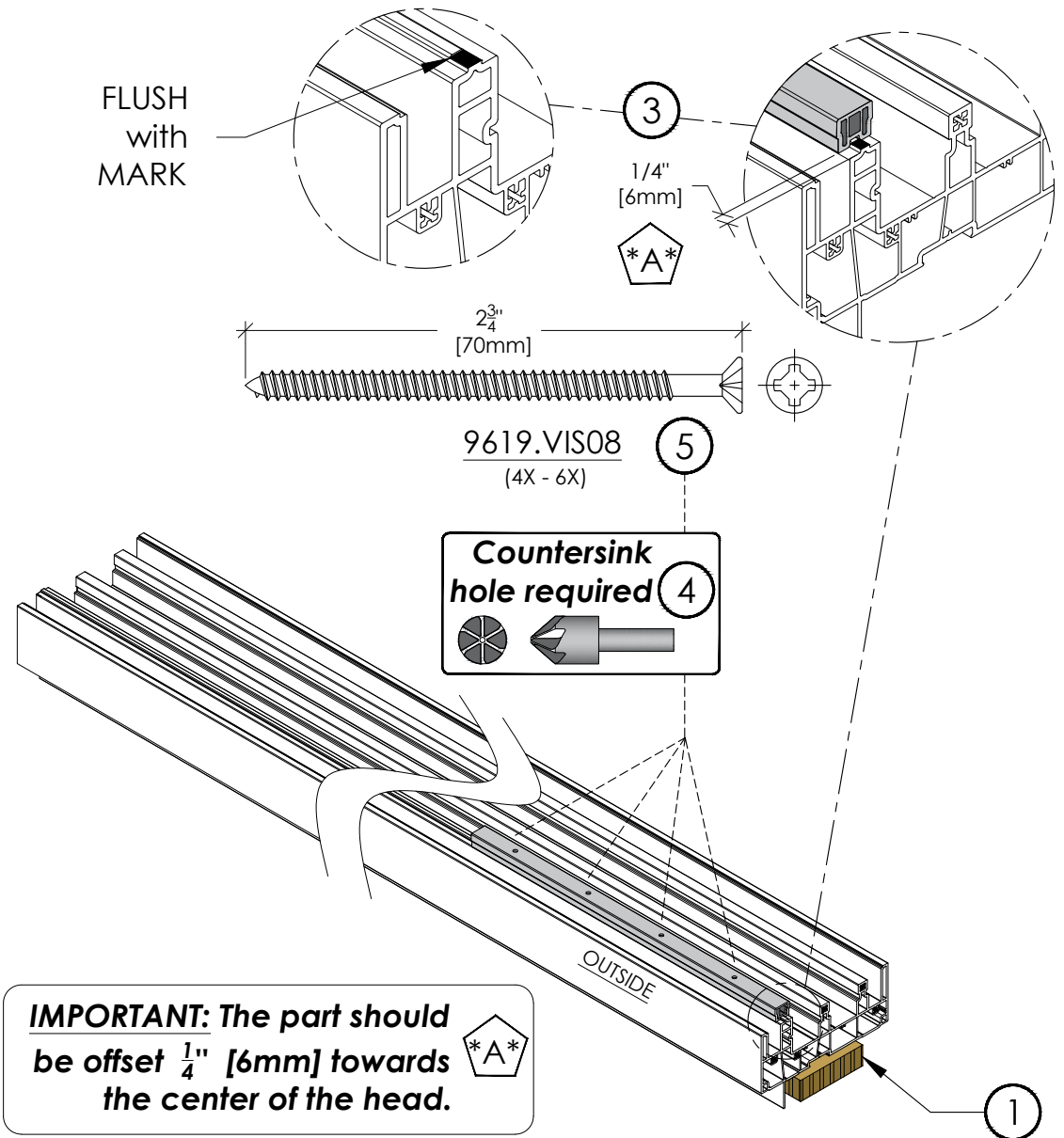
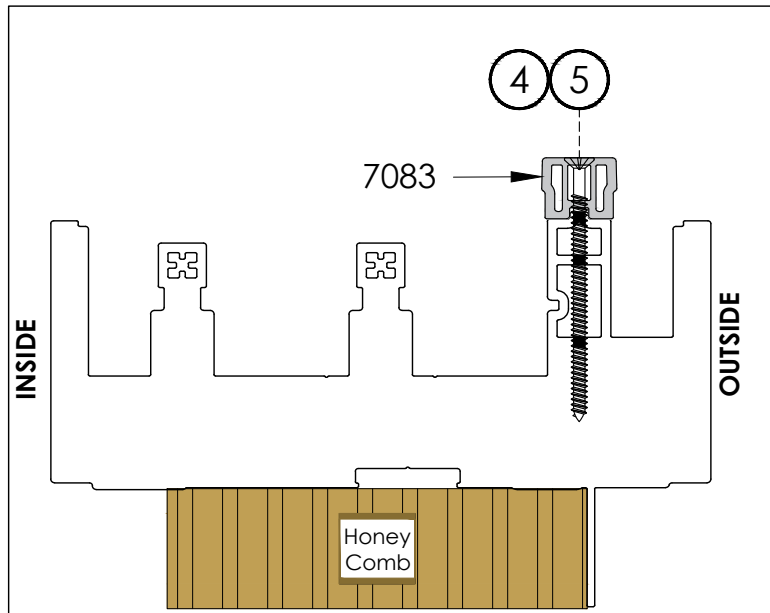
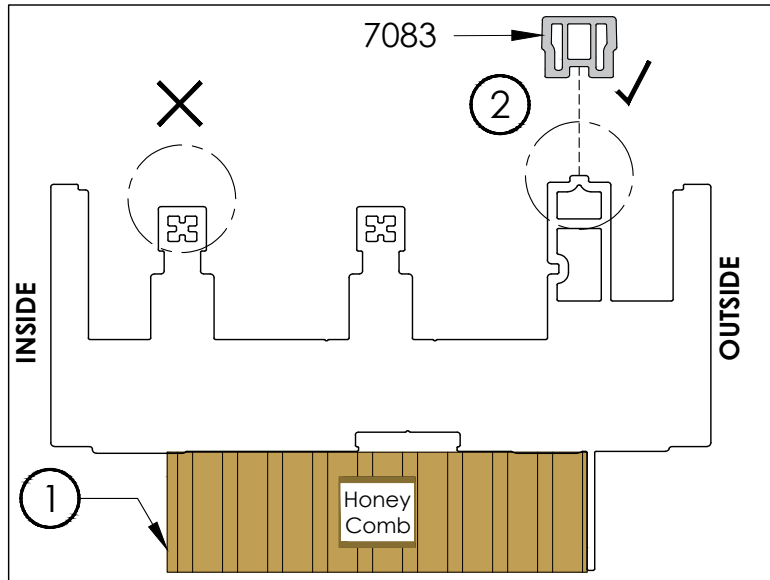

IMPORTANT: The part should be offset $\frac{1}{4}$ " [6mm] towards the center of the head.



STEP:
3



Validation of SILL Box & Preparation

REVISION:
2021/03/10

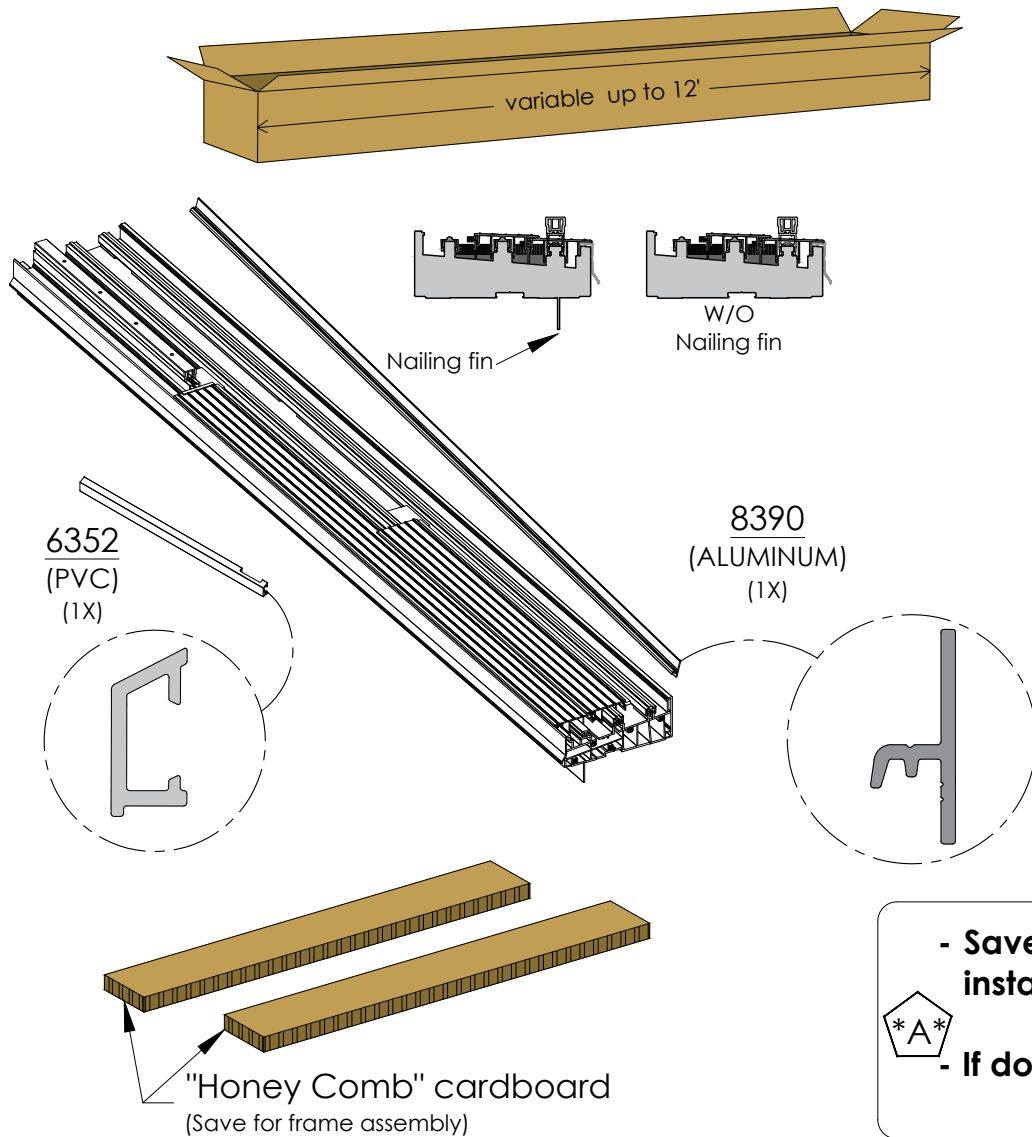
PAGE:
P9

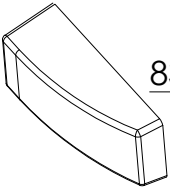

*OPTION if painted door:
The red bag contains the
painted hardware.

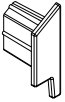
INSIDE PAINT	 9667.CAPUC (4X) Fixed sash + (9X) Sill Option*	 8389.CAPEV (1X)
	not required OXX  8395.58 CAPVS.G (1X)	 8395.58.CAPVS.D (1X)
OUTSIDE PAINT		

- Save component 6352 into the HEAD box for further installation. (See Step 17)
- If door is painted: save also the red bag.



STEP:
3

(Continued) Validation of SILL Box & Preparation

REVISION:
2021/03/10

PAGE:
P10

Tools and hardware required for this step

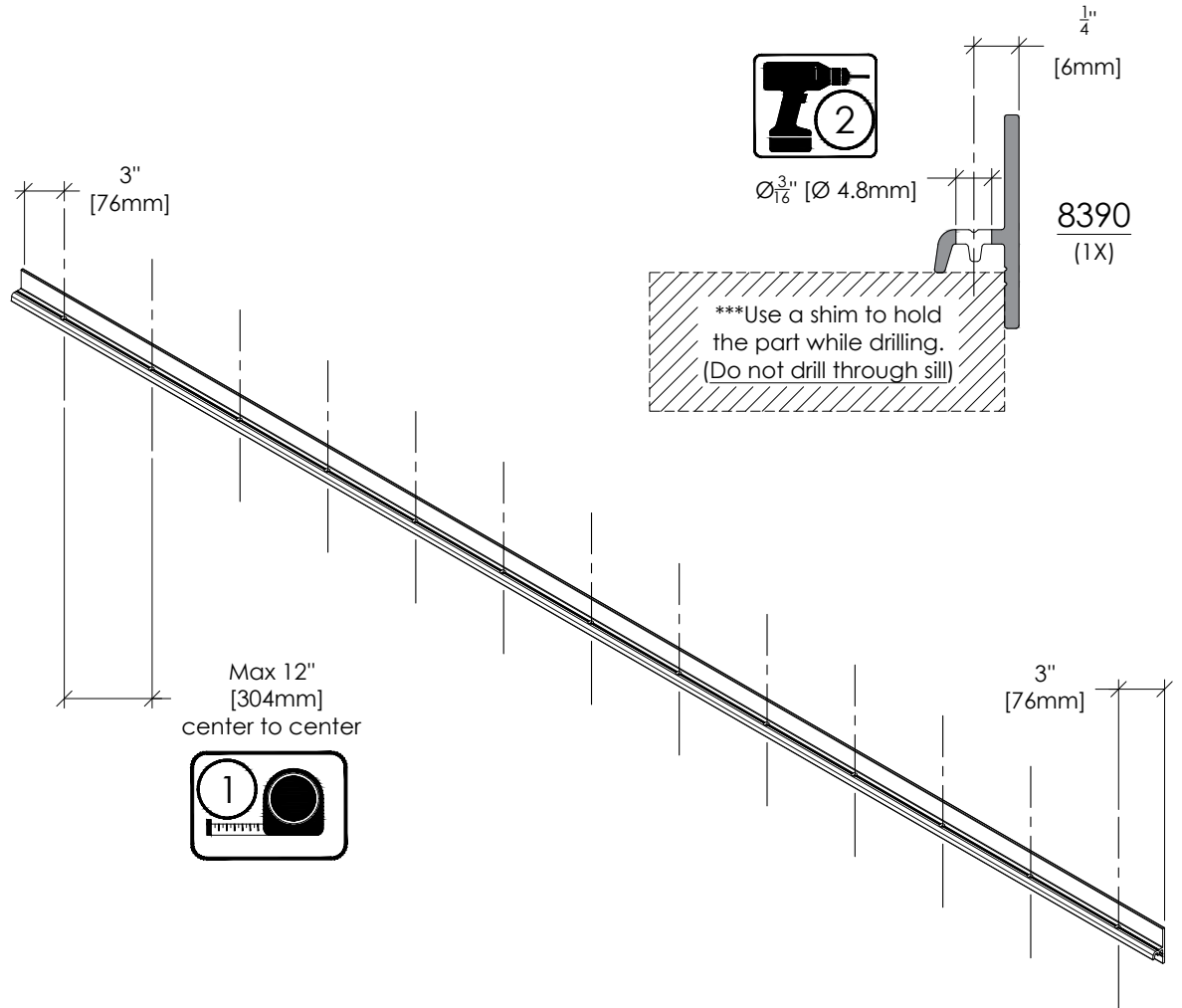
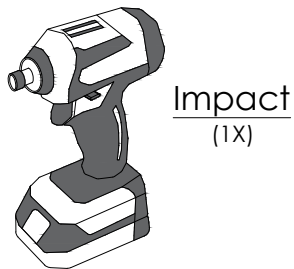
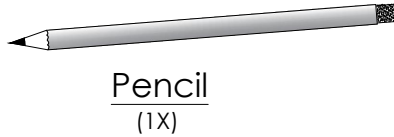
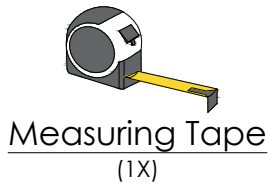

A Save component 8390 into the HEAD box for further installation. (See Step 19)



STEP:
3

(Continued) Validation of SILL Box & Preparation

REVISION:
2021/03/10

PAGE:
P11

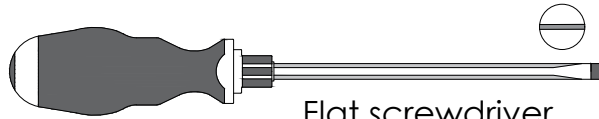

Flat screwdriver
(1X)

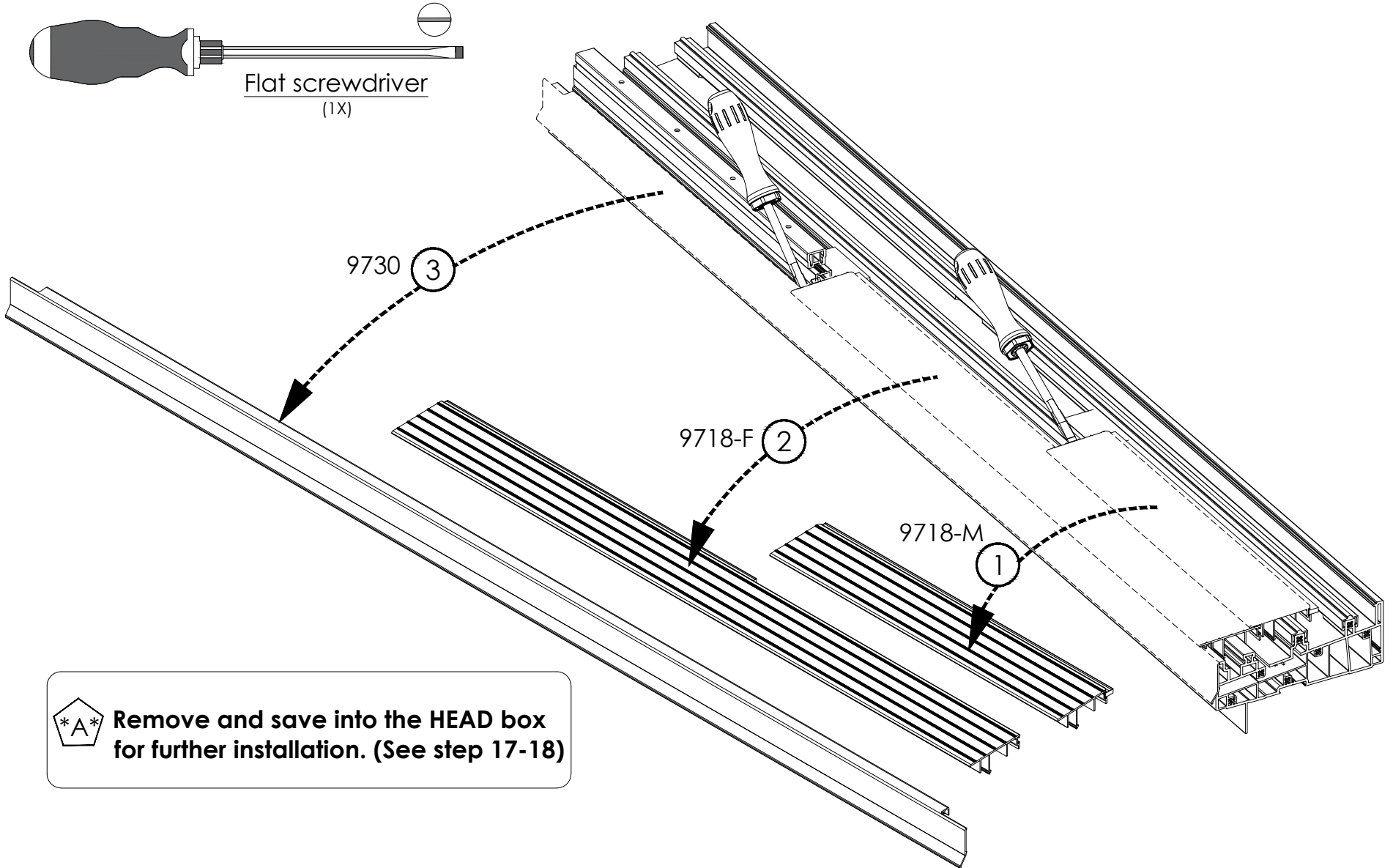

A Remove and save into the HEAD box for further installation. (See step 17-18)



STEP:
3

(Continued) Validation of SILL Box & Preparation

REVISION:
2021/03/10

PAGE:
P12

OPTION

Concrete application only (See P15)

(Do not take care of this page for wood application)

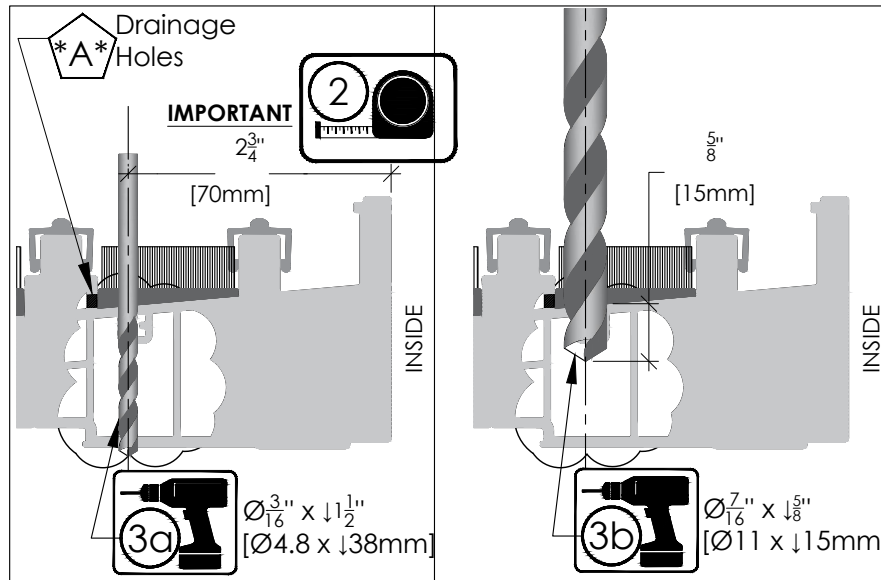

Tools and hardware required for this step

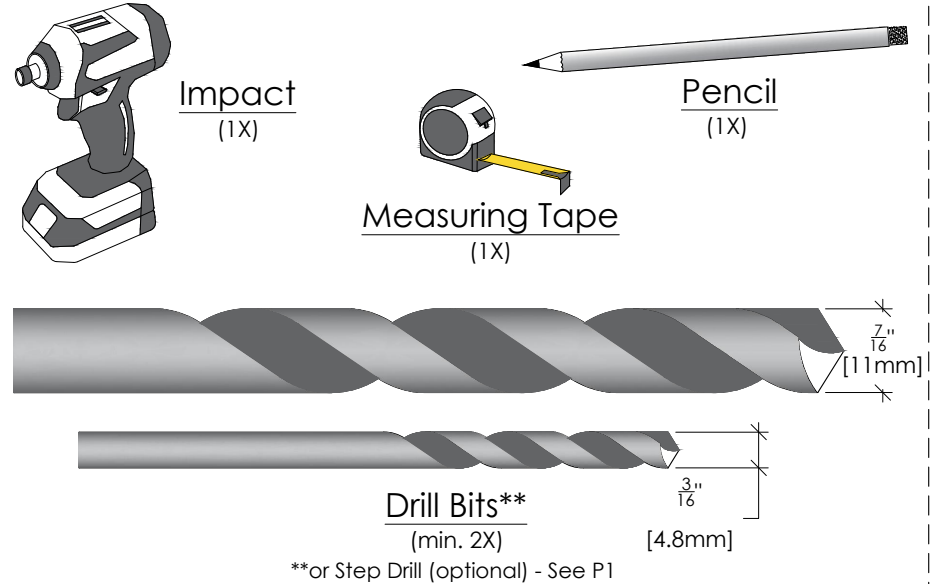

A **IMPORTANT:** If necessary, move the installation holes about 1" [25mm] from drainage holes to not drill in front of it. (Max 16" C-C). Otherwise, sealant and cap may obstruct the drainage holes. (See P26)

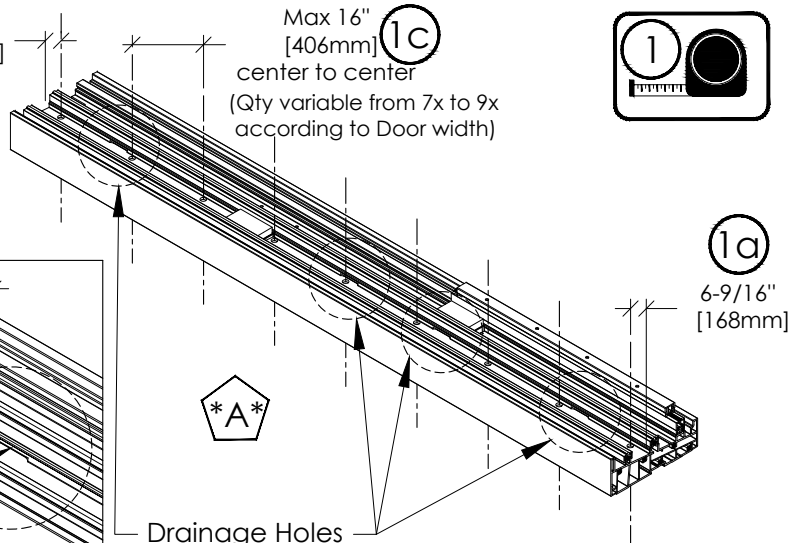
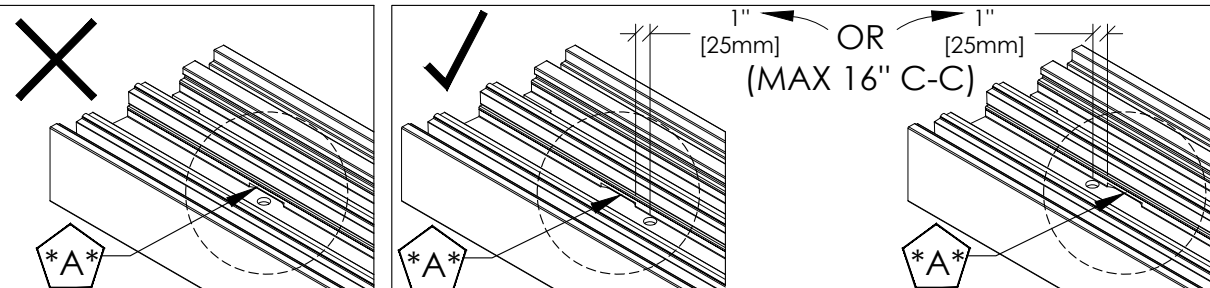



STEP: **4**

Validation of JAMBS Box & Preparation

REVISION: 2021/03/10

PAGE: P13

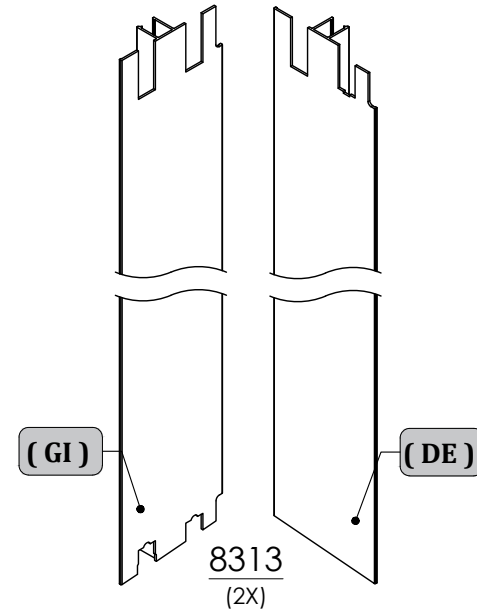
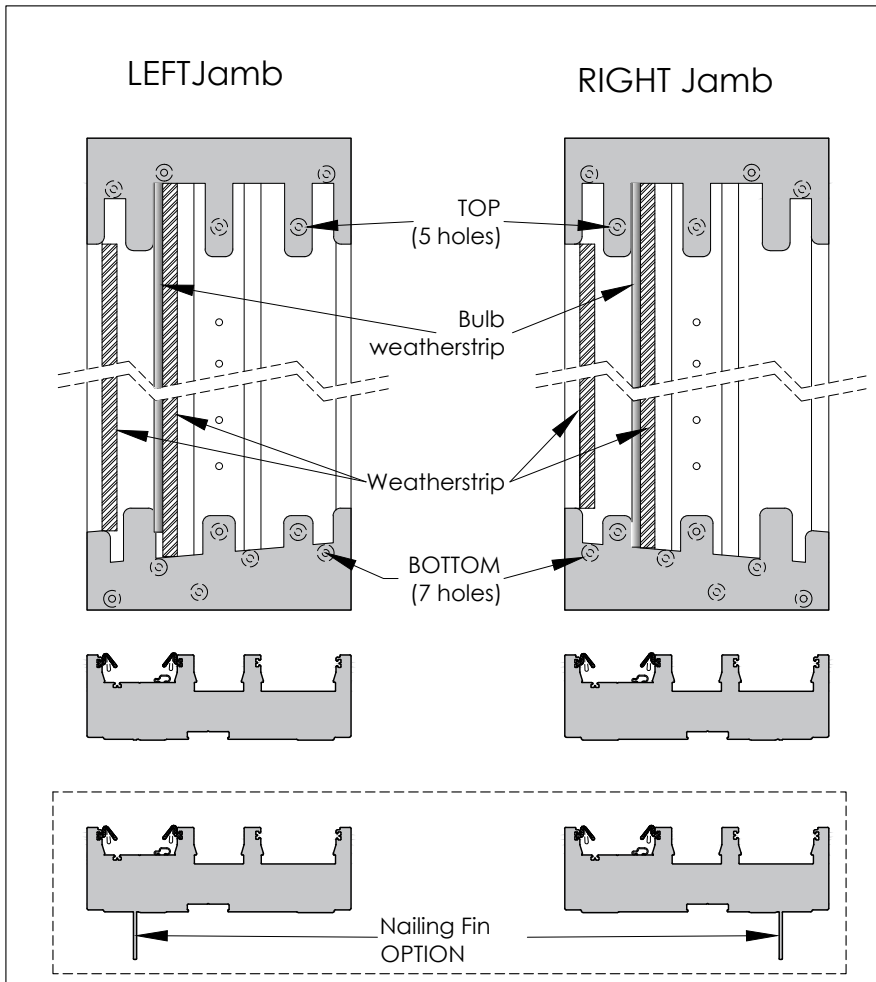
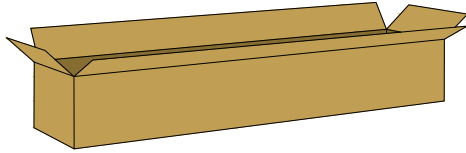

A Save components 8313 into the HEAD box for further installation. (See Step 15 & 20)

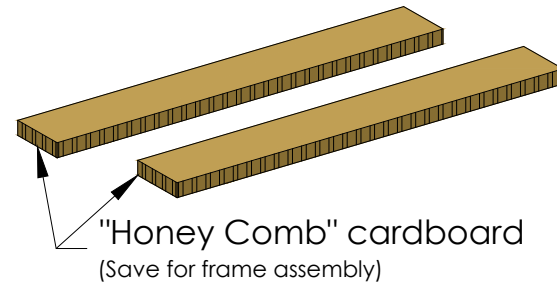



STEP:
4

(Continued) Validation of JAMBS Box & Preparation

REVISION:
2021/03/10

PAGE:
P14

A Make sure the distance between each existing holes is MAX 16" [406mm] c-c. (If required, add extra hole between them).

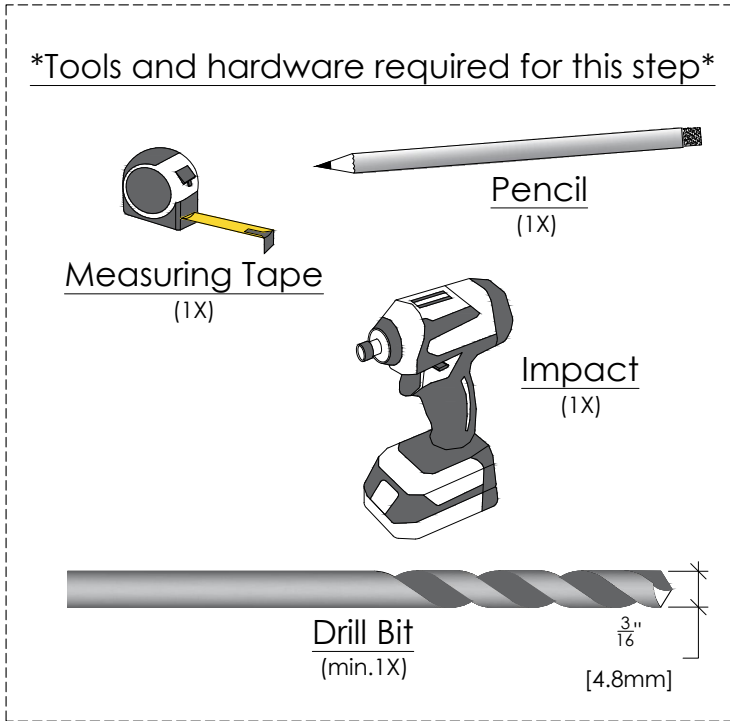

1 Select the appropriate drilling pattern for each Jamb according to the door height. (H=Door Height or Jamb length)



2 Drill holes on site according to the door height.

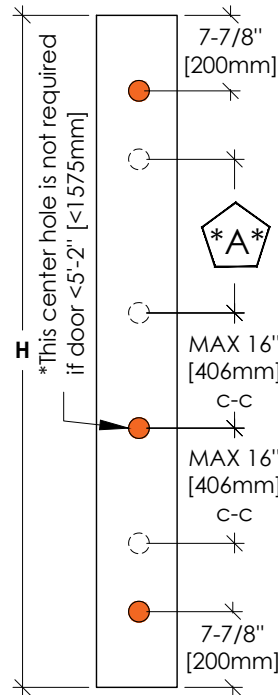
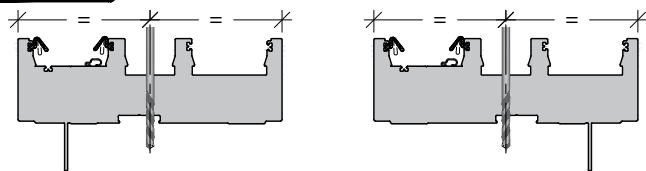

H=
Less than 5'-9⁹/₁₆"
<[1767mm]

2 ○ Actual (3X)
● Add (3X)*
On site

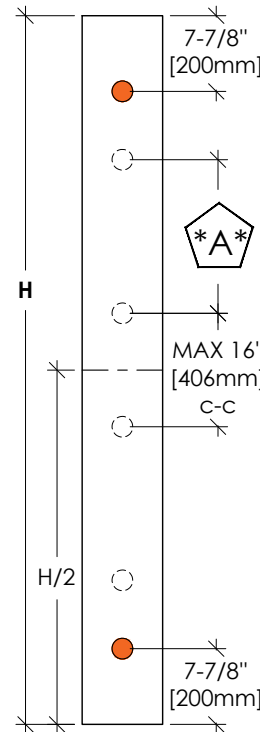

H=
5'-9⁵/₈" to 6'-6"
[1768 to 1982mm]

2 ○ Actual (4X)
● Add (2X)
On site

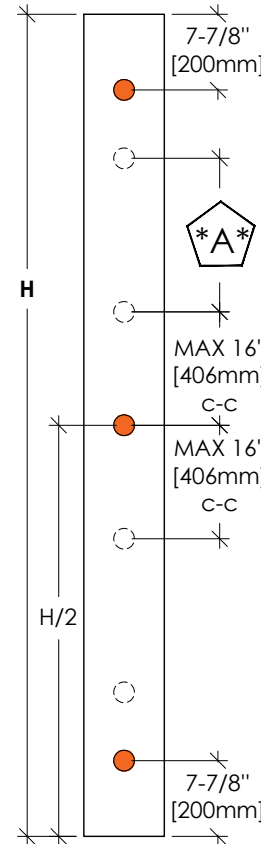

H=
6'-6¹/₁₆" to 7'-1⁵/₈"
[1983 to 2175mm]

2 ○ Actual (4X)
● Add (3X)
On site

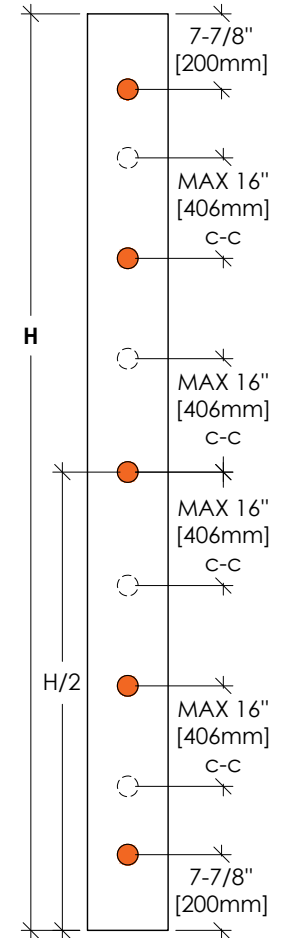

H=
7'-1¹¹/₁₆" to 7'-11¹/₂"
[2176 to 2425mm]

2 ○ Actual (4X)
● Add (5X)
On site



ATTENTION:
SELECT THE INSTALLATION METHOD ACCORDING TO ILLUSTRATIONS SHOWN in P15 & P16.
BEFORE ASSEMBLY THE FRAME, MAKE SURE ALL PARTS ARE PROPERLY PREPARED.

Hardware are provided for Installation in Wood-Frame construction. (Tapcon screws or Nails are NOT provided).

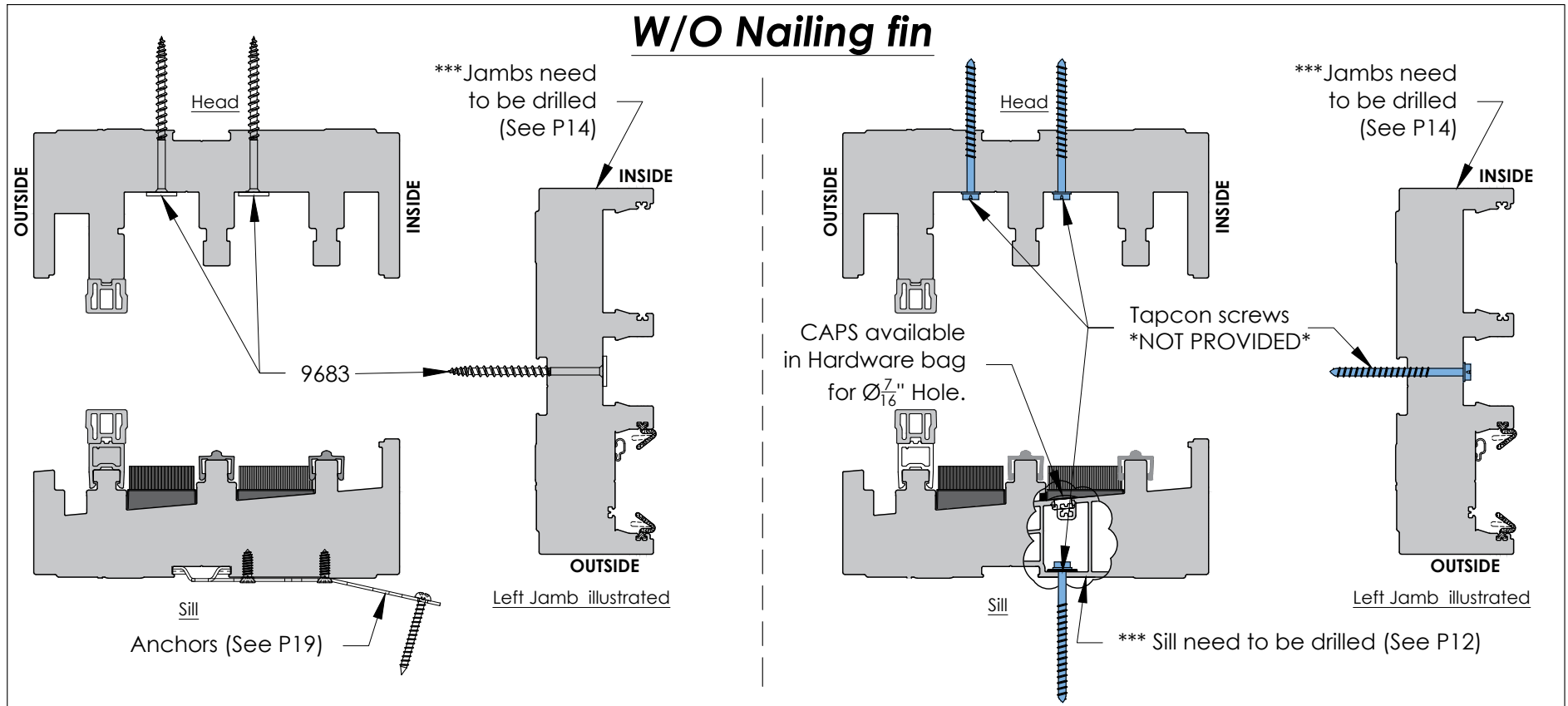

WOOD APPLICATION
(Installation with Screws & Anchors)
SEE P24

CONCRETE APPLICATION
(Installation with Tapcon screws)
SEE P25 & 26



STEP:
5

(Continued) Frame Assembly

REVISION:
2021/03/10

PAGE:
P16

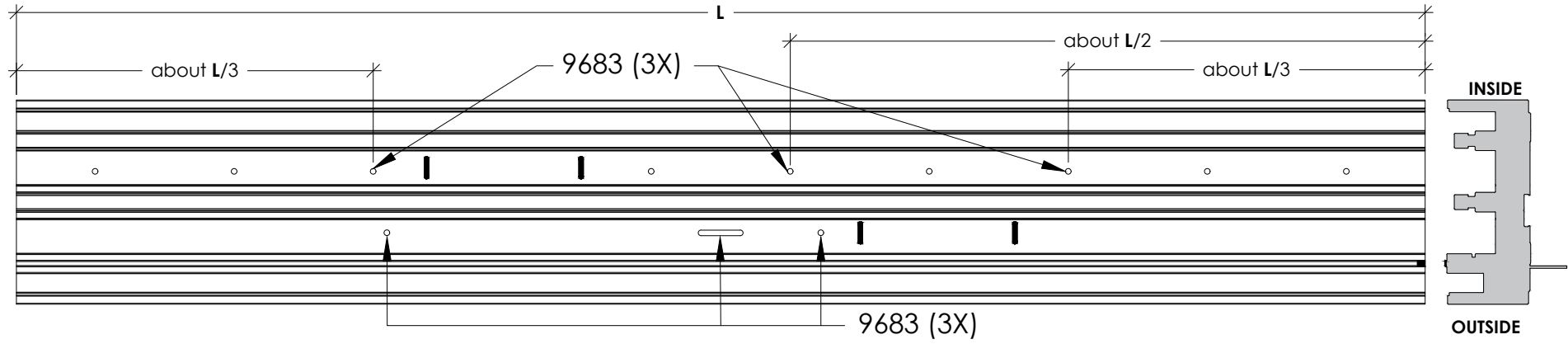
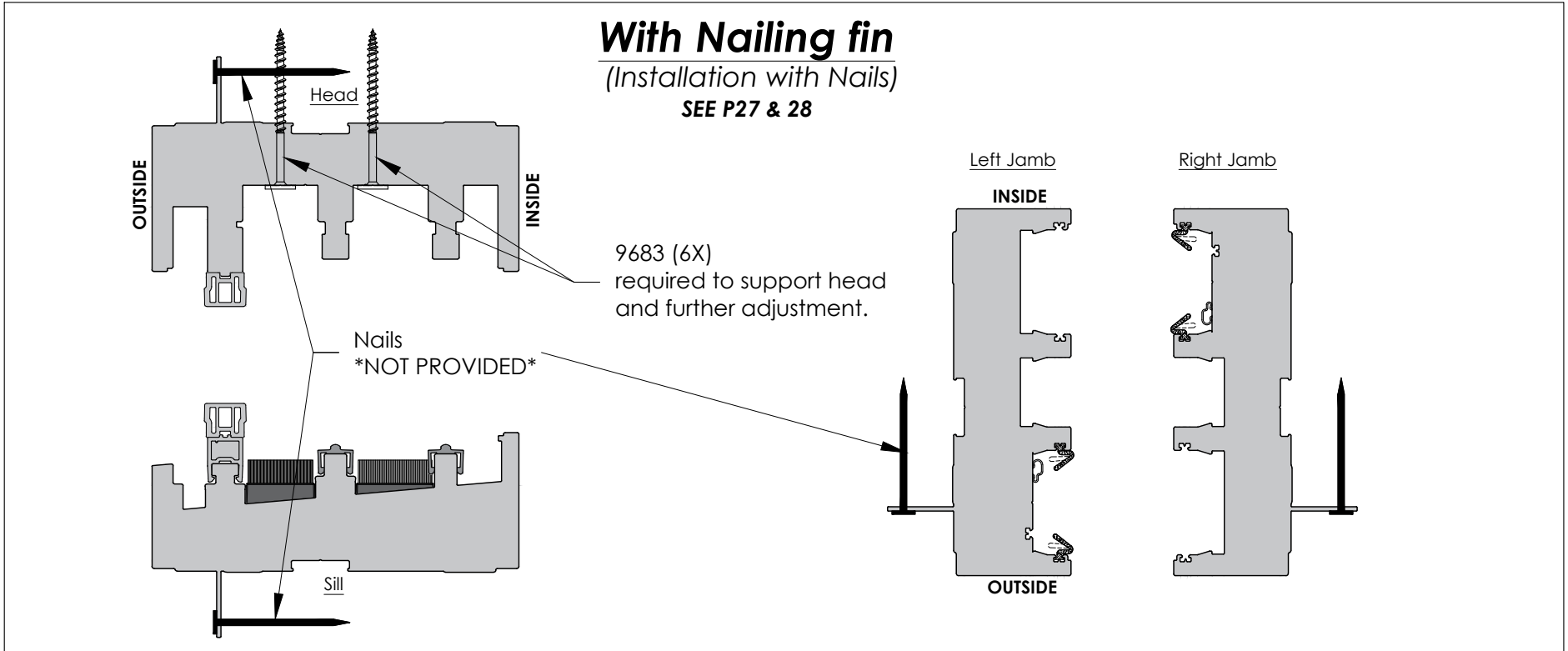



(Continued) Frame Assembly

Tools and hardware required for this step



Impact
(1X)

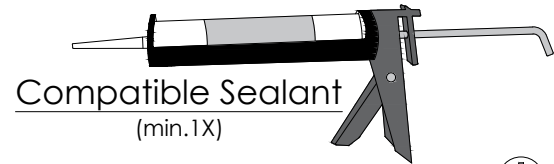

Compatible Sealant
(min.1X)

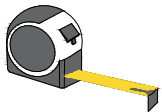

Measuring Tape
(1X)

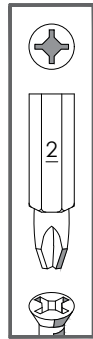

Screwdriver Bit
(1X)



Screwdriver Bit
Quadrex 6" #2 (1X)



Pencil
(1X)

08375.58.SACn1.3V : FRAME & SASH Hardware bag

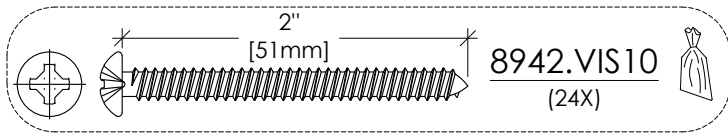

8942.VIS10
(24X)

09750.00.S8385.3V : Installation bag

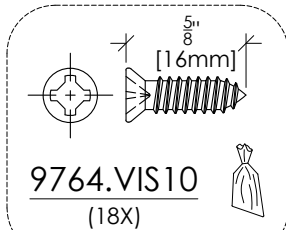

9764.VIS10
(18X)

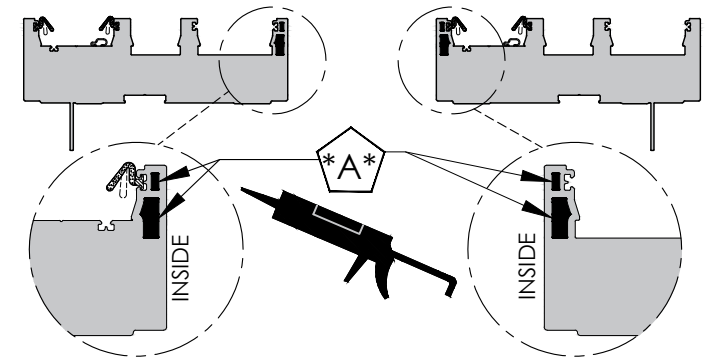
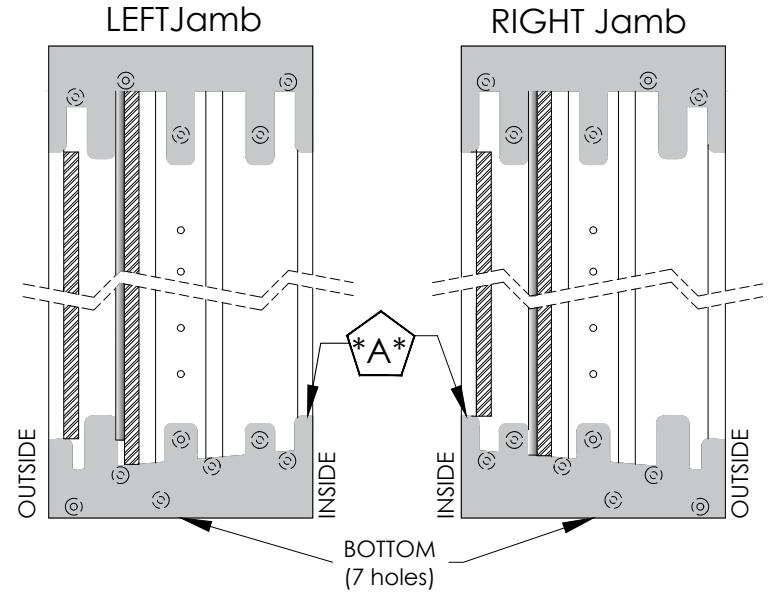
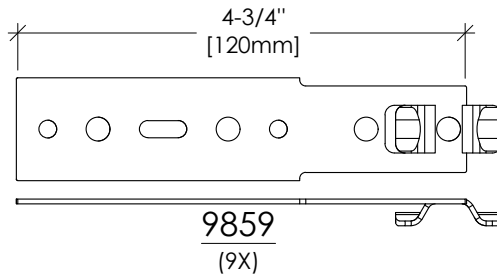

IMPORTANT:



On each jambs, make sure to fill the two (2) bottom cavities with sealant before fastening the frame. (To ensure the frame & waterbar are waterproof)



STEP:
5

(Continued) Frame Assembly

REVISION:
2021/03/10

PAGE:
P18

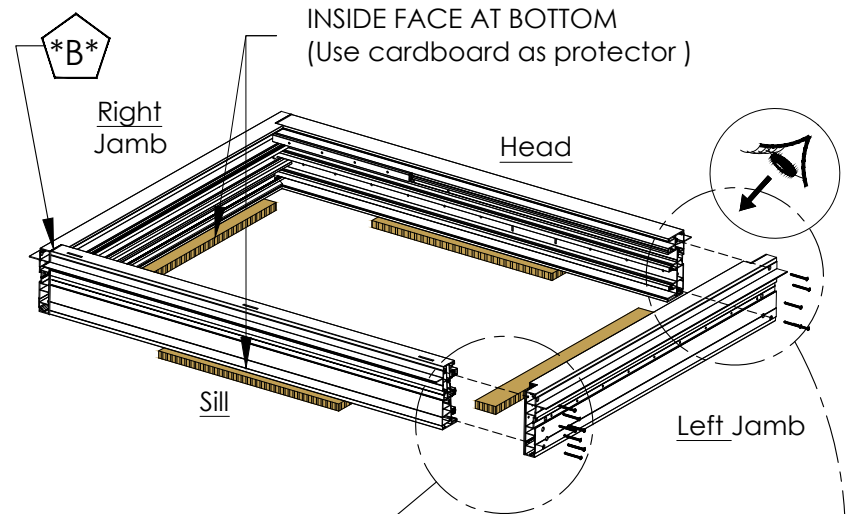
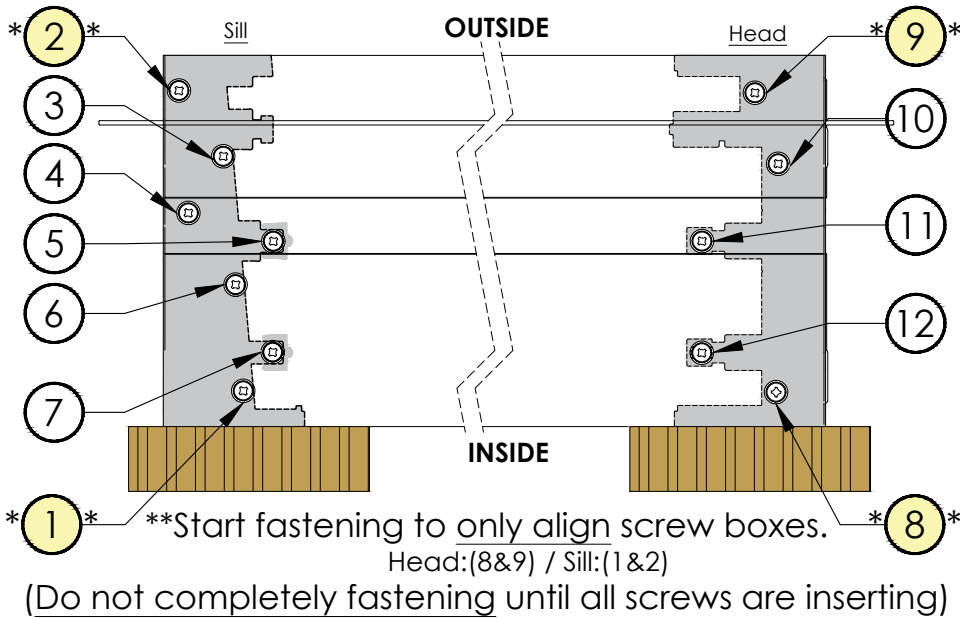

B

IMPORTANT:
Make sure all corners are square and faces are aligned when fastening.

C

IMPORTANT:
From the inside at sill, wipe off any excess sealant after fastening.

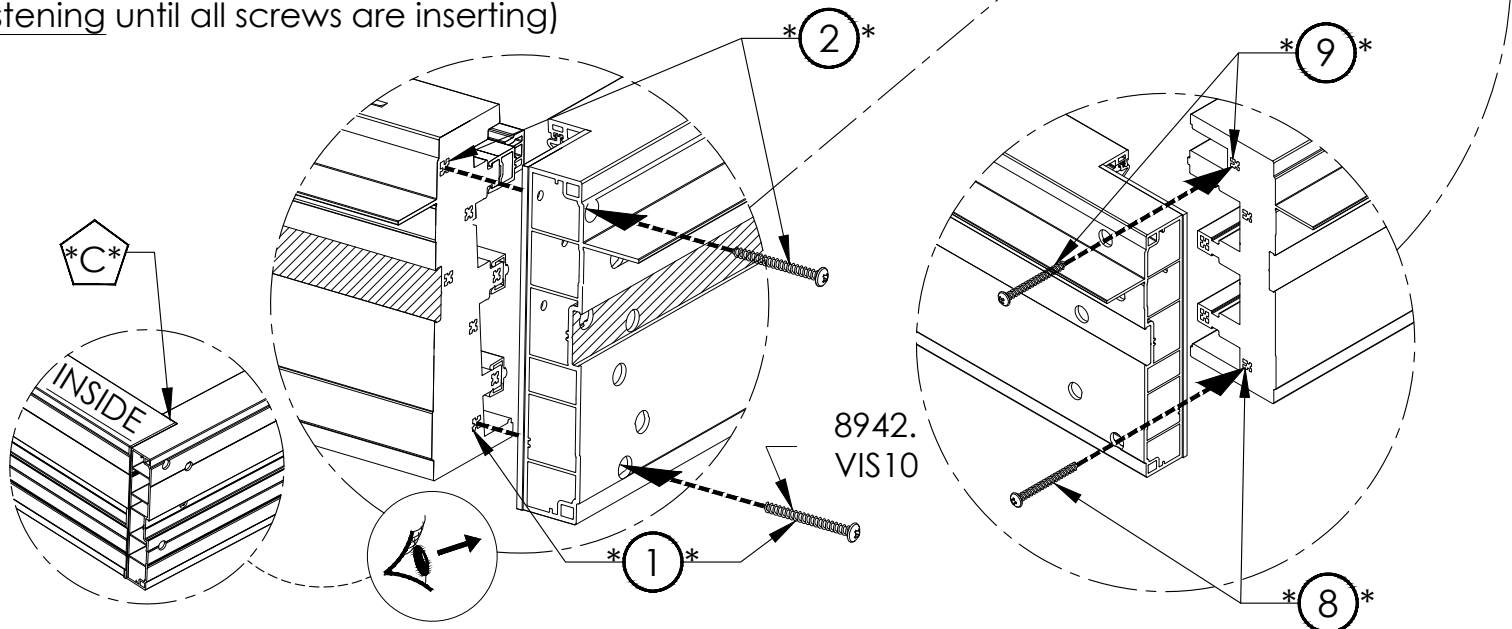



STEP:
5

(Continued) Frame Assembly

REVISION:
2021/03/10

PAGE:
P19

NOTE
US Installation W/O Nailing Fin in WOOD-Frame construction (See P15)
(Do not take care of this page for concrete application or frame with Nailing Fin)

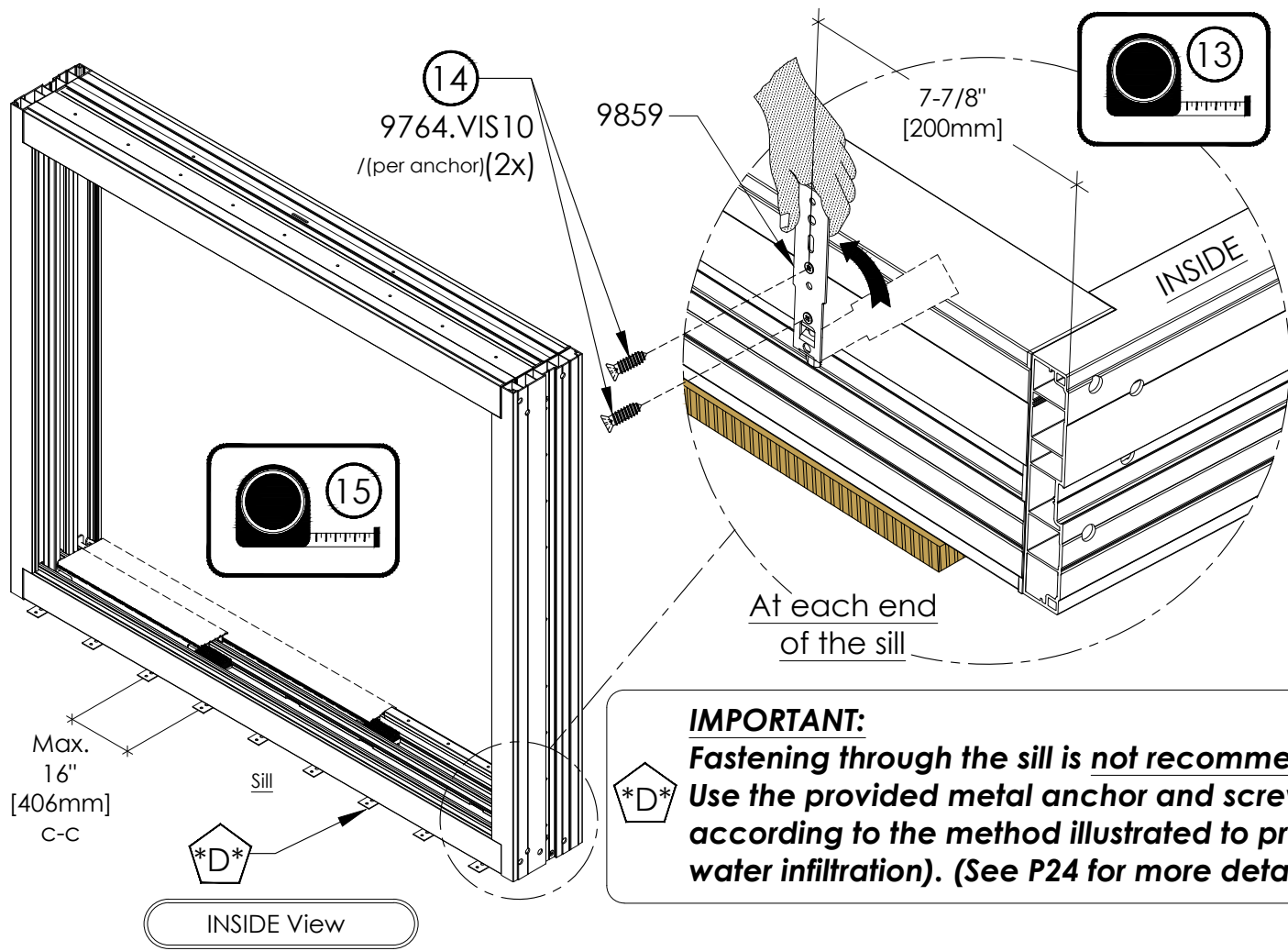

IMPORTANT:
Fastening through the sill is not recommended.
Use the provided metal anchor and screws according to the method illustrated to prevent water infiltration). (See P24 for more detail)

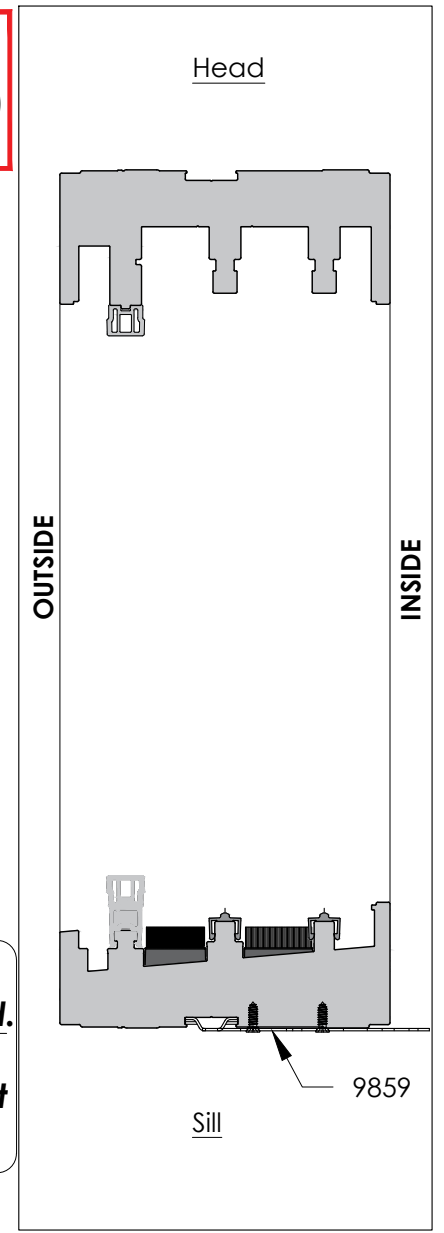



STEP:
6

Installation of the Frame

REVISION:
2021/03/10

PAGE:
P20

Tools and hardware required for this step



Impact
(1X)

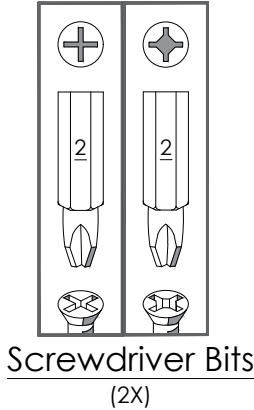

Screwdriver Bits
(2X)

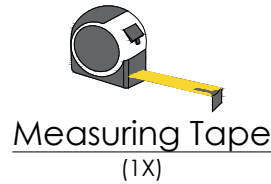

Measuring Tape
(1X)

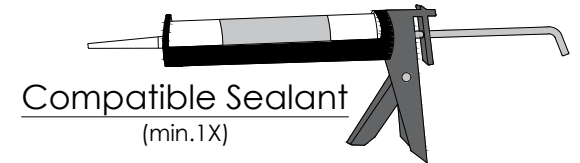

Compatible Sealant
(min.1X)



Screwdriver Bit
Quadrex 6" #2 (1X)

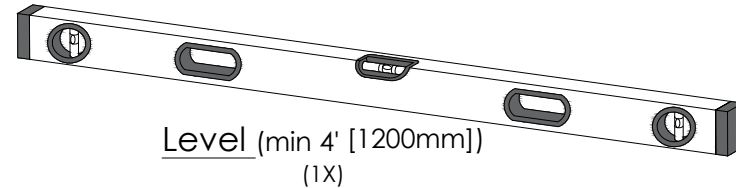

Level (min 4' [1200mm])
(1X)

09750.00.S8385.3V : Installation bag

9683.VIS10 (30X)

9759.VIS08 (9X)

9667.CAPUC (9X) *OPTION*

IMPORTANT:
Hardwares are provided for Installation in Wood-frame construction.
***Nails or Tapcon screws are NOT provided.**

Drill Bit (min.1X)

(You may need to redrill trough existing holes of jambs/head according to the dimension selected of Tapcon screws).



STEP:
6

(Continued) Installation of the Frame

REVISION:
2021/03/10

PAGE:
P21

****** CAUTION: The product must be installed in conformance with the following standards USA: AAMA 2400, AAMA 2410 and IPCB.**

****** Be sure to also follow local applicable building code requirements. ******

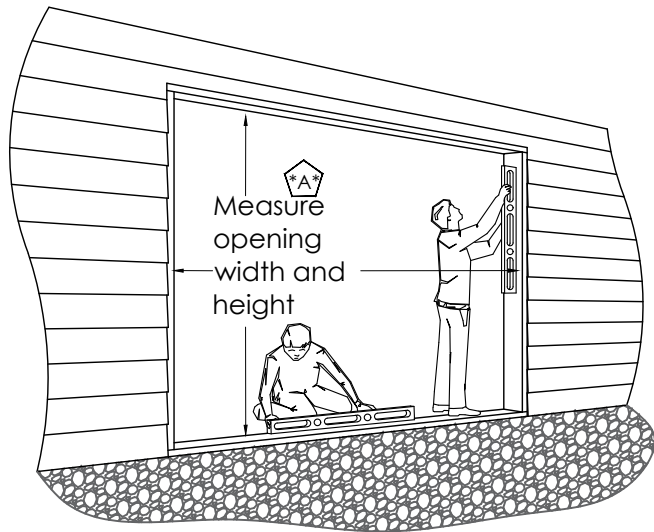

1 An improper fit will impact the performance of the door. (too narrow or too large)

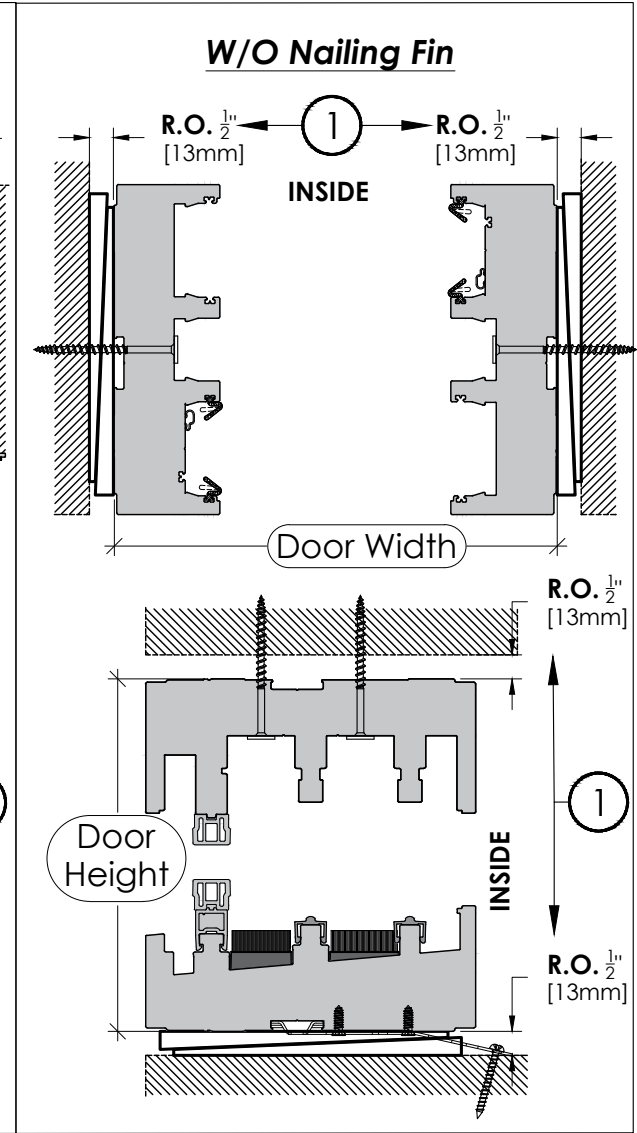
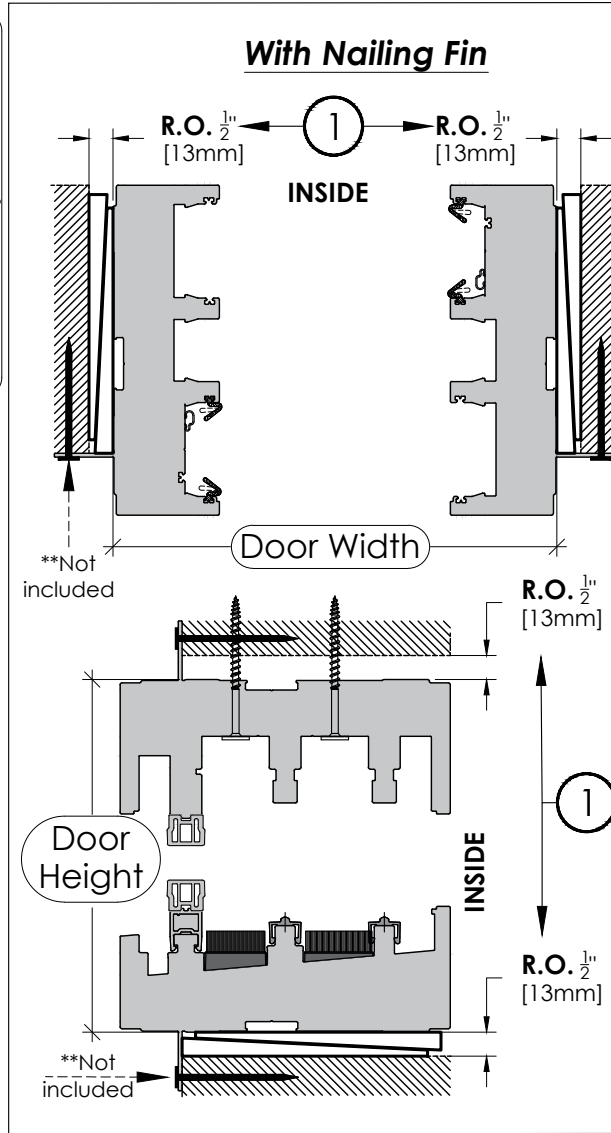

***** Note: US Installation illustrated*****
(Concrete application not illustrated: R.O. = $\frac{1}{2}$ " [13mm] all around)



(Continued) Installation of the Frame

OUTSIDE View

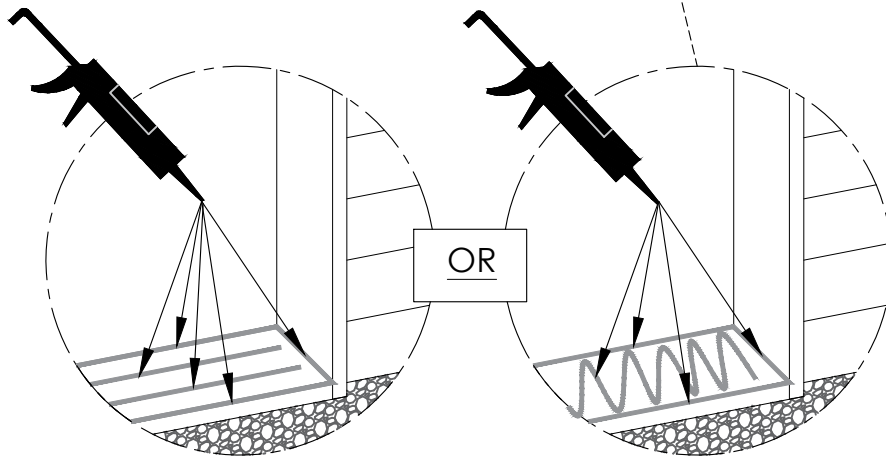
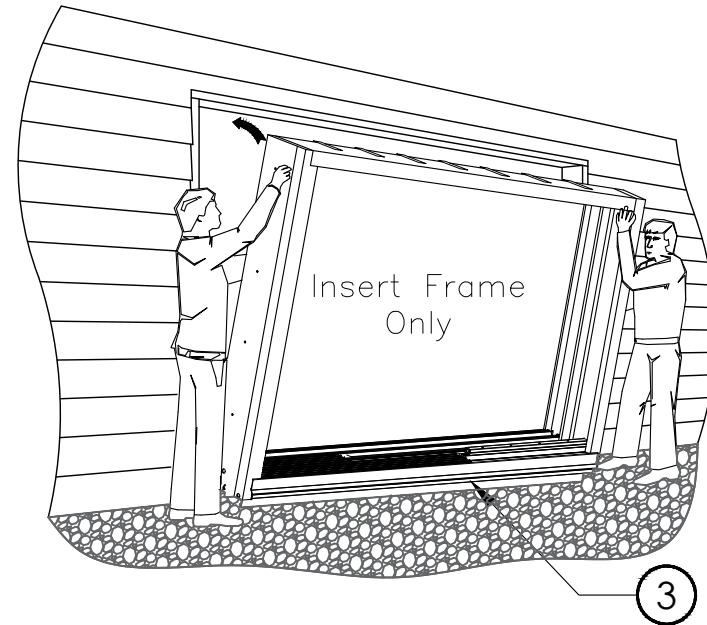
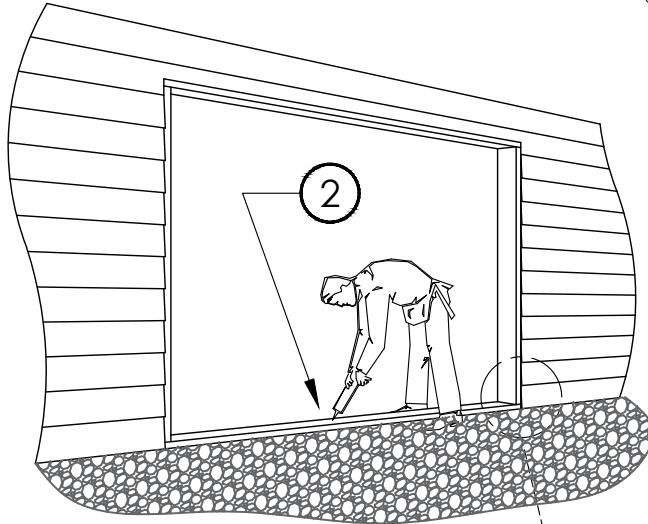
Insert frame in the Rough Opening:

- 1) Apply generous bead of good quality sealant all along the sill.
(Min Sealant bead = $\frac{5}{8}$ " [15mm]).
- 2) Install the door frame in the opening, sill first.
***Make sure that the sealant joint is continuous and sufficient between the door sill and the floor.



STEP:
6

(Continued) Installation of the Frame

REVISION:
2021/03/10

PAGE:
P23

A **ATTENTION:**
Improper shimming will bow the jambs.
Use Shims below jambs, and at each anchoring point on jambs and sill.
Do not use shims at head.
Make sure jambs are straight for optimal performance.

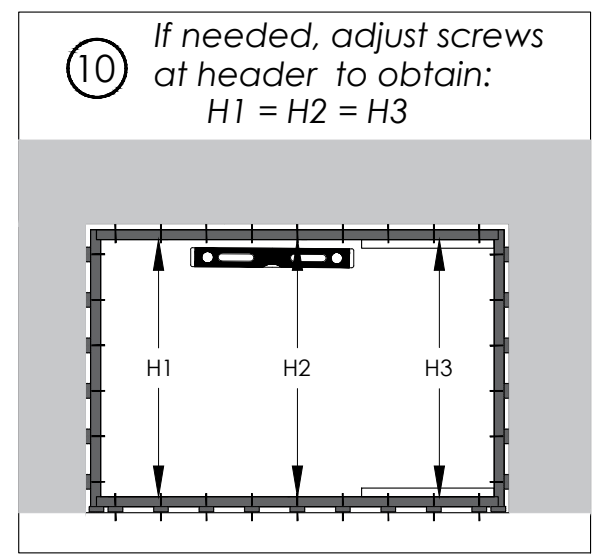
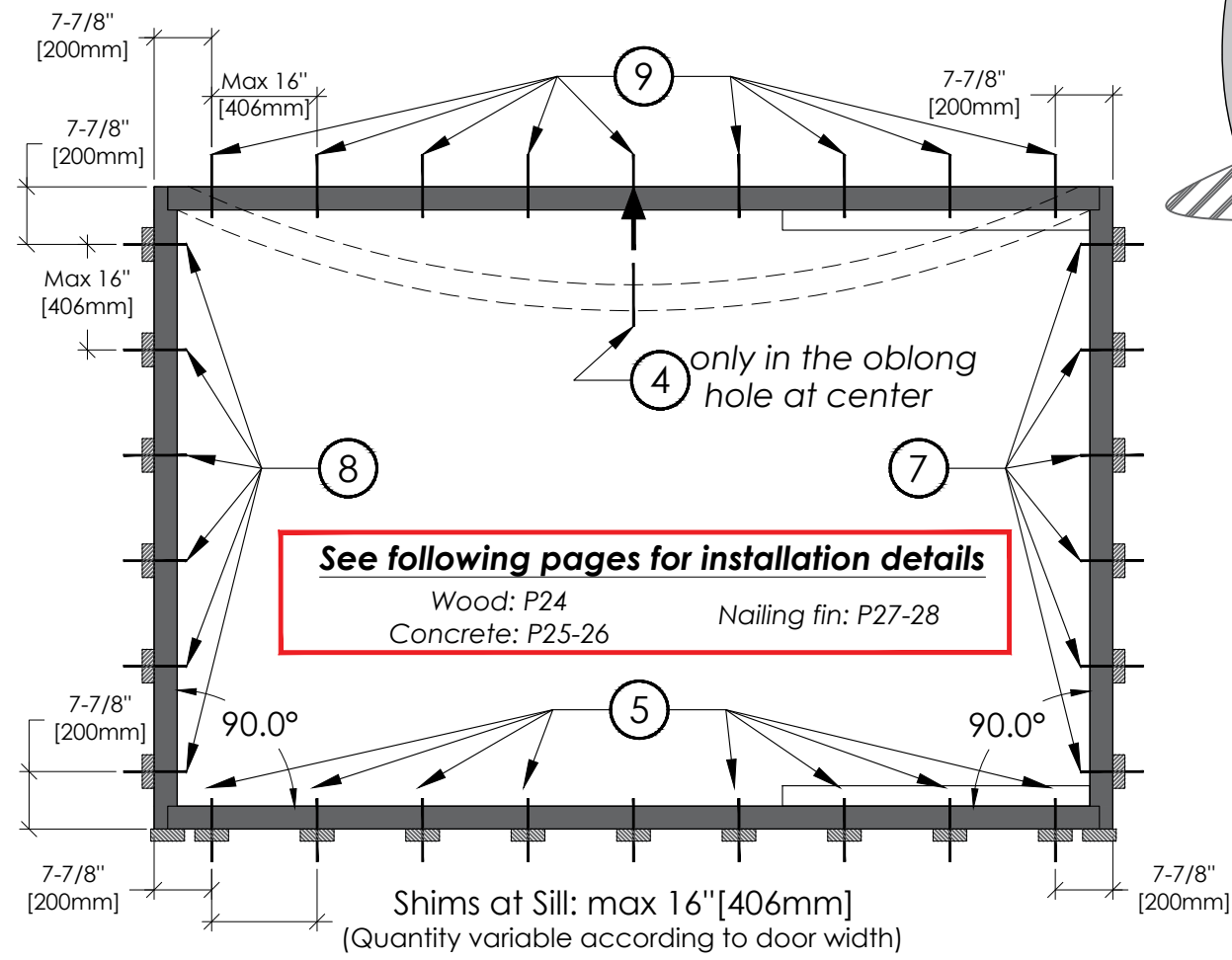
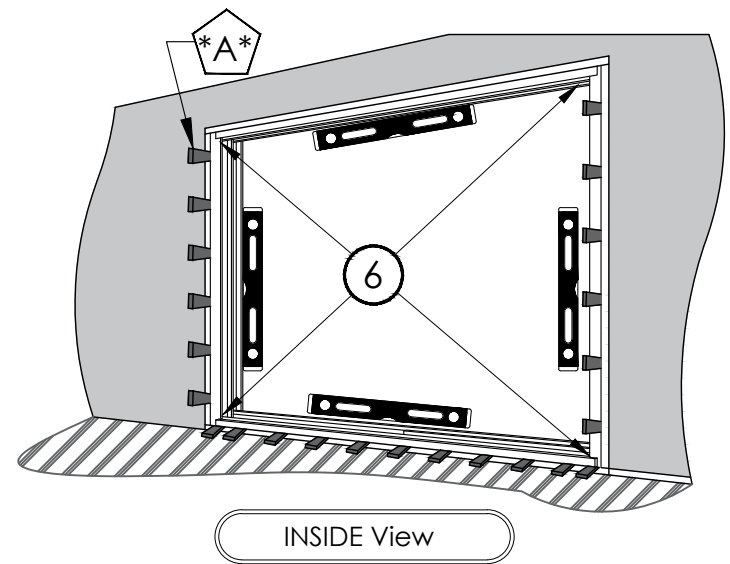



STEP:
6

(Continued) Installation of the Frame

REVISION:
2021/03/10

PAGE:
P24

WOOD FRAME
*****STRONGLY RECOMMENDED*****

Do not use shims at the header.
A gap is necessary for building settlement.

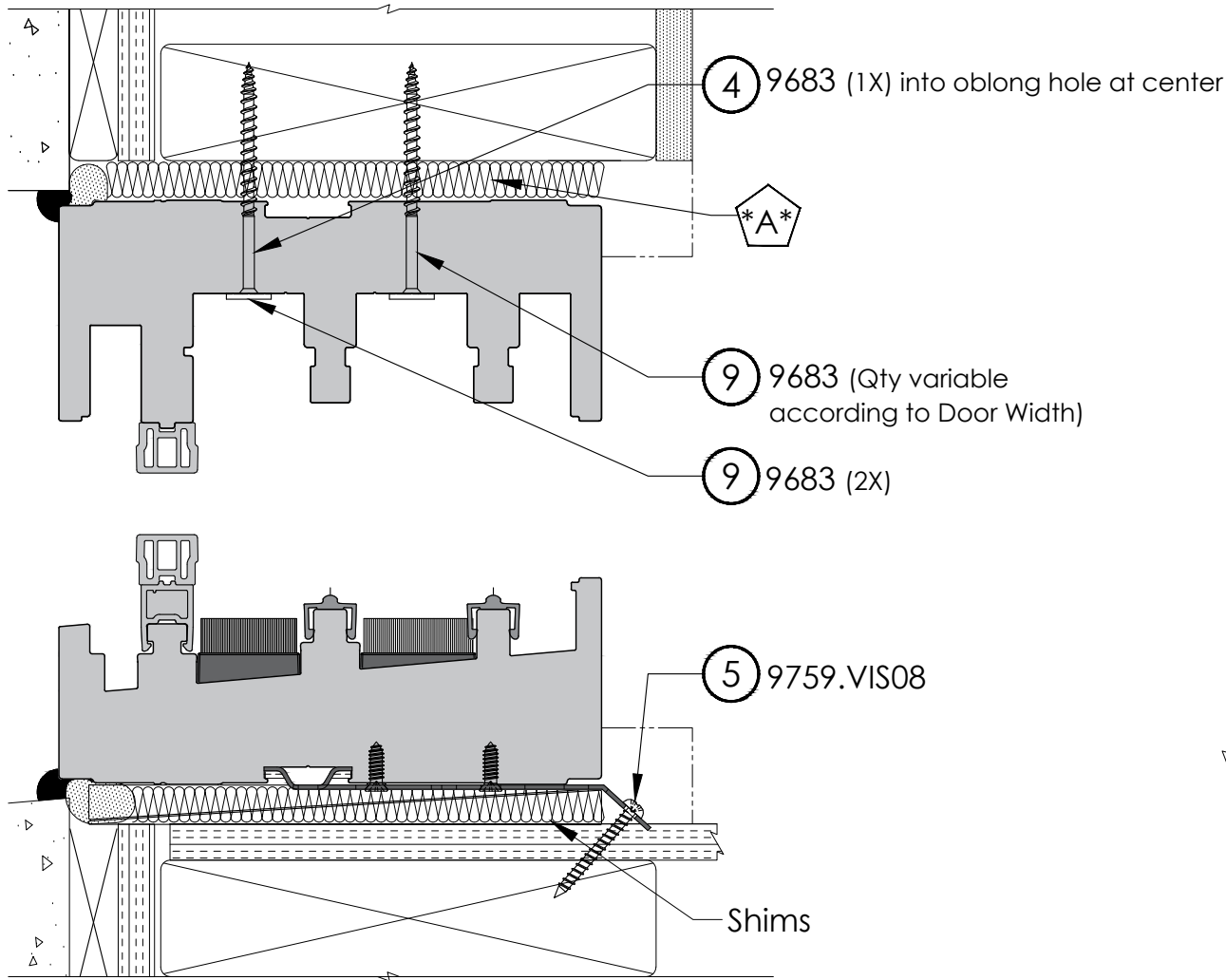

Left Jamb illustrated, Right required

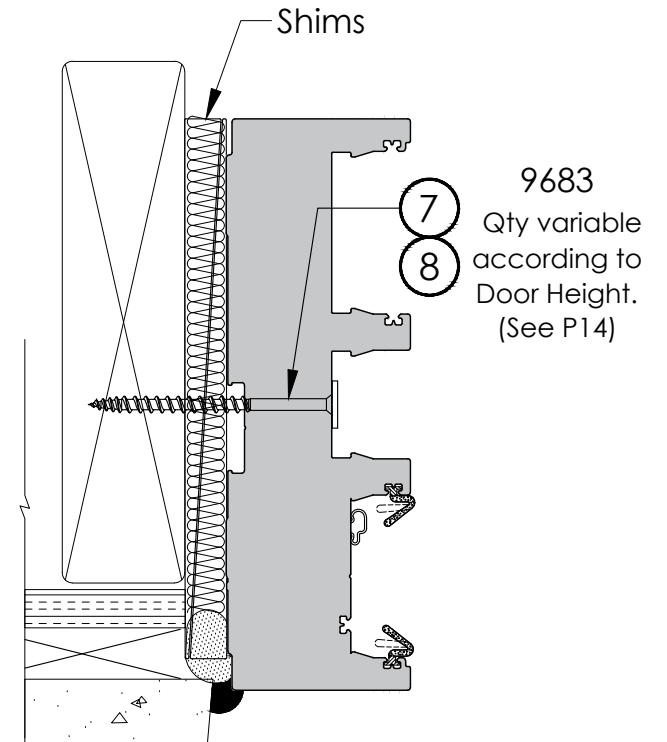



STEP:
6

(Continued) Installation of the Frame

REVISION:
2021/03/10

PAGE:
P25

A Do not use shims at the header.
A gap is necessary for building settlement.

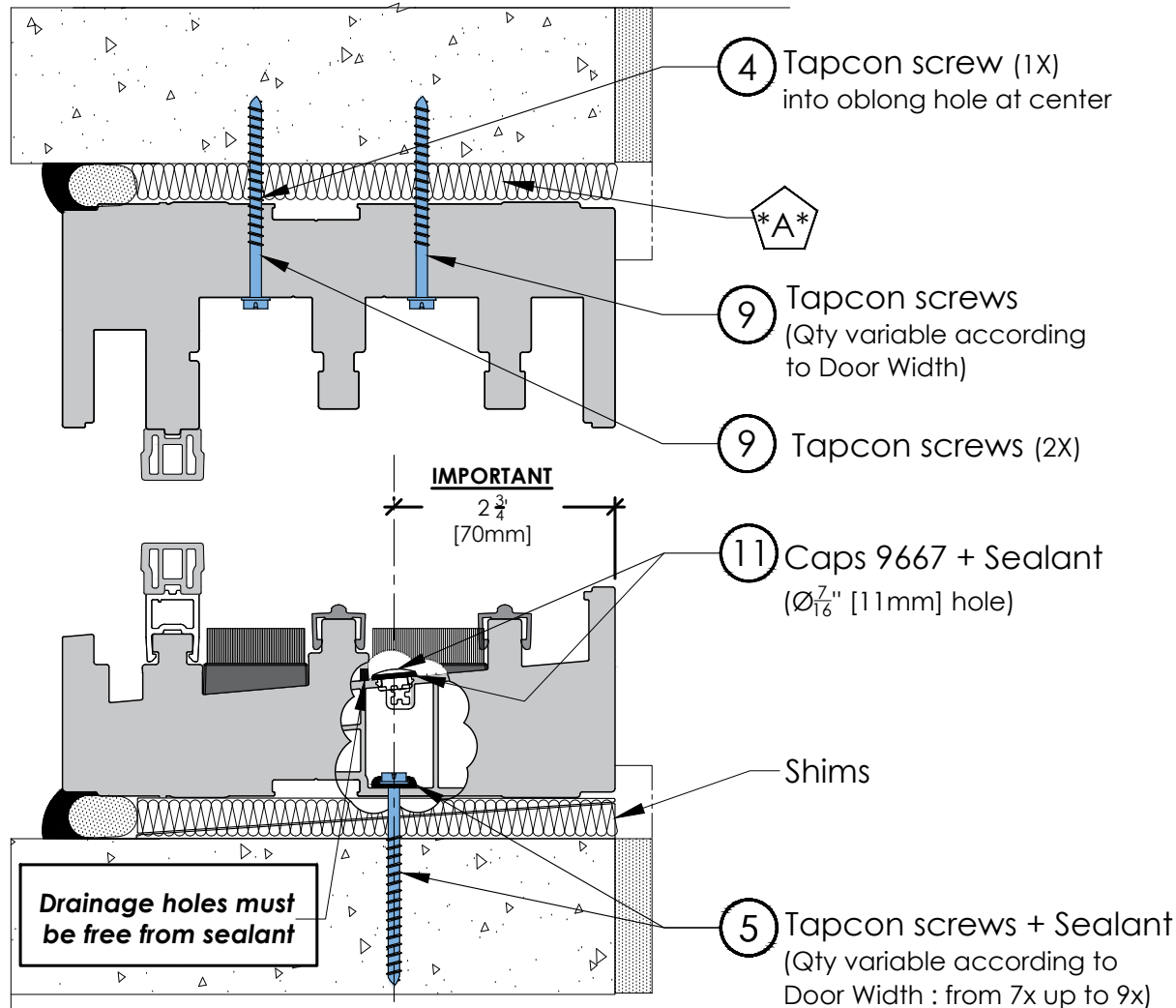

CONCRETE APPLICATION
- FOR INFORMATION ONLY -

Tapcon screws are not included

***According to dimension of tapcon screws, enlarge existing holes if needed.

Left Jamb illustrated, Right required

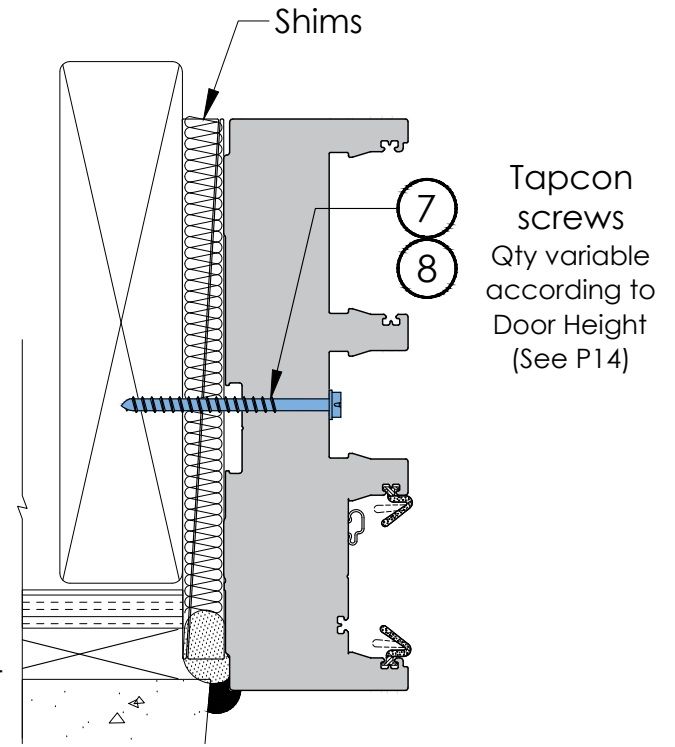



(Continued) Installation of the Frame

**Sill Installation Detail : (5) + (11) : -Make sure sill is level and plumb before fastening.
-Repeat a-b-c-d for every drilled holes in the sill.**

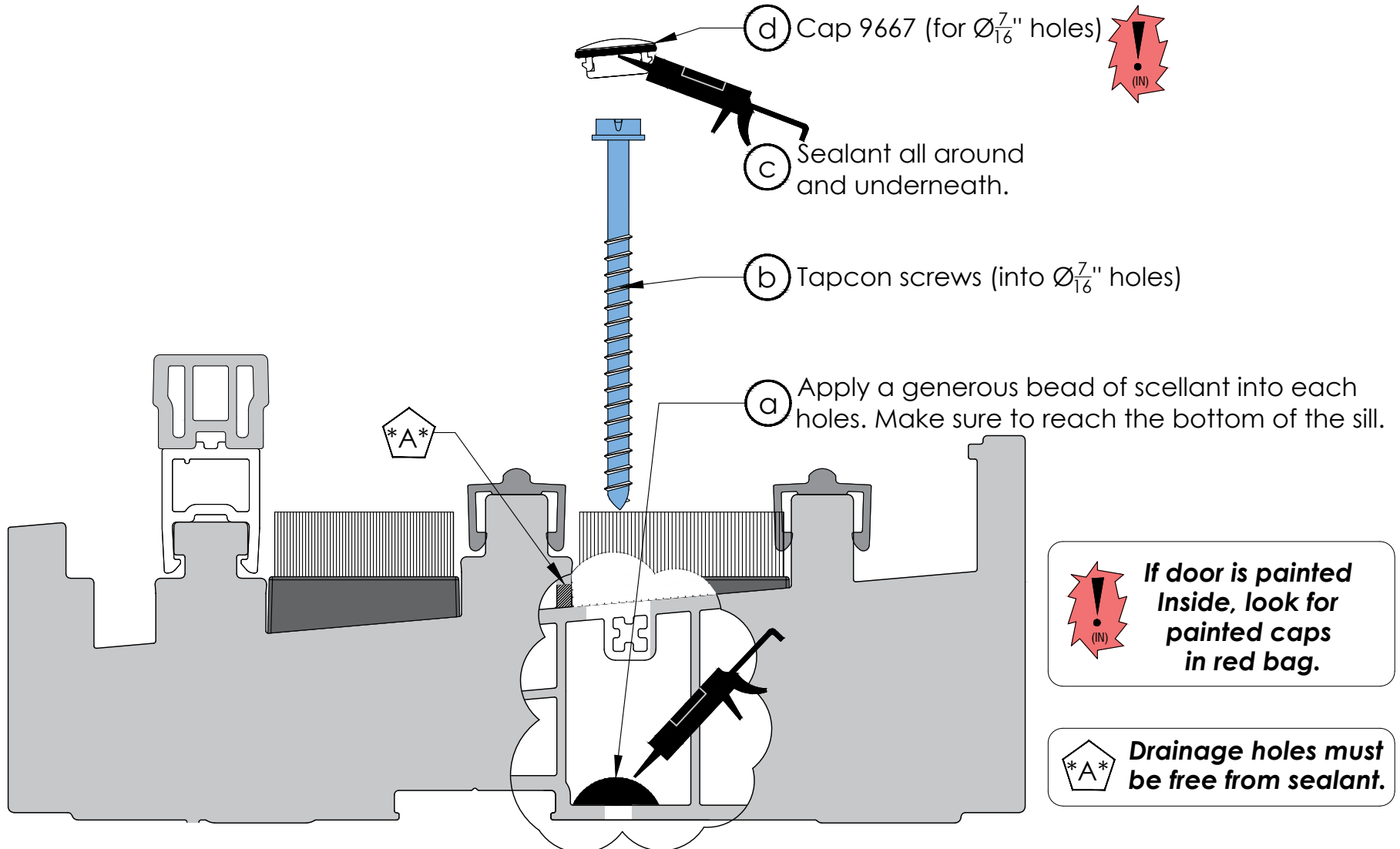



STEP:
6

(Continued) Installation of the Frame

REVISION:
2021/03/10

PAGE:
P27

A
Do not use shims at the header.
A gap is necessary for building settlement.
9683 (6X) are recommended in existing holes to support head and further adjustment.

With Nailing Fin
- FOR INFORMATION ONLY -
Nails are not included:
B Positioned at $7\frac{7}{8}$ " [200mm] from each corner and spaced every 2 slots (about $7\frac{1}{4}$ " [184mm]).

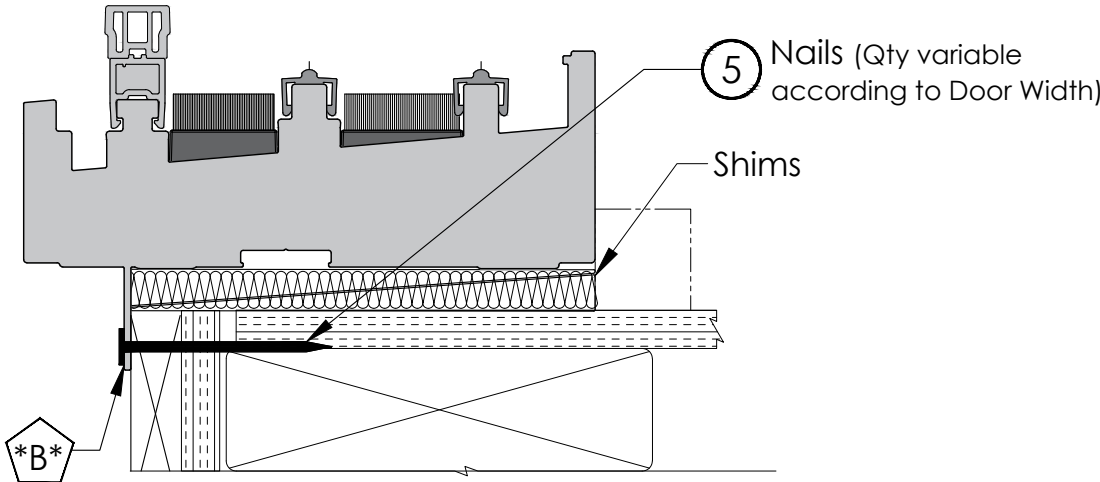
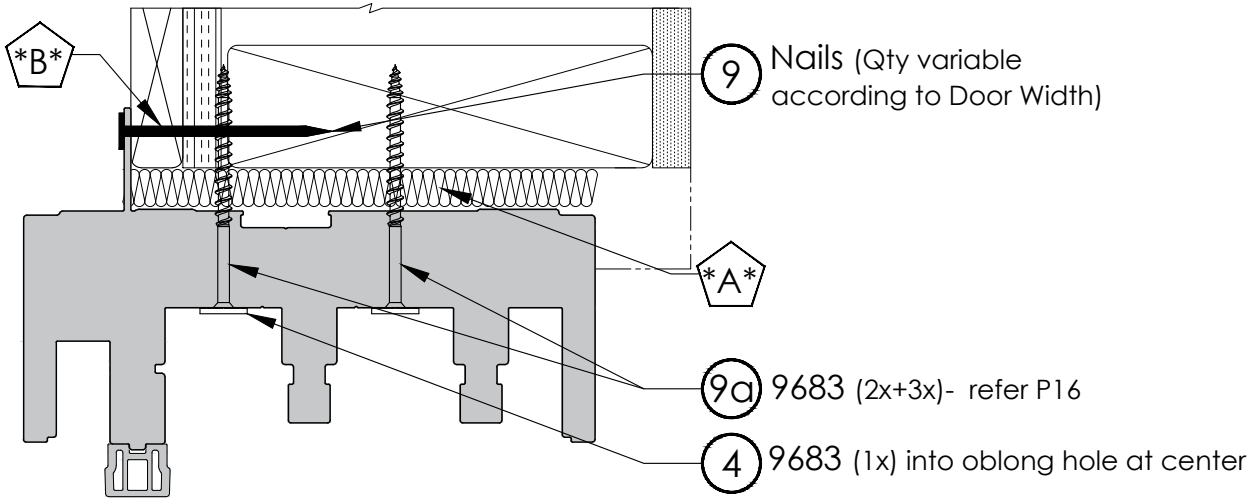

Left Jamb illustrated, Right required

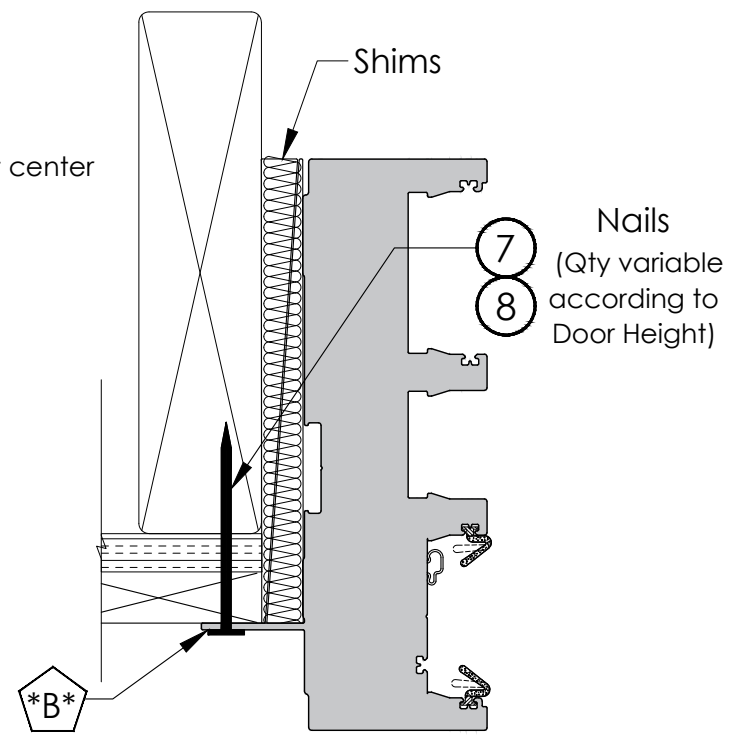



(Continued) Installation of the Frame

Please refer to the standards and codes for proper building envelope connexions.

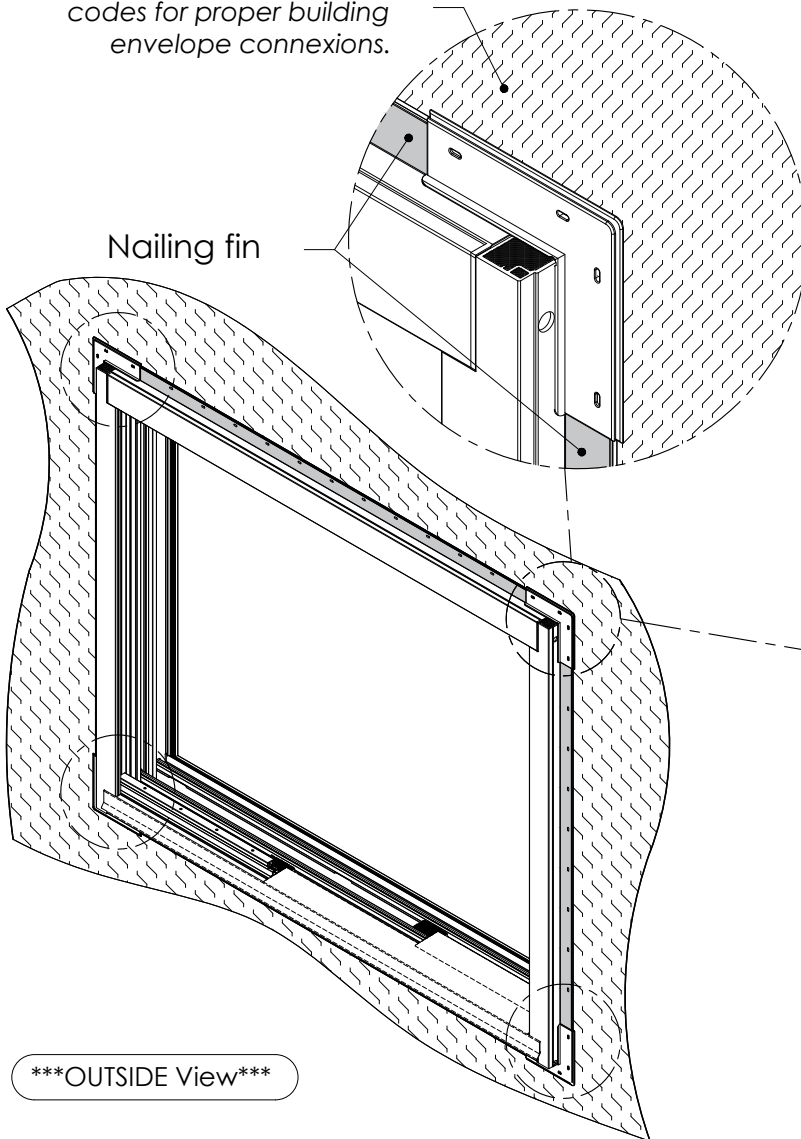

OUTSIDE View

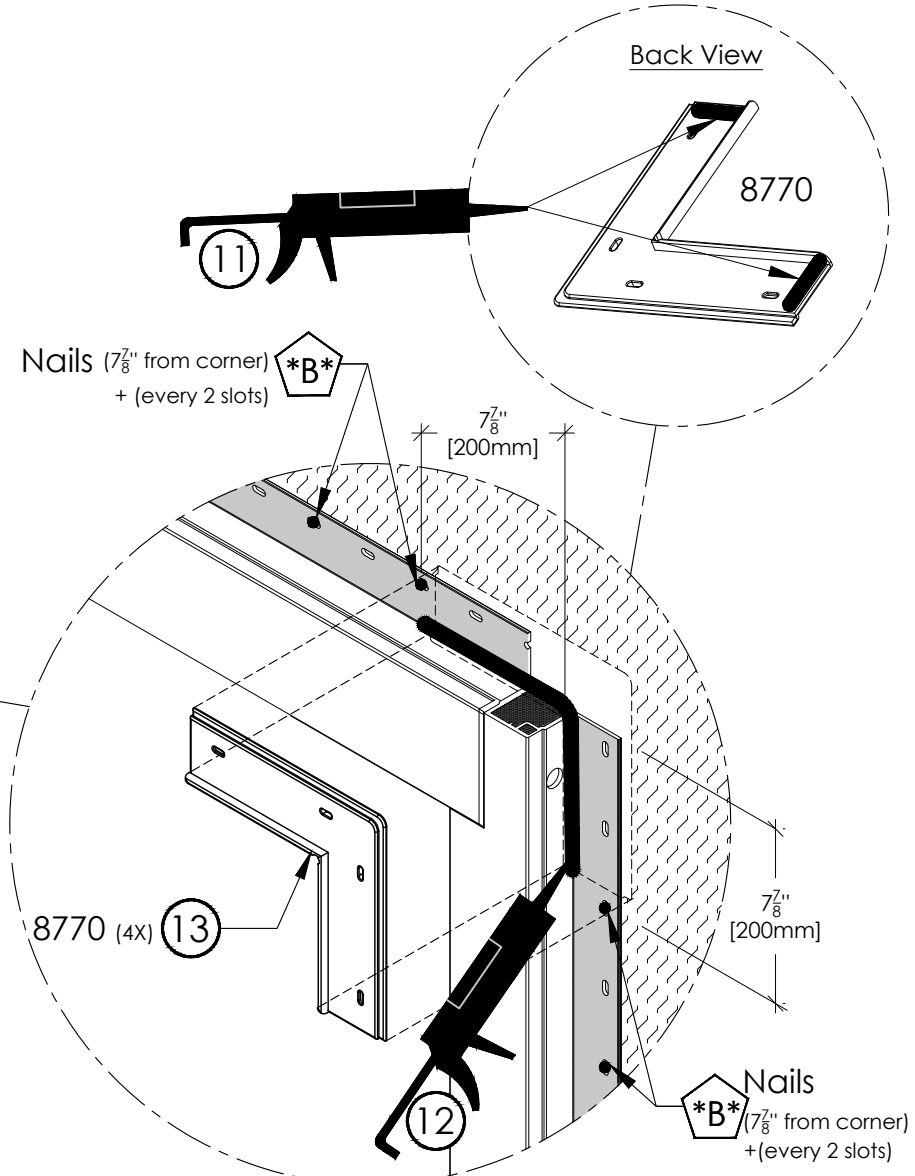



STEP:
7

Installation of the Fixed Sash

REVISION:
2021/03/10

PAGE:
P29

Tools and components required for this step



Impact
(1X)

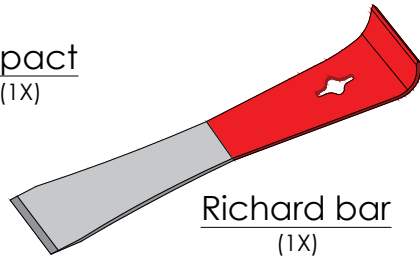

Richard bar
(1X)

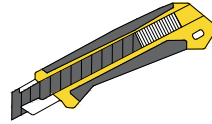

Knife
(1X)

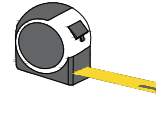

Measuring Tape
(1X)

08375.58.SACn1.3V : FRAME & SASH Hardware bag

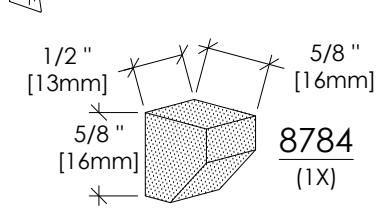

8784
(1X)

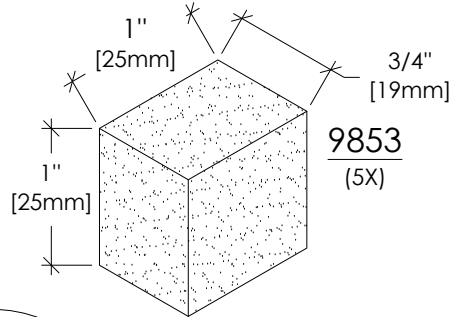

9853
(5X)

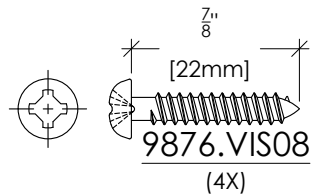

9876.VIS08
(4X)

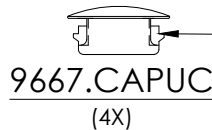

9667.CAPUC
(4X)

! *If painted door (Inside), rather use parts in a red bag in the Sash box.*

08385.54.EXTRA.3V: EXTRA Bag - IMPACT

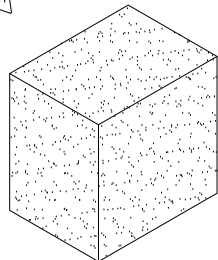

9853
(2X) - White

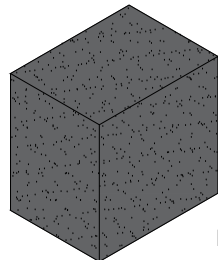

9853
(2X) - Black
OPTION
Painted Door only
(OUTSIDE)



Screwdriver Bit
Quadrex 6" #2 (1X)



Rubber Mallet
(1X)

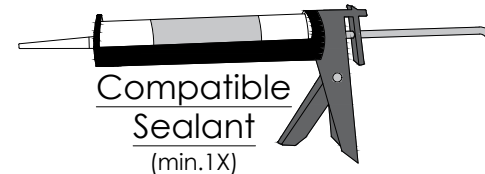

Compatible Sealant
(min.1X)

Invisible Lubricant Silicone
(1X)

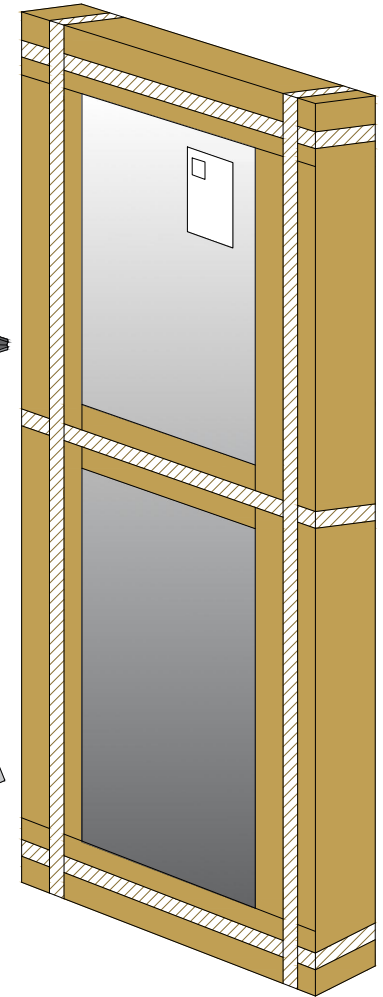
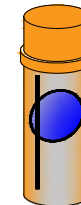

FIXED Sash Box
(1X)



(Continued) Installation of the Fixed Sash

REVISION:
2021/03/10

PAGE:
P30

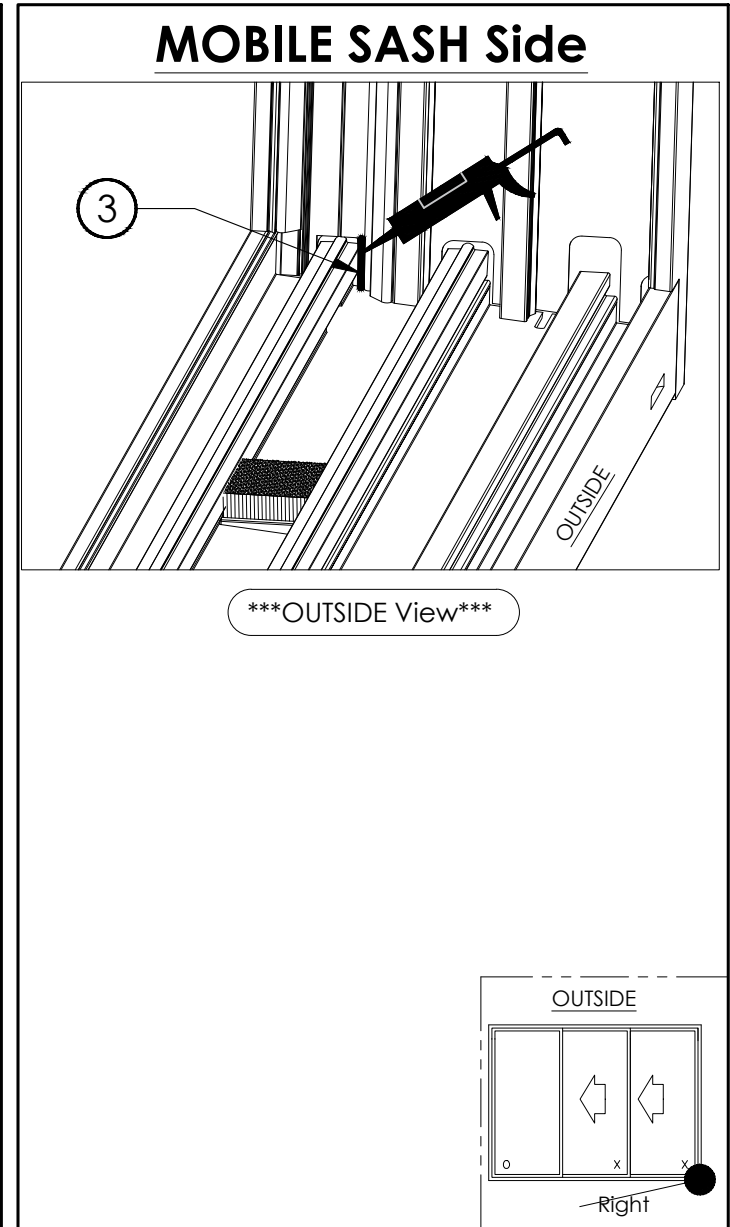
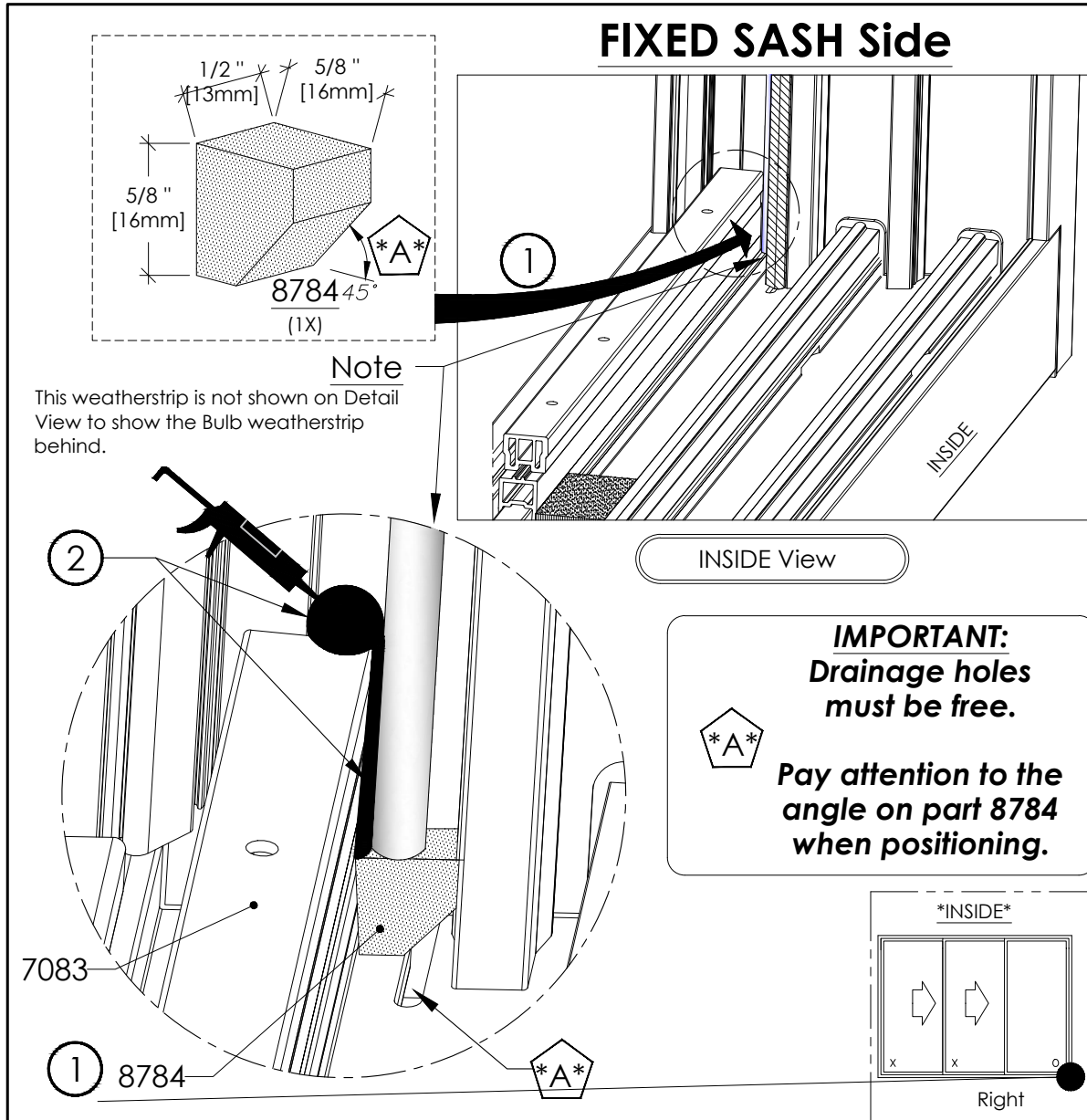



STEP:
7

(Continued) Installation of the Fixed Sash

REVISION:
2021/03/10

PAGE:
P31

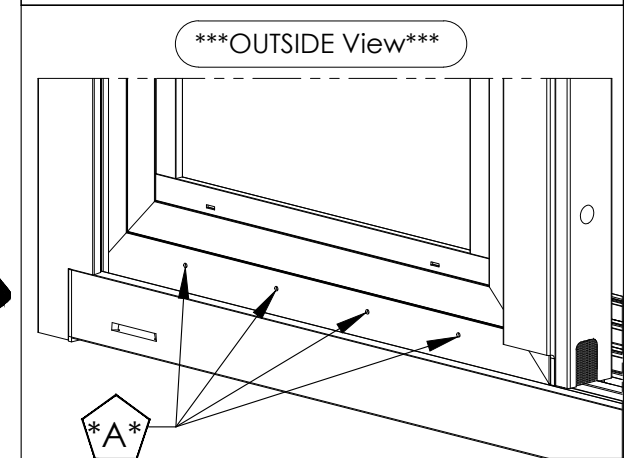
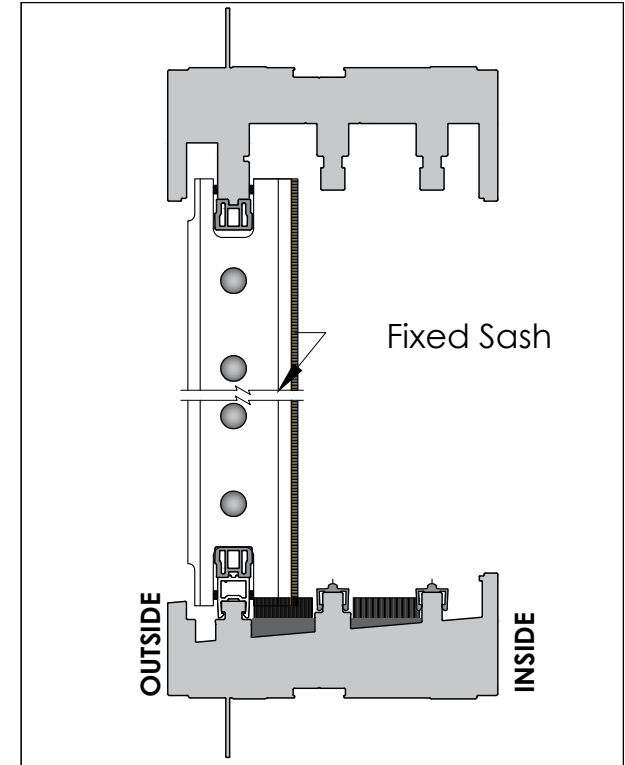
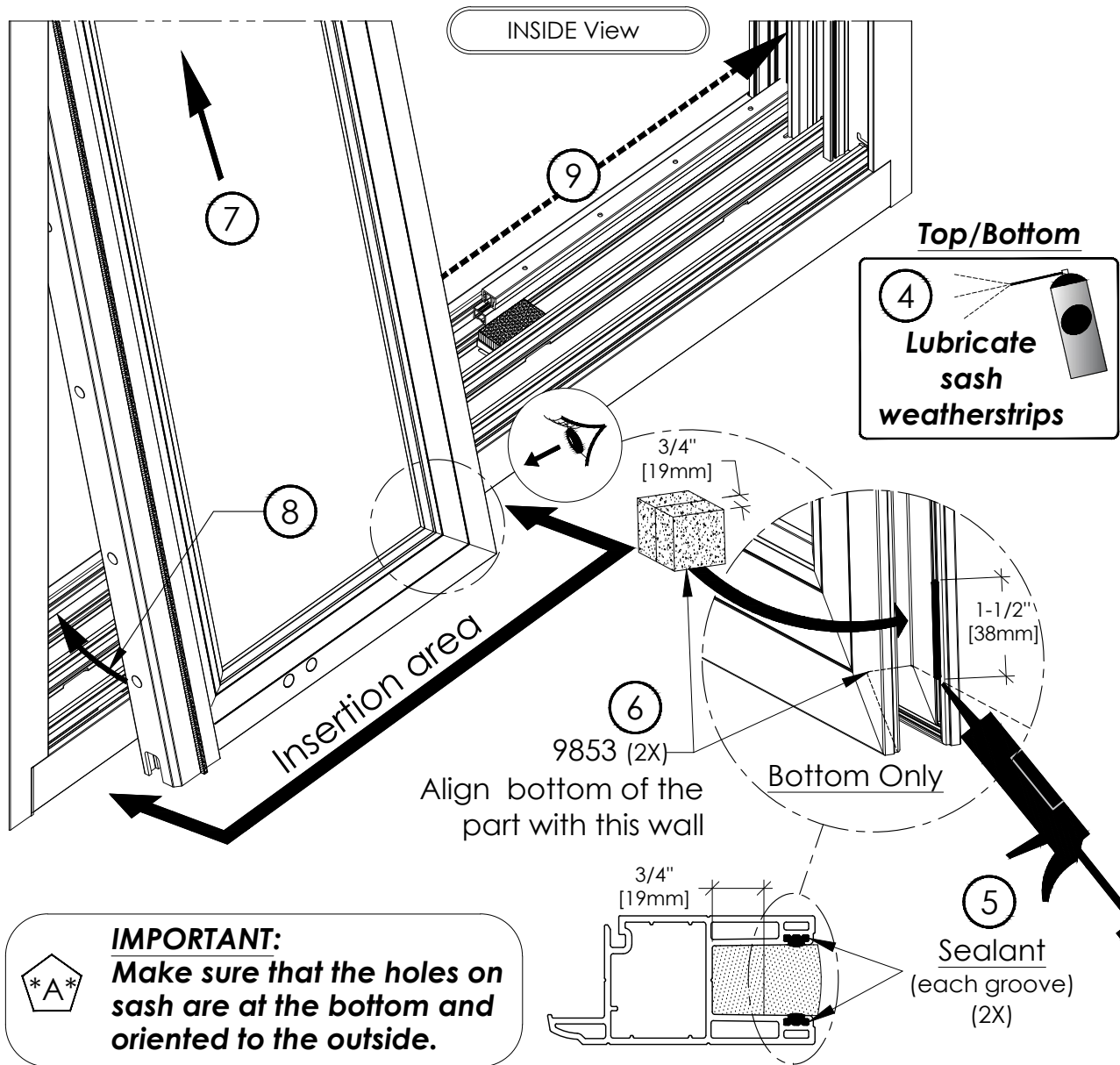

A

IMPORTANT:
Make sure that the holes on sash are at the bottom and oriented to the outside.





(Continued) Installation of the Fixed Sash

REVISION:
2021/03/10

PAGE:
P32

IMPORTANT:
 **Check the squaring of the sash before fastening. (If necessary, straighten the head with the adjustment screws 9683 - see step 6).**

The dimension D1 and D2 must be equivalent.
(near the jamb and near the meeting rail)

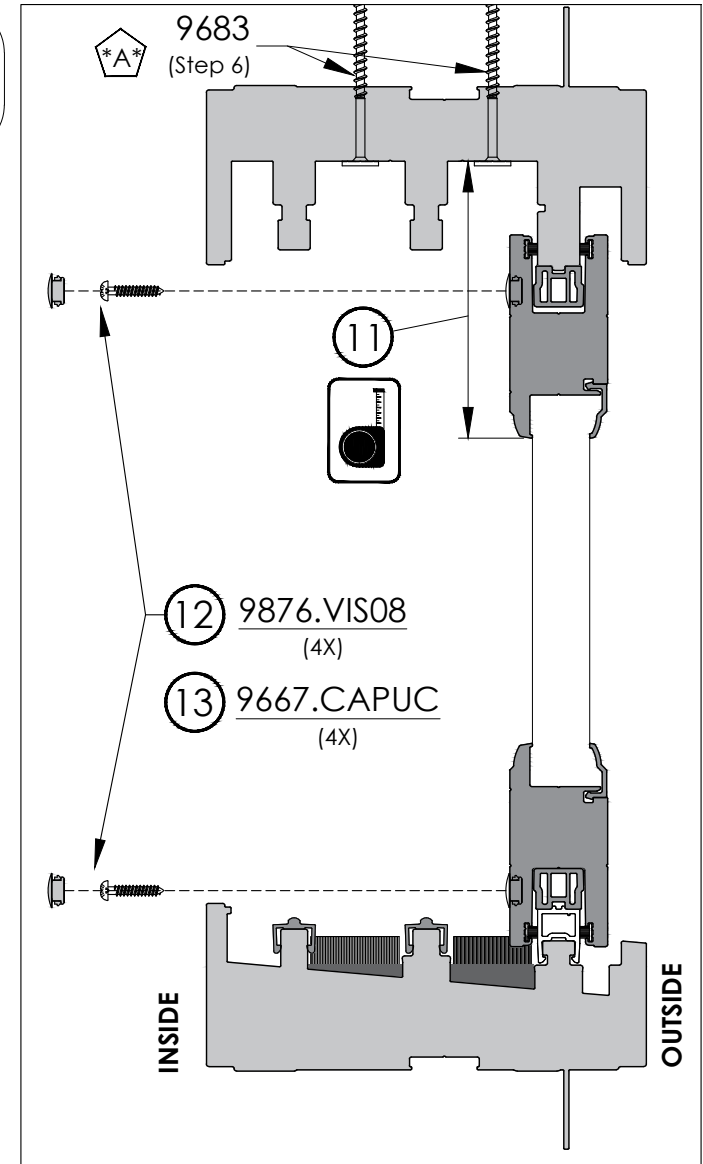
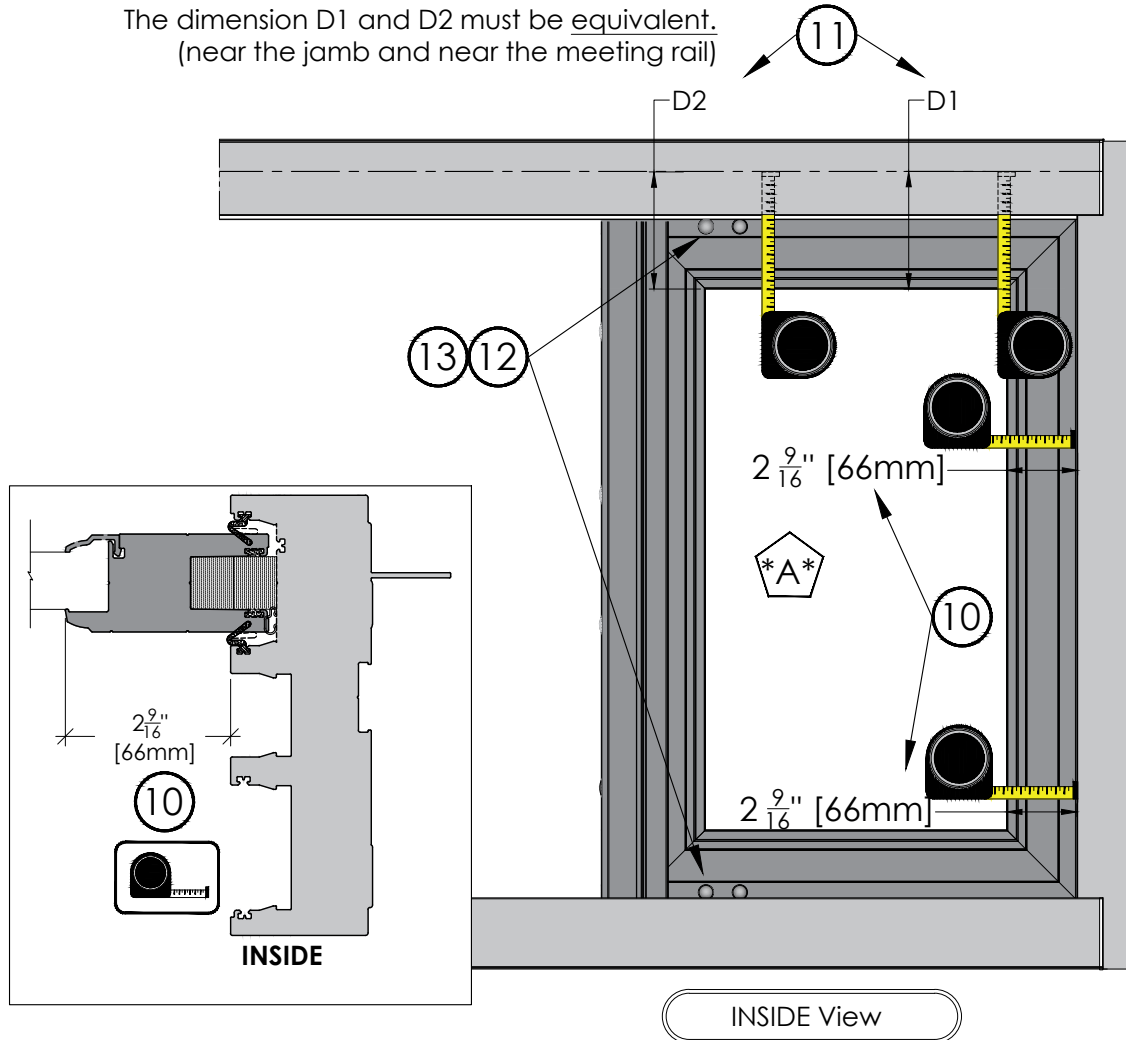



STEP:
7

(Continued) Installation of the Fixed Sash

REVISION:
2021/03/10

PAGE:
P33

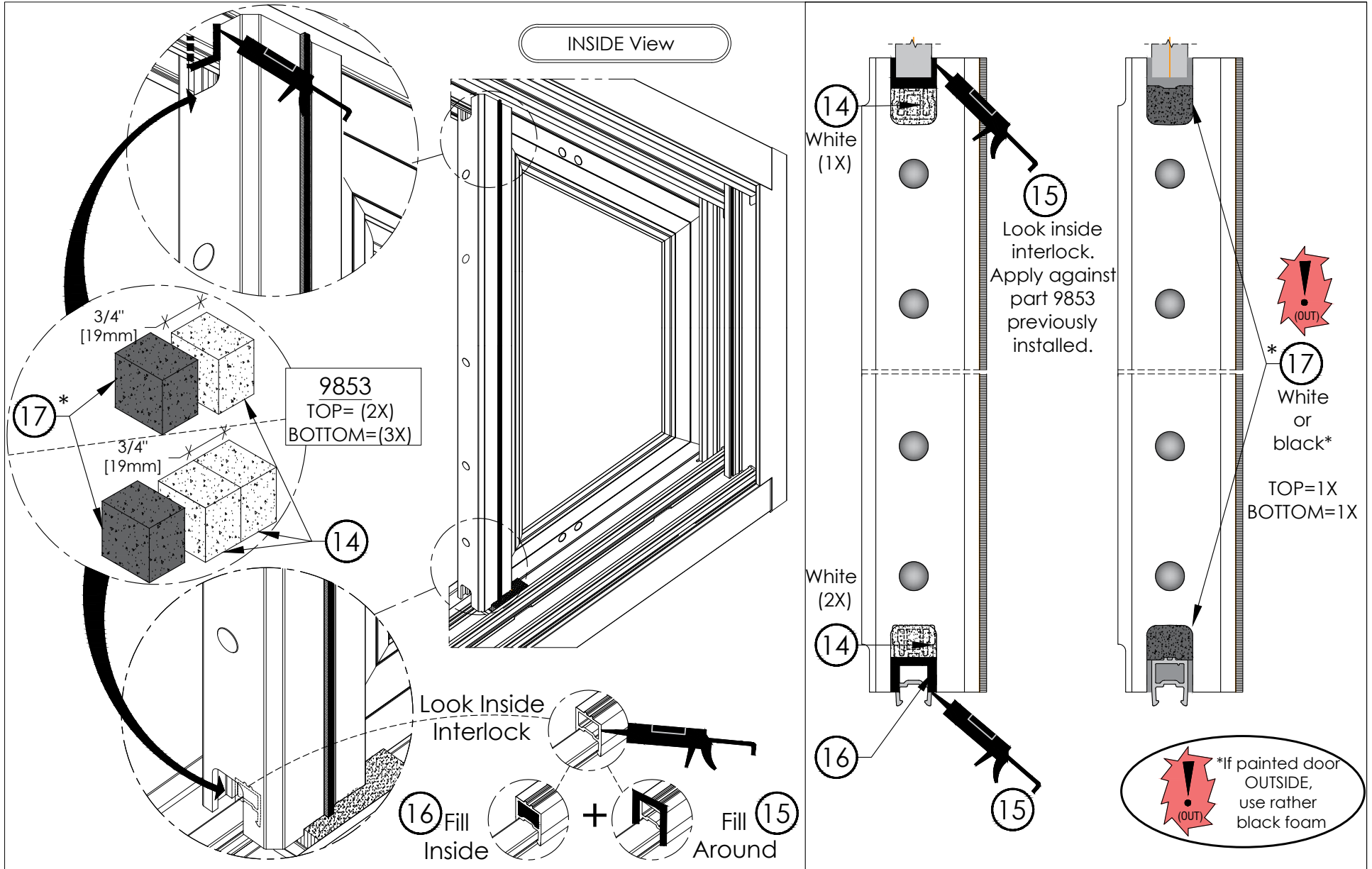



STEP:
8

Installation of Central Sash & Head Tracks #8321

REVISION:
2021/03/10

PAGE:
P34

Tools and components required for this step

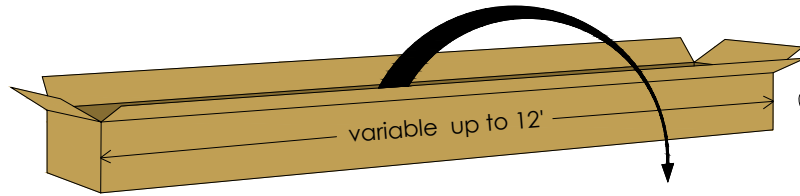

8321
(2X)



Impact
(1X)

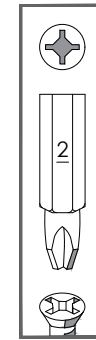

Screwdriver Bit
(1X)

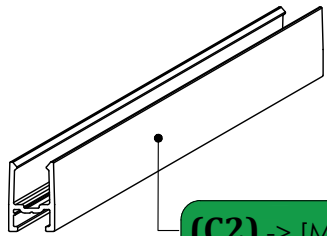

(C2) -> [M]

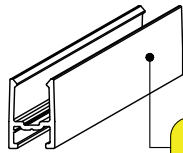

(C1) -> [F]

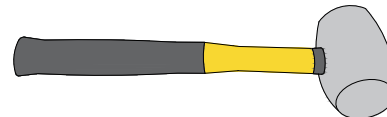

Rubber Mallet
(1X)

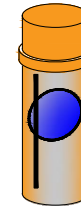

Invisible Lubricant
Silicone
(1X)



08375.58.SACn1.3V : FRAME & SASH Hardware bag

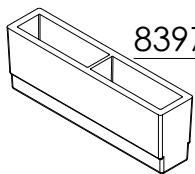

8397.58.ANCVS
(1X)

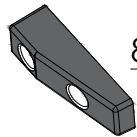

8389.ARREV
(1X)



1-1/4"
[32mm]

8941.VIS08
(2X)
BLACK

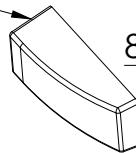

8389.CAPEV
(1X)

*If painted door (IN=Inside),
rather use parts on red bag in
Sill box.*

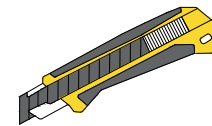

Knife
(1X)

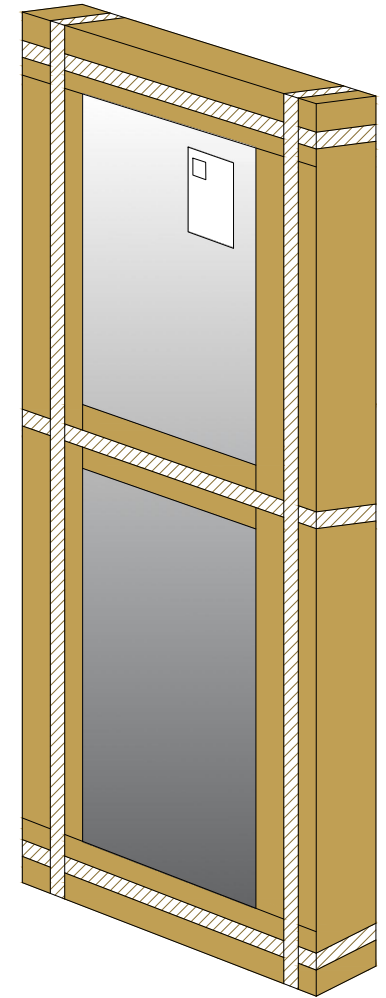

CENTRAL Sash Box
(1X)



STEP:
8

(Continued) Installation of Central Sash & Head Tracks #8321

REVISION:
2021/03/10

PAGE:
P35

ATTENTION:
A **MUST BE DONE BEFORE
INSERTING SASH IN FRAME.**

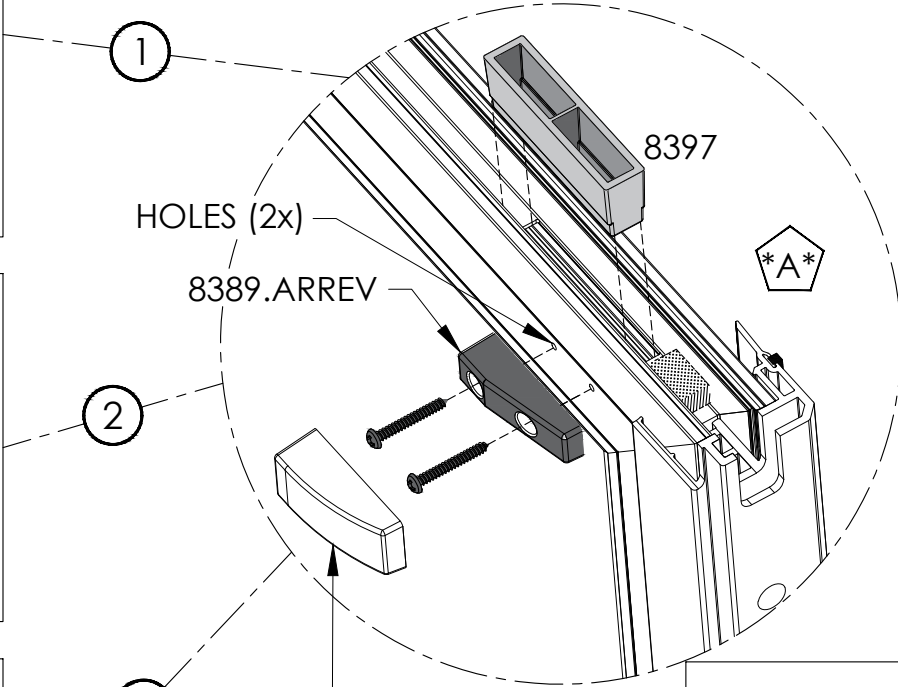
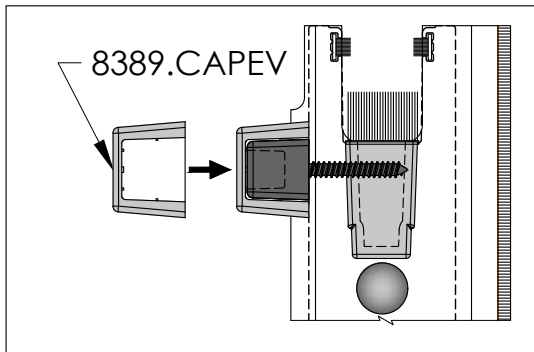
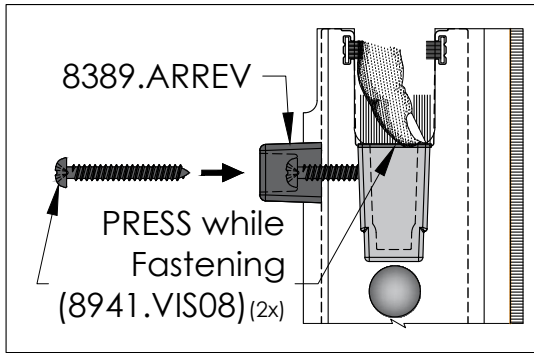
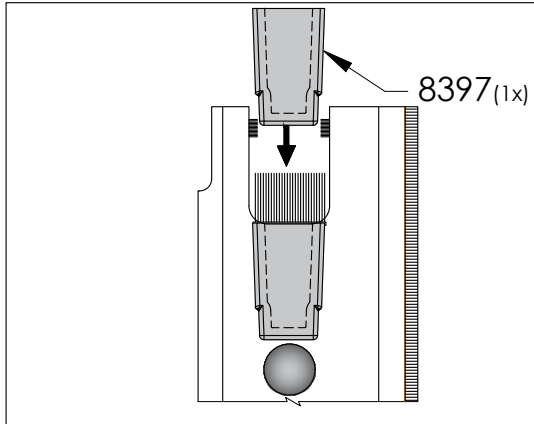

INSIDE View

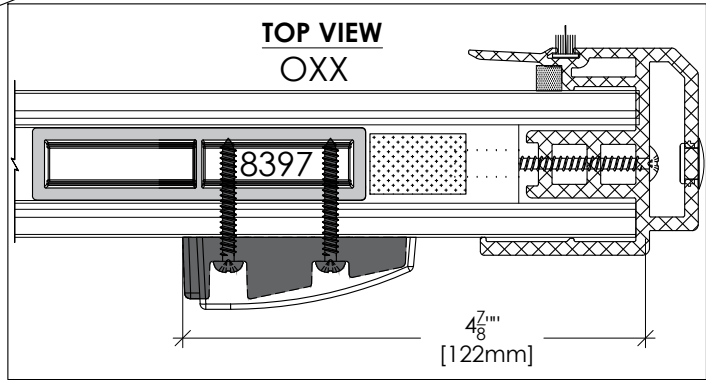



STEP:
8

(Continued) Installation of Central Sash & Head Tracks #8321

REVISION:
2021/03/10

PAGE:
P36

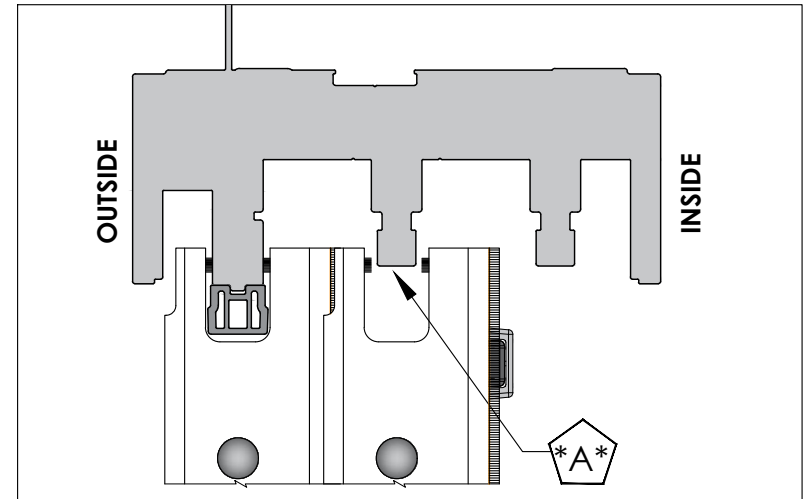
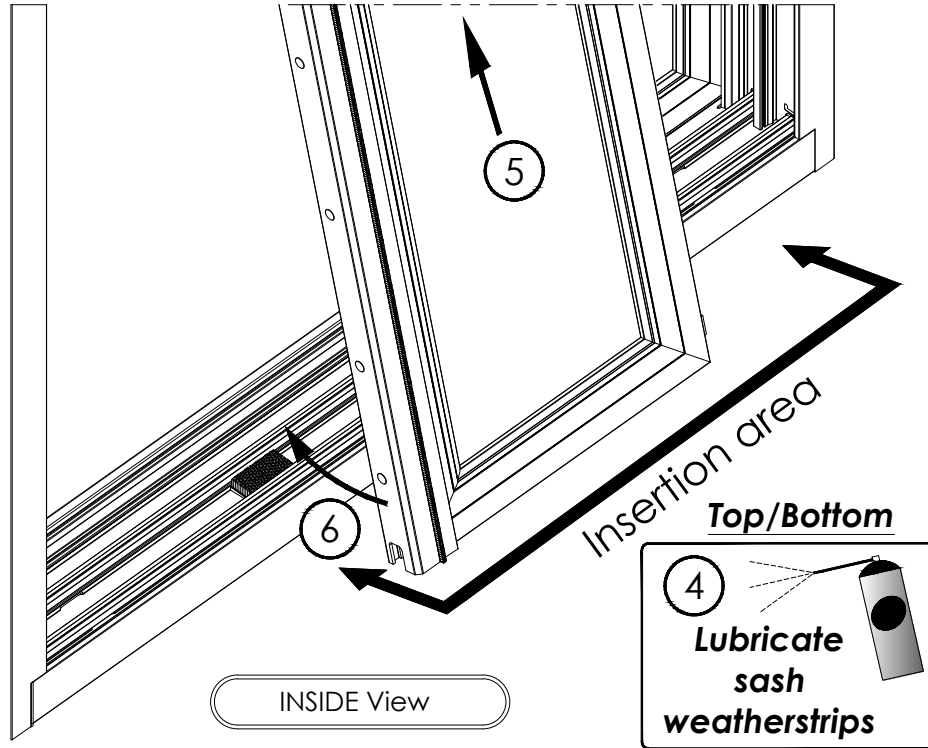

IMPORTANT: Sash header engagement is minimal at this stage. (The sash is free standing and could disengage from the header until head track is installed (see next page).

A

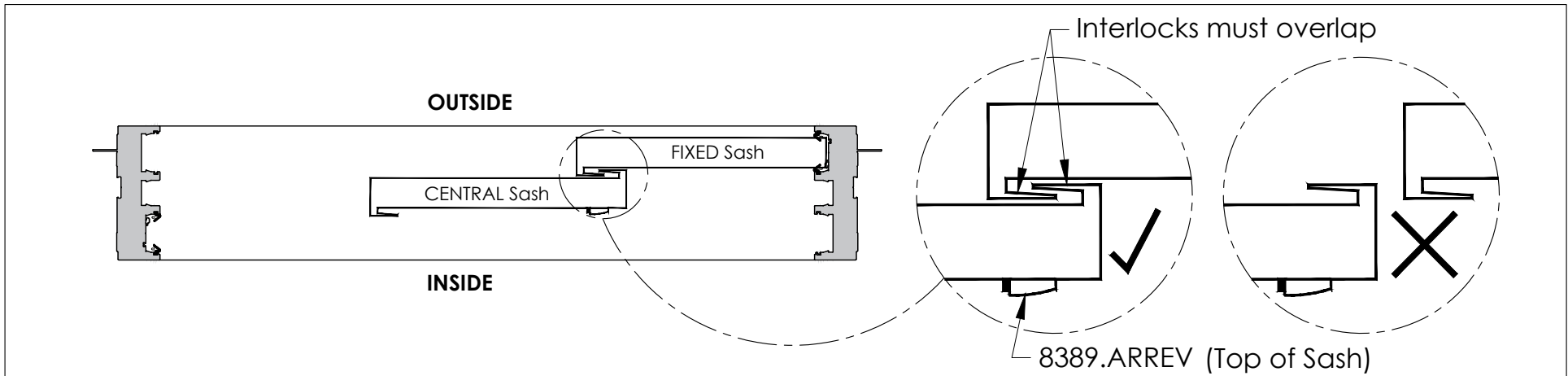



STEP:
8

(Continued) Installation of Central Sash & Head Tracks #8321

REVISION:
2021/03/10

PAGE:
P37

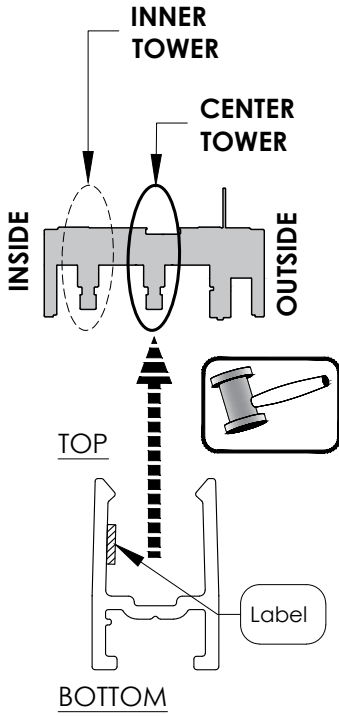
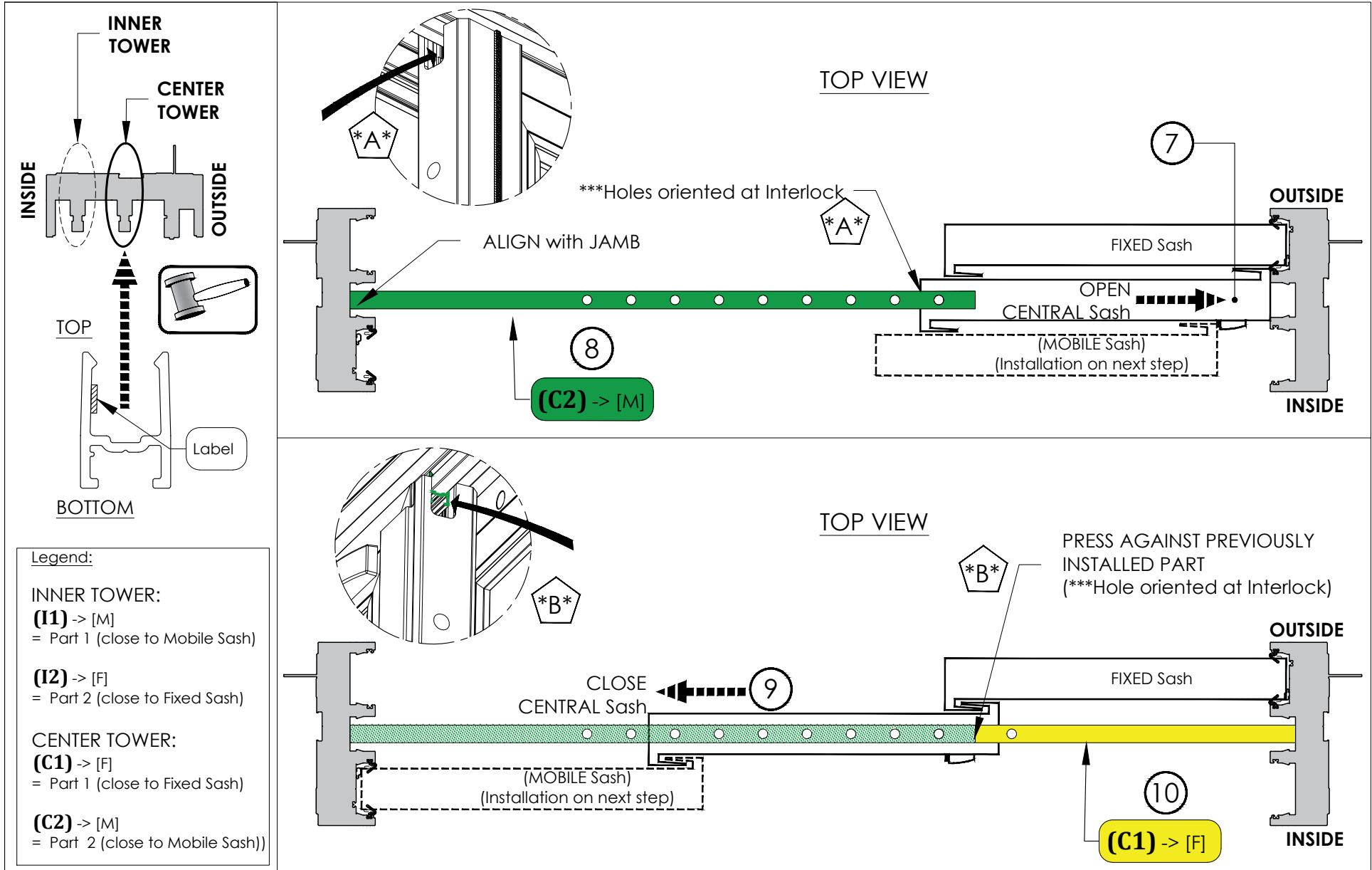

Legend:

INNER TOWER:
(I1) -> [M]
 = Part 1 (close to Mobile Sash)

(I2) -> [F]
 = Part 2 (close to Fixed Sash)

CENTER TOWER:
(C1) -> [F]
 = Part 1 (close to Fixed Sash)

(C2) -> [M]
 = Part 2 (close to Mobile Sash))





Installation of Mobile Sash & Head Tracks #8321

Tools and components required for this step

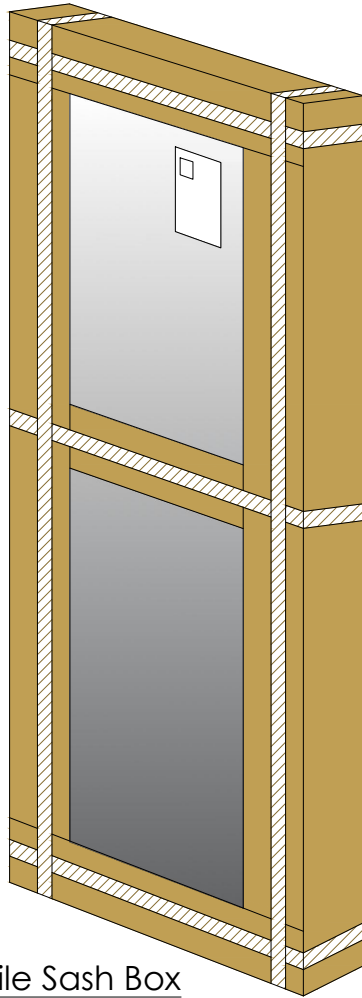

Mobile Sash Box (1X)

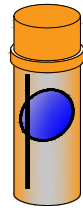

Invisible Lubricant Silicone (1X)

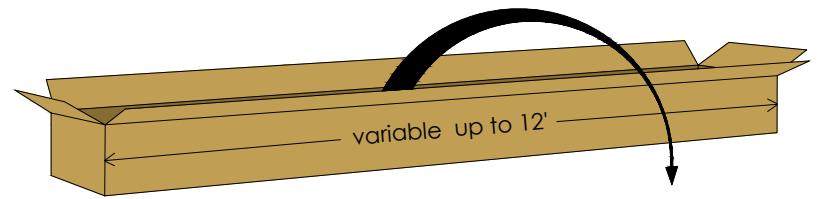

8321 (2X)

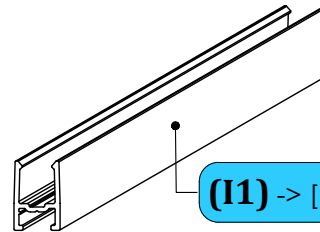

(I1) -> [F]

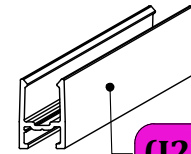

(I2) -> [M]

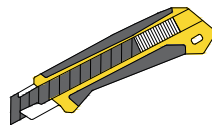

Knife (1X)

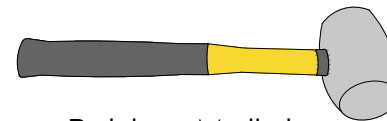

Rubber Mallet (1X)



STEP: **9**

(Continued) Installation of Mobile Sash & Head Tracks #8321

REVISION: 2021/03/10

PAGE: P39

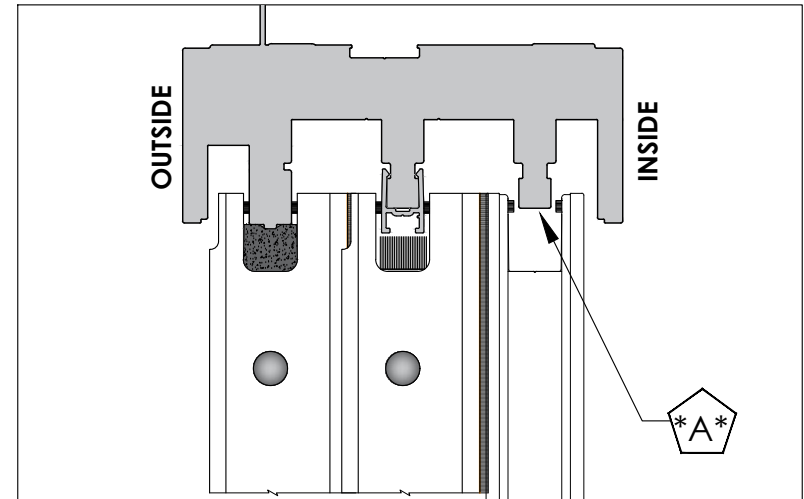
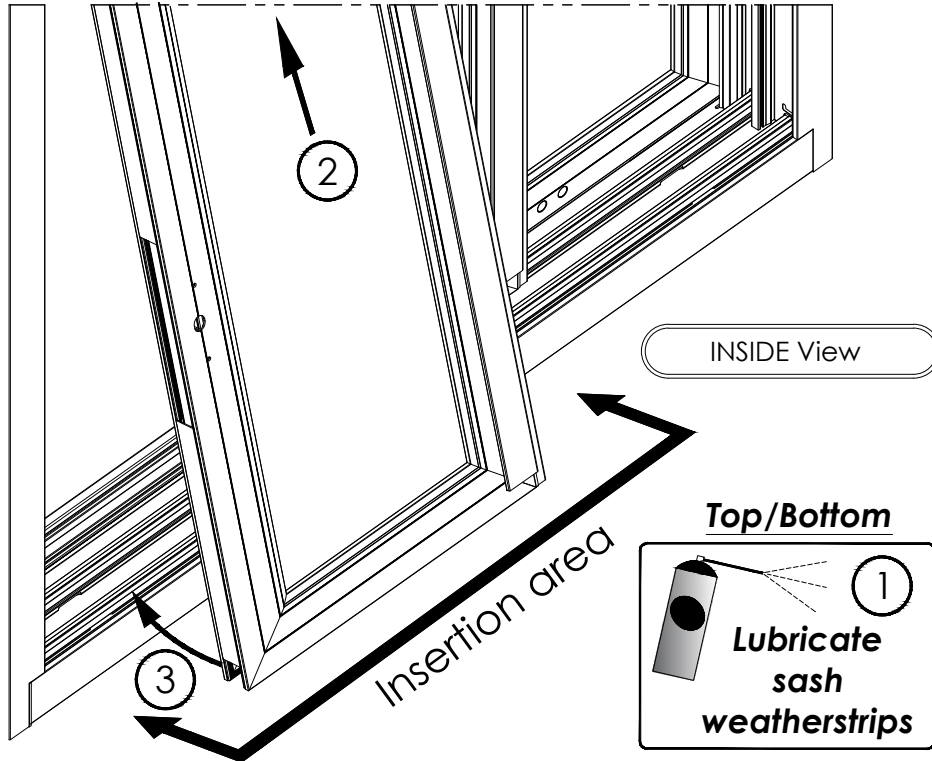

IMPORTANT: Sash header engagement is minimal at this stage. (The sash is free standing and could disengage from the header until head track is installed (see next page).

A

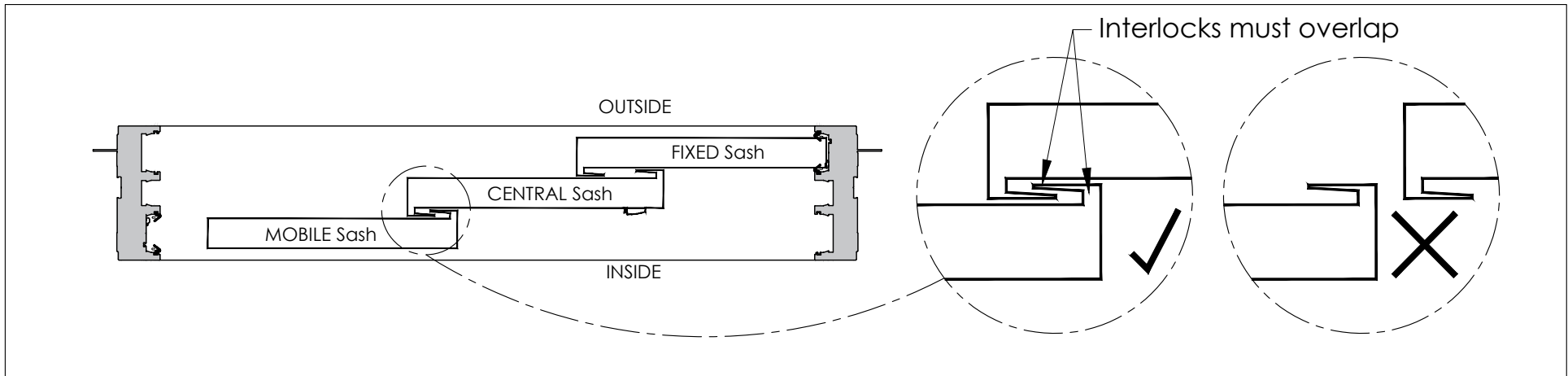



(Continued) Installation of Mobile Sash & Head Tracks #8321

REVISION:
2021/03/10

PAGE:
P40

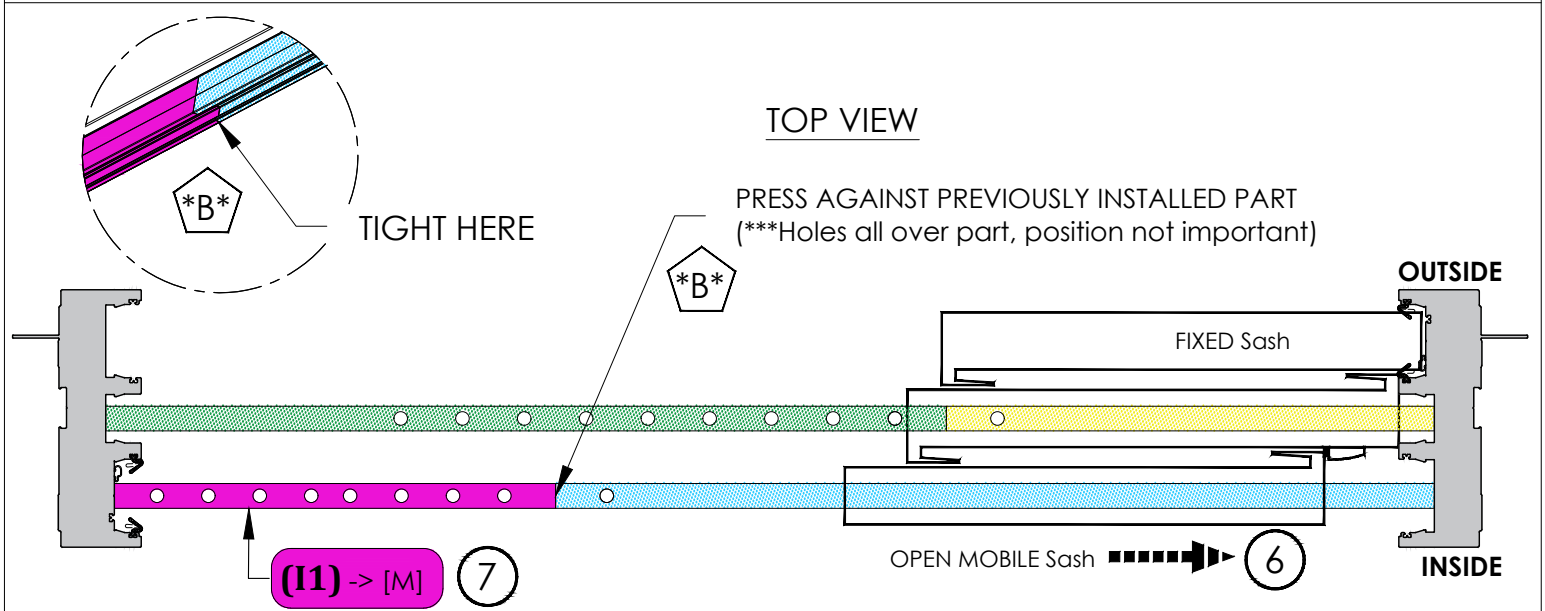
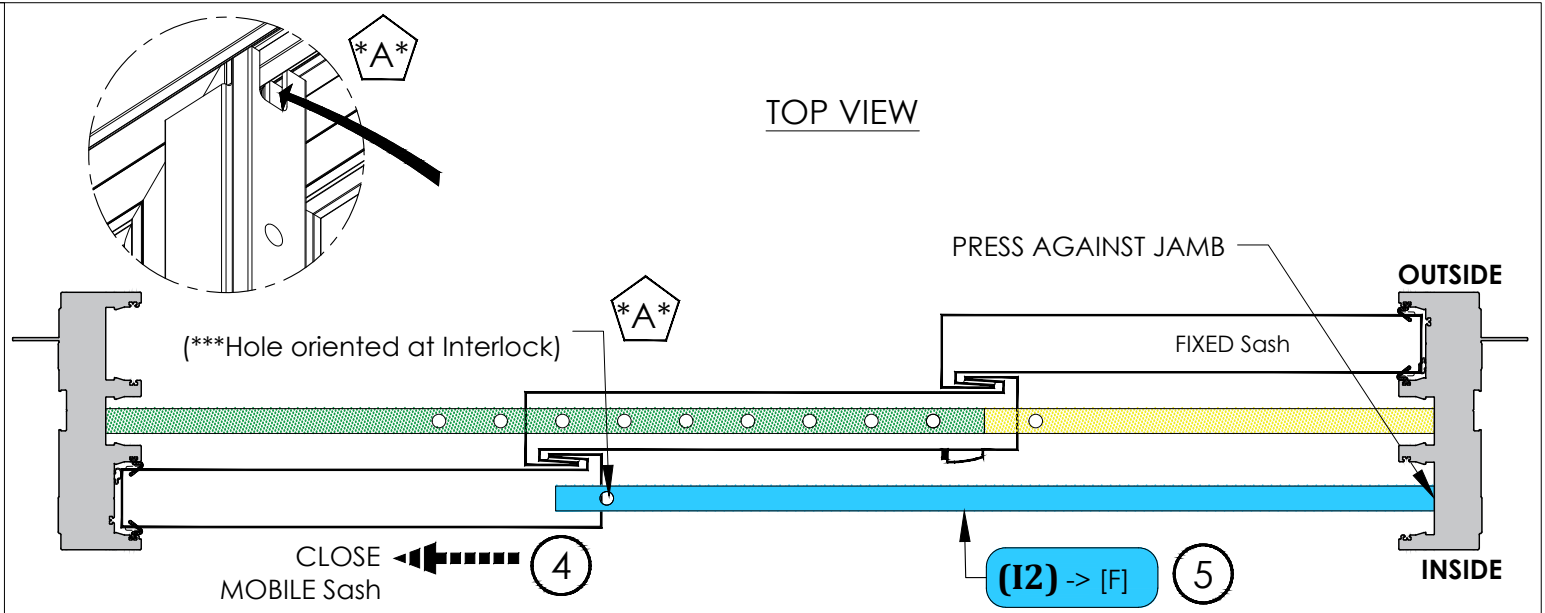
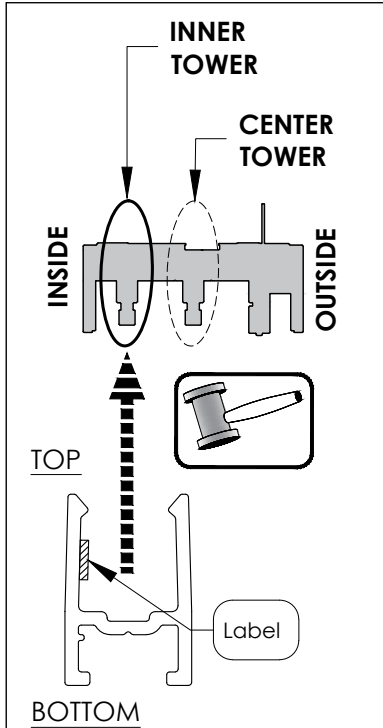

Legend:

INNER TOWER:
(1) -> [M]
 = Part 1 (close to Mobile Sash)

(12) -> [F]
 = Part 2 (close to Fixed Sash)

CENTER TOWER:
(C1) -> [F]
 = Part 1 (close to Fixed Sash)

(C2) -> [M]
 = Part 2 (close to Mobile Sash))



STEP:
10

Adjustment of the Sash

REVISION:
2021/03/10

PAGE:
P41

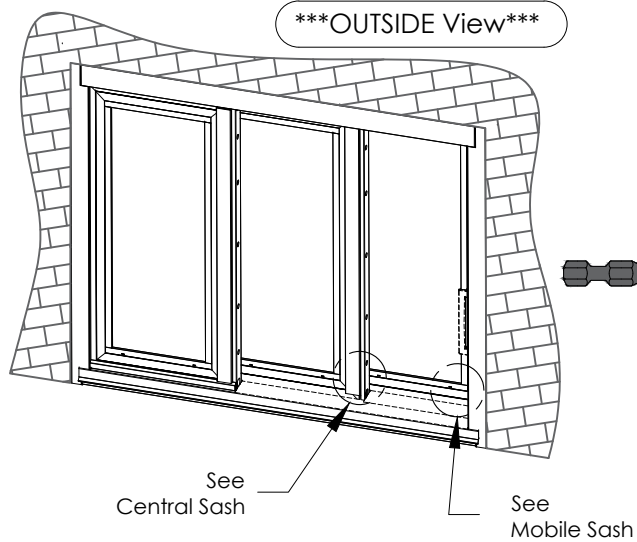

A **ATTENTION:**
Adjust the height and squareness of the sashes (centrals and mobiles) with the adjusting screw.



Screwdriver Bit
Quadrex 6" #2 (1X)

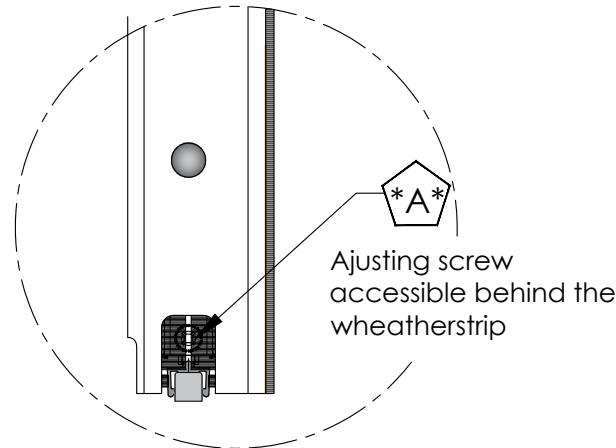

Central Sash

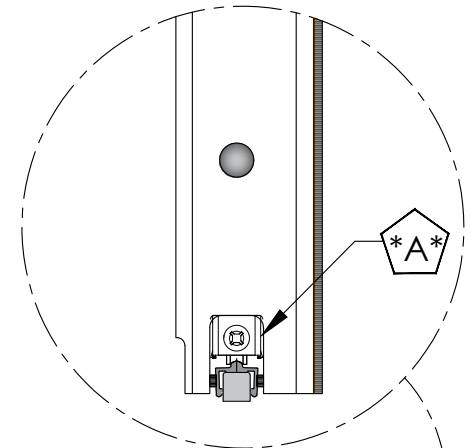

Mobile Sash

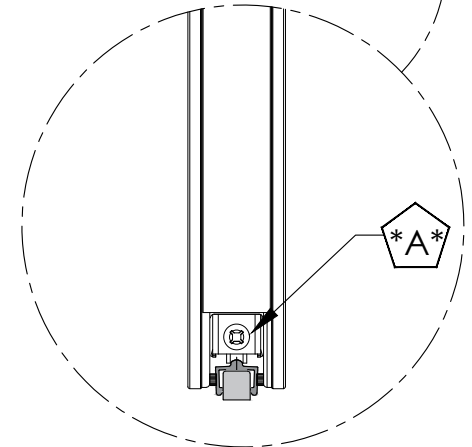

INSIDE View

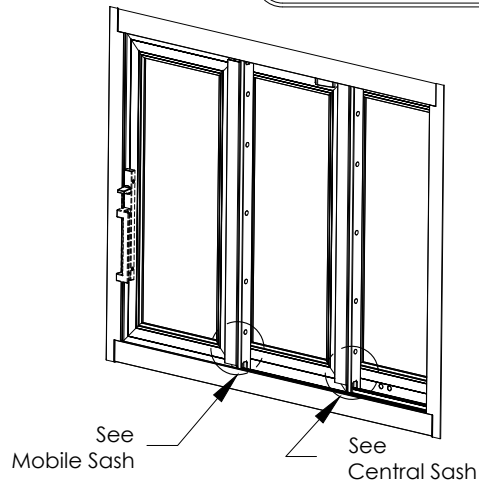



Installation of Head Blocks

REVISION: 2021/03/10

PAGE: P42

Tools and hardware required for this step



Impact
(1X)

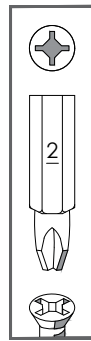

Screwdriver Bit
(1X)

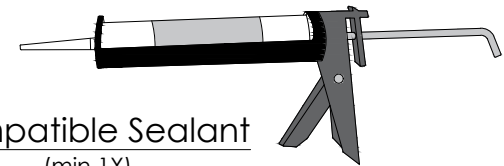

Compatible Sealant
(min.1X)



Screwdriver Bit
Quadrex 6" #2 (1X)

08375.00.SACn2.3V : HEAD Hardware bag

8941.VIS08
(8X)
BLACK

Assembled with foam 8373

00703.ADM35
(2X)

8703.BMSCF
(1X)



(Continued) Installation of Head Blocks

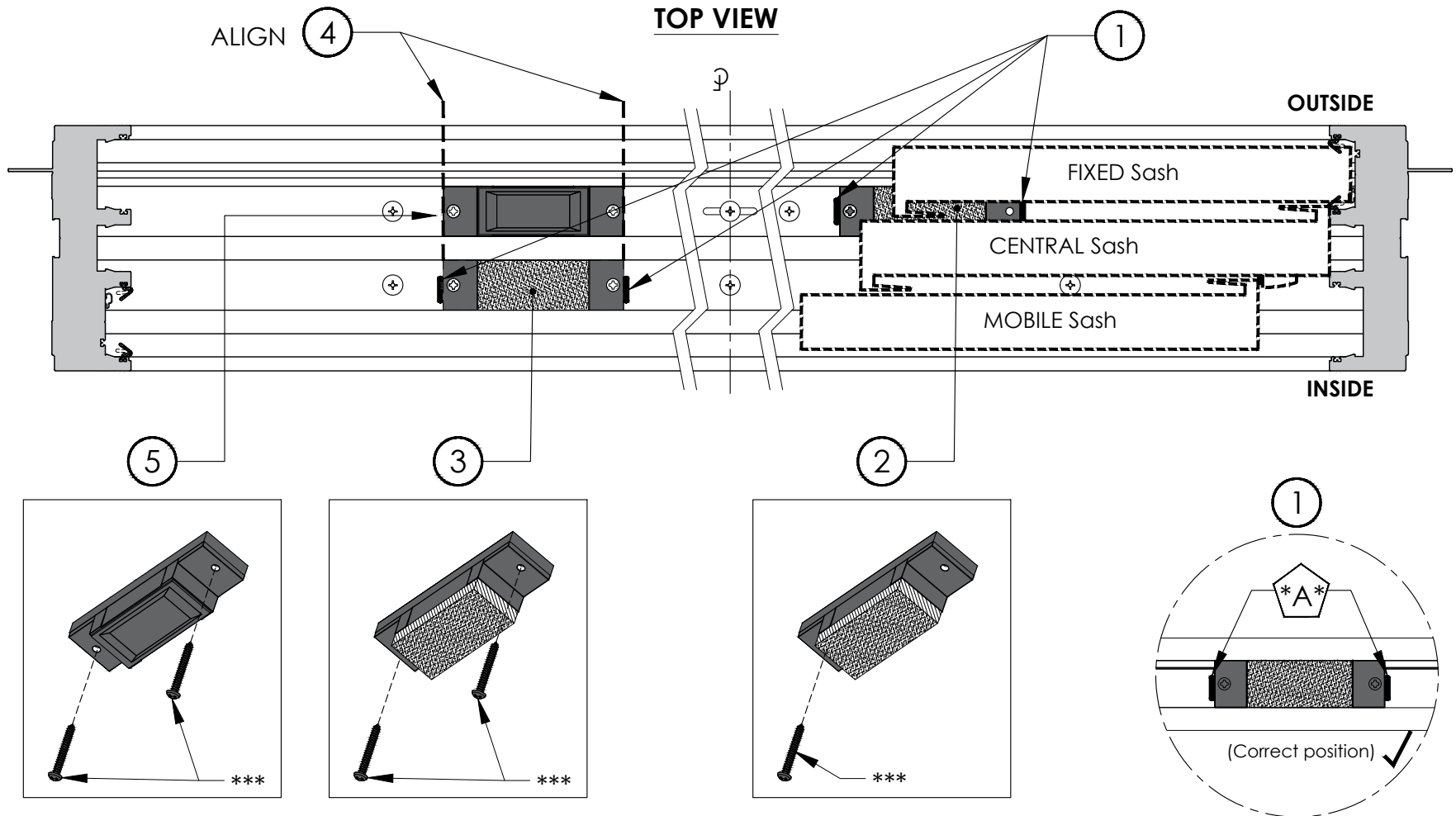

*****ATTENTION***:**

**Do not overtighten screws
(Foam under head block should not be compressed)**

ATTENTION:
**The blocks must be centered
between the marks.**



(Continued) Installation of Head Blocks

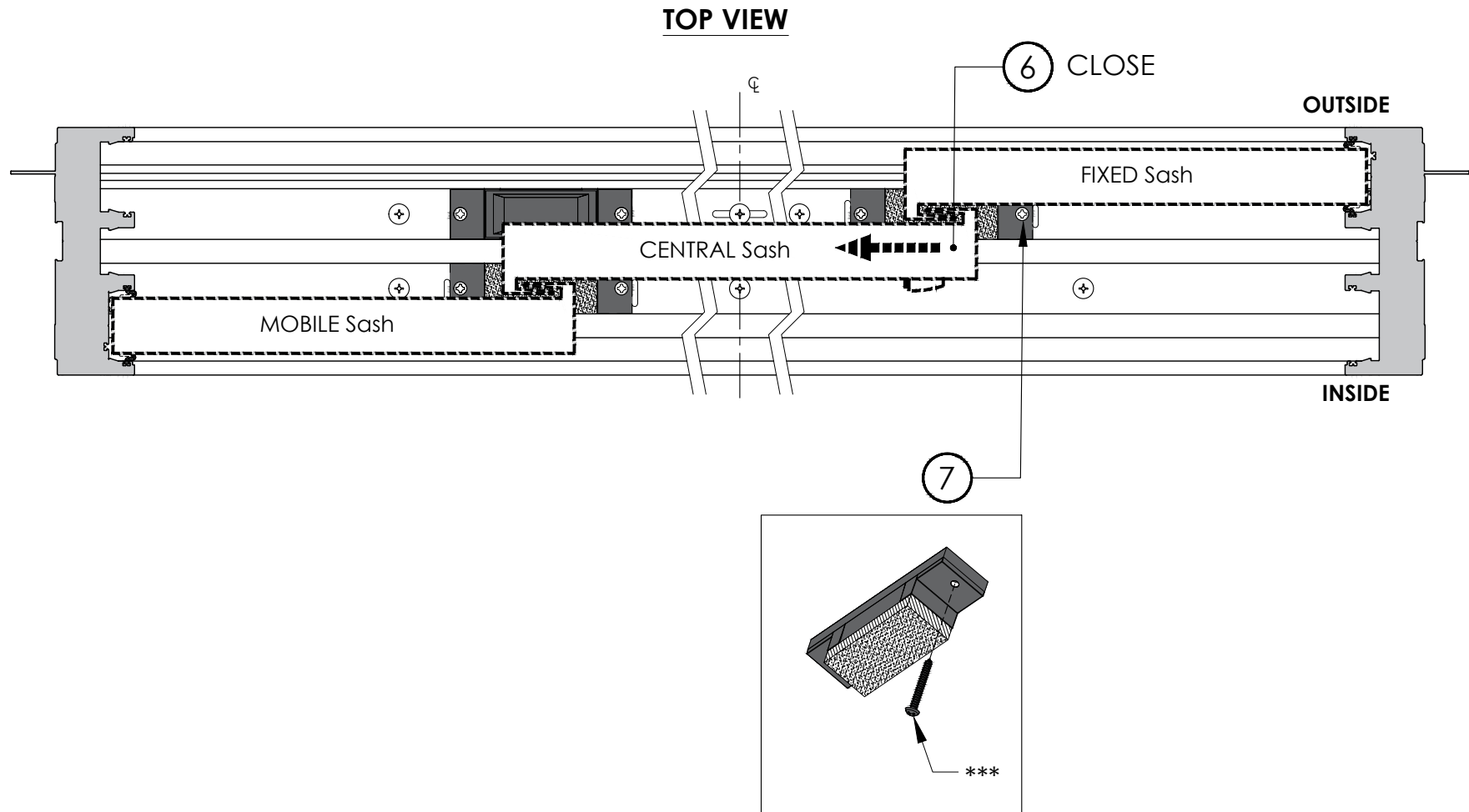

*****ATTENTION***:**

**Do not overtighten screw
(Foam under head block should not be compressed)**



(Continued) Installation of Head Blocks

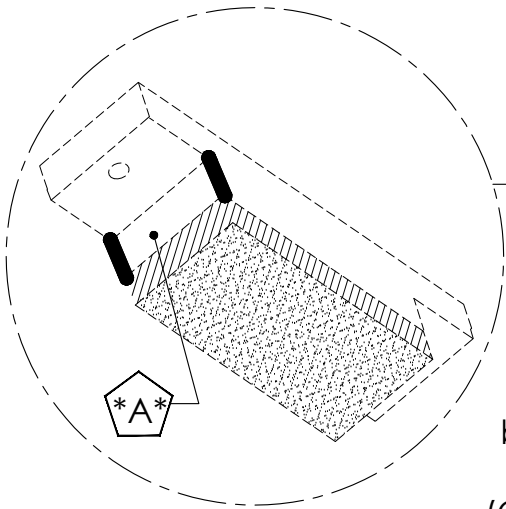

Apply a vertical bead of sealant on each edge. (Outer face only)

9

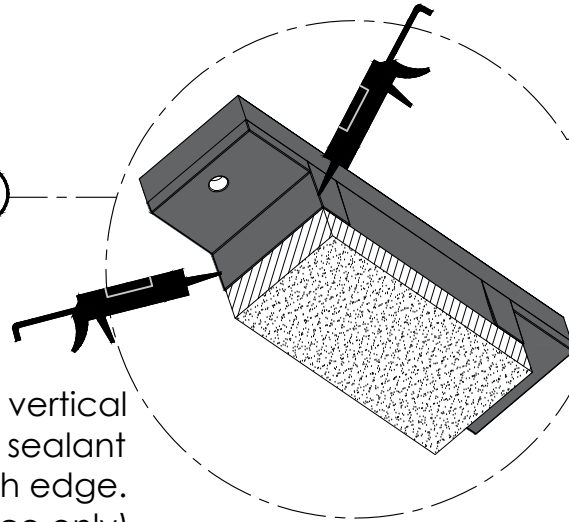

b

BLOCK W/O Pile (Sealant not required)

a

INSIDE View

OPEN SASH 8

FIXED SASH Side

a

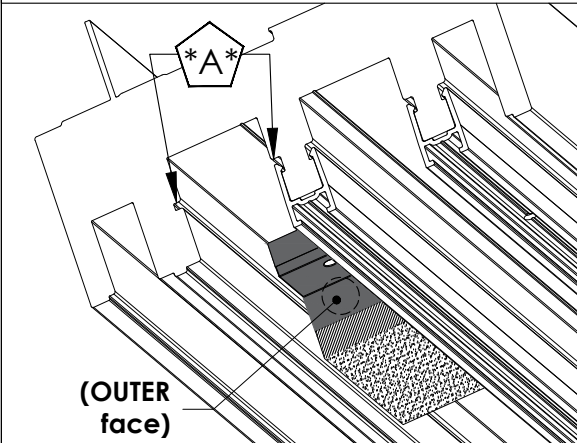

(OUTER face)



ATTENTION:

On the outer face of the head blocks WITH Weatherstrip: Make sure the grooves in the head are filled with sealant.

MOBILE SASH Side

b

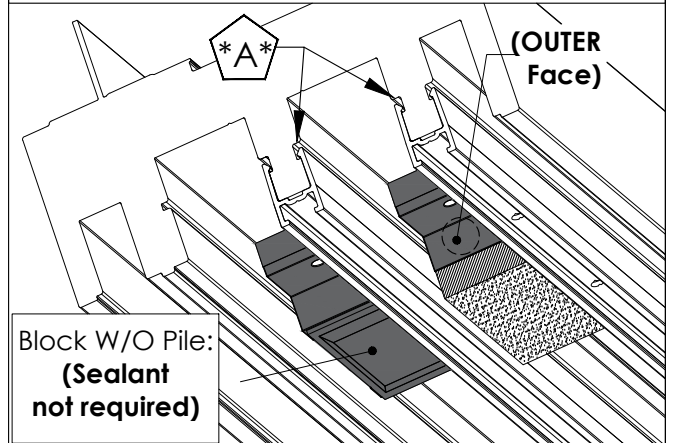

(OUTER Face)

Block W/O Pile: (Sealant not required)



Installation of Head Covers #8323

REVISION:
2021/03/10

PAGE:
P46

Components required for this step

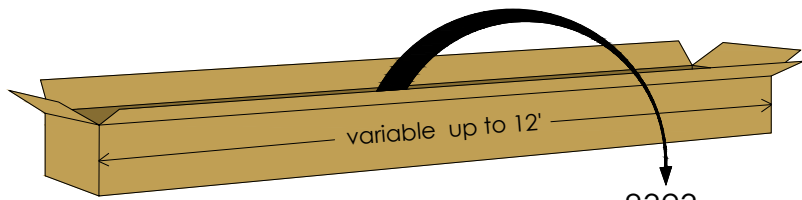

8323
(4X)

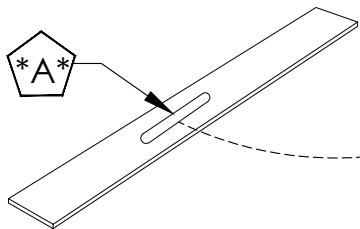

8323.(--)



PAY ATTENTION TO THE COLOR IF THE DOOR IS PAINTED

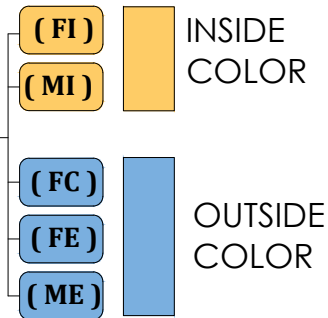

ATTENTION:
Label should not be visible when part is installed.
(See next page)

Legend:

On the Fixe Sash cavity:

- FI** = Fixe (Inside)
- FC** = Fixe (Central)
- FE** = Fixe (Outside)

On the Mobile Sash cavity:

- MI** = Mobile (Inside)
- ME** = Mobile (Outside)

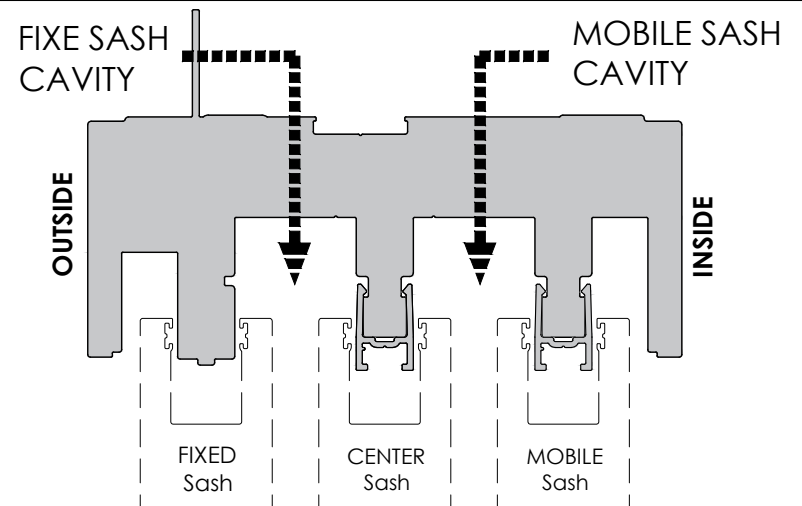



(Continued) Installation of Head Covers #8323

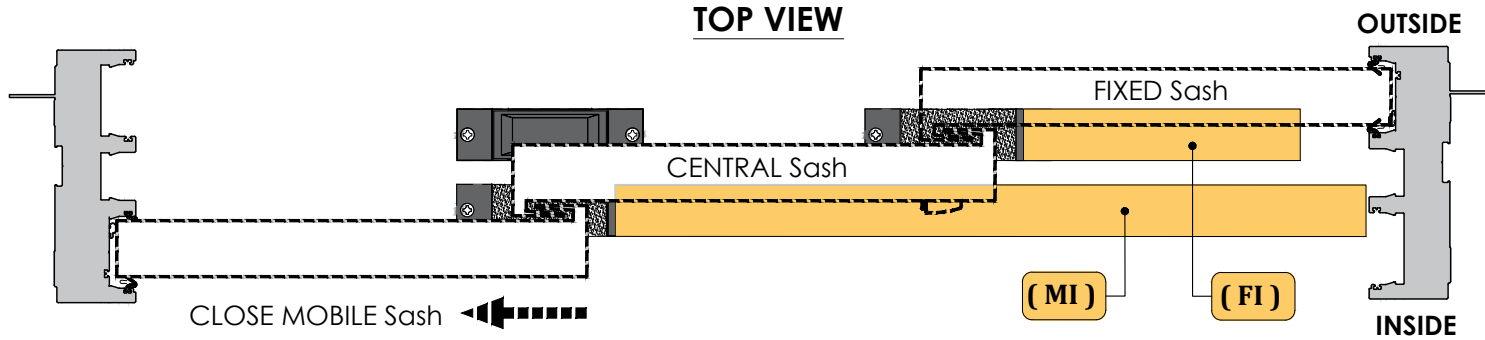

A

**Follow steps 1-2-3 for each head covers.
Make sure the parts are properly snapped.
(Pay attention at the color if door is painted)**

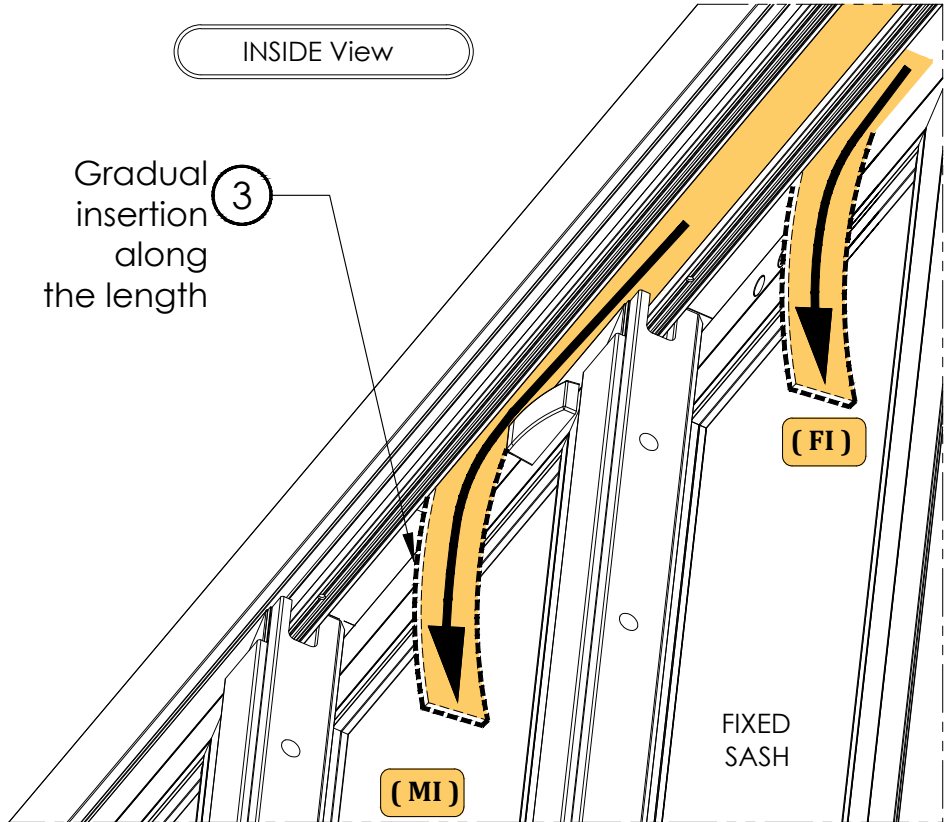
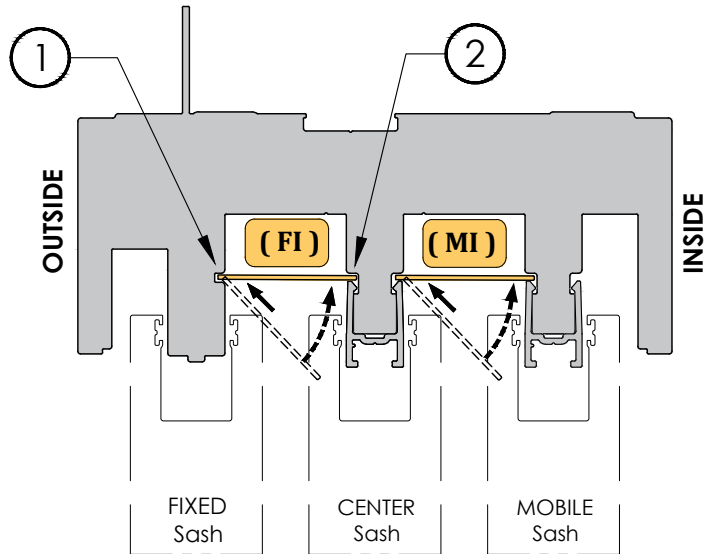



(Continued) Installation of Head Covers #8323

TOP VIEW

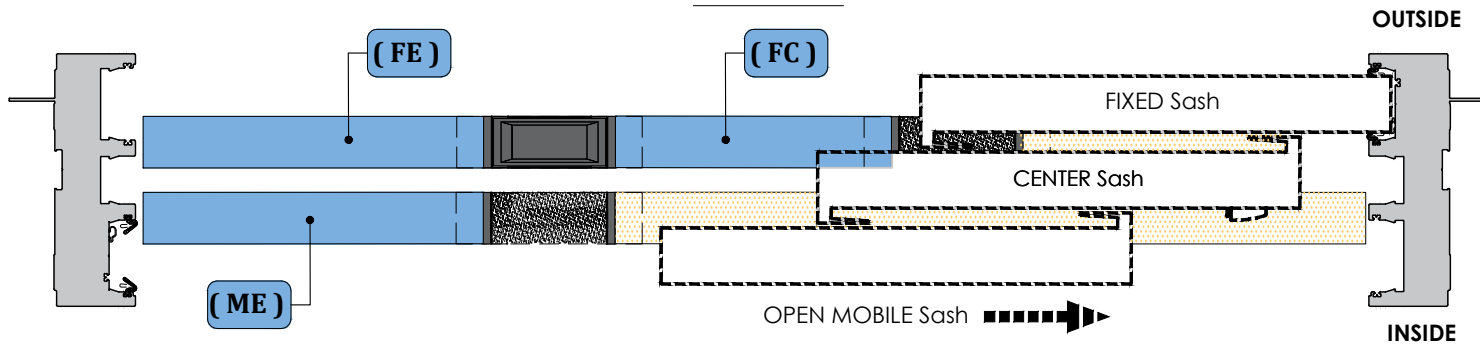

**Follow steps 4-5-6 for each head covers.
Make sure the parts are properly snapped.
(Pay attention at the color if door is painted)**

INSIDE View

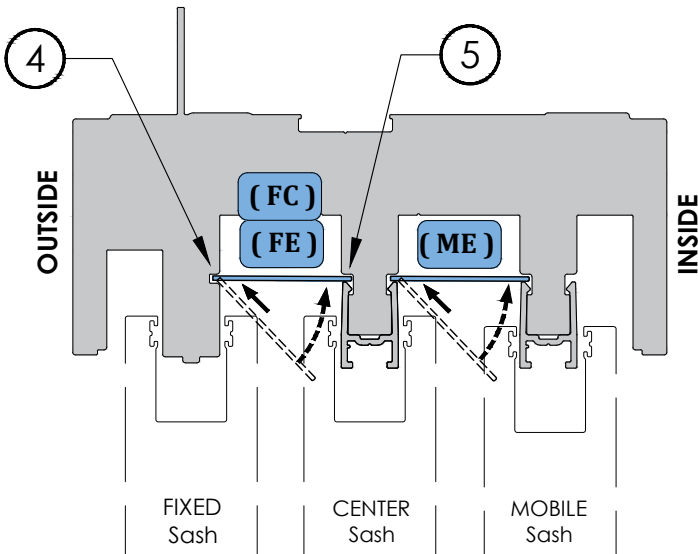
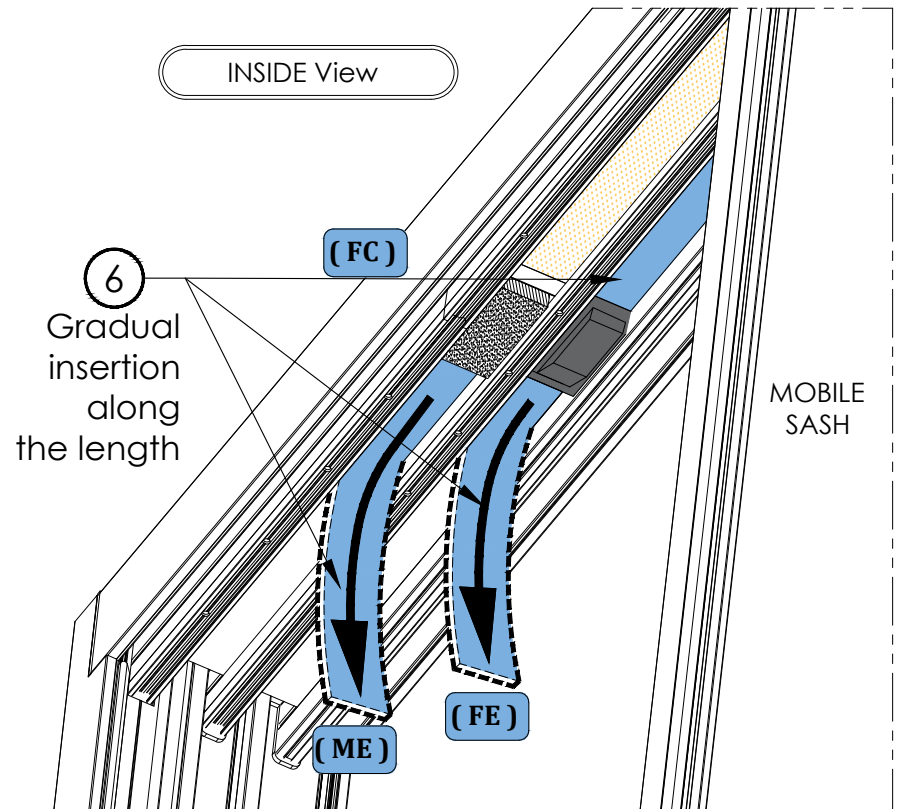



Fastening Head Tracks #8321 to the Frame

REVISION:
2021/03/10

PAGE:
P49

Tools and hardware required for this step



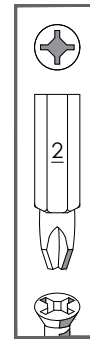

Impact
(1X)

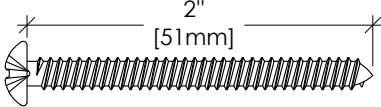

Screwdriver Bit
(1X)

 08380.00.SACn2.3V : HEAD Hardware bag

   8942.VIS10
(19X)



(Continued) Fastening Head Tracks #8321 to the Frame

REVISION: 2021/03/10

PAGE: P50

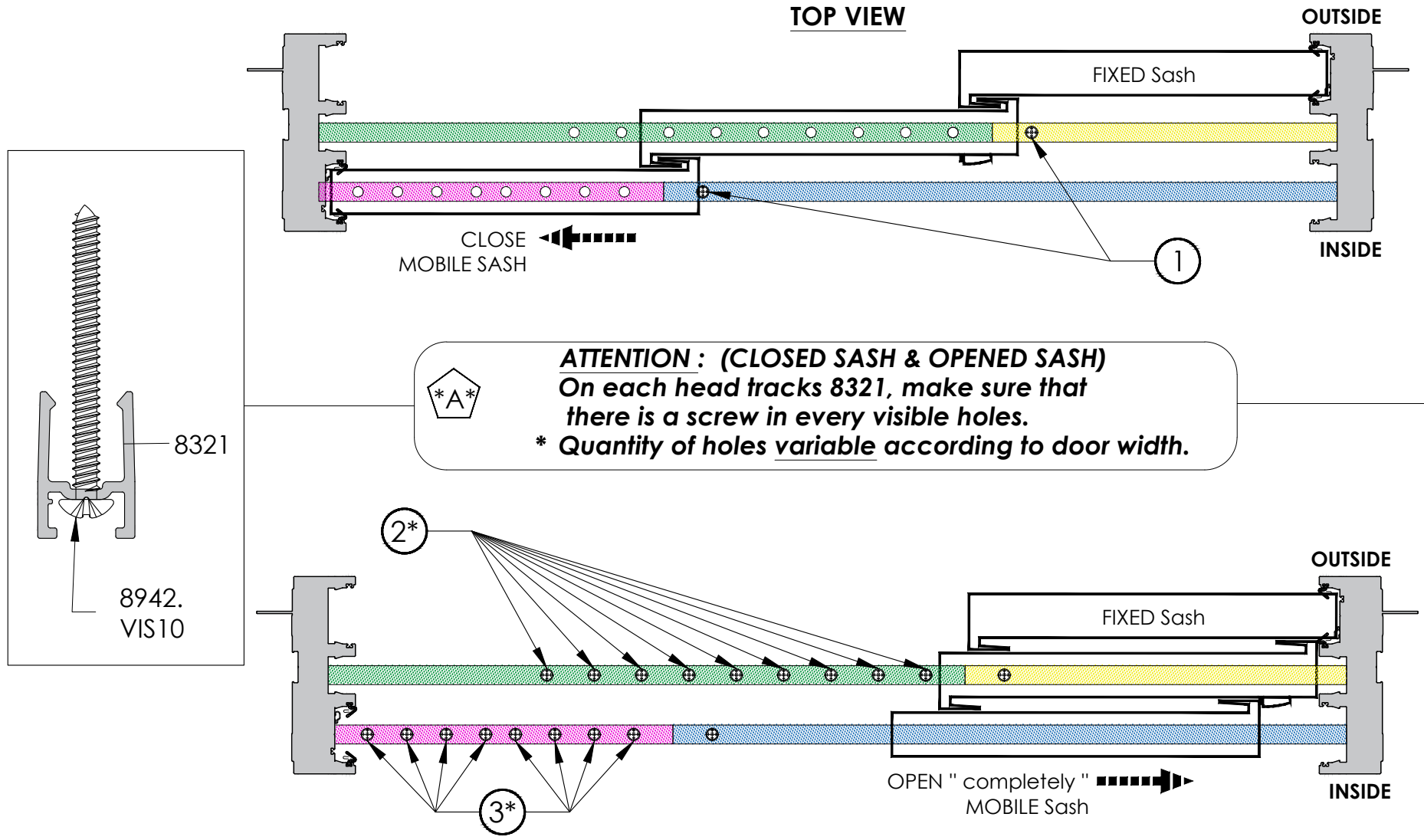



Installation of Groove Cover #8331

Tools and components required for this step

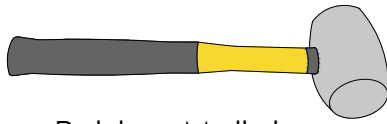

Rubber Mallet
(1X)

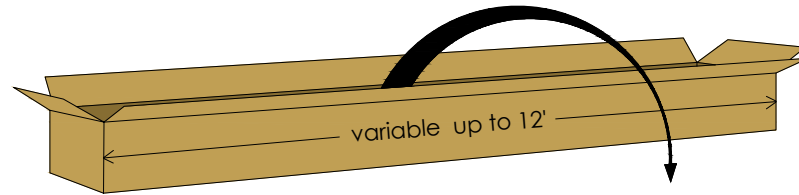

8331
(3X)

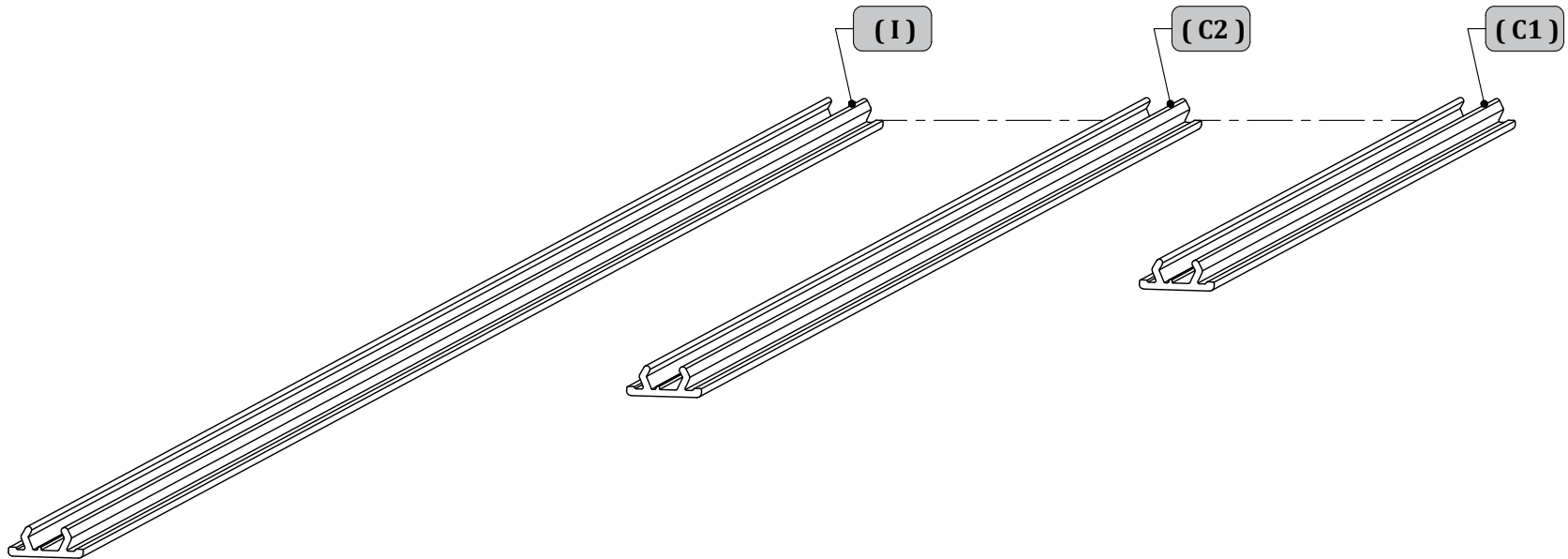



(Continued) Installation of Groove Cover #8331

REVISION:
2021/03/10

PAGE:
P52

INNER TOWER

CENTER TOWER

INSIDE **OUTSIDE**

Label

* (If painted door)

* **INSIDE COLOR**

	(C1)
	(I)

* **OUTSIDECOLOR**

	(C2)
--	------

Legend:

(I1) = Inner tower

(C1) = Central tower (Part 1)

(C2) = Central tower (Part 2)

TOP VIEW

OUTSIDE **INSIDE**

(C1)

FIXED Sash

(I)

FLUSH HERE

INSIDE View

*** Insert the excess length through the sash until reach the jamb.

A

Be careful not to scratch the part during insertion, especially if it is painted.

INSERT INTO SASH INTERLOCK ①

ON FULL LENGTH (VISIBLE PART)

③

PRESS AGAINST JAMB ②



(Continued) Installation of Groove Cover #8331

REVISION: 2021/03/10

PAGE: P53

INNER TOWER
CENTER TOWER

INSIDE **OUTSIDE**

Label

* (If painted door)

	(C1)
	(I1)

	(C2)

*OUTSIDECOLOR

Legend:
(I1) = Inner tower
(C1) = Central tower (Part 1)
(C2) = Central tower (Part 2)

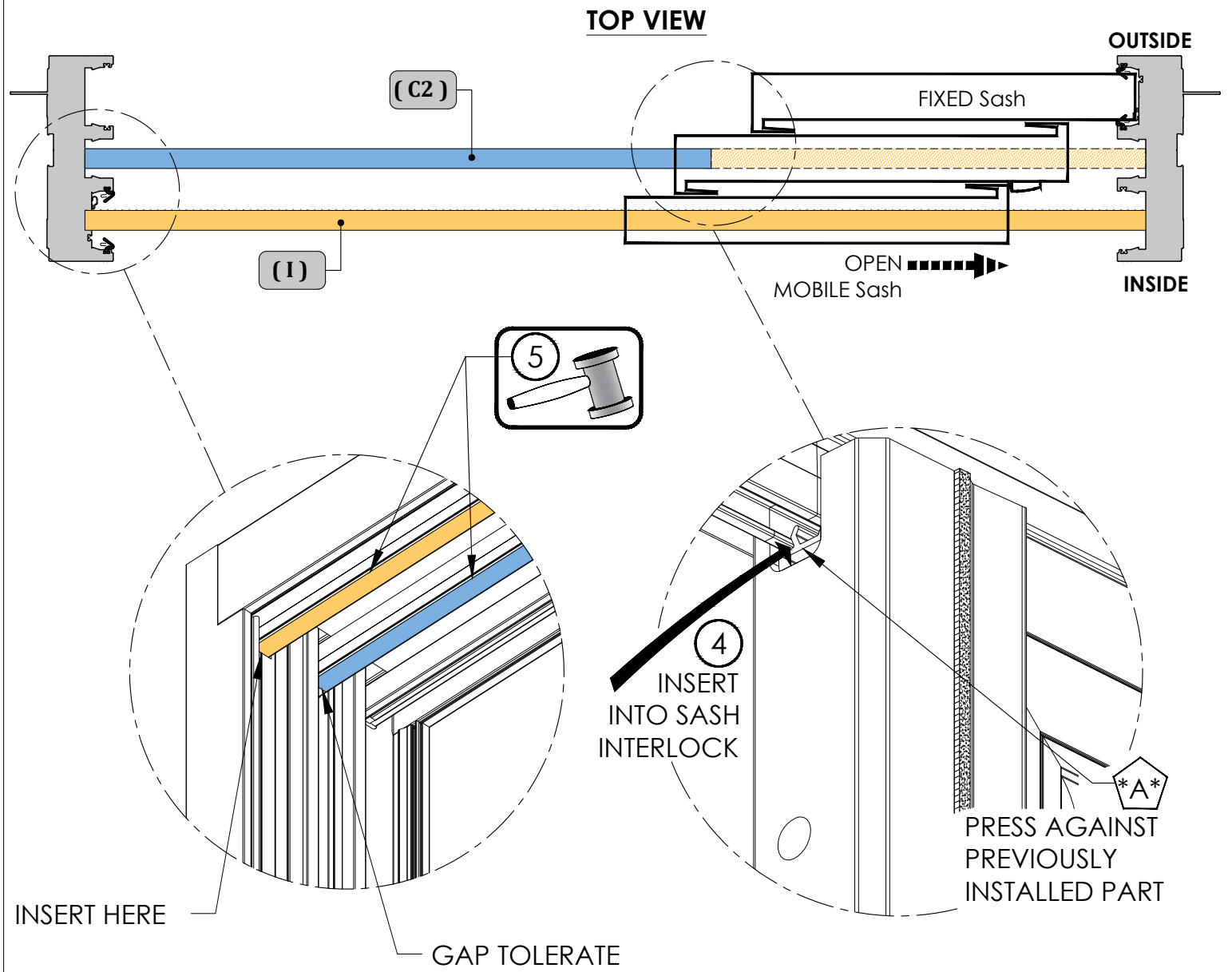



Installation of Jamb Cover (Interior) & Sash Stop

Tools and materials required for this step

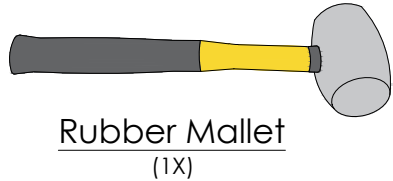

Impact (1X)

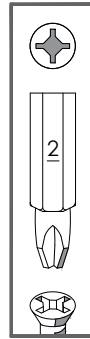

Screwdriver Bit (1X)

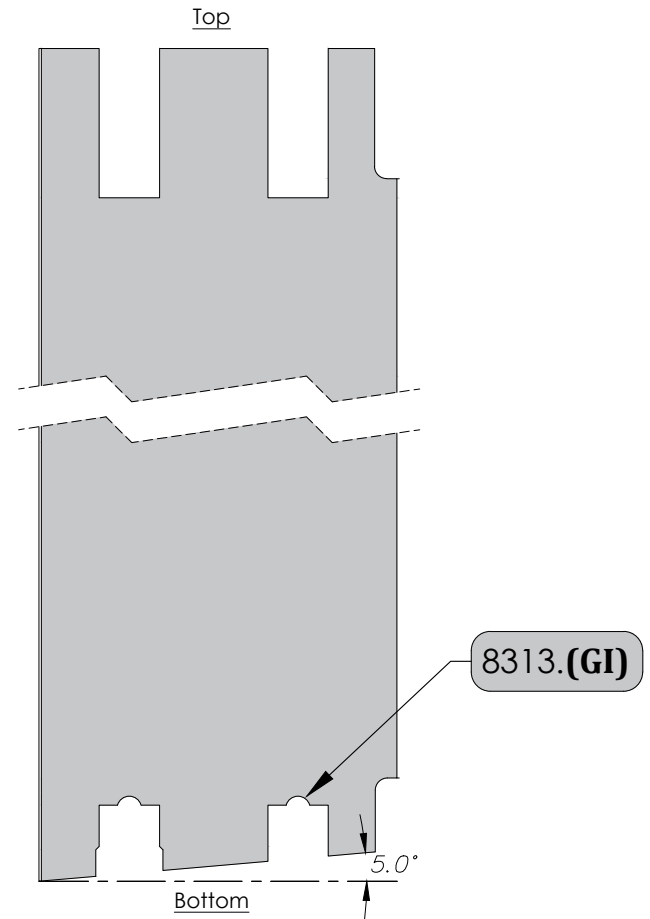
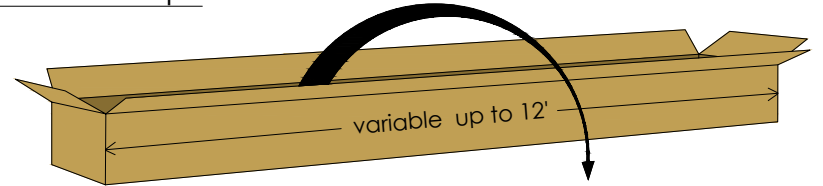

08380.00.SACn2.3V : HEAD Hardware bag

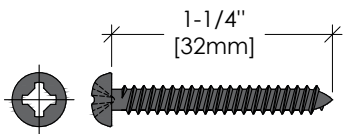

8941.VIS08 (2X) *black*

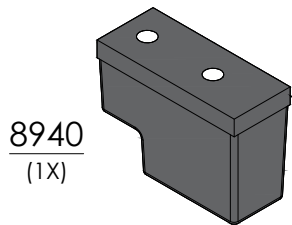

8940 (1X)

Assembled with shim 8789





STEP: 15

(Continued) Installation of Jamb Cover (Interior) & Sash Stop

REVISION: 2021/03/10

PAGE: P55

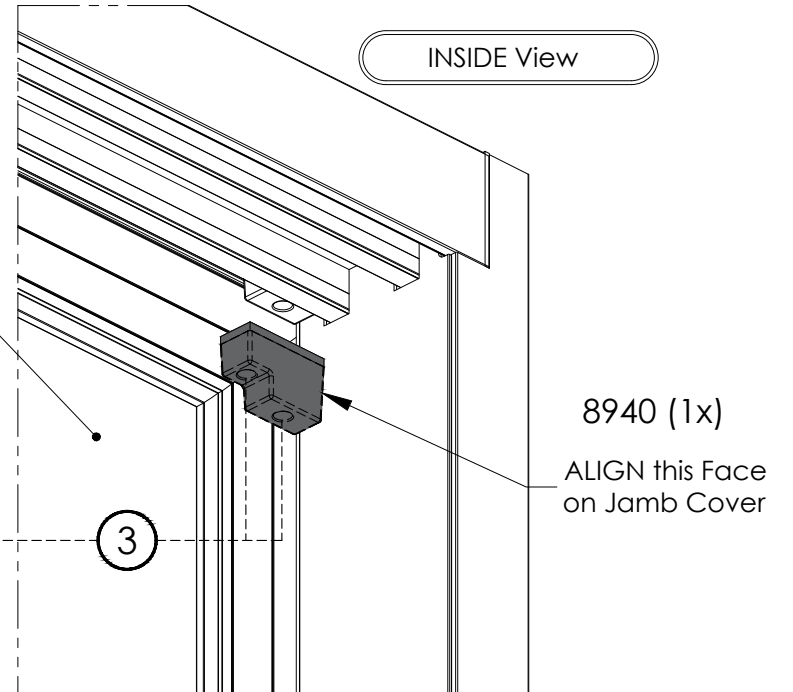
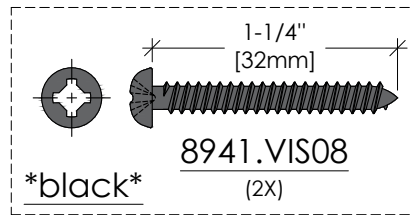
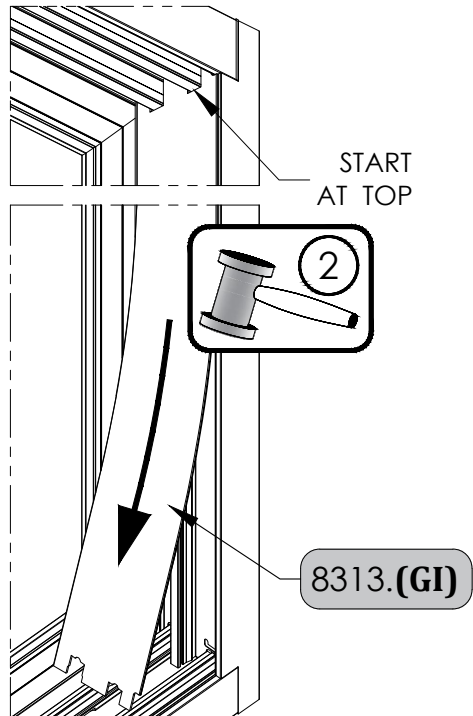
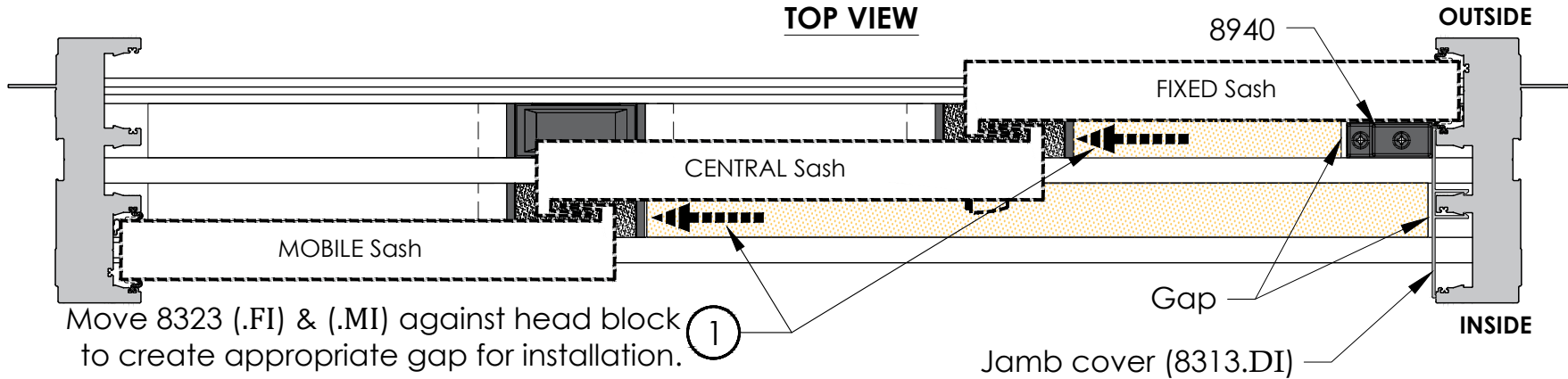



Installation of Handle, Lock & Keeper

REVISION:
2021/03/10

PAGE:
P56

Tools and hardware required for this step

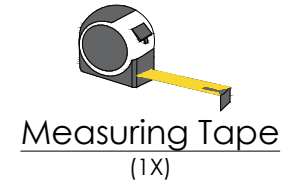
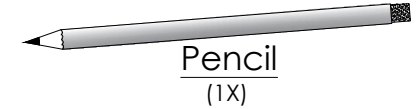
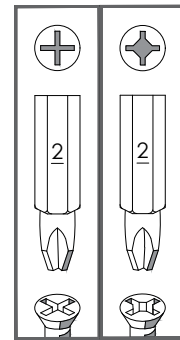
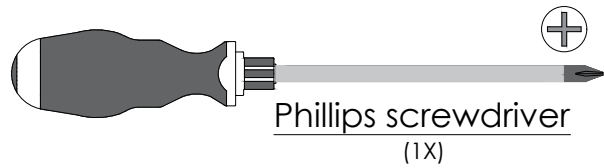
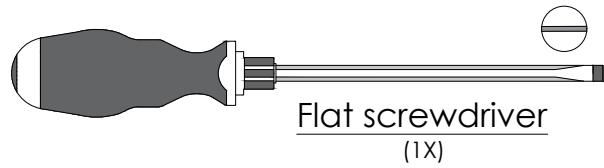

09250.SS.KT.ENS2P : SS Lock & Keeper bag

9250.SS.SER2P
(1X)

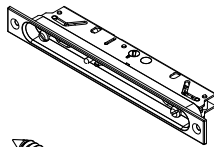

SS Screw
#10 x 2-1/2"
(2X)

~~* Not required *~~
~~9149.SS.VISME~~
~~(#10 x 3/4")~~
~~(2X)~~

9250.SS.GACHE
(1X)

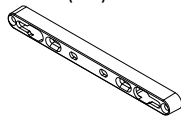

9250.SS.VISGA
(#10 x 1-3/4")
(4X)



08375.58.SACn3.3V :

FINISHED Hardware bag

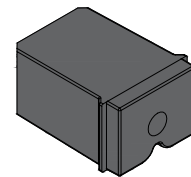

9150.CAPUC
(2X)

Handle
(model may differ
of illustration)

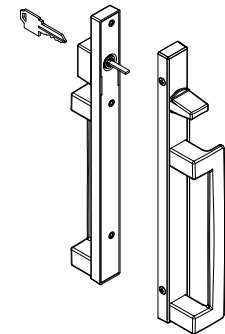



STEP: 16

(Continued) Installation of Handle, Lock & Keeper

REVISION: 2021/03/10

PAGE: P57

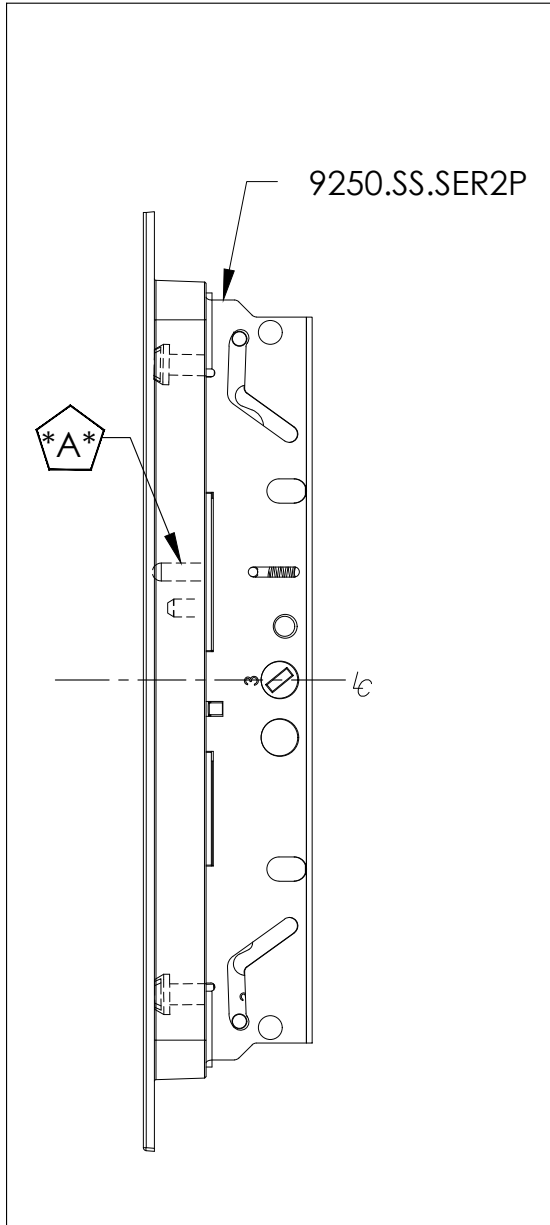

INSIDE View

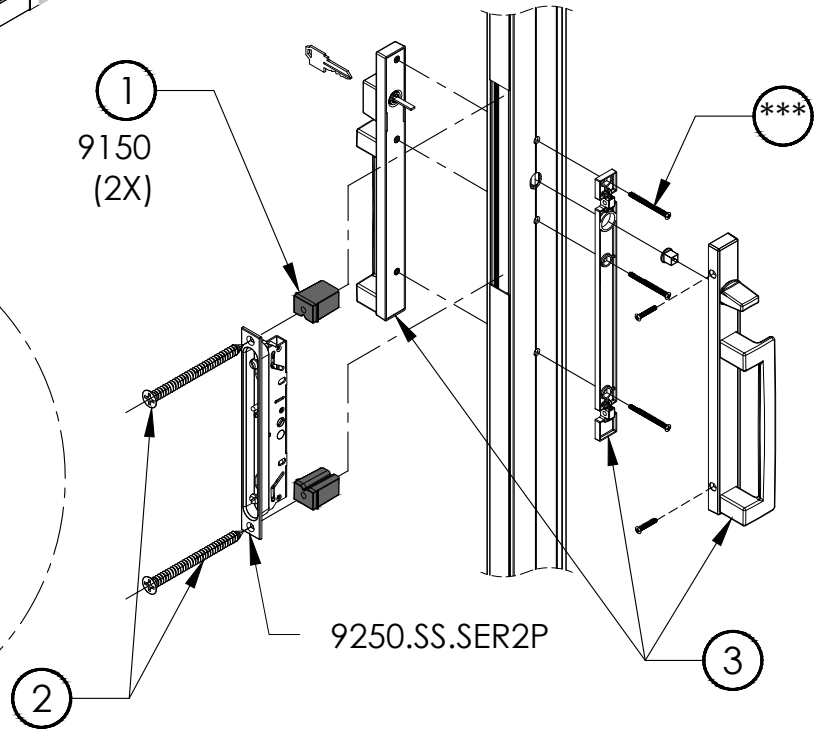
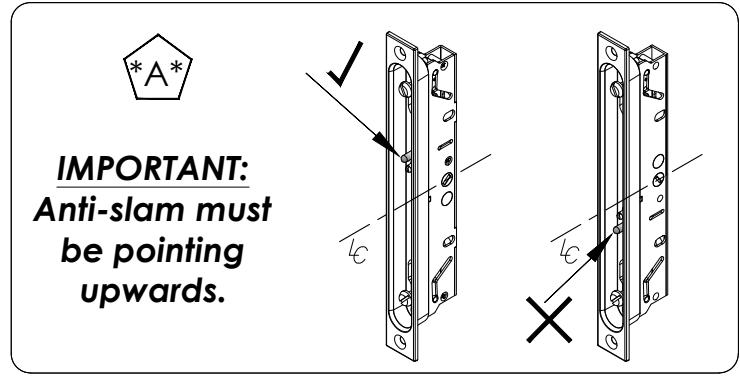
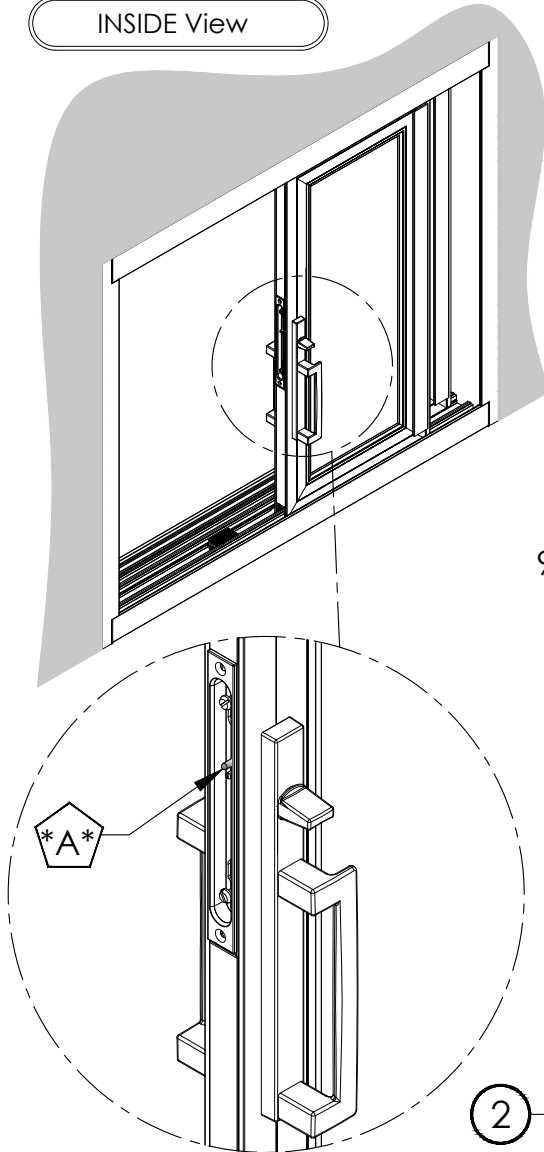



(Continued) Installation of Handle, Lock & Keeper

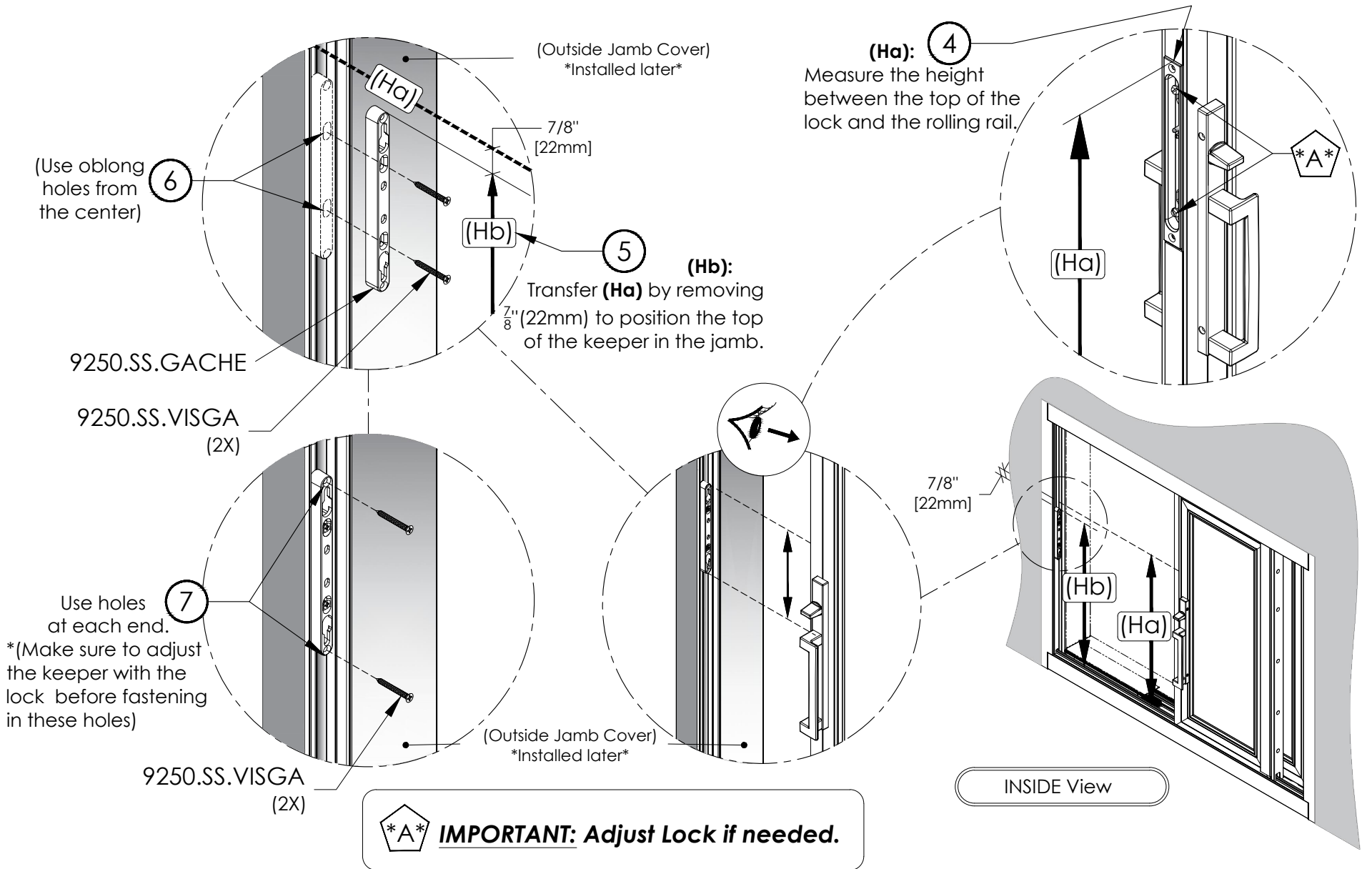



Installation of Drip Cap

Tools and components required for this step

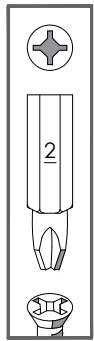

Screwdriver Bit
(1X)



Impact
(1X)

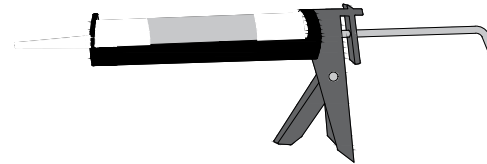

Compatible Sealant
(min.1X)

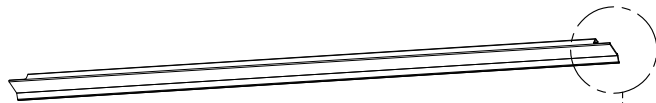
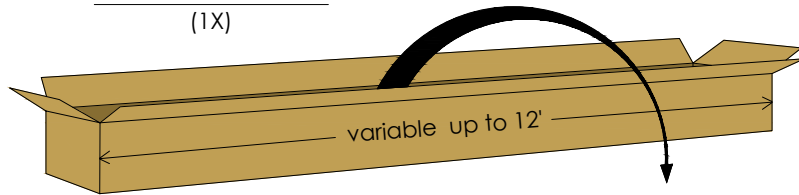

If painted door (OUT=Outside), rather use parts on red bag in Sill box.

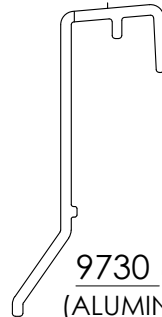

6352.IM (1X)
(PVC)



9730 (1X)
(ALUMINUM)

 08375.58.SACn3.3V : FINISHED Hardware bag

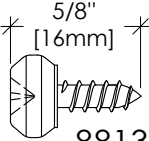

5/8"
[16mm]

8813.VIS10
(4X)

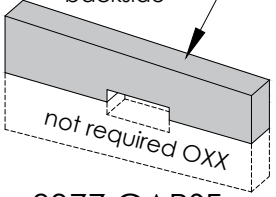

Adhesive
backside

not required OXX

8395.58.CAPVS.G
(1X) not required
OXX

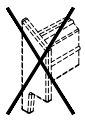

8377.GAPSF
(1X)

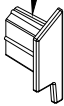
 8395.58.CAPVS.D
(1X)



(Continued) Installation of Drip Cap

REVISION: 2021/03/10

PAGE: P60

A
IMPORTANT:
Install a screw in each hole
after installing the 9730.

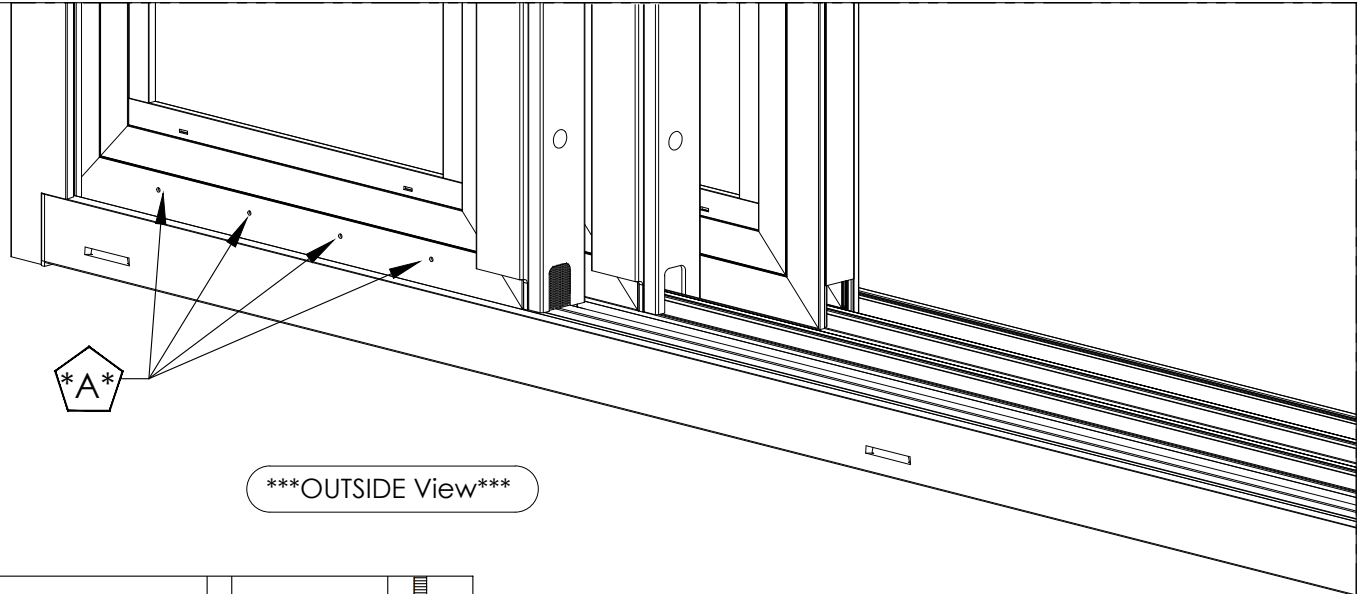

OUTSIDE View

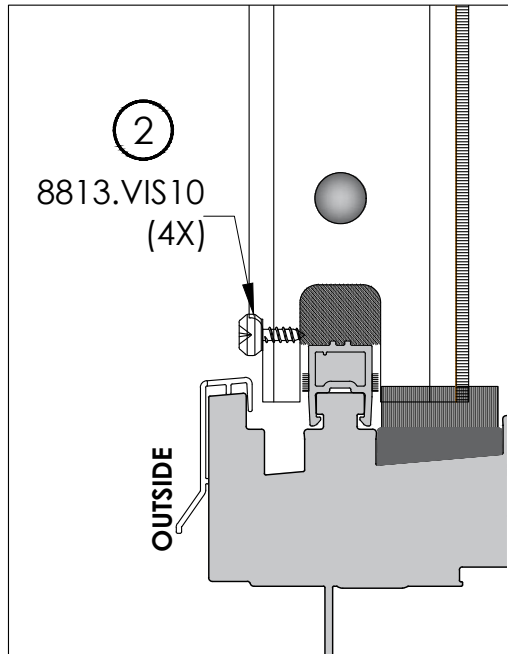
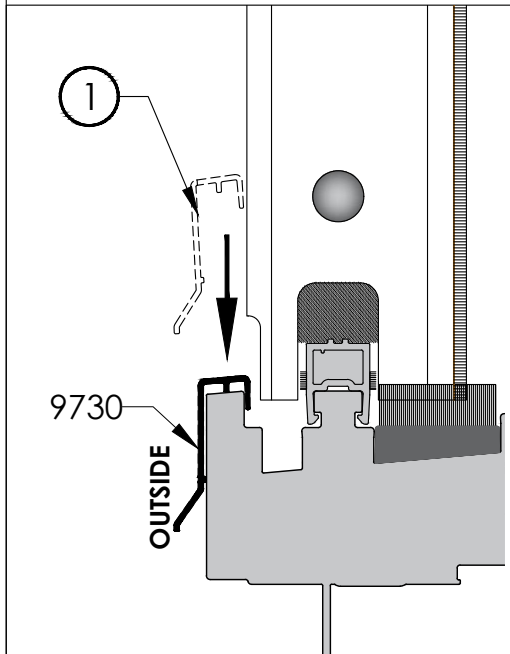



(Continued) Installation of Drip Cap

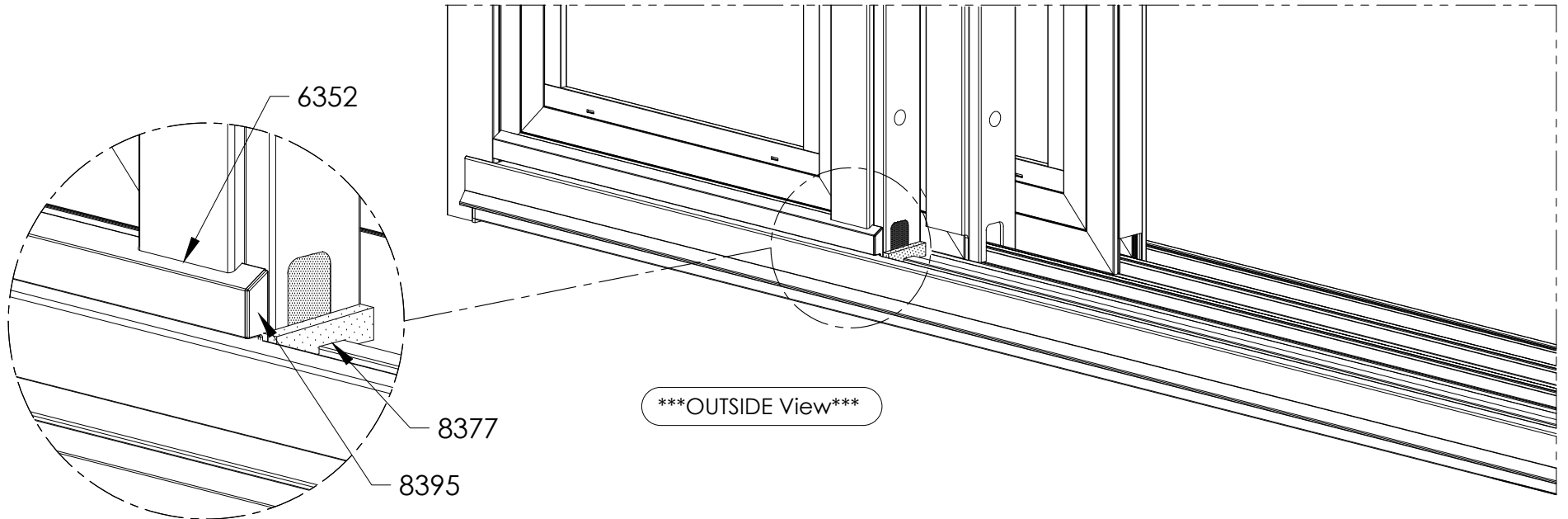
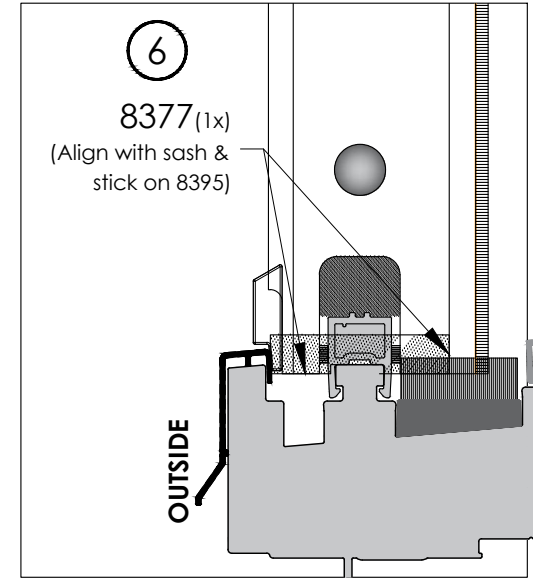
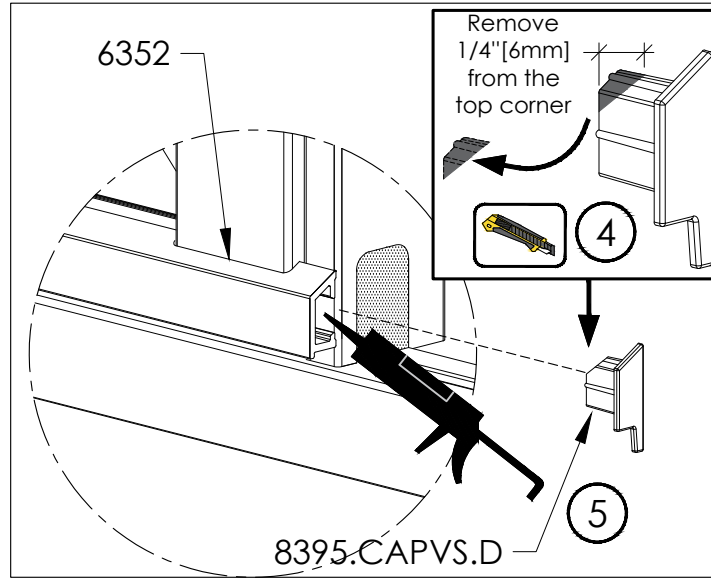
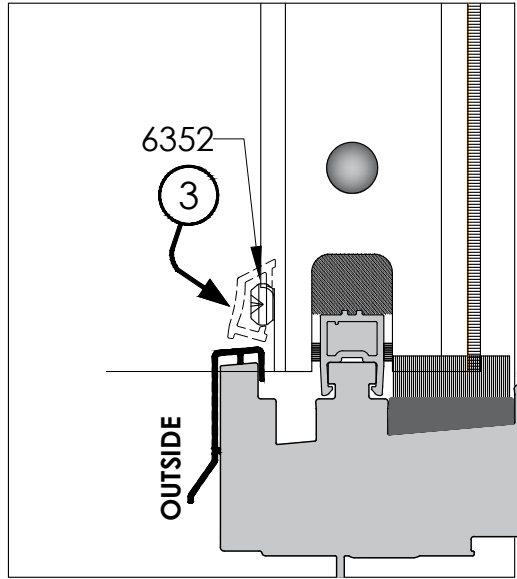



Installation of Sills Covers

*Tools and components required for this step **

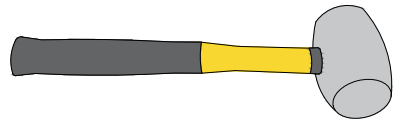

Rubber Mallet
(1X)

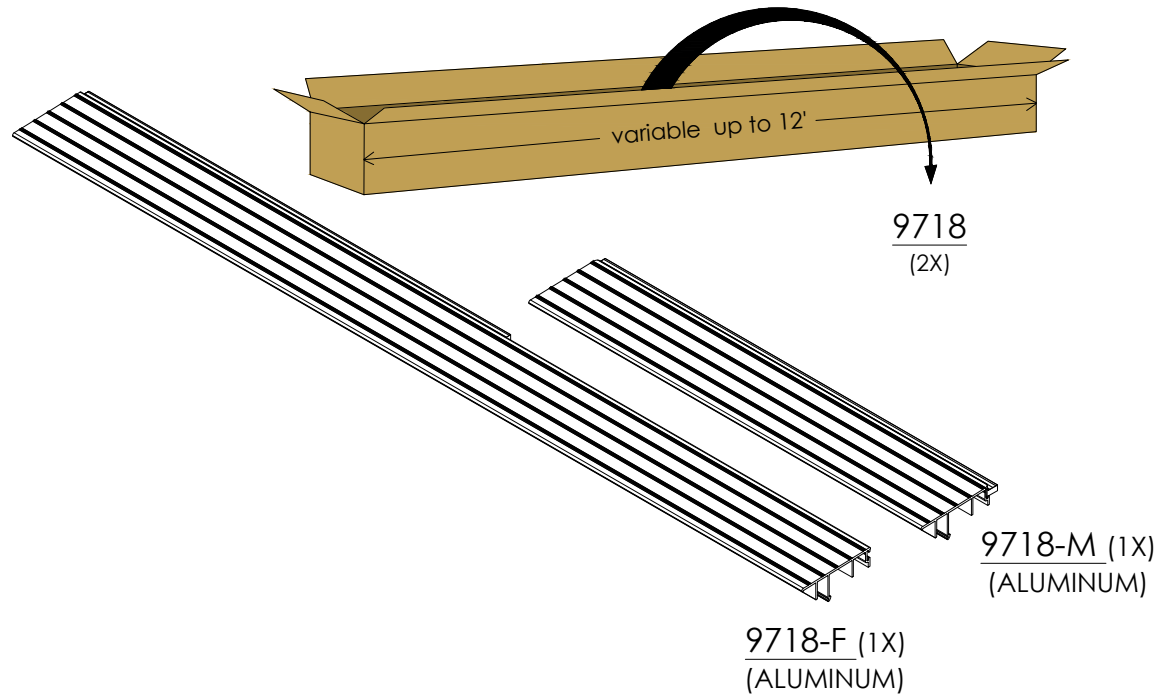



(Continued) Installation of Sills Covers

INSIDE View

GAP required for jamb cover (About 1/8" [13mm])

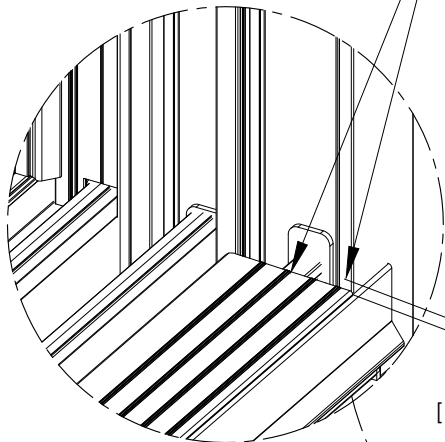

1/8" [13mm]

OUTSIDE View

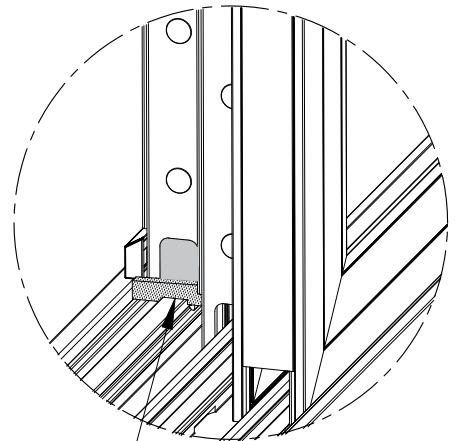
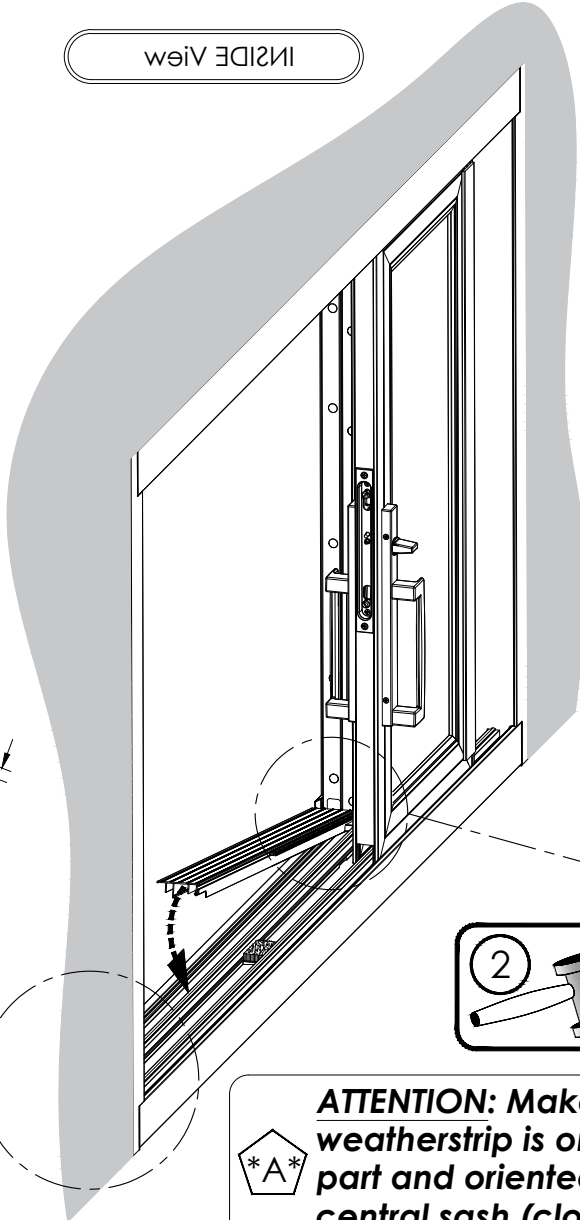
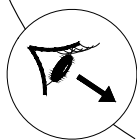

1 INSURE TO COMPRESS THE FOAM

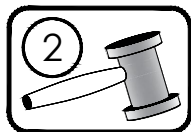

9718-F

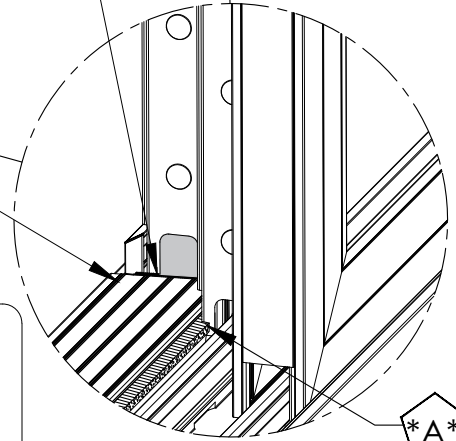

ATTENTION: Make sure weatherstrip is on half of the part and oriented towards the central sash (closed position).





STEP: 18

(Continued) Installation of Sills Covers

REVISION: 2021/03/10

PAGE: P64

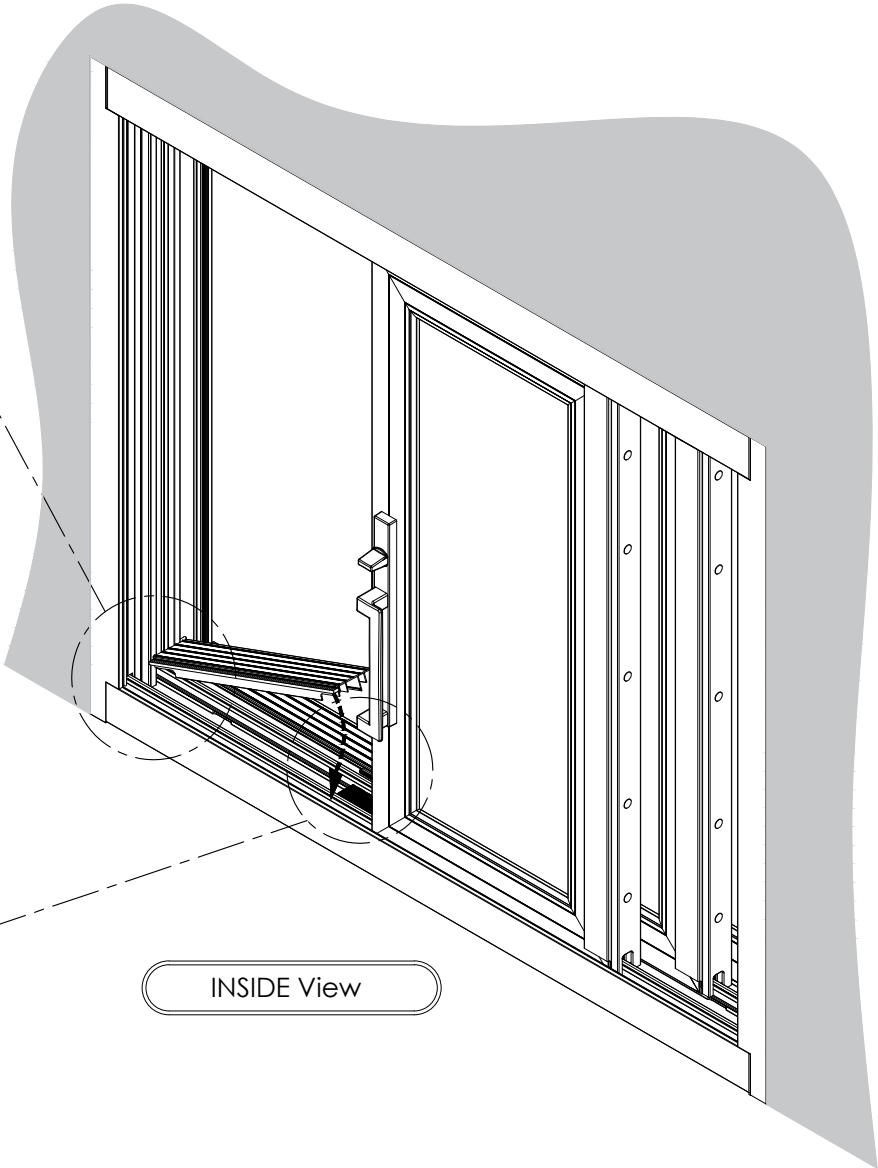
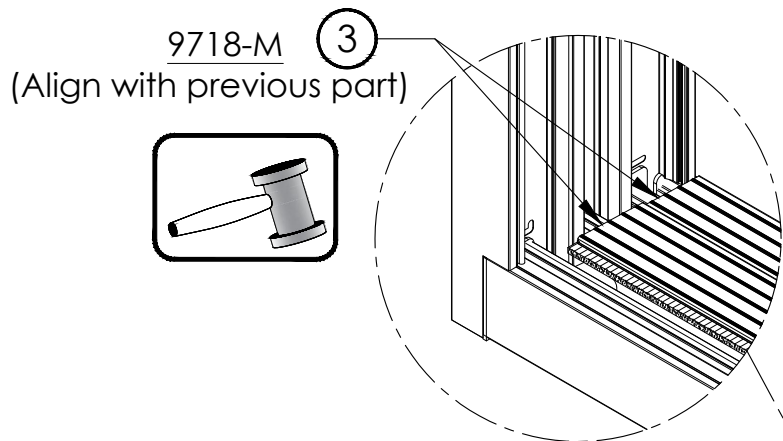

ATTENTION:
 A Verify that the fabric fin of the long part (9718-F) is not stuck behind the small part (9718-M).

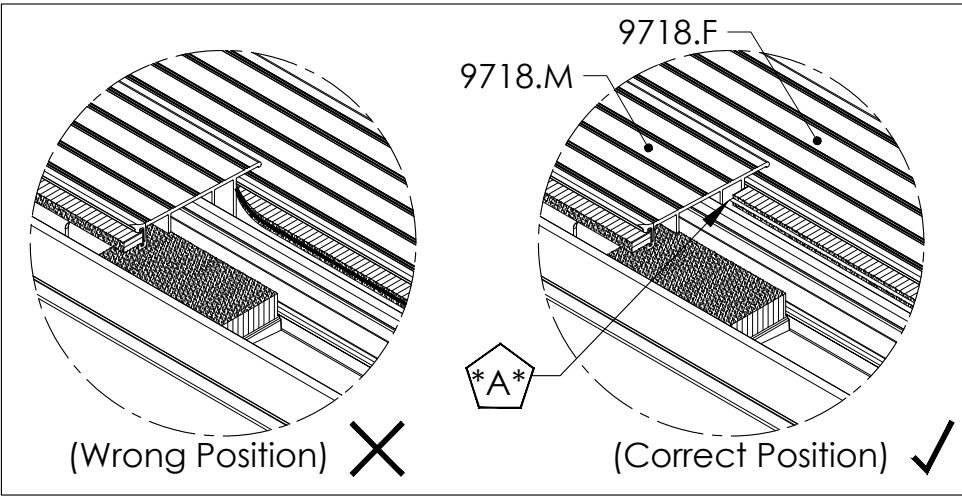



Installation of Water bar

*Tools and components required for this step **

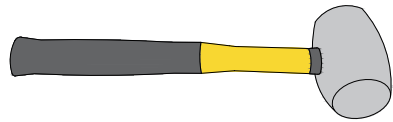

Rubber Mallet
(1X)

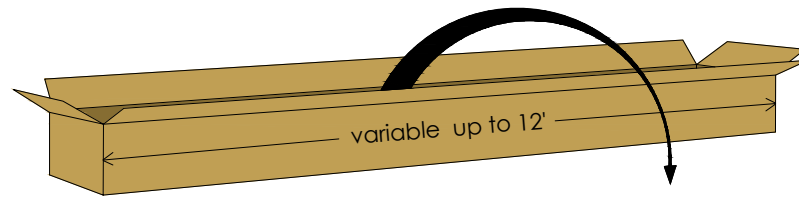

8390
(ALUMINUM)
(1X)



Impact
(1X)

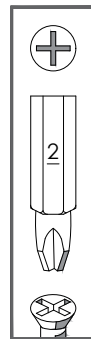

Screwdriver Bits
(1X)

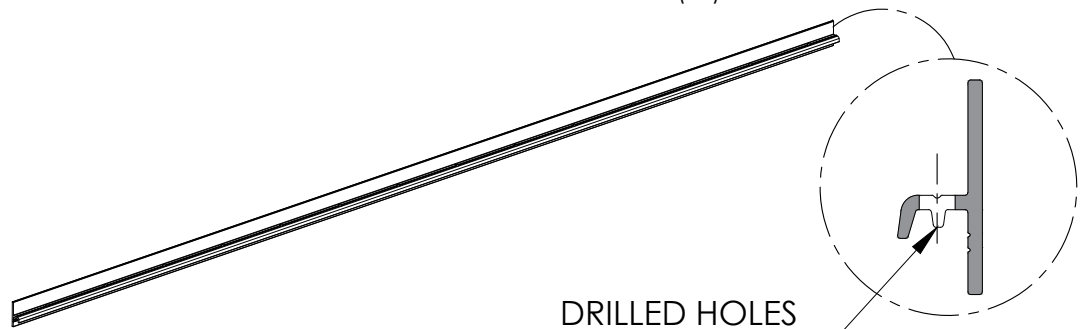

DRILLED HOLES
(SEE P10)

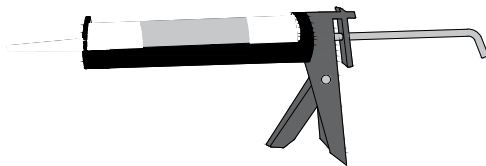

Compatible Sealant
(min.1X)

 08385.54.EXTRA.3V: EXTRA Bag - IMPACT

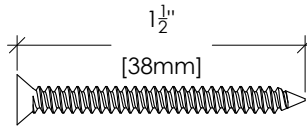
  9752.SS.VIS06
(13X)



STEP:
19

(Continued) Installation of Water bar

REVISION:
2021/03/10

PAGE:
P66

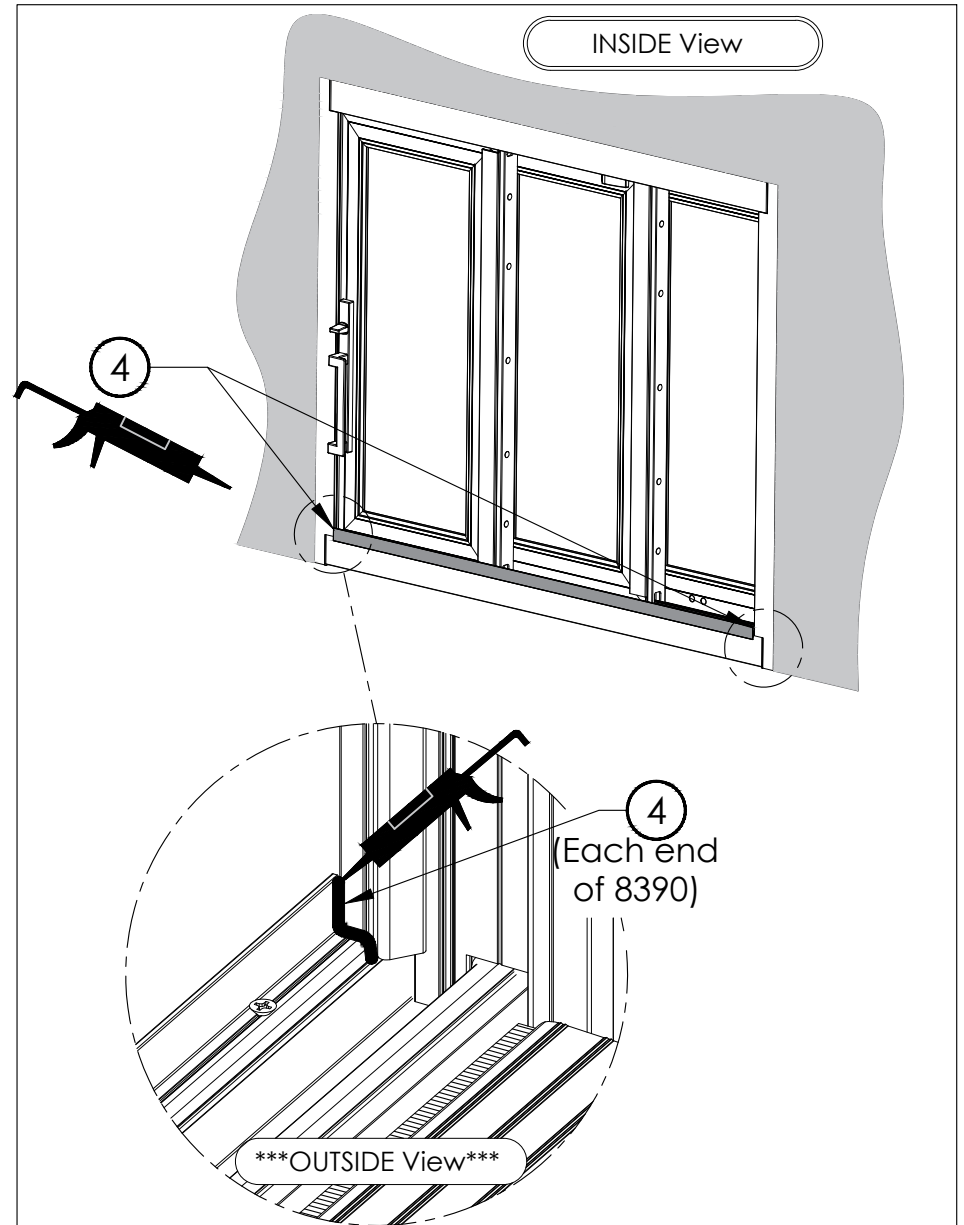
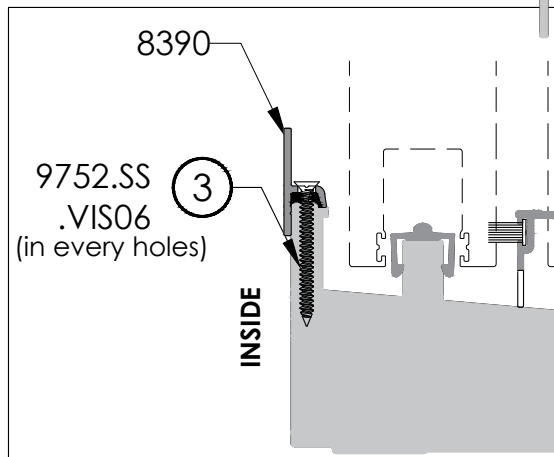
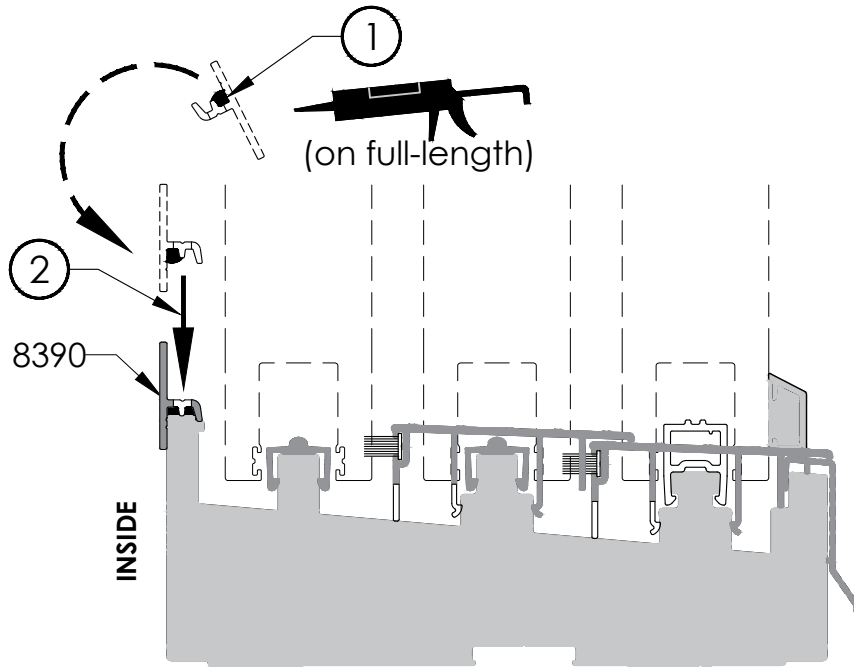



Installation of Jamb Cover (Outside)

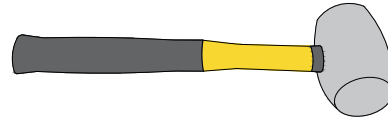
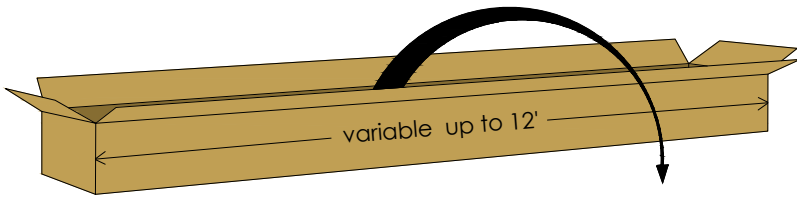

Rubber Mallet (1X)

1

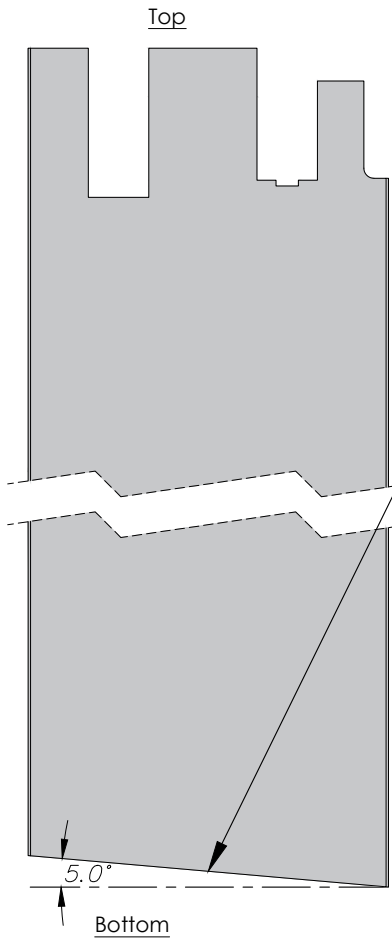

8313.(DE)

OUTSIDE View

INSERT BEHIND ALUMINUM SILL PROTECTOR

2

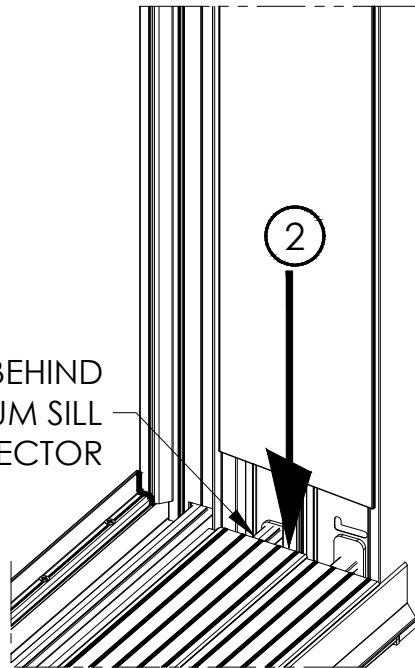

3 MOVE 8323 TO CREATE A GAP & INSERT BEHIND

3

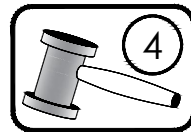
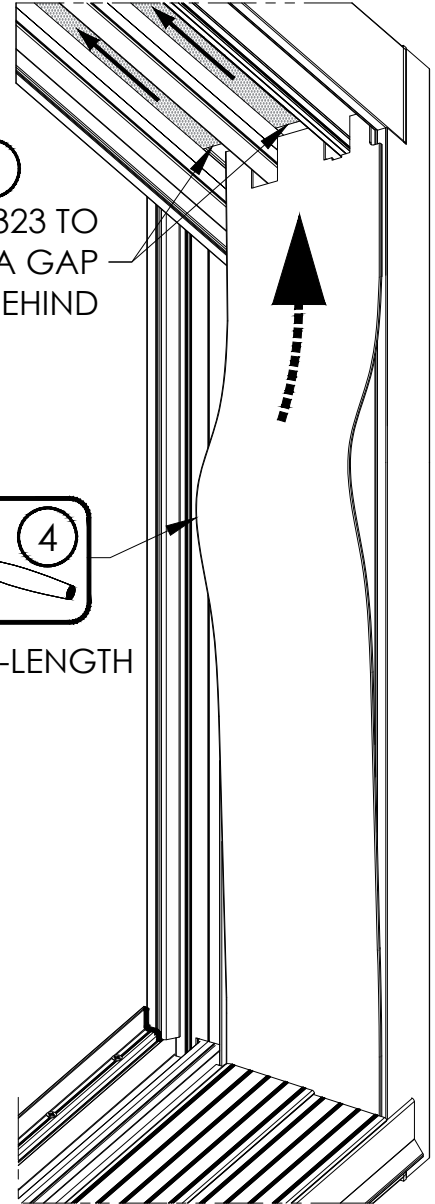

4

ON FULL-LENGTH

STEP:
21

CELESTA Impact Multi-Track Patio Door S-8385 [OXX]

****OPTION** - Preparation for RETRACTABLE SCREEN Installation**REVISION:
2021/03/10PAGE:
P68*****OPTION*******(IF A RETRACTABLE SCREEN IS PROVIDED WITH THE DOOR, FOLLOW NEXT PAGES FOR OPTIONAL PREPARATION BEFORE SCREEN INSTALLATION)**



STEP: **21**

****OPTION** - Preparation for RETRACTABLE SCREEN Installation**

REVISION: 2021/03/10

PAGE: P69

IMPORTANT: ONLY NECESSARY IF DOOR IS WITH SCREEN.

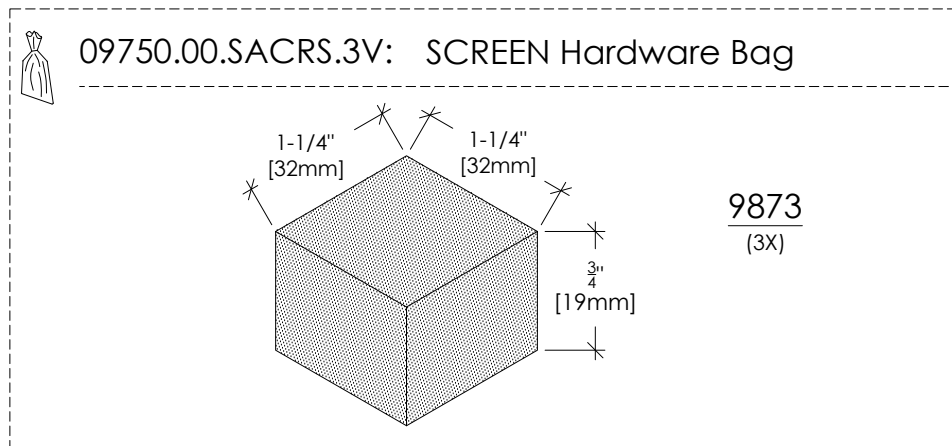
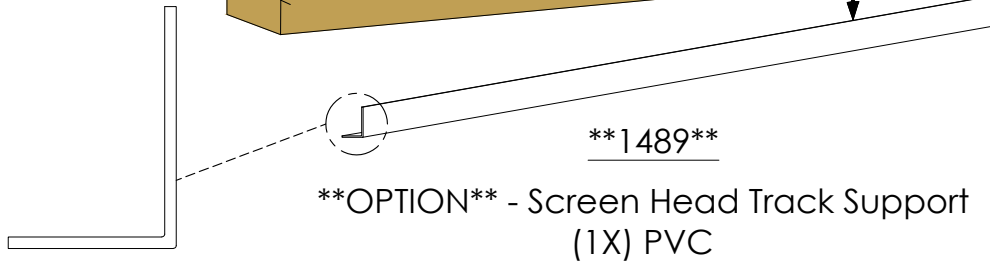
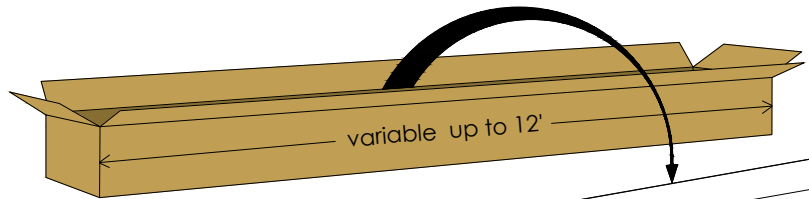
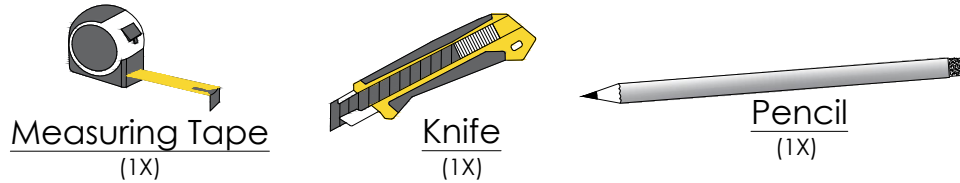

*****OUTSIDE View*****

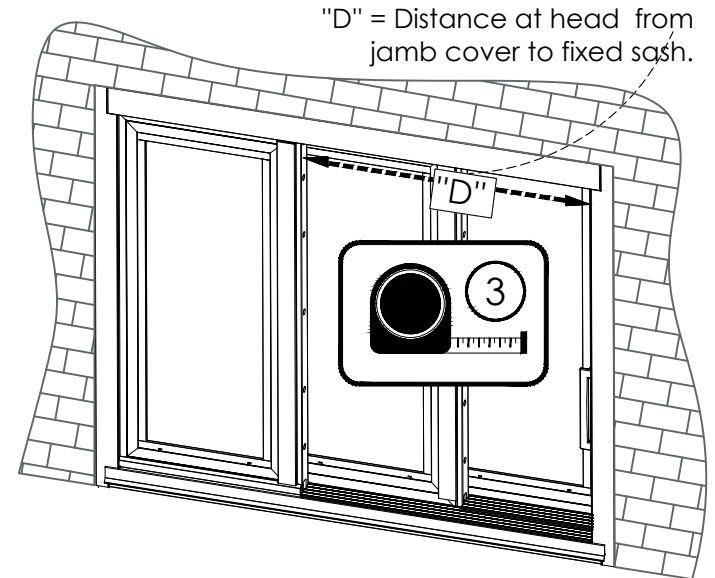



STEP:
21

****OPTION** - Preparation for RETRACTABLE SCREEN Installation**

REVISION:
2021/03/10

PAGE:
P70

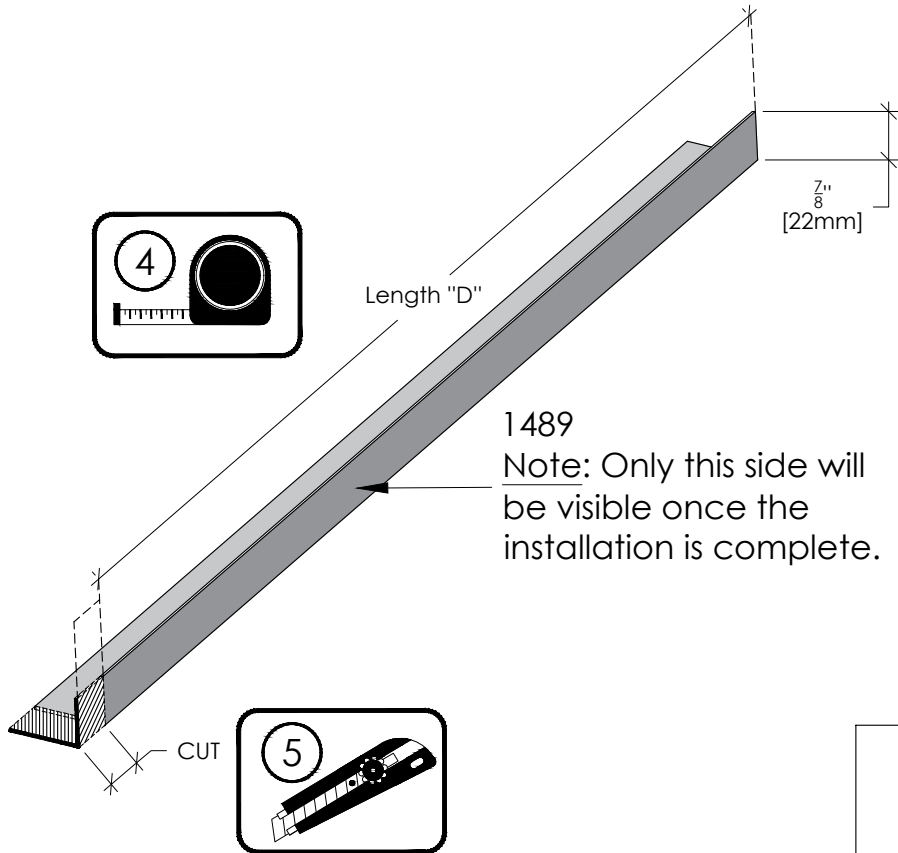

1489
Note: Only this side will be visible once the installation is complete.

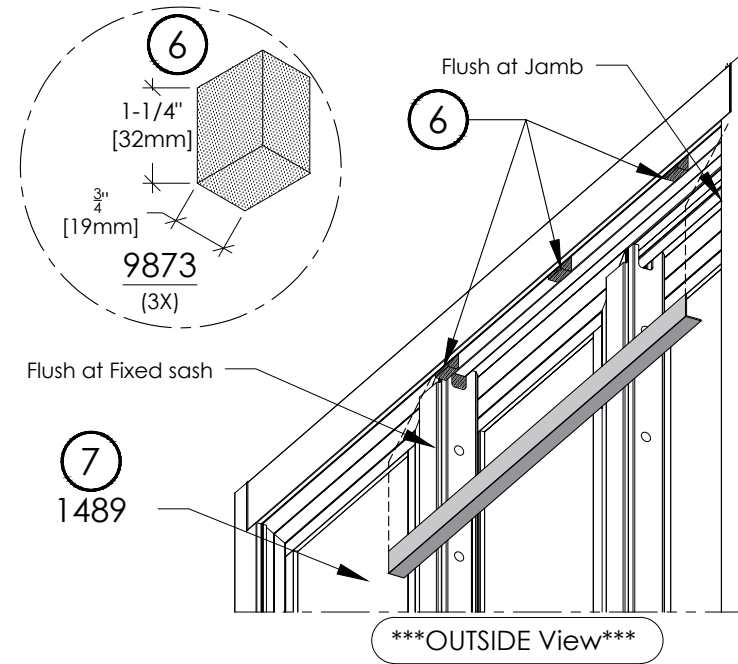

A
Be sure to continue installing the screen, as the 1489 could fall if not held by the screen head track (See supplement 9950.00.GI.8300.3V.RS)

