

Robo**Labs**

Incredible machines for funfood & fastfood

OPERATION MANUAL

COTTON CANDY MACHINES

ROBOJETFLOSS (ACB-09-120)

ROBOJETFLOSS PRO (ACB-09-120-PRO)

ROBOJETFLOSS RENT (ACB-09-120-R)

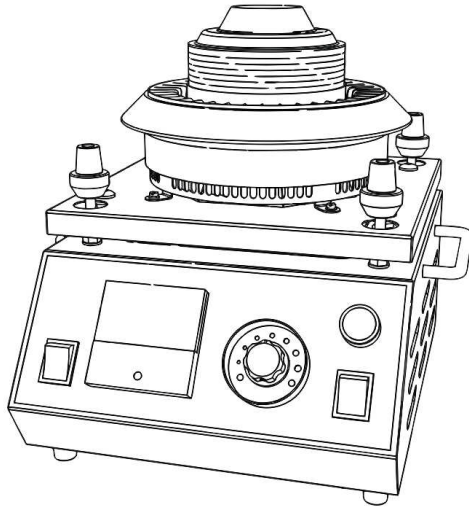

2018

SAFETY REQUIREMENTS



Read the ENTIRE MANUAL before operating.

Only allow TRAINED PERSONNEL to operate the Robo JetFloss.

1. DO NOT TURN ON until transport fastening nuts are fully RAISED.
2. DO NOT OVERFILL spinning head with flossugar.
3. WEAR eye protection during operation.
4. DO NOT TOUCH head while it is still rotating.
5. Spinning head remains HOT after use - DO NOT TOUCH until cool.
6. Avoid OVERHEATING, motor should rest 15 min. per hour of operation.
7. Do not MODIFY the design of the machine.
8. UNPLUG the power cord before cleaning or servicing.



In accordance to EN 60335-1:2012 standard the machine can be used by children aged 8 years and above and persons with reduced physical, sensory or mental capabilities or lack of experience and knowledge if they have been given supervision or instruction concerning use of the appliance in a safe way and understand the hazards involved. Children shall not play with the appliance. Cleaning and user maintenance shall not be made by children without supervision.

1. OVERVIEW AND OPERATION

1.1. DESIGNATION

ACB-09-120 is intended to produce cotton candy using sugar with or without flossine. Due to the patented design, the equipment allows operation under high ambient temperature and relative humidity. Candy floss leaves the machine vertically, producing servings up to 6 feet in diameter. With practice, you can move up to 16 feet away from the machine and continue to make candy as the stream will follow you in a continuous trail!

1.2. TECHNICAL SPECIFICATIONS

<i>MODEL</i>	<i>ROBOJETFLOSS ACB-09-120</i>	<i>ROBOJETFLOSS PRO ACB-09-120-PRO</i>	<i>ROBOJETFLOSS RENT ACB-09-120-R</i>
Productivity	up to 11 lbs/hr	up to 11 lbs/hr	up to 11 lbs/hr
'Cold start' time	60 sec	20 sec	60 sec
Spinning rate	3300 rpm	3300 rpm	3300 rpm
Rated current, not more	16 A	16 A	12 A
Rated voltage	120V/60Hz	120V/60Hz	120V/60Hz
Dimensions (machine only)	15x16x15 in	15x16x15 in	15x16x15 in
Dimensions (pan included)	26x26x19 in	26x26x19 in	26x26x19 in
Weight, not more	33 lbs	33 lbs	33 lbs

The RoboJetFloss will produce results at ambient temperatures up to 104°F (41°C) with relative humidity no greater than 50%. As relative humidity increases the maximum operating temperature decreases. For example, with a RH of 90% the maximum recommended temperature decreases to 68°F.

As temperature and humidity increase above these ranges, cotton candy can still be produced, but it will be very dense and heavy. Most importantly, being a sugar product, it may begin to melt shortly after being production.

Altitude above sea level should not exceed 3280 ft.

Ingress protection rating IP20 (IEC 60529).

1.3. DELIVERY SET

Delivery set of ACB-09-120 includes the following:

Cotton candy machine	1 pc
Plastic/aluminum floss pan ¹	1 pc
'No-Snow' tool	1 pc
Silicone sealing collar	1 pc
Silicone adjustment ring	2 pcs
Power supply cord	1 pc
Operation manual	1 copy



THE FLOSS PAN IS AN INTEGRAL PART OF THE MACHINE AND MUST BE INSTALLED FOR SAFE OPERATION!

Plastic/aluminum floss pan dimensions are 27" x 27" x 10" with net weight of 3.3 and 4.4 lbs respectively.

1.4. MACHINE DESIGN AND OPERATION PRINCIPLE

The RoboJetFloss includes the following main components: Housing (1); Chassis (2) with electric motor and Spinning Head (3). The spinning head and electric motor are mounted on the chassis, which itself is connected to the housing by four spring-mounted supports (6). These spring supports dampen vibrations and allow the motor to self-balance during operation.

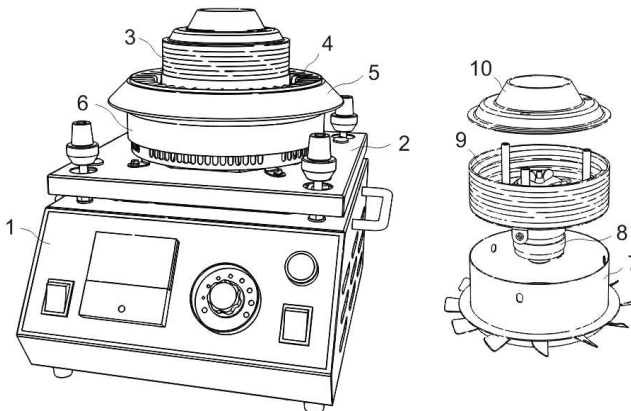

¹ ACB-09-120-R machine delivery set includes aluminum pan

Plastic/aluminum pan (18) is not shown.

An electric motor drives the spinning head at high rate (see Technical Specifications). A Stator (4) is mounted on the chassis to direct air flow in an upward spiral. It is fitted with a silicone Sealing Collar (5) which seals the gap between the floss pan and the stator in order to prevent sugar from falling onto the chassis. An adjustable Silicone Ring (6) is also attached in order to regulate the air flow.

The Spinning Head has the following main parts: Impeller (7); Base-plate (8); Sidewall with heating element (9) and Cover (10).

OPERATING PRINCIPLE

The spinning head rotates with the sugar mix inside where the heating element warms the sugar up to its flow point (250-285°F). Due to centrifugal force, the melted sugar flies through slits in the sidewall, where it instantly cools and crystallizes, turning into candy floss.

An attached impeller rotates along with the spinning head, producing a powerful upward airflow. Air enters from below through the axial holes of the stator where it can be regulated by the silicon collar.

The airflow lifts the cotton candy 3 ft. or more upwards. Sugar particles that are too heavy accumulate on the inner surface of the floss pan (not shown).

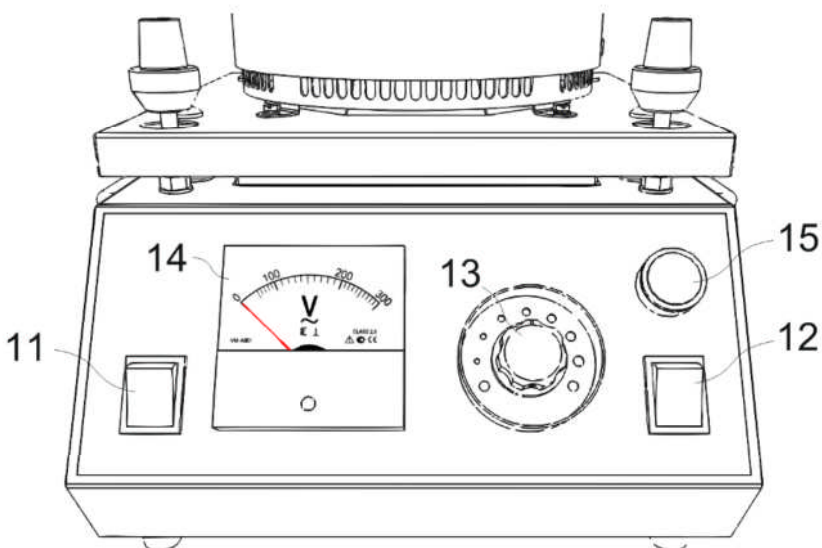

The front panel has the following controls: Switch (11) turns on the electric motor which rotates the spinning head; Switch (12) turns on the heating element; Adjustment Knob (13) regulates power to the heating element and thus controls its temperature; Voltmeter (14) indicates actual voltage supplied to the heating element.

The 'PRO' version includes a 'Quick Start' button (15) which temporarily sends maximum power to the heating element, even when the electric motor is not running.

See the figure above for ACB-09-120 front panel. Appearance may vary depending on your specific model.

2. INTENDED USE

2.1. PROTECTORS AND LOCKUPS

Four nuts secure the spring-loaded chassis during transportation to prevent damage to the motor. They are located on the threaded support studs at each corner of the deck.

Rubber legs and a spring suspension supports the chassis in order to minimize vibration and allow the spinning floss head to balance itself at high speed.

The stator prevents operators and objects from coming into contact with the rapidly rotating impeller.

There is a 16A circuit breaker provided for short circuit protection.

2.2. PREMISES REQUIREMENTS

The equipment may be operated in temperatures ranging from +41° F to +104° F with relative humidity not exceeding 50% at 104° F.

2.3. RAW MATERIAL REQUIREMENTS

Use only 100% pure sugar (beet or cane) with flossine or ready to use flossugar. Do not use sugars with starch, dextrose or similar additives as they can result in poor quality floss and/or clog the heater coil assembly.

2.4. GETTING STARTED

Unpack machine and save packaging for future shipping.

Put the machine on a stable table or cart.

Before attaching power cord, fully raise all four transportation fastening nuts (16) until they reach the rubber floss pan supports.

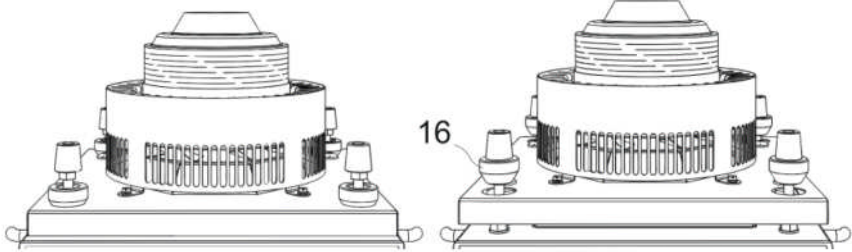

Transportation position

Operation position



TURNING ON THE MACHINE WITHOUT RAISING FASTENING NUTS WILL RESULT IN MACHINE FAILURE!

Wash silicone ring and silicone collar with dish soap. Carefully install silicone ring on the stator. Adjust the exposed gap on the stator intake to regulate airflow depending on ambient conditions.

For indoor operation (70° F and 50% RH) minimize airflow by exposing no more than ½ inch of the intake grill

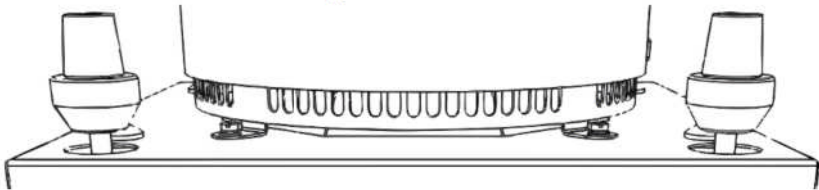

Next, remove the thin protective film from the Floss Pan and wash with dish soap. Place the pan on the machine making sure the indentations rest on the four rubber support legs.

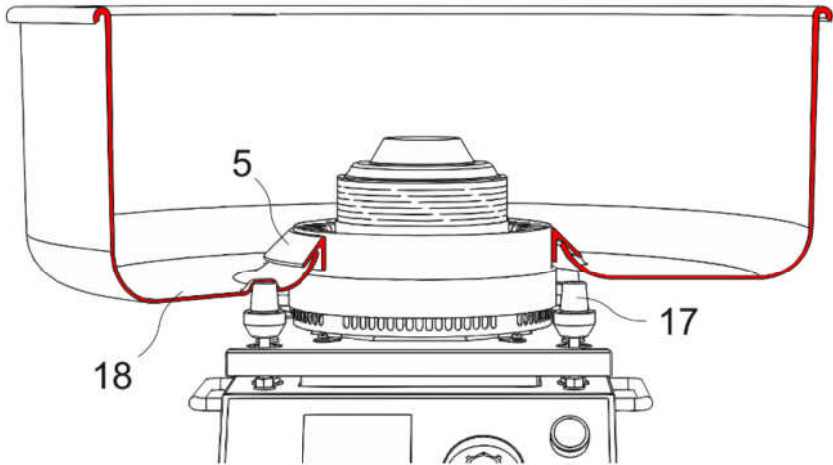

Floss pan indentations (shown above) should fit rubber support legs (17). carefully install silicone collar (5) on the stator with the collar edge overlapping the pan.

2.5. POWER SUPPLY REQUIREMENTS

Input current does not exceed 16 A (12A for ACB-09-120-R machine).

The machine is equipped with 6 ft power cord with NEMA 5-20 standard plug or NEMA 5-15 plug (for ACB-09-120-R only).

The machine requires standard 120V power supply. Voltage tolerance of +/-10% of nominal voltage is allowed.



MACHINE MUST ONLY BE CONNECTED TO A GROUNDED OUTLET!



CAUTION! – RISK OF FIRE AND ELECTRIC SHOCK!
 REPLACE ONLY WITH MANUFACTURER'S CORD SET, PART NO.
 PF52012C1972 or PF51514C1972 (for ACB-09-120-R ONLY!)

2.7. OPERATION MODE

Before turning on the machine, first add 1½ cup flossugar to the spinning head, or approximately ¾ full. The minimum recommendation is 1/3 full at all times. Quickly rotate the head manually to distribute the sugar evenly.

You will need sticks, rods or cones to spin above the machine to collect the cotton floss as it is produced. These can be made of wood, paper or plastic. The longer the sticks, the larger the servings of cotton you can create. For the Robo JetFloss the ideal length is 1 ½ ft – 2 ft..

Wood sticks and plastic straws should be soaked in water first in order to create better adhesion for the floss.

Turn the main power switch (11) ON and the spinning head will begin to rotate.



VIBRATION OF THE SPRING MOUNTED CHASSIS DURING FLOSS HEAD ACCELERATION AND DECELERATION IS NORMAL.

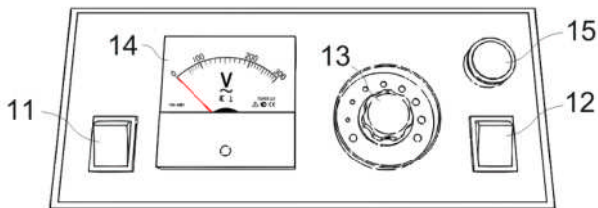

Next, turn on the heater coil power switch (12), and use the adjustment knob (13) to set voltmeter² (14) to between 70-80 V.

Depending on conditions, it will take about 1 minute to warm up the head to operating temperature. You will usually smell the candy aroma between 10 to 15 seconds before production begins.

Cotton candy will fly out upwards in a vertical column or “sleeve.” This “sleeve” can be wrapped or wound around a stick by rapidly turning or spinning the stick with your fingers in a clockwise direction (see below).

You will usually want to collect floss between 8” to 14” above the spinning head, though you can adjust for conditions and the size of the serving.

If you find airflow is too strong or weak, turn off the machine and adjust silicone band on the stator (see Air flow adjustment section below).

² When setting up at a new location, the power level must be adjusted according to the environmental conditions. If cotton candy comes out too slow, increase the voltage slightly. Alternatively, decreasing voltage will slow production. When you change locations or if the temperature or humidity changes later in the day (if working outdoors) then you may need to make additional adjustments.



'Cold start' Procedure

When the Robo JetFloss has been off for more than 15 minutes, it will take at least 60 seconds before the heating coil has warmed enough for the production of cotton candy to begin. If the machine has only been off for a brief time, such as to add more flossugar, this time will be reduced substantially.

Users of the 'Pro' version can press and hold the 'Quick start' button (15) for 10 - 15 seconds. This will send full power to the heating element and can be done whether the main power switch is on or not. This will substantially reduce the time required to begin candy production.

Owners of the standard version can achieve a similar result by manually adjusting the voltage regulator. After switching on both the motor (11) and heating element (12), an experienced operator can adjust the voltage regulator to the maximum (13). But, again for only 10 – 15 seconds, and then decreasing the voltage back to the recommended operating range between 70-80 V and proceeding as normal from there.

However, in neither case above should maximum voltage be applied for more than 10 -15 seconds as you risk overheating the element and burning

the flossugar. Doing so could result in overheating the flossugar and the the cotton candy would then be produced in a narrow rope that is difficult to capture. In an extreme scenario, the floss would be burnt and ejected as irregular flakes and sugar dust that would create a mess covering everything nearby in the immediate area.

The figure below shows an example of mildly overheated heating element. Notice the cotton candy is rising more like a 'rope' than a wide "sleeve."

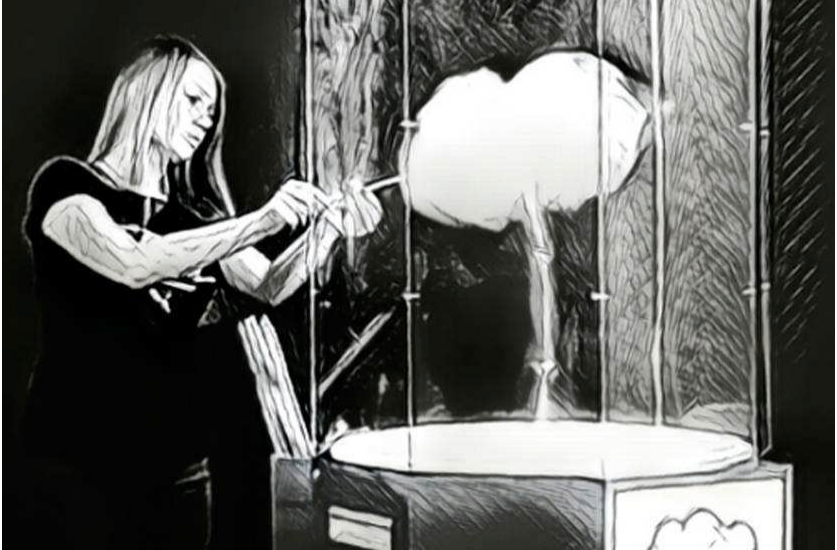

Keep in mind that once the heating element and sidewall have reached such a high temperature, reducing the voltage will not immediately produce the desired effect. Due to thermal lag, any changes in voltage will only slowly take effect over the next 15 to 30 seconds (or longer, depending on ambient temperatures) so it is very important to avoid overheating the element in the first place.

'No-Snow' Tool

In the production of cotton candy, "snow" includes flakes, flecks, small filaments and sugar dust that are all too small to be collected in the normal winding process of producing a cotton candy serving.

There are four situations when "snow" will be emitted from the spinning head:



At the very beginning of operation.



During the end of production.



When there there is not enough flossugar remaining.



If the coil and sidewall are overheated.

In both the beginning and ending of operation, snow is produced as the heating element crosses the temperature threshold at which it can evenly and uniformly melt the flossugar in the bowl into quality cotton candy floss.

The same is true when there is not enough flossugar left in the head because the remaining sugar will not be evenly distributed and that will cause some of the material to overheat. Keeping the floss head at least 1/3 full at all times will prevent this from occurring.

Finally, if the coil and sidewall become extremely overheated then brunt sugar flecks and dust will be produced instead. Paying attention to Voltage regulation and not excessively preheating the coil during cold startup will ensure this does not happen.

Regardless of the cause, you can prevent the distribution of snow (which can create a mess) by placing the 'No-Snow' tool (26) over the spinning head, where it will capture the snow as it is ejected.

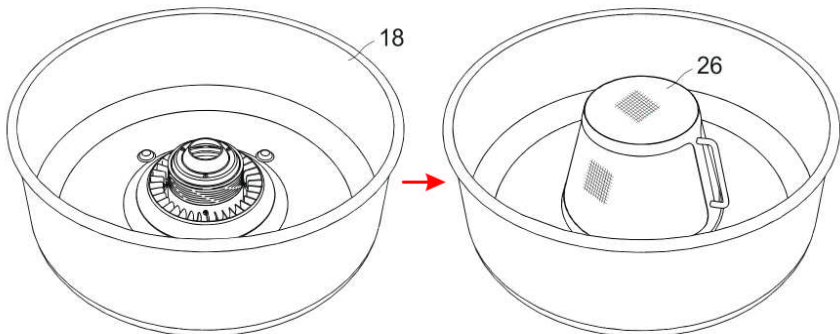

However, you should not leave the 'No-Snow' tool in place for long periods of time as it will eventually become filled with floss and this will then collect on the spinning head itself.

To help prevent this, the inside of the "No Snow" tool should be wiped off in between each use to prevent accumulation of spent flossugar.

If you do notice melted or burnt sugar accumulating on top or lip of the spinning head cover, or excessive buildup on the sidewall, then this should be scraped off before proceeding.

This can be done using a wooden bamboo skewer or stick (never metal) while the head is spinning. Gently put the tip of a stick into the inner right-side edge of the cover and allow the rotation of the head against the stick to scrape off any sugar accumulation. This can be repeated on the outside of the sidewall as well, again only on the right-side of the spinning head.

This cleaning should not be done when customers are nearby as small pieces of sugar could fly some distance and pose a risk to the face and eyes.

Air Flow Adjustment

When operating indoors, air flow should be kept to a minimum. The silicone band should cover the stator intake grill almost completely, exposing only 1/3" – 1/2" at the base per the figure below.

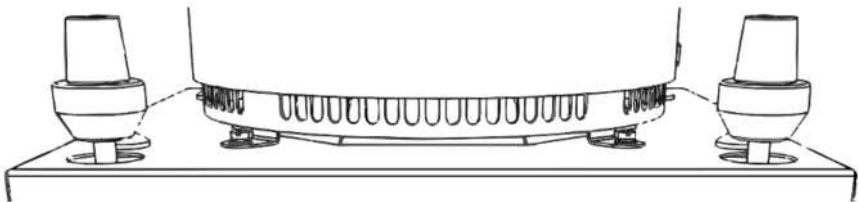

As you expose more of the intake grill, the intensity of the airflow will increase. This is useful for performing tricks and also for outdoor operation where humidity will make for denser and heavier cotton candy and wind may also be present.

However, with increased airflow it becomes more difficult to make servings efficiently, so minimal airflow is preferred when speed is desired. During setup some experimentation will be required as conditions vary. Removing the sleeve entirely is common when working outdoors, in warm and humid weather, as pictured below.

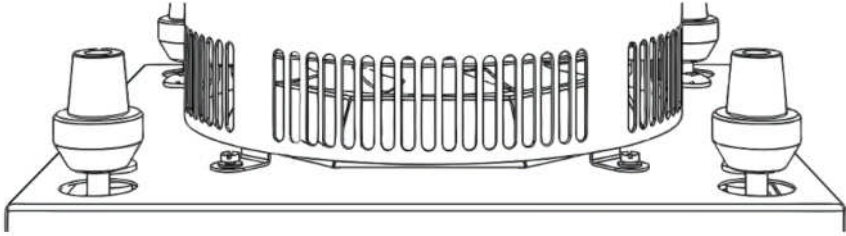

Vertical flow machine operation recommendation

ACB-09-120 has high production rate, and is intended for prolonged operation.

Only vertical flow machines allow you to perform entertaining tricks when making cotton candy. The most common technique is forcing the candy sleeve to follow you several feet away from the machine like a “snake” or animated rope.

The “snake” trick requires plenty of space and is generally performed outdoors when there is enough humidity in the air to create a dense sleeve of candy floss.

Once you have made a small cloud on the stick, pull it smoothly away from the machine (see the figure below). Keep winding the cotton candy, and do not let it to fall below the floss pan. Be careful, as winding too rapidly might break the sleeve.



By moving move your hands up and down and changing the angle of the

stick, you will find that you can modify the shape of the snake.

Once you have the hang of it, you will be able to step away from the machine, as far as 10' to 15' (depending on conditions) and the snake will follow you if you continue the proper winding rate.



You can find more information at www.flyingcottoncandy.com

Shutting Down

When shutting down for periods of less than 24 hours, you may leave any remaining flossugar in the spinning head.

Turn off power to the heating element switch (12) and capture the remaining cotton candy as the head cools down. When the coil cools to the point that “snow” is produced, then cover the head with the “No Snow” tool and allow the head spin for 5-7 minutes to fully cool down before turning off the main power switch (11).

Once cool to the touch, wipe out the inside of the “No Snow” tool, and put it back over the spinning head for protection. You can also cover this with a paper or plastic bag to protect the flossugar from dust, debris and insects.

The machine and Floss Pan should be wiped down with a damn cloth to remove excess flossugar as needed.

If you are shutting down for longer than one day, then you should perform a complete cleaning of the spinning head as described in the Technical Maintenance section below.

Do not leave unused flossugar in the spinning head for more than a day or two as it can harden/caramelize and effect the balance of the head during future sessions, which could ultimately result in failure of the machine.

During transportation always secure the chassis using the transportation lock-down nuts. This will prevent possible damage of the machine and prolong the lifetime.

3. TECHNICAL MAINTENANCE

3.1. GENERAL INSTRUCTIONS



ATTENTION! THIS PART OF OPERATION MANUAL IS INTENDED ONLY FOR TRAINED PERSONNEL EXPERIENCED WITH ELECTRICAL EQUIPMENT.

The purpose of technical maintenance is extend the working life of the machine while fulfilling all safety requirements.

The following schedule³ is recommended:

<i>PROCEDURE</i>	<i>PERIOD</i>
Cleaning machine and pan surfaces removing sugar and cotton candy	Once a day
Sidewall and heater cleaning	Twice a month
Brush unit maintenance	Every 6 months

3.2. SAFETY MEASURES



DO NOT CLEAN THE SPINNING HEAD OR COMPONENTS WITH SHARP OR METAL PARTS. HOT WATER, A SPONGE OR SOFT BRISTLE BRUSH IS ALL THAT IS REQUIRED OR PERMITTED!



DISCONNECT THE POWER SUPPLY BEFORE CLEANING OR PERFORMING TECHNICAL MAINTENANCE!

³ Technical maintenance may be required sooner if individual parts become fouled prior to scheduled service.

3.3. TECHNICAL MAINTENANCE

Spinning head cleaning

During long-term operation, the heating element and sidewall slits can become clogged with sugar and carbon deposits. This may significantly reduce both productivity and the quality of the cotton candy produced.

To clean the sidewall and heating element it is necessary to disassemble the spinning head, remove the heating element and sidewall and wash them carefully with hot water.

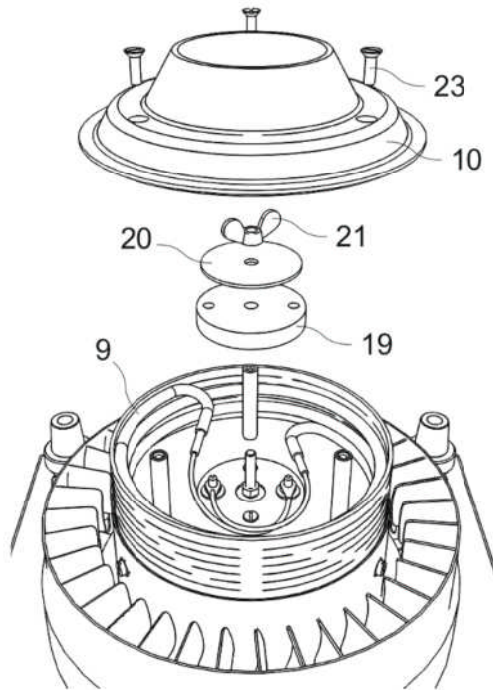

To disassemble the spinning head:

1. Remove all sugar from the head, turning the machine upside-down if necessary.
2. Detach floss head cover (10) by removing three flat-head screws (23).
3. If the cover is 'glued' to the sidewall, gently tap with the screwdriver

handle in order to loosen the parts.

The sidewall is made of high-grade stainless steel. Nevertheless, the part might be damaged by excessive tightening the screws, by throwing, or by heavy impact.

4. Remove central wing nut (21), steel washer (20), plastic holding washer (19). Then, using a 7mm nut driver or wrench, remove the nuts that are securing the wire ends to the terminal posts. Remove the nuts, lock washers, terminal ends and washers and you can then lift off the sidewall with heating element (9) as one unit.

5. Wash the sidewall and heating element with very hot water in order to melt the flossugar. When the bulk of the flossugar is removed, carefully separate the heater coil from the sidewall to clean the areas where they contact one another.



DO NOT IMMERSE HEATING ELEMENT TERMINAL LEADS IN WATER AS THIS MAY CAUSE FAILURE!

6. The sidewall and heating element must be dry before reinstalling.



ABRASIVE OR MECHANICAL CLEANING OF HEATING ELEMENT AND SIDEWALL IS PROHIBITED!

Re-assembly of the spinning head is done in the reverse order. Once completed, turn on the motor and power to the heating coil for approximately 30 seconds in order to spin off any remaining moisture.

Brush unit maintenance

As with most electrical motors, the Robo JetFloss utilizes brushes and slip rings which are subject to wear and require inspection, maintenance and eventual replacement.

To inspect and maintenance the brush unit it is necessary to take off the stator (4) by removing the four fastening screws. Next remove the impeller (7) by removing three fastening screws.

Inspect the slip rings (24) for bumps and color changes. The rings should fit closely to insulators and should not show excessive wear.

Slip rings are made of high-grade brass and will last years if properly serviced.

If the slip rings are excessively worn or are covered with bumps, they need to be replaced by qualified service staff.

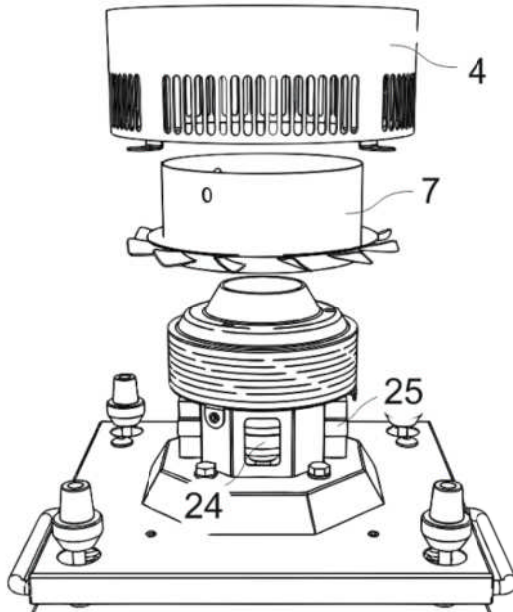

To replace brush units (25) first remove the screws securing the brush unit. Remove the unit carefully and inspect the carbon brushes. If the brushes are worn more than half of the length, they should be replaced.



AFTER BRUSH UNITS ARE REPLACED, REMOVE ALL DUST, DEBRIS AND TARNISH FROM THE SLIP RINGS (24).

After installing new brushes, allow the motor to run for 15 minutes before turning on the heating element. This will allow the brushes to conform to the slip rings, avoiding the potential for arcing under load.

3.4. STORAGE

If the unit is not used for a prolonged period of time, then the routine maintenance must be performed before it is placed back into service.

3.5. TROUBLESHOOTING



DISCONNECT THE POWER SUPPLY BEFORE DIAGNOSTICS AND REPAIR. EMI FILTER MUST BE DISCHARGED BY CLOSING ALL THE PINS IN THE PLUG!

<i>FAILURE</i>	<i>POSSIBLE CAUSE</i>	<i>REMEDY</i>
Machine doesn't turn on when power switch is activated.	No power at the wall socket.	Use a tester to check the voltage on all phases. Provide power in the wall socket.
	Power supply cord is damaged.	Use a tester to check the cord for breakage, replace defective cord.
	Blown fuse	Use a tester to check the fuse, replace if necessary.
Motor is spinning, but the machine doesn't produce cotton candy.	Power regulator is out of order.	If voltmeter pointer doesn't move upon adjustment knob action, then replace the power regulator.
	The heating element is out of order.	Use a tester to check the heating element, replace if necessary.
	Brush unit damage.	Check the brush unit. Brushes must fit closely to the slip rings, without sparking. Replace the brush unit if necessary.
Low productivity.	Caramel sticking on the sidewall.	Clean the sidewall and heating element in accordance with instructions.
	Low voltage from the outlet.	Check the voltage from the outlet or extension cord. Low voltage is a frequent cause of low productivity.
Smoke from the spinning head.	Sidewall overheating.	Reduce the voltage on the heating element with adjustment knob.
	Power regulator is out of order.	If the pointer of voltmeter doesn't move during adjusting, replace the power regulator.
Significant vibration of the machine.	Spinning head imbalance.	Fill in the head at least $\frac{3}{4}$ full with flossugar and rotate the head manually to spread sugar evenly.
		Check the head for foreign objects.
		Check the head for caramel stuck on the heating element. Clean the sidewall and heating element in accordance with instructions.

4. TRANSPORTATION AND STORAGE

The equipment may be transported by any kind of covered vehicle, in accordance with local regulations.

Ambient temperature during the transportation and storage must be between -13° F and +131° F.

5. TEST CERTIFICATE

ACB-09-120 machine has met mandatory requirements of the state standards, actual technical documentation, and approved for use.

<i>TEST CERTIFICATE</i>	
<u>ACB-09-120</u> <i>Product Name</i>	_____ <i>Serial No.</i>
<i>The equipment is made with accordance to mandatory requirements of the state standards, actual technical documentation, and approved for use.</i>	
<i>QC Engineer</i>	
<i>STAMP HERE</i>	
_____ <i>Signature</i>	_____ <i>Full Name</i>
_____ <i>DD.MM.YYYY</i>	

6. WARRANTY OBLIGATIONS

The manufacturer guarantees trouble-free operation of the equipment during 12 months from the date of receiving the equipment by dealer (in accordance with transport documentation); or, in case of purchase directly through Business Russia LLC, from the purchase date, given that terms of using, transportation and storage are met.

The warranty repair is performed upon presentation of this manual and filled warranty card with the seller's seal and the date of sale.

Technical specifications of the equipment can be changed by manufacturer at any time due to improvements and/or other reasons. Technical specifications stated in this document are intended to act as a reference point, which is necessary to evaluate suitability of the equipment for the customer's needs, and are not the subject of warranty policy.

The information stated in this document has been thoroughly checked and considered as accurate one; nevertheless, the manufacturer is not responsible for any typographical errors or misprints.

Due to constant improvement of the equipment, technical specifications are subject to change without prior notice!

7. MANUFACTURER DETAILS

NPO Tvertorgmash LLC

11 Industrial Street, Tver, 170000 Russia

Technical support is available:

Email: support@robo labs.pro

Phone: +7 495 956 4000