

CRANE[®]

Energy Flow Solutions

Crane Cast Steel Valves



CRANE[®]

General Index

Ordering Information	4
Materials	5
General Data	6
Identification	7
General Features	8
Gate Valve Features	9
NACE Trim Steel Valves	13
Globe Valve Features	14–15
Swing Check Valve Features	19–20
Tilting Disc Valve Features	24–25
Stop Check Valve Features	31
Stop Check Valve Technical Data	34
Flow Data	35
Installation Recommendations	36
Pressure/Temperature Ratings	37–39

Crane also manufactures bronze ball valves, iron wafer and lug butterfly valves, bronze and iron gate globe and check valves, and alloy valves. Brochures and catalogs are available on request.

Figure Number Index

FIGURE NO.	VALVE TYPE	PRESSURE CLASS	CONNECTIONS	SIZE RANGE	PAGE NO.
28	Stop Check Valve	300	Flanged	3" – 10"	32
28½			Butt-Weld	(80 – 250 mm)	
30	Stop Check Valve	300	Flanged	3" – 10"	33
30½			Butt-Weld	(80 – 250 mm)	
33	Gate Valve	300	Flanged	2" – 24"	11
33½			Butt-Weld	(50 – 600 mm)	
47	Gate Valve	150	Flanged	2" – 24"	10
47½			Butt-Weld	(50 – 600 mm)	
76	Gate Valve	600	Flanged	2" – 12"	12
76½			Butt-Weld	(50 – 300 mm)	
123	Tilting Disc Valve	150	Flanged	2" – 36"	26
123½			Butt-Weld	(50 – 900 mm)	
143	Globe Valve	150	Flanged	2" – 12"	16
143½			Butt-Weld	(50 – 300 mm)	
147	Swing Check Valve	150	Flanged	2" – 24"	21
147½			Butt-Weld	(50 – 600 mm)	
151	Globe Valve	300	Flanged	2" – 12"	17
151½			Butt-Weld	(50 – 300 mm)	
159	Swing Check Valve	300	Flanged	2" – 24"	22
159½			Butt-Weld	(50 – 600 mm)	
171	Globe Valve	600	Flanged	2" – 8"	18
171½			Butt-Weld	(50 – 200 mm)	
175	Swing Check Valve	600	Flanged	2" – 12"	23
175½			Butt-Weld	(50 – 300 mm)	
323	Tilting Disc Check	300	Flanged	2" – 36"	27
323½			Butt-Weld	(50 – 900 mm)	
623	Tilting Disc Check	600	Flanged	2" – 30"	28
623½			Butt-Weld	(50 – 750 mm)	
923	Tilting Disc Check	900	Flanged	3" – 18"	29
923½			Butt-Weld	(80 – 450 mm)	
1523	Tilting Disc Check	1500	Flanged	2" – 10"	30
1523½			Butt-Weld	(50 – 250 mm)	

How to Specify and Order the Correct Valves

Care should be taken to select the most suitable steel valve for your service(s). Exact specification of each valve should be made to avoid ambiguity when requesting quotations or ordering the product.

Size

Nominal size of the pipeline into which the valve will be placed must be determined. Comprehensive data on flow characteristic and pipe properties are contained in the Engineering Data Catalog.

Valve Material

The following facts should be considered in determining the correct valve material.

- The media to be controlled.
- The temperature of the media.
- The possible extraordinary stresses affecting the valve.
- Safety standards and/or piping codes.

Type of Valve

A few minutes spent in reading some simple valve facts on pages 5 and 6 will prove helpful.

Pressure/Temperature Rating

Please pay careful attention that the PRESSURE/TEMPERATURE RATINGS shown on page 34 in this catalog are in keeping with the requirements of the service.

Valve End Connections

Considerations as to pipeline integrity, future maintenance, corrosion factors, field assembly, weight and safety should be given in determining the method of connecting the valve in the pipeline.

CAUTION: When servicing, disassembling or disposing of valves containing asbestos gaskets or packing, avoid breathing dust or fibers from these parts. Disposal of asbestos and asbestos related products should comply with local, state and federal laws and regulations.

Ordering Information

Designate the valve size and the complete catalog number, including prefix and suffix letters, when applicable, to identify regular cataloged items as described on the following pages.

Any special requirements such as Gear operation, Motor operation, Hydraulic or Pneumatic Cylinder operation, Anti-friction bearing yoke sleeve, By-Pass of drain, etc. must also be specified on purchase orders.

Examples

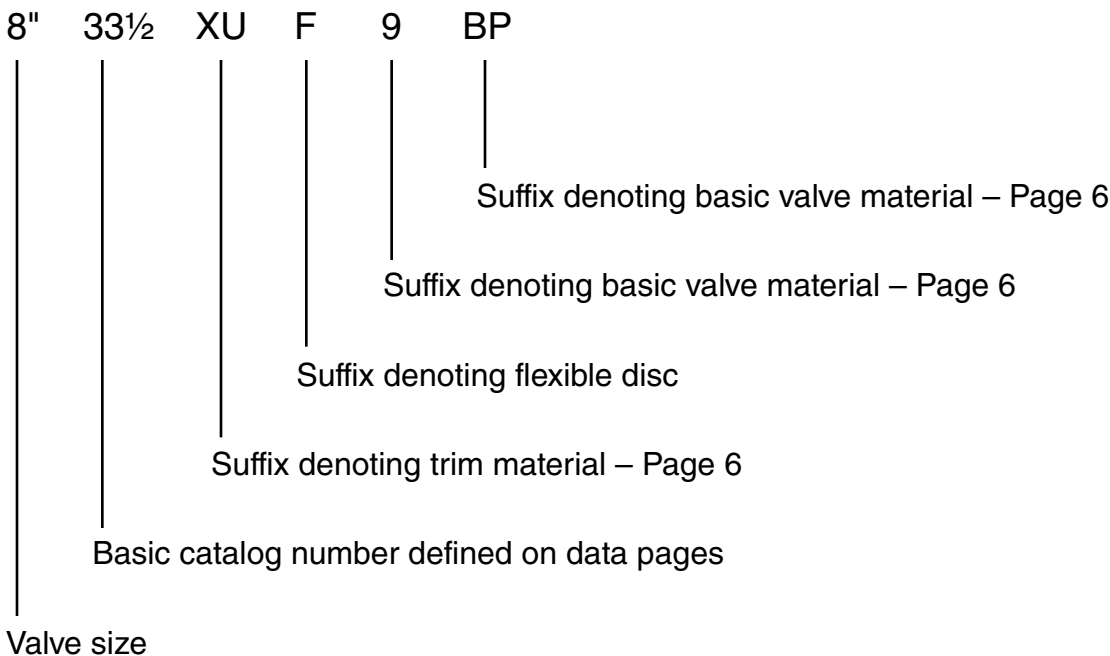

NOTE: In keeping with our policy of continuous product improvement, we reserve the right to institute changes in design, material, dimensions, and specifications without notice and without incurring any obligation to make such changes and modifications on the product previously or subsequently sold.

Materials of Construction

Steel bolted bonnet valves described in this catalog are typically manufactured of carbon steel. When specified, the valves are available in the alloys shown below which are suitable for steam, water, oil, oil vapor, gas and general services. Please contact factory or customer service for availability and material breakdowns.

Body and Bonnet or Cap Materials

Part No. Suffix	ASTM Classification	Material Classification	Service Conditions
None	A216 WCB	Carbon Steel	For service up to 800°F (426°C) where corrosion and oxidation are not a factor. (1) (4) (5)
6	A217 WC6	1 ¼ CR, ½ Mo	For service up to 1000°F (537°C). (2) (3) (4) (5)
9	A217 WC9	2 ¼ CR, 1 Mo	For service up to 1100°F (593°C) where good creep strength is required. (2) (3) (4) (5)
5	A217 C5	5% CR, ½ Mo	For service up to 1200°F (649°C). Best corrosion and oxidation resistance plus high creep strength are required. (2)
12	A217 C12	9% CR, 1 Mo	For service up to 1200°F (649°C). Best corrosion and oxidation resistance than other grades. (2)
2	A352 LCC	Low Carbon Steel	For service from -20°F to 650°F (-33°C to 343°C). This material must be quenched and tempered to obtain tensile and impact properties needed at subzero temperatures.
8M	A351 CF8M	Stainless Steel (316)	For services up to 1000°F (537°C), where corrosion and oxidation resistance are desired.
8	A351 CF8	Stainless Steel (304)	For services up to 1000°F (537°C), where corrosion and oxidation resistance are desired, but lower costs than CF8M and slightly lower material strengths and corrosion resistance can be tolerated.

(1) Upon prolonged exposure to temperatures above 800°F (426°C), the carbide phase of carbon steel may be converted to graphite. Permissible, but not recommended for prolonged usage above 800°F (426°C).

(2) Flanged end valves rated to 1000°F (537°C).

(3) Considerations should be given to the possibility of excessive oxidation (scaling) when used above 1050°F (565°C).

(4) Product used within the jurisdiction of Section 1 Power Boilers of the ASME Boiler and Pressure Vessel code is subject to the same temperature limitations as specified in that document.

(5) Product used within the jurisdiction of Power Piping, ASME Code for Pressure Piping B31.1, is subject to the same maximum temperature limitations placed upon the material in paragraph 124.2.

Trim Material

Part No. Suffix	API Trim Number	Nominal Trim	Seating Surfaces	Stem Material	Temperature
X	1	F6 / F6 (1)	13 Cr ASTM A217 (CA15)	13 Cr (410)	1100°F (593°C)
UF*	5	HF / HF (2)	Stellite® 6	13 Cr (410)	1200°F (649°C)
A	9	Monel® / Monel® (4)	Monel®	Monel®	450°F (232°C)
L	10	316 / 316 (3)	316 SS	316 SS	850°F (454°C)
XUF*	8	F6 / HF (1) (2)	13 Cr ASTM A217 (CA 215) Stellite® 6	13 Cr (410)	1100°F (593°C)
AUF*	11	Monel® / HF (4) (2)	Monel® Stellite® 6	Monel®	450°F (232°C)
LUF*	12	316 / HF (3) (2)	316 SS Stellite® 6	316 SS	850°F (454°C)

(1) 13% Chromium AISI Type 410 Stainless Steel.

(2) Hard Facing is weld deposited Cobalt base alloy.

(3) Austenitic Stainless Steel is a Ni-Cr-Mo stainless steel in the AISI Type 316 category.

(4) Ni-Cu Alloy.

*F denotes Flex Wedge (only applies to Gate Valves).

Valve Modification Suffix Identification

S.I.	Description	S.I.	Description	S.I.	Description	S.I.	Description
TD	Drain, Drill and Tap	ST	Special Trim	SP	Special Paint	OV	(1) Gear (4) Pneumatic
BP	Bypass	BW	Special Butt-Weld End Prep	LD	Locking Device		(2) Chainwheel (5) Hydraulic
PG	Special Packing and/or Gasket	RJ	Ring Joint	LR	Lantern Ring		(3) Electric (6) Other

Performance In Any Application

In any fluid handling system, valves are the controlling element: starting or stopping flow, regulating or throttling flow, preventing backflow, or relieving and regulating pressure.

Since Crane valves are used in a variety of applications, the following descriptions may provide a basic guideline in the selection of steel valves.

Gate Valves

Gate valves serve as efficient stop valves with flow in either direction. They are commonly used where a minimum pressure drop is important. Throttling is not recommended because partially open gate valves exhibit flow characteristics not conducive to accurate and consistent flow control. Also, the valves may be damaged by the high velocity across the seats. They function best fully open or fully closed.

Gear Actuators recommended for Gate valves:

Class 150: sizes above 10"

Class 300: sizes above 8"

Class 600: sizes above 6"

Globe Valves

Globe valves are ideal for throttling service. Their flow characteristics permit accurate and repeatable flow control. However, caution must be exercised to avoid extremely close throttling when pressure drop exceeds 20%. This creates excessive noise, vibration and possible damage to valves and piping. When these conditions are anticipated, consult Crane for recommendations.

Gear Actuators recommended for Globe valves:

Class 150: sizes above 6"

Class 300: sizes above 6"

Class 600: sizes above 4"

Swing Check Valves

Swing Check valves prevent reversal of flow through pipe lines. Most Crane swing check valves can be installed in horizontal or vertical, upward flow, piping. They offer low resistance to flow and are particularly suited to low velocity service.

Tilting Disc Check Valves

Tilting Disc Check valves are similar to swing check valves. In most installations, slamming is minimized upon reversal of flow so noise and vibration are reduced.

Stop Check Valves

Stop check valves are essentially the same as globe and angle valves, except there is no mechanical connection between the stem and disc. However, they are not designed for throttling. They are used in steam boiler outlet piping when two or more boilers are connected to a common header. Valves must be installed with pressure under the disc, and when the stem is raised, only boiler pressure can raise the disc, whenever boiler pressure exceeds header pressure. They prevent steam backflow from the header to the boiler.

Installation, Marking, and Identification

When purchasing valves, reference should also be made to MSS SP92 "Valve Users Guide." Inquiries relating specifically to Crane products may be referred to our factory or customer service department.

Marking and identification of Crane steel valves conforms to ASME B16.34 and MSS SP-25.

It is important to properly identify valves in service to allow for the ordering of replacement parts or address questions or concerns relating to our products. Body markings and information shown on the identification plate helps to properly identify valves, allowing timely and accurate responses to such inquiries.

Integrally cast body marking data includes the following information and helps to provide traceability:

- Crane logo
- Pressure class
- Valve size
- "Steel" symbol for the grade of material (i.e., WCB for carbon steel)
- Heat number – on body and bonnet (cast or stamped)
- Individual serialization

The body markings are supplemented by an identification plate which, depending on valve type and size, is mounted in the most practicable position. Tag location for gate and globe valves is typically on the valve yoke or body/bonnet flange. Check valve tags are typically mounted on the rim of the cap.

Identification plates bear the following information:

- Catalog number
- Valve size
- Body material
- Disc material
- Stem material
- Seat and trim material
- Pressure and temperature rating

I.D. Tag Marking Information

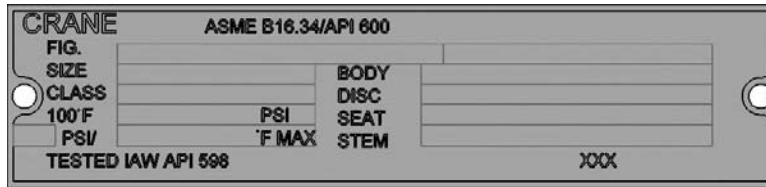

Product Marking

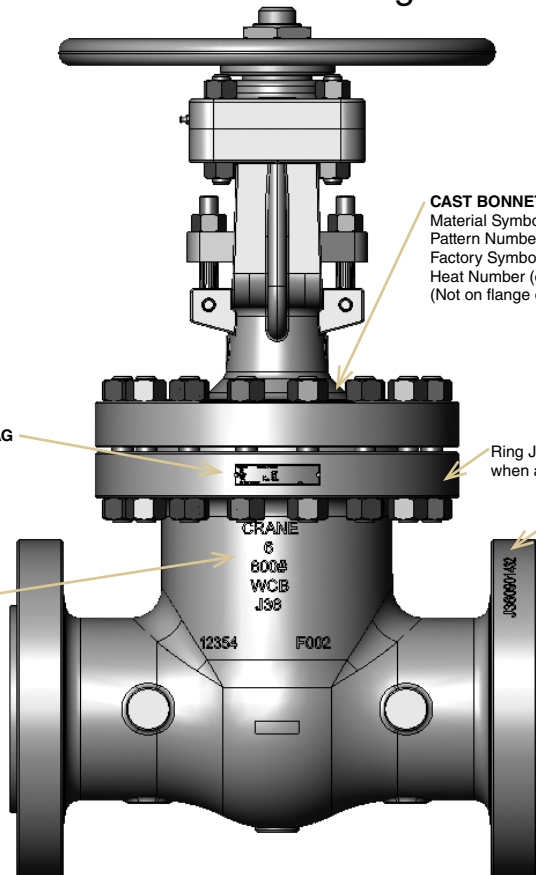

CAST BONNET MARKING:
 Material Symbol
 Pattern Number
 Factory Symbol
 Heat Number (cast or stamped)
 (Not on flange edge unless recessed.)

ID TAG

Ring Joint Number (stamped) when applicable

Serial Number (stamped)

CAST BODY MARKING:
 CRANE
 Size 2, 2½, 3, 4...
 Class 150, 300, 600, 900
 Material Material Grade Symbol
 Factory ID Manufacturer's Identification Symbol
 Pattern No. XXXXX (Optional)
 Foundry Symbol YYYY

NOTES:
 Cast lettering to be raised Gothic type.
 All stamped markings to be low stress.

General Information • Class 150, 300, and 600 Valves

Features

Flexible Wedge

- Compensates for deformation of body due to pipe stresses.
- Will not stick when valve is closed hot and allowed to cool.

Welded-in Seat Ring

- Seat ring is seal welded to eliminate leak path.

Standards

These valves comply with the applicable requirements of the following standards:

- API 600
- API 598
- ASME B16.34
- ASME B16.25
- ASME B16.10
- ASME B16.5

Inspection Policy for Crane Valves

Every Crane cast steel valve is subjected to a 100% pressure test according to API 598 requirements. Manufacturer's material test reports and Inspection and Test Certifications are available upon request. Some of the additional inspections and tests performed are:

- Random Radiograph Inspection of Body and Bonnet Castings to ASME B16.34 Appendix B
- Random Chemical Composition and Mechanical Properties Verification of Fasteners to ASTM A-193/A-194
- Liquid Penetrate Inspection of Seat Rings
- Visual Inspection of Casting to MSS SP-55 and MSS SP-112
- Receiving, In-Process, and Final Dimensional Inspections to Relevant Valve Standards

Other inspections or tests can be performed or evaluation criteria applied when specified by the customer.

Notes

- Standard material is ASTM A216 Grade WCB.
- Standard trim is XU (13% Cr to hardface) which is suitable for a wide range of applications.
- Butt weld end dimensions shall be in accordance with ASME B16.25 Figure 2a or Figure 3a (without backing ring) for standard pipe schedules, unless otherwise specified in the purchase order. Butt weld ends shall not be produced from flanged end castings unless specifically authorized in writing by CRANE Energy Flow Solutions.

Class	Schedule
150/300	Standard
600	Extra Strong
900/1500	Schedule 160

- See "Technical Data" section for locations of bypasses, taps and drains.

Typical Bolted Bonnet Gate Valve Features

Crane gate valves offer the ultimate in dependable service for steam, air, gas, oil, oil vapor, and high pressure installations. All have straight-through ports to assure minimum turbulence, erosion, and resistance to flow. They are available in a wide variety of trims.

1. **Body:** Body is cast to provide liberal strength to meet operating conditions and to permit unobstructed flow. Turbulence, erosion and pressure drop are minimized.
Flanged End-Crane cast steel gate valves are available in flanged end and butt weld ends. All flanged and butt welding end valves are designed to conform to ASME B16.5 and ASME B16.34 standards.
2. **Integral Yoke & Bonnet:** Some designs incorporate a two-piece bonnet and yoke. All bonnet assemblies are cast and finished to the same exacting tolerances as the bodies for accurate alignment of stems and ease of sealing. Bonnet joint varies from flat face gasket-joint to ring-type bonnet joint, depending on class.
3. **Seat Rings:** Seat rings are seal welded to eliminate leak path behind rings and for long trouble-free service. The surfaces are precision ground to fit accurately with the disc.
4. **Disc:** Crane's one piece flexible disc provides accurate alignment of mating seating surfaces so the valve can absorb piping strains without leakage. Also, it avoids any tendency to stick in the seated position.
5. **Stem:** The tee-head disc-stem connection prevents lateral strain on the stem for smooth, easy operation. Accurately cut threads engage the yoke sleeve for positive control of disc position.
6. **Yoke Sleeve**
7. **Handwheel Nut**
8. **Yoke Sleeve Retaining Nut**
9. **Packing:** Packing contains corrosion inhibitor to avoid stem pitting. Stuffing box is deep, assuring long packing life.
10. **Gland:** Gland is a two-piece ball-type which exerts even pressure on the packing without binding the stem.
11. **Gland Flange**
12. **Gland Eye Bolts:** Eyebolts swing aside for ease in repacking the stuffing box.
13. **Gland Eye Bolt Nuts**
14. **Bonnet Gasket**
15. **Bonnet Studs:** Number is dependent on valve size and class.
16. **Bonnet Nuts:** Number is dependent on valve size and class.
17. **Gland Eyebolt Pins**
18. **Bonnet Bushing**
19. **Handwheel:** Crane gate valves can also be supplied with gear or motor operators.
20. **Hydraulic Grease Fitting:** Hydraulic grease fitting provides for lubrication of yoke sleeve bearing surfaces (not shown).

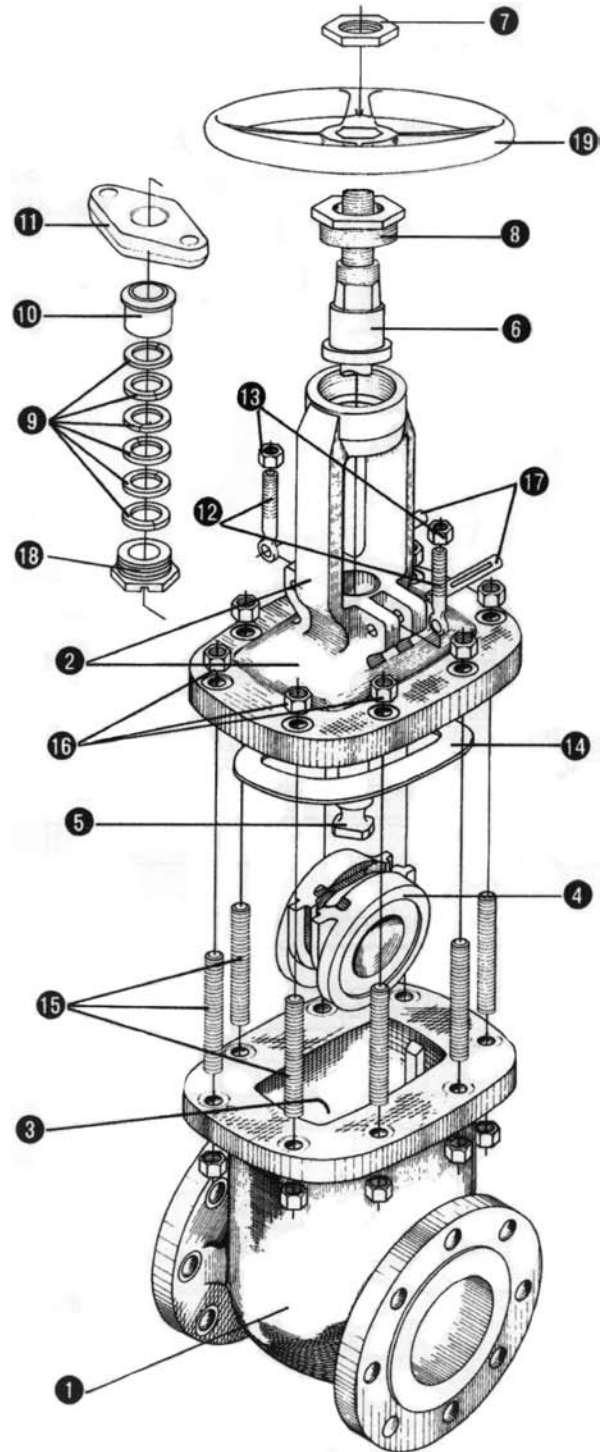

NOTE: Crane recommends the use of gear assistance for certain multi-turn valves for optimal functional performance in larger sizes and high flow-rate applications. Please refer to the note on specific product pages.

Class 150 • Outside Screw & Yoke • Flexible Wedge Disc

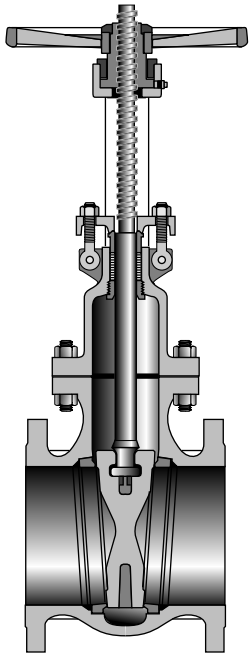
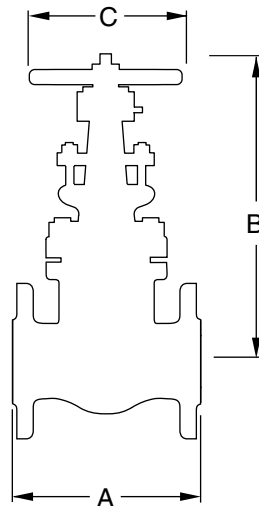

Figure 47
Flanged
Figure 47½
Butt Weld

Size Range:
2 through 24 inches
(50 - 600 mm)

Pressure Temperature Rating
Carbon Steel
ASTM A216 Grade WCB
285 psi @ -20°F to 100°F
(20 bar @ -28°C to 37°C)



Industry Standards

Steel Valves	ASME B16.34
Face-to-Face/End-to-End	ASME B16.10
Flange Dimensions	ASME B16.5
Weld End	ASME B.16.25
Basic Design	API 600
Testing	API 598

Material of Construction*

Description	Material
Body	WCB
Bonnet	WCB
Seat Rings	Hardfaced
Disc	CA-15 or 13% CR Overlay
Stem	410 SS
Packing	Graphite
Bonnet Gasket	Corrugated Soft Steel or Steel/ Stainless Steel w/Graphite
Back Seat	410 SS
Yoke Sleeve	D2 Ni-Resist
Retaining Nut	Malleable or Steel
Gland	Steel
Gland Flange	Steel
Eye Bolt	Steel
Eye Bolt Nuts	Steel
Pins	Steel
Bonnet Studs	A193 Gr. B7
Bonnet Nuts	A194 Gr. 2H
Handwheel	Malleable, Ductile or Steel
Handwheel Nut	Ductile or Steel
I.D. Tags	SS
I.D. Pins	Steel
Spacer	Steel
Grease Fittings	Steel

NOTES:

*Standard construction: WCB-Trim 8, other options are available. Crane recommends the use of manual or powered gear assistance for sizes 10" and larger.

Dimensions and Weights

Inches (millimeters) - pounds (kilograms)

Valves	2 (50)	2½ (65)	3 (80)	4 (100)	6 (150)	8 (200)	10 (250)	12 (300)	14 (350)	16 (400)	18 (450)	20 (500)	24 (600)
A	7.00 (178)	7.50 (191)	8.00 (203)	9.00 (229)	10.50 (267)	11.50 (292)	13.00 (330)	14.00 (356)	15.00 (381)	16.00 (406)	17.00 (432)	18.00 (457)	20.00 (508)
A (47½)	8.50 (216)	9.50 (241)	11.12 (282)	12.00 (305)	15.88 (403)	16.50 (419)	18.00 (457)	19.75 (502)	22.50 (572)	24.00 (610)	26.00 (660)	28.00 (711)	32.00 (813)
B (Open)	17 (432)	17 (432)	19 (483)	23 (584)	31 (787)	39 (990)	47 (1193)	55 (1397)	61 (1549)	71 (1803)	78 (1981)	90 (2286)	99 (2515)
C	8 (203)	8 (203)	9 (229)	10 (254)	12 (305)	14 (356)	16 (406)	18 (457)	22 (559)	24 (610)	25 (635)	27 (686)	30 (762)
Wt. (47)	49 (22)	55 (25)	74 (33)	110 (50)	192 (87)	300 (136)	420 (190)	630 (285)	905 (410)	1260 (571)	1590 (721)	2580 (1170)	3240 (1469)
Wt. (47½)	45 (20)	48 (21)	67 (30)	98 (44)	180 (81)	290 (131)	430 (195)	625 (283)	910 (412)	1260 (571)	1590 (721)	2580 (1170)	3250 (1474)

Class 300 • Outside Screw & Yoke • Flexible Wedge Disc

Material of Construction*

Description	Material
Body	WCB
Bonnet	WCB
Seat Rings	Hardfaced
Disc	CA-15 or 13% CR Overlay
Stem	410 SS
Packing	Graphite
Bonnet Gasket	Stainless Steel spiral wound Graphite
Back Seat	410 SS
Yoke Sleeve	D2 Ni-Resist
Retaining Nut	Malleable or Steel
Gland	Steel
Gland Flange	Steel
Eye Bolt	Steel
Eye Bolt Nuts	Steel
Pins	Steel
Bonnet Studs	A193 Gr. B7
Bonnet Nuts	A194 Gr. 2H
Handwheel	Malleable, Ductile or Steel
Handwheel Nut	Ductile or Steel
I.D. Tags	SS
I.D. Pins	Steel
Spacer	Steel
Grease Fittings	Steel

NOTES:

*Standard construction: WCB-Trim 8, other options are available. Crane recommends the use of manual or powered gear assistance for sizes 8" and larger.

Figure 33

Flanged

Figure 33½

Butt Weld

Size Range:

2 through 24 inches
(50 - 600 mm)

Pressure Temperature Rating

Carbon Steel

ASTM A216 Grade WCB
740 psi @ -20°F to 100°F
(51 bar @ -28°C to 37°C)

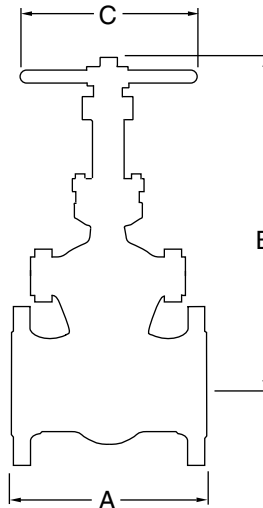
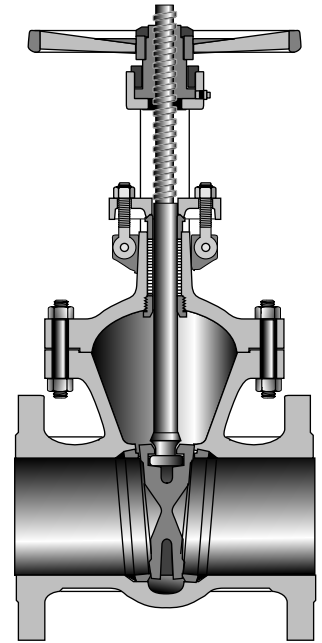

Industry Standards

Steel Valves	ASME B16.34
Face-to-Face/End-to-End	ASME B16.10
Flange Dimensions	ASME B16.5
Weld End	ASME B.16.25
Basic Design	API 600
Testing	API 598

Dimensions and Weights

Inches (millimeters) - pounds (kilograms)

Valves	2 (50)	2 ½ (65)	3 (80)	4 (100)	6 (150)	8 (200)	10 (250)	12 (300)	14 (350)	16 (400)	18 (450)	20 (500)	24 (600)
A	8.50 (216)	9.50 (241)	11.12 (282)	12.00 (305)	15.88 (403)	16.50 (419)	18.00 (457)	19.75 (502)	30.00 (762)	33.00 (838)	36.00 (914)	39.00 (990)	45.00 (1143)
B (Open)	18 (457)	18 (457)	21 (533)	24 (609)	33 (838)	42 (1066)	50 (1270)	58 (1473)	62 (1574)	71 (1803)	79 (2006)	85 (2154)	100 (2540)
C	8 (203)	8 (203)	9 (229)	10 (254)	14 (356)	16 (406)	18 (457)	20 (508)	22 (559)	24 (610)	25 (635)	30 (762)	30 (762)
Wt. (33)	69 (31)	77 (34)	112 (50)	165 (74)	310 (140)	500 (226)	760 (344)	1050 (476)	1530 (693)	2380 (1079)	2722 (1234)	3650 (1655)	5115 (2320)
Wt. (33½)	57 (25)	64 (29)	92 (41)	132 (59)	256 (116)	410 (185)	650 (294)	880 (399)	1530 (693)	2380 (1079)	2000 (907)	3370 (1528)	4675 (2120)

Class 600 • Outside Screw & Yoke • Flexible Wedge Disc

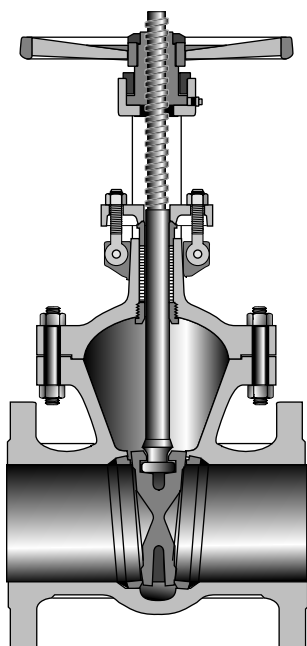
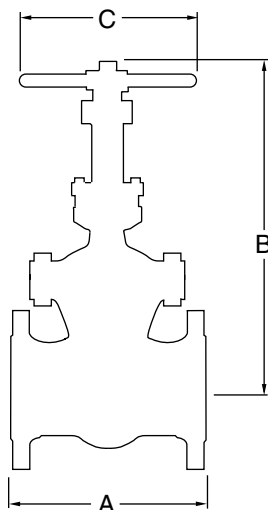

Figure 76
Flanged
Figure 76½
Butt Weld

Size Range:
2 through 12 inches
(50 - 300 mm)

Pressure Temperature Rating
Carbon Steel
ASTM A216 Grade WCB
1480 psi @ -20°F to 100°F
(102 bar @ -28°C to 37°C)



Industry Standards

Steel Valves	ASME B16.34
Face-to-Face/End-to-End	ASME B16.10
Flange Dimensions	ASME B16.5
Weld End	ASME B.16.25
Basic Design	API 600
Testing	API 598

Material of Construction*

Description	Material
Body	WCB
Bonnet	WCB
Seat Rings	Hardfaced
Disc	CA-15 or 13% CR Overlay
Stem	410 SS
Packing	Graphite
Bonnet Gasket	Ring Type Joint
Back Seat	410 SS
Yoke Sleeve	D2 Ni-Resist
Retaining Nut	Malleable or Steel
Gland	Steel
Gland Flange	Steel
Eye Bolt	Steel
Eye Bolt Nuts	Steel
Pins	Steel
Bonnet Studs	A193 Gr. B7
Bonnet Nuts	A194 Gr. 2H
Handwheel	Malleable, Ductile or Steel
Handwheel Nut	Ductile or Steel
I.D. Tags	SS
I.D. Pins	Steel
Spacer	Steel
Grease Fittings	Steel

NOTES:

*Standard construction: WCB-Trim 8, other options are available. Crane recommends the use of manual or powered gear assistance for sizes 6" and larger.

Dimensions and Weights

Inches (millimeters) - pounds (kilograms)

Valves	2 (50)	2½ (65)	3 (80)	4 (100)	6 (150)	8 (200)	10 (250)	12 (300)
A	11.50 (292)	13.00 (330)	14.00 (355)	17.00 (431)	22.00 (558)	26.00 (660)	31.00 (787)	33.00 (838)
B (Open)	17 (431)	19 (482)	23 (584)	27 (685)	36 (914)	42 (1066)	51 (1295)	58 (1473)
C	10 (254)	10 (254)	12 (304)	14 (355)	18 (457)	20 (508)	25 (635)	27 (685)
Wt. (76)	99 (44)	121 (54)	170 (77)	280 (127)	590 (267)	1080 (489)	1660 (752)	2070 (938)
Wt. (76½)	85 (38)	110 (49)	167 (75)	280 (127)	610 (276)	1070 (485)	1670 (757)	2070 (938)

NACE Trim Steel Valves

For servicing sour environments of Hydrogen Sulfide (H₂S) bearing hydrocarbons, Crane offers NACE valves made of component materials specially heat-treated and hardness-controlled in compliance with NACE standard MR0103. Typical NACE material configurations are shown below for Crane cast steel gate valves.

- A** Body & Bonnet – Most NACE requirements for heat treatment and maximum hardness of 22 HRC. Standard material is ASTM A216 Grade WCB.
- B** Bolting – ASTM A193 Grade B7M bolts and ASTM A194 Grade 2HM nuts meet both NACE Classes I and II.
- C** Stem – Offering superior resistance to stress corrosion cracking, standard NACE stem is type 316 stainless steel in conformance with NACE hardness and heat treatment requirements.
- D** Disc – Standard disc is one piece flexible wedge ASTM A351 Grade CF8M, type 316 stainless steel in conformance with NACE hardness and heat treatment requirements.

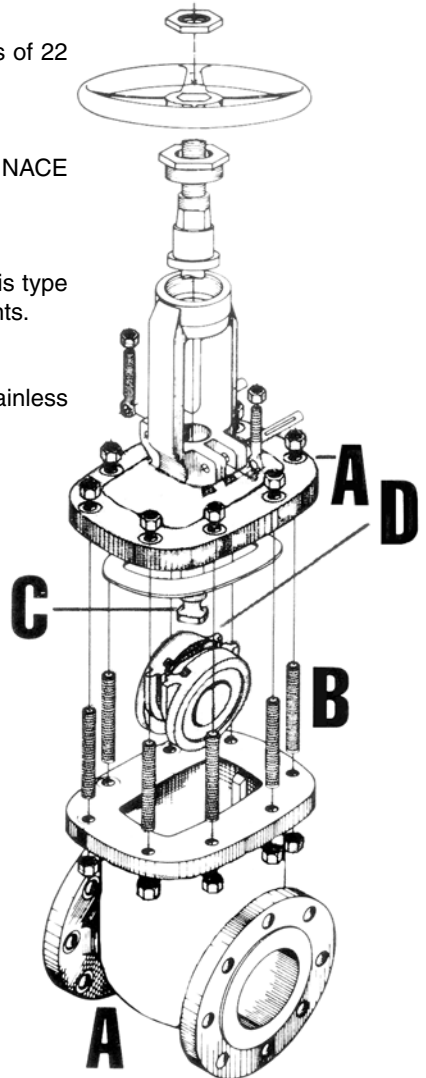

NACE Valves Compared to API 600 Valves			
Valve Parts	API and Hardness	LF Trim NACE	LUF Trim NACE
Body/Bonnet	ASTM A216 Grade WCB	ASTM A216 Grade WCB; ≤22HRC	ASTM A216 Grade WCB; ≤22HRC
Disc – Solid Metal	ASTM A217 Grade CA15; 250 min.	ASTM A351 Grade CF8M; ≤22HRC	ASTM A351 Grade CF8M; ≤22HRC
Seat Ring	Stellite® Overlaid; Overlay ≥350 HB	316L Overlaid; Base Metal ≤22 HRC	Stellite® Overlaid; Base Metal ≤22 HRC
Gland	Steel Zinc Plated	Steel Zinc Plated; Base Metal ≤22 HRC	Steel Zinc Plated; Base Metal ≤22 HRC
Stem	13Cr; 200-275 HB	ASTM A182 Grade F316; ≤22HRC	ASTM A182 Grade F316; ≤22HRC
Backseat Bushing	13Cr; 250 HB min.	ASTM 479 Grade T316; ≤22 HRC	ASTM 479 Grade T316; ≤22HRC
Body/Bonnet Studs	ASTM A193 Grade 2H	ASTM A193 Grade B7M	ASTM A193 Grade B7M
Body/Bonnet Nuts	ASTM A194 Grade 2H	ASTM A194 Grade 2HM	ASTM A194 Grade 2HM

General Information • Class 150, 300, and 600 Valves

Features

Welded-in Seat Ring

- Seat ring is seal welded to eliminate leak path.

Basic Standards

These valves comply with the applicable requirements of the following standards:

- API 598
- ASME B16.34
- ASME B16.25
- ASME B16.10
- ASME B16.5

Notes

- Standard material is ASTM A216 Grade WCB.
- Standard trim is XU (13% Cr to hardface) which is suitable for a wide range of applications.
- Butt weld end dimensions shall be in accordance with ASME B16.25 Figure 2a or Figure 3a (without backing ring) for standard pipe schedules, unless otherwise specified in the purchase order. Butt weld ends shall not be produced from flanged end castings unless specifically authorized in writing by CRANE Energy Flow Solutions.

Class	Schedule
150/300	Standard
600	Extra Strong
900/1500	Schedule 160

- See "Technical Data" section for locations of bypasses, taps and drains.

Typical Globe Valve Features

Crane globe valves are highly efficient for services requiring frequent operation and throttling when pressure drop across the valve is about 20% of inlet pressure. Closer throttling, creating higher pressure drops may cause cavitation or excessive velocities which could cause high noise levels, vibration and possible damage to the valve or adjacent piping. Globe valves can be equipped with optional operators and are available with a variety of trims to match service requirements.

1. **Body:** Body is cast with heavy sections reinforced at points subjected to the greatest stress. Valves are available in both flanged and butt welding ends. All conform to ASME specifications.
2. **Bonnet**
3. **Seat Ring**
4. **Disc**
5. **Disc Stem Nut:** Disc Stem Ring connects the disc to the stem, permitting the disc to swivel and aid in securing tight seating for trouble-free service.
6. **Disc Washer**
7. **Stem:** Stem has long engagement with yoke bushing for accurate seating.
8. **Bonnet Bushing**
9. **Yoke Bushing**
10. **Wheel Nut**
11. **Packing**
12. **Gland:** Gland is a two-piece, ball-type which exerts even pressure on the packing without binding the stem.
13. **Gland Flange**
14. **Gland Eye Bolts:** Eye bolts are securely fastened to the bonnet yet swing away to permit easy access to the stuffing box.
15. **Bonnet Gasket:** Bonnet gasket provides a positive seal against leakage. Class 150 and 300 valves have a male/female bonnet joint. A ring-type gasket is employed in Class 600.
16. **Bonnet Studs**
17. **Bonnet Nuts**
18. **Pin**
19. **Handwheel**

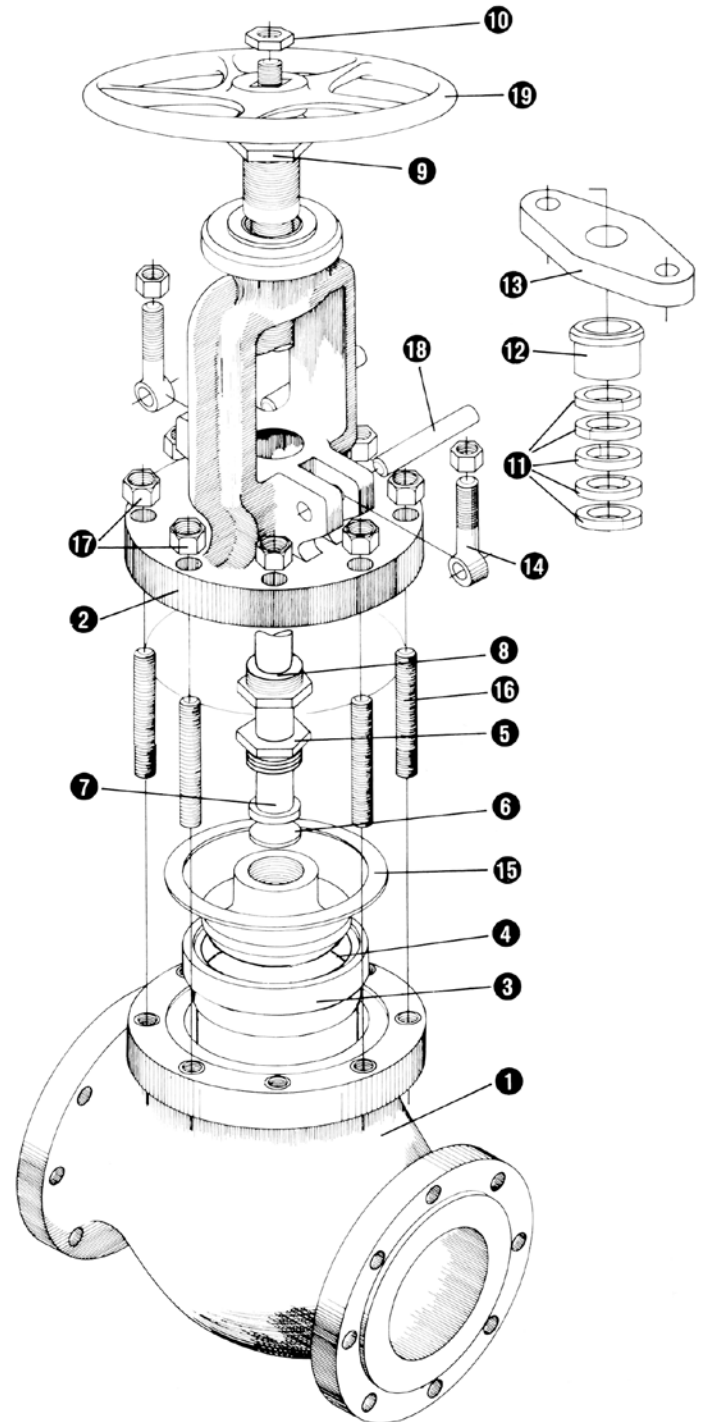

NOTE: Crane recommends the use of gear assistance for certain multi-turn valves for optimal functional performance in larger sizes and high flow-rate applications. Please refer to the note on specific product pages.

Class 150 • Outside Screw & Yoke • Bolted Bonnet

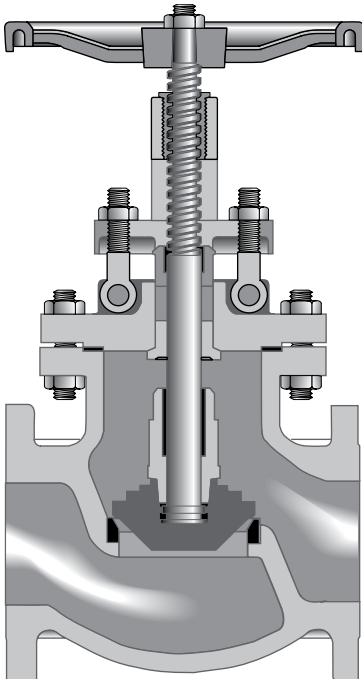

Figure 143

Flanged

Figure 143½

Butt Weld

Size Range:

2 through 12 inches
(50 - 300 mm)

Pressure Temperature Rating

Carbon Steel
ASTM A216 Grade WCB
285 psi @ -20°F to 100°F
(20 bar @ -28°C to 37°C)

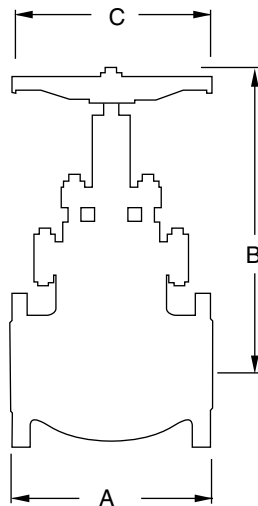

Industry Standards

Steel Valves	ASME B16.34
Face-to-Face/End-to-End	ASME B16.10
Flange Dimensions	ASME B16.5
Weld End	ASME B.16.25
Testing	API 598

Material of Construction*

Description	Material
Body	WCB
Bonnet	WCB
Seat Rings	Hardfaced
Disc	13% CR Overlay
Stem	410 SS
Packing	Graphite
Bonnet Gasket	Corrugated Soft Steel or Steel/ Stainless Steel w/Graphite
Back Seat	410 SS
Disc Stem Nut	410 SS
Disc Washer	Carbon Steel
Gland	410 SS
Gland Flange	WCB
Eye Bolt	Steel
Eye Bolt Nuts	A563 Gr. A or O
Pins	-
Bonnet Studs	A193 Gr. B7
Bonnet Nuts	A194 Gr. 2H
Handwheel	WCB
Handwheel Nut	A194 Gr. 2H
I.D. Tags	SS
I.D. Pins	Steel

NOTES:

*Standard construction: WCB-Trim 8, other options are available. Crane recommends the use of manual or powered gear assistance for sizes 6" and larger.

Dimensions and Weights

Inches (millimeters) - pounds (kilograms)

Valves	2 (50)	2 ½ (65)	3 (80)	4 (100)	6 (150)	8 (200)	10 (250)	12 (300)
A	8.00 (203)	8.50 (216)	9.50 (241)	11.50 (292)	16.00 (406)	19.50 (495)	24.50 (622)	27.50 (698)
B (Open)	14 (356)	16 (406)	16 (406)	19 (482)	21 (533)	24 (610)	29 (736)	40 (1016)
C	8 (203)	8 (203)	10 (254)	12 (304)	14 (355)	18 (457)	20 (508)	24 (610)
Wt. (143)	48 (21)	70 (31)	92 (41)	132 (59)	223 (101)	355 (161)	640 (290)	1100 (498)
Wt. (143½)	49 (22)	60 (27)	84 (38)	137 (62)	230 (104)	350 (158)	680 (308)	1190 (539)

Class 300 • Outside Screw & Yoke • Bolted Bonnet

Material of Construction*

Description	Material
Body	WCB
Bonnet	WCB
Seat Rings	Hardfaced
Disc	13% CR Overlay
Stem	410 SS
Packing	Graphite
Bonnet Gasket	Stainless Steel spiral wound Graphite
Back Seat	410 SS
Disc Stem Nut	410 SS
Disc Washer	Carbon Steel
Gland	410 SS
Gland Flange	WCB
Eye Bolt	Steel
Eye Bolt Nuts	A563 Gr. A or O
Pins	-
Bonnet Studs	A193 Gr. B7
Bonnet Nuts	A194 Gr. 2H
Handwheel	WCB
Handwheel Nut	A194 Gr. 2H
I.D. Tags	SS
I.D. Pins	Steel

NOTES:
 *Standard construction: WCB-Trim 8, other options are available.
 Crane recommends the use of manual or powered gear assistance for sizes 6" and larger.

Figure 151
Flanged

Figure 151½
Butt Weld

Size Range:
 2 through 12 inches
 (50 - 300 mm)

Pressure Temperature Rating
 Carbon Steel
 ASTM A216 Grade WCB
 740 psi @ -20°F to 100°F
 (51 bar @ -28°C to 37°C)

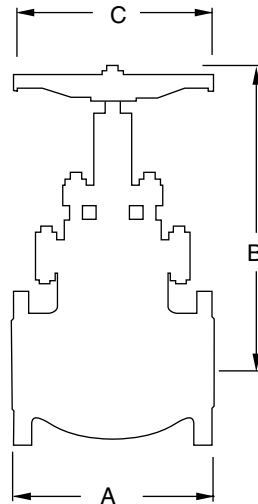
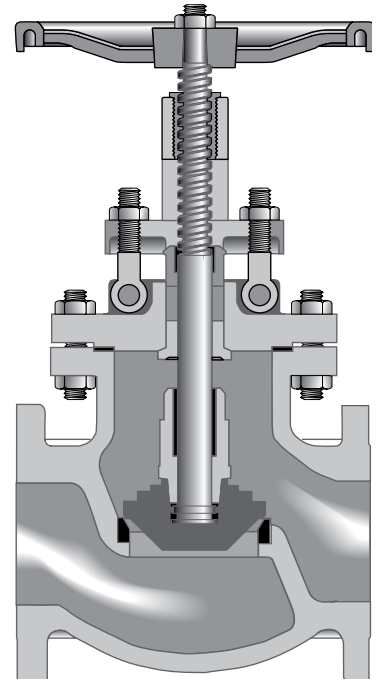

Industry Standards

Steel Valves	ASME B16.34
Face-to-Face/End-to-End	ASME B16.10
Flange Dimensions	ASME B16.5
Weld End	ASME B.16.25
Testing	API 598

Dimensions and Weights

Inches (millimeters) - pounds (kilograms)

Valves	2 (50)	2½ (65)	3 (80)	4 (100)	6 (150)	8 (200)	10 (250)	12 (300)
A	10.50 (267)	11.50 (292)	12.50 (317)	14.00 (356)	17.50 (444)	22.00 (558)	24.50 (622)	28.00 (711)
B (Open)	15 (381)	18 (457)	18 (457)	21 (533)	25 (635)	36 (914)	41 (1041)	51 (1295)
C	8 (203)	10 (254)	10 (254)	14 (355)	18 (457)	22 (559)	24 (610)	25 (635)
Wt. (151)	69 (31)	99 (44)	128 (58)	190 (86)	330 (149)	330 (149)	700 (317)	1360 (616)
Wt. (151½)	62 (28)	73 (33)	124 (56)	181 (82)	340 (154)	530 (240)	710 (322)	1400 (635)

Class 600 • Outside Screw & Yoke • Bolted Bonnet

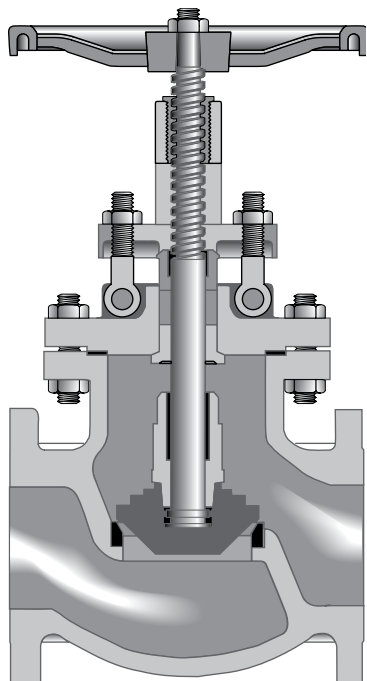
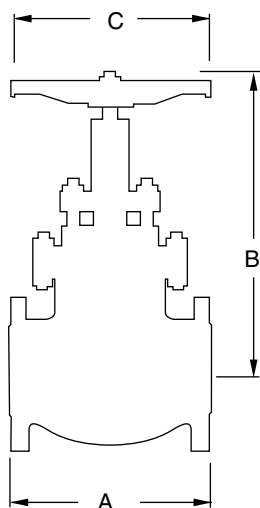

Figure 171
Flanged
Figure 171½
Butt Weld

Size Range:
2 through 8 inches
(50 - 200 mm)

Pressure Temperature Rating
Carbon Steel
ASTM A216 Grade WCB
1480 psi @ -20°F to 100°F
(102 bar @ -28°C to 37°C)



Industry Standards

Steel Valves	ASME B16.34
Face-to-Face/End-to-End	ASME B16.10
Flange Dimensions	ASME B16.5
Weld End	ASME B.16.25
Testing	API 598

Material of Construction*

Description	Material
Body	WCB
Bonnet	WCB
Seat Rings	Hardfaced
Disc	13% CR Overlay
Stem	410 SS
Packing	Graphite
Bonnet Gasket	Ring Type Joint
Back Seat	410 SS
Disc Stem Nut	410 SS
Disc Washer	Carbon Steel
Gland	410 SS
Gland Flange	WCB
Eye Bolt	Steel
Eye Bolt Nuts	A563 Gr. A or O
Pins	-
Bonnet Studs	A193 Gr. B7
Bonnet Nuts	A194 Gr. 2H
Handwheel	WCB
Handwheel Nut	A194 Gr. 2H
I.D. Tags	SS
I.D. Pins	Steel

NOTES:

*Standard construction: WCB-Trim 8, other options are available. Crane recommends the use of manual or powered gear assistance for sizes 4" and larger.

Dimensions and Weights

Inches (millimeters) - pounds (kilograms)

Valves	2 (50)	2½ (65)	3 (80)	4 (100)	6 (150)	8 (200)
A	11.50 (292)	13.00 (330)	14.00 (356)	17.00 (431)	22.00 (558)	26.00 (660)
B (Open)	19 (482)	21 (533)	23 (584)	27 (685)	33 (838)	36 (914)
C	10 (254)	10 (254)	14 (355)	18 (457)	20 (508)	26 (660)
Wt. (171)	126 (57)	154 (69)	188 (85)	270 (122)	890 (403)	990 (449)
Wt. (171½)	79 (35)	100 (45)	187 (84)	271 (122)	890 (403)	990 (449)

General Information • Class 150, 300, and 600 Valves

Features

Disc Type

- For class 600 valves, a ring joint bonnet gasket assures positive seal against leakage and accurate alignment of moving parts

Welded-in Seat Ring

- Seat ring is seal welded to eliminate leak path.

Basic Standards

These valves comply with the applicable requirements of the following standards:

- API 598
- ASME B16.34
- ASME B16.25
- ASME B16.10
- ASME B16.5

Notes

- Standard material is ASTM A216 Grade WCB.
- Standard trim is XU (13% Cr to hardface) which is suitable for a wide range of applications.
- Butt weld end dimensions shall be in accordance with ASME B16.25 Figure 2a or Figure 3a (without backing ring) for standard pipe schedules, unless otherwise specified in the purchase order. Butt weld ends shall not be produced from flanged end castings unless specifically authorized in writing by CRANE Energy Flow Solutions.

Class	Schedule
150/300	Standard
600	Extra Strong
900/1500	Schedule 160

- See "Technical Data" section for locations of bypasses, taps and drains.

Typical Swing Check Valve Features

Check valves are automatically actuated. They are opened and sustained in the open position by the force of velocity pressure, and closed by the force of gravity. Seating load and resultant tightness is dependent upon back pressure. The disc and associated moving parts may be in a constant state of movement if the velocity pressure is not sufficient to hold the valve in a wide open and stable position. Premature wear and noisy operation or vibration of the moving parts can be avoided by selecting the size of check valve on the basis of flow conditions. The minimum velocity required to hold a swing check valve in the wide open and stable position has been developed by analysis of extensive test data and is expressed by the formula:

$$v = 60\sqrt{\bar{v}}$$

The value for v is equal to flow in feet per second and \bar{v} is the specific volume of fluid in cubic feet per pound. Sizing swing check valves on this basis may often result in the use of valves that are smaller than the pipe in which they are used, necessitating the use of reducers for installation. The pressure drop will be no greater than that of the larger valve that is only partially open, and valve life will be greatly extended. The added bonus, of course, is the lower cost of the smaller valve.

There is no tendency for the seating surfaces of swing check valves to gall or score, because the disc meets the flat seat squarely without rubbing contact upon closing.

Crane cast steel swing check valves can be furnished with outside lever and adjustable weight in certain sizes when so ordered. With the lever and weight mounted so that the weight assists the disc in closing, the valve closes more rapidly when flow stops, thus minimizing reversal of flow and resultant surge and shock. With the lever and weight mounted to balance the weight of the disc, the valve becomes more sensitive to low flow velocities. For more information about the size range for which this modification is available, please consult your local sales representative or customer service office.

Swing check valves are used to prevent reversal of flow in horizontal pipe lines. Crane does not recommend the use of swing check valves in vertical pipelines, however when using this style of valve in a vertical application the valve must be installed for upward flow only.

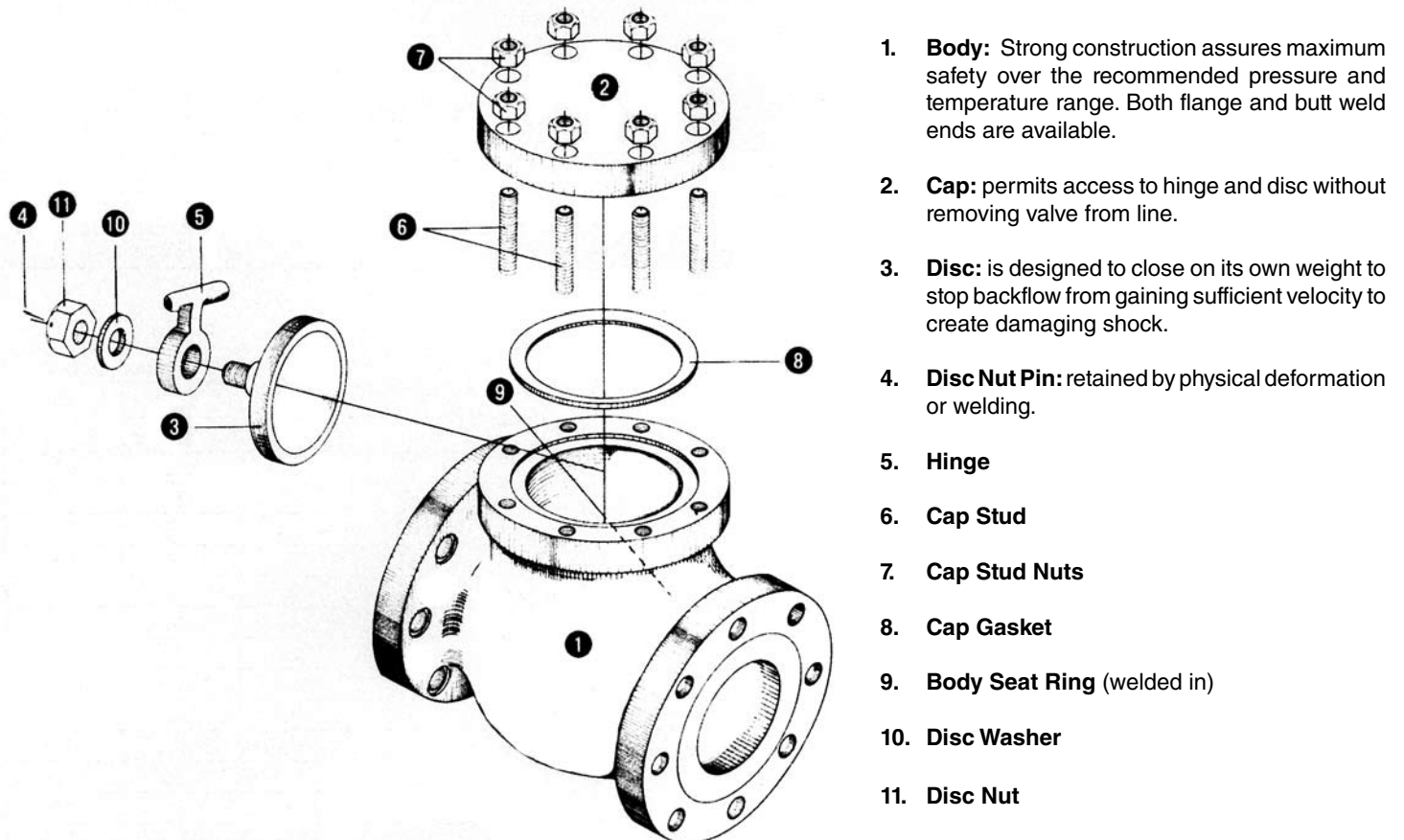

1. **Body:** Strong construction assures maximum safety over the recommended pressure and temperature range. Both flange and butt weld ends are available.
2. **Cap:** permits access to hinge and disc without removing valve from line.
3. **Disc:** is designed to close on its own weight to stop backflow from gaining sufficient velocity to create damaging shock.
4. **Disc Nut Pin:** retained by physical deformation or welding.
5. **Hinge**
6. **Cap Stud**
7. **Cap Stud Nuts**
8. **Cap Gasket**
9. **Body Seat Ring** (welded in)
10. **Disc Washer**
11. **Disc Nut**

NOTE: The above sketch is generic. Valve supplied may be internal hung or external hung type units depending upon pressure class and size.

Cast Steel Swing Check Valve

Figures 147
147½

CRANE®

Class 150 • Bolted Cap

Material of Construction*

Description	Material
Body	WCB
Cap	WCB
Seat Ring	Hardfaced
Disc	13% CR Overlay
Hinge	WCB
Pins, Hinge	410 SS
Disc Washer	Steel
Cap Screw	A307 Gr. B
Cap Gasket	Corrugated Soft Steel or Steel/ Stainless Steel w/Graphite
Cap Studs	A193 Gr. B7
Cap Nuts	A194 Gr. 2H
I.D. Tags	SS
I.D. Pins	Steel

Figure 147

Flanged

Figure 147½

Butt Weld

Size Range:

2 through 24 inches
(50 - 600 mm)

Pressure Temperature Rating

Carbon Steel

ASTM A216 Grade WCB
285 psi @ -20°F to 100°F
(20 bar @ -28°C to 37°C)

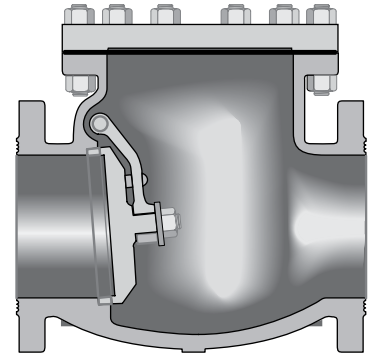

NOTE:

*Standard construction: WCB-Trim 8, other options are available.

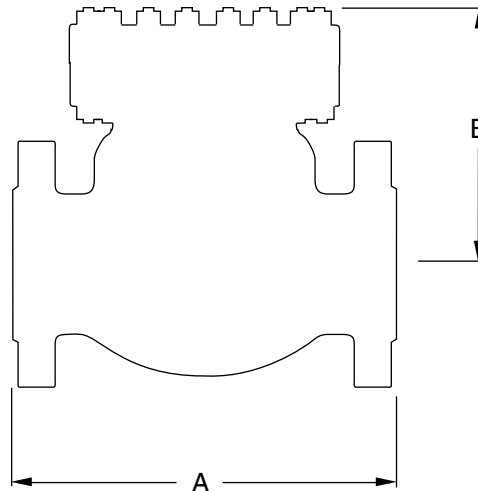

Industry Standards

Steel Valves	ASME B16.34
Face-to-Face/End-to-End	ASME B16.10
Flange Dimensions	ASME B16.5
Weld End	ASME B.16.25
Testing	API 598

Dimensions and Weights

Inches (millimeters) - pounds (kilograms)

Valves	2 (50)	2 ½ (65)	3 (80)	4 (100)	6 (150)	8 (200)	10 (250)	12 (300)	14 (350)	16 (400)	18 (450)	20 (500)	24 (600)
A	8.00 (203)	8.50 (216)	9.50 (241)	11.50 (292)	14.00 (356)	19.50 (495)	24.50 (622)	27.50 (698)	31.00 (787)	34.00 (863)	38.50 (977)	38.50 (977)	51.00 (1295)
B (Open)	9 (229)	7 (178)	7 (178)	9 (229)	11 (279)	13 (330)	15 (381)	17 (432)	15 (381)	17 (432)	18 (457)	19 (482)	22 (558)
Wt.	41 (147)	57 (25)	64 (29)	101 (45)	170 (77)	360 (163)	485 (219)	765 (346)	950 (430)	1225 (555)	1700 (771)	1850 (839)	2600 (1179)
Wt. (147½)	42 (19)	57 (25)	64 (29)	101 (45)	170 (77)	360 (163)	485 (219)	807 (366)	950 (430)	1225 (555)	1700 (771)	1850 (839)	2600 (1179)

Class 300 • Bolted Cap

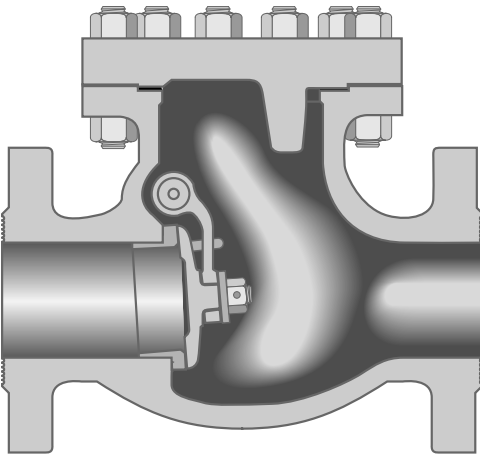

Figure 159
Flanged
Figure 159½
Butt Weld

Size Range:
2 through 24 inches
(50 - 600 mm)

Pressure Temperature Rating
Carbon Steel
ASTM A216 Grade WCB
740 psi @ -20°F to 100°F
(51 bar @ -28°C to 37°C)

Material of Construction*

Description	Material
Body	WCB
Cap	WCB
Seat Ring	Hardfaced
Disc	13% CR Overlay
Hinge	WCB
Pins, Hinge	410 SS
Disc Washer	Steel
Cap Screw	A307 Gr. B
Cap Gasket	Stainless Steel spiral wound Graphite
Cap Studs	A193 Gr. B7
Cap Nuts	A194 Gr. 2H
I.D. Tags	SS
I.D. Pins	Steel

NOTE:
*Standard construction: WCB-Trim 8, other options are available.

Industry Standards

Steel Valves	ASME B16.34
Face-to-Face/End-to-End	ASME B16.10
Flange Dimensions	ASME B16.5
Weld End	ASME B.16.25
Testing	API 598

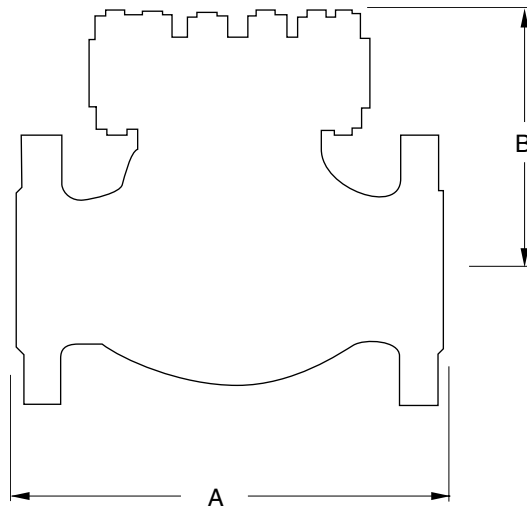

Dimensions and Weights

Inches (millimeters) - pounds (kilograms)

Valves	2 (50)	2 ½ (65)	3 (80)	4 (100)	6 (150)	8 (200)	10 (250)	12 (300)	14 (350)	16 (400)	18 (450)	20 (500)	24 (600)
A	10.50 (266)	11.50 (292)	12.50 (317)	14.00 (356)	17.50 (444)	21.00 (533)	24.50 (622)	28.00 (711)	33.00 (838)	34.00 (863)	38.50 (977)	40.00 (1016)	53.00 (1346)
B (Open)	7 (178)	8 (203)	8 (203)	9 (229)	11 (279)	14 (355)	16 (406)	19 (482)	19 (482)	22 (558)	23 (584)	25 (635)	30 (762)
Wt.	46 (159)	66 (20)	86 (29)	154 (69)	276 (125)	460 (208)	675 (306)	860 (390)	1500 (680)	1850 (839)	2250 (1020)	2900 (1315)	4350 (1973)
Wt. (159½)	33 (14)	49 (22)	86 (39)	97 (43)	276 (125)	460 (208)	677 (307)	992 (449)	1500 (680)	1850 (839)	2250 (1020)	2900 (1315)	4350 (1973)

Cast Steel Swing Check Valve

Figures 175
175½

CRANE

Class 600 • Bolted Cap

Material of Construction*

Description	Material
Body	WCB
Cap	WCB
Seat Ring	Hardfaced
Disc	13% CR Overlay
Hinge	WCB
Pins, Hinge	410 SS
Disc Washer	Steel
Cap Screw	A307 Gr. B
Cap Gasket	Ring Type Joint
Cap Studs	A193 Gr. B7
Cap Nuts	A194 Gr. 2H
I.D. Tags	SS
I.D. Pins	Steel

Figure 175

Flanged

Figure 175½

Butt Weld

Size Range:

2 through 12 inches
(50 - 300 mm)

Pressure Temperature Rating

Carbon Steel
ASTM A216 Grade WCB
1480 psi @ -20°F to 100°F
(102 bar @ -28°C to 37°C)

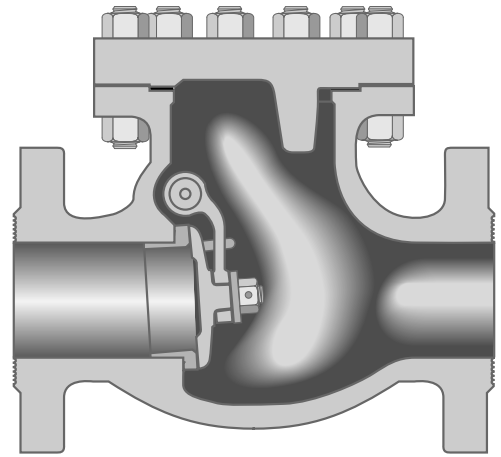

NOTE:

*Standard construction: WCB-Trim 8, other options are available.

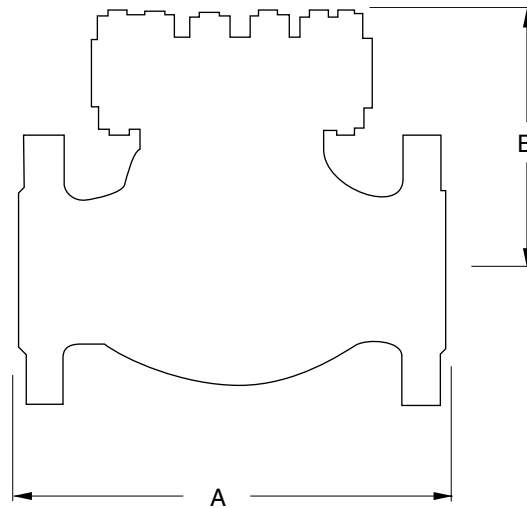

Industry Standards

Steel Valves	ASME B16.34
Face-to-Face/End-to-End	ASME B16.10
Flange Dimensions	ASME B16.5
Weld End	ASME B.16.25
Testing	API 598

Dimensions and Weights

Inches (millimeters) - pounds (kilograms)

Valves	2 (50)	2 ½ (65)	3 (80)	4 (100)	6 (150)	8 (200)	10 (250)	12 (300)
A	11.50 (292)	13.00 (330)	14.00 (356)	17.00 (431)	22.00 (558)	26.00 (660)	31.00 (787)	33.00 (838)
B (Open)	7 (178)	8 (203)	9 (229)	11 (279)	13 (330)	16 (406)	19 (482)	21 (533)
Wt. (175)	115 (52)	145 (65)	161 (73)	284 (128)	500 (226)	1025 (464)	1400 (635)	1950 (884)
Wt. (175½)	100 (45)	125 (56)	154 (69)	250 (113)	450 (204)	850 (385)	1300 (589)	1800 (816)

General Information • Class 150, 300, and 600 Valves

Features

- Reduced maintenance is assured because the disc is the only moving part and is designed to minimize flutter in the closed position, thus reducing wear on the pivot pin, disc, and seat.
- Loss of head is minimized by the balanced disc and its “aerofoil” design. Streamlined body without pockets contributes to straight-through flow.
- Short distance of travel, combined with a balanced disc allows rapid closure while minimizing slamming.
- Drop tight seating is accomplished over the full pressure range because a slight clearance at the pivot pin assures complete seating between the disc ring and body ring.
- Pivot pins are constructed of stainless steel.

Standards

These valves comply with the applicable requirements of the following standards:

- ASME B16.34
- ASME B16.10
- ASME B16.5

Notes

- Valves under 4" (100 mm) are typically supplied with “X” trim.
- Valves 4" (100 mm) and larger are supplied with “XU” trim.
- Butt weld end dimensions shall be in accordance with ASME B16.25 Figure 2a or Figure 3a (without backing ring) for standard pipe schedules, unless otherwise specified in the purchase order. Butt weld ends shall not be produced from flanged end castings unless specifically authorized in writing by CRANE Energy Flow Solutions.

Class	Schedule
150/300	Standard
600	Extra Strong
900/1500	Schedule 160

Typical Tilting Disc Check Valve

Tilting Disc Check Valves consist of a cylindrical housing, with a pivoted circular disc. The pivots are located just above the center of the disc, and offset from the plane of the body seat. This design gives a bell-crank action to the disc. The seat is of circular bevel type and the disc drops in or out of contact without rubbing or sliding.

Features

Slamming of check valves is the result of failure of the valve disc to reach its closed position before the fluid flow reversal. Tilting disc check valves have to close rapidly since the disc has a shorter distance to travel and therefore arrives at the seat faster...minimizing a slam.

Tilting disc check valves are used to prevent reversal of flow in horizontal or vertical pipe lines. In vertical lines, or for any angle from horizontal to vertical, they can be used for upward flow only.

Tilting check valves are automatically actuated. They are opened by velocity pressure, and closed by gravity. Seating load and tightness is dependent on back pressure. The disc and moving parts may constantly move if the velocity pressure is not sufficient to hold the valve in a wide open and stable position. Premature wear and noisy operation or vibration of the moving parts can be avoided by selecting the size of check valve on the basis of flow conditions. The minimum velocity required to hold a tilting disc check valve wide open and stable can be determined by the formula:

$$v = 80\sqrt{\bar{v}}$$

The value for v is equal to flow in feet per second and where \bar{v} is the specific volume of the fluid in cubic feet per pound. Sizing check valves on this basis may often result in the use of valves that are smaller than the pipe in which they are used, necessitating the use of reducers for installation. The pressure drop will not be greater than that of the larger valve that is only partially open, and valve life will be greatly extended. The added bonus, of course, is the lower cost of the smaller valve.

Standard body design configurations

The seat, disc and pivot pins are combined into one subassembly secured to the inlet side of the body with a locking ring in sizes 3" (80 mm) and smaller. This construction avoids the need for extending the pivot pins through the valve body.

The seat formed on the end of the inlet body section by cobalt base alloy hard facing deposit in sizes 4" (100 mm) and larger. The pivot pins supporting the disc are inserted through capped and gasketed bearing bosses in the outlet section of the body.

1. Body Inlet Half
2. Body Outlet Half
3. Disc
4. Pivot Pin
5. Body Gasket
6. Body Studs
7. Body Stud Nuts
8. Bearing Cap Gasket
9. Bearing Cap
10. Bearing Cap Studs
11. Bearing Cap Stud Nuts
12. Dowel Pins

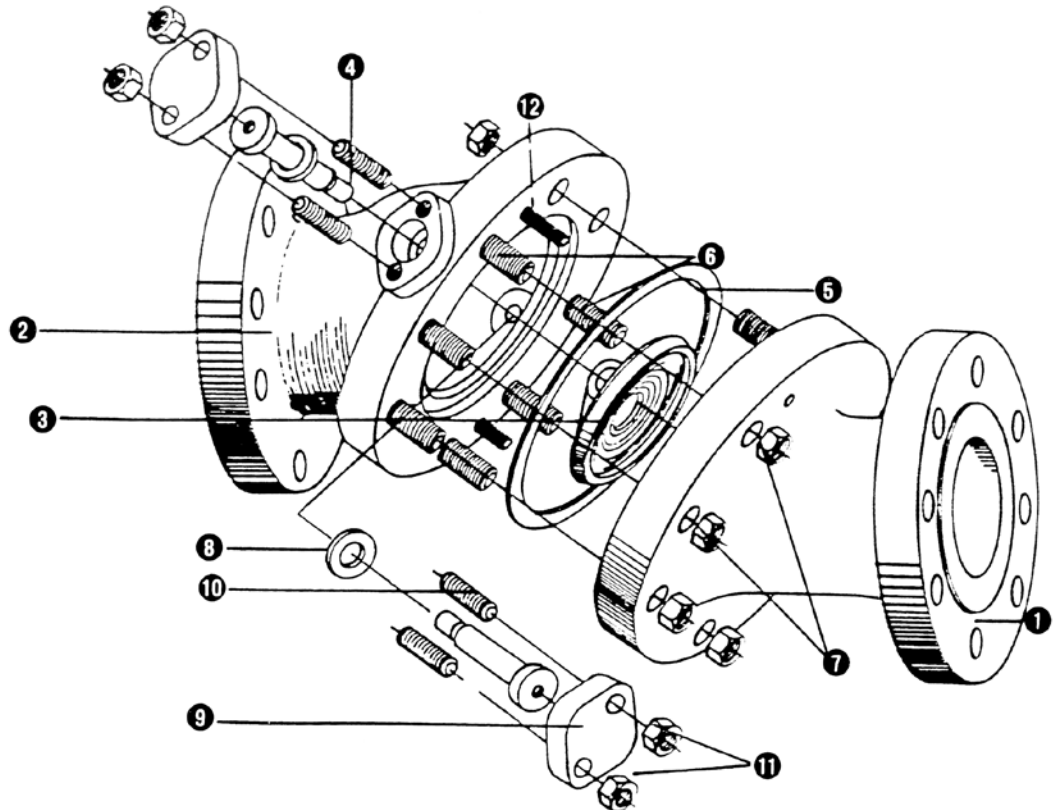

Class 150 • Bolted Cap

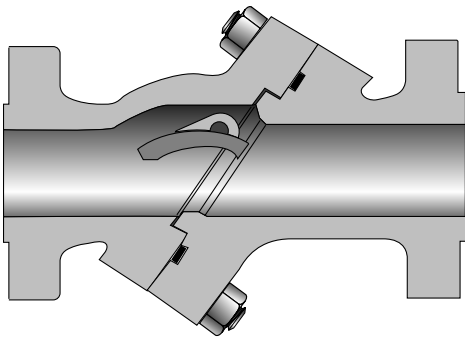

Figure 123

Flanged

Figure 123½

Butt Weld

Size Range:

2 through 36 inches
(50 - 900 mm)

Pressure Temp. Rating

Carbon Steel
ASTM A216 Grade WCB
285 psi @ -20°F to 100°F
(20 bar @ -28°C to 37°C)

Material of Construction*

Description	Material
Inlet Body	ASTM A216 WCB
Outlet Body	ASTM A216 WCB
Disc	13% CR Overlay
Pivot Pin	SS
Body Gasket	Stainless Steel spiral wound Graphite
Body Studs	ASTM A193 B7
Body Nuts	ASTM A194 2H
Bearing Cap	Carbon Steel
Bearing Cap Gaskets	Soft Steel
Bearing Cap Studs	ASTM A193 B7
Bearing Cap Nuts	ASTM A194 2H
Dowel Pins	Carbon Steel

NOTE:

*Standard construction: WCB-Trim 8, other options are available.

Industry Standards

All materials comply with ASME B16.34

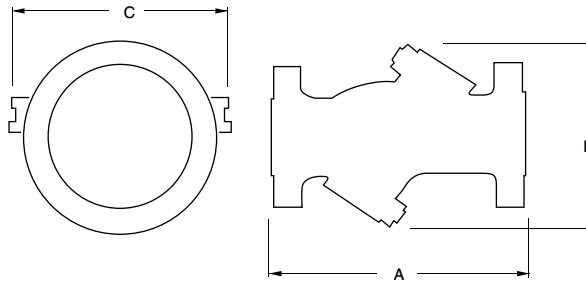

Dimensions and Weights

Inches (millimeters) - pounds (kilograms)

Valves	2 (50)	2 ½ (65)	3 (80)	4 (100)	5 (125)	8 (200)	10 (250)	12 (300)	14 (350)	16 (400)	18 (450)	20 (500)	24 (600)	30 (750)	36 (900)
A	8.00 (203)	8.50 (216)	9.50 (241)	11.50 (292)	13.00 (330)	19.50 (495)	24.50 (622)	27.50 (698)	31.00 (787)	30.00 (762)	33.00 (838)	32.50 (825)	38.00 (965)	49.50 (1257)	59.50 (1511)
B	7 (177)	9 (229)	9 (229)	10 (254)	11 (279)	16 (406)	19 (482)	21 (533)	22 (558)	25 (635)	28 (711)	31 (787)	36 (914)	44 (1117)	50 (1270)
C	8 (203)	9 (229)	9 (229)	13 (330)	16 (406)	21 (533)	25 (635)	28 (711)	29 (736)	34 (863)	36 (914)	39 (990)	45 (1143)	54 (1371)	60 (1524)
Wt. (123)	38 (17)	51 (23)	59 (26)	102 (46)	139 (63)	293 (132)	488 (221)	690 (312)	823 (373)	1070 (485)	1435 (650)	1825 (827)	2887 (1309)	4790 (2172)	6795 (3082)
Wt. (123½)	22 (9)	38 (17)	42 (19)	75 (34)	108 (48)	240 (108)	400 (181)	570 (258)	690 (312)	885 (401)	1213 (550)	1760 (798)	2265 (1027)	4025 (1825)	5755 (2610)

Tilting Disc Check Valve

Figures 323
323½



Class 300 • Bolted Cap

Material of Construction*

Description	Material
Inlet Body	ASTM A216 WCB
Outlet Body	ASTM A216 WCB
Disc	13% CR Overlay
Pivot Pin	SS
Body Gasket	Stainless Steel spiral wound Graphite
Body Studs	ASTM A193 B7
Body Nuts	ASTM A194 2H
Bearing Cap	Carbon Steel
Bearing Cap Gaskets	Soft Steel
Bearing Cap Studs	ASTM A193 B7
Bearing Cap Nuts	ASTM A194 2H
Dowel Pins	Carbon Steel

NOTE:

*Standard construction: WCB-Trim 8, other options are available.

Figure 323

Flanged

Figure 323½

Butt Weld

Size Range:

2 through 36 inches
(50 - 900 mm)

Pressure Temp. Rating

Carbon Steel
ASTM A216 Grade WCB
740 psi @ -20°F to 100°F
(51 bar @ -28°C to 37°C)

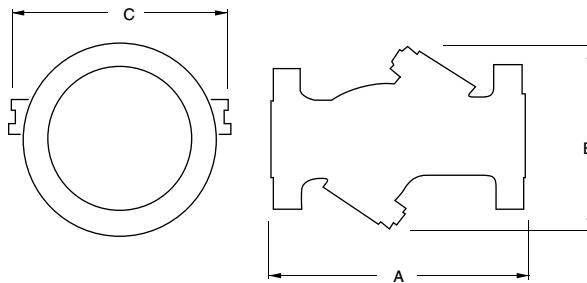
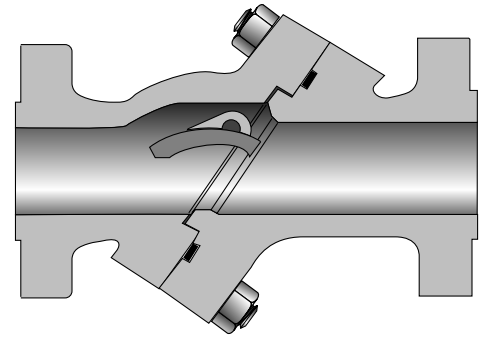

Industry Standards

All materials comply with ASME B16.34

Dimensions and Weights

Inches (millimeters) - pounds (kilograms)

Valves	2 (50)	2½ (65)	3 (80)	4 (100)	5 (125)	8 (200)	10 (250)	12 (300)	14 (350)	16 (400)	18 (450)	20 (500)	24 (600)	30 (750)	36 (900)
A	10.50 (266)	11.50 (292)	12.50 (317)	14.00 (355)	15.75 (400)	21.00 (533)	24.50 (622)	28.00 (711)	30.00 (762)	33.00 (838)	36.00 (914)	39.00 (990)	45.00 (1143)	54.00 (1371)	60.00 (1524)
B	8 (203)	10 (254)	10 (254)	11 (279)	13 (330)	17 (431)	20 (508)	24 (609)	25 (635)	28 (711)	31 (787)	33 (838)	38 (965)	45 (1143)	57 (1447)
C	9 (229)	10 (254)	10 (254)	14 (355)	16 (406)	22 (558)	25 (635)	30 (762)	30 (762)	36 (914)	40 (1016)	41 (1041)	45 (1143)	54 (1371)	68 (1727)
Wt. (323)	38 (17)	51 (23)	59 (26)	102 (46)	139 (63)	293 (132)	488 (221)	690 (312)	823 (373)	1070 (485)	1435 (650)	1825 (827)	2887 (1309)	4790 (2172)	6795 (3082)
Wt. (323½)	22 (9)	38 (17)	42 (19)	75 (34)	108 (48)	240 (108)	400 (181)	570 (258)	690 (312)	885 (401)	1213 (550)	1760 (798)	2265 (1027)	4025 (1825)	5755 (2610)

Class 600 • Bolted Cap

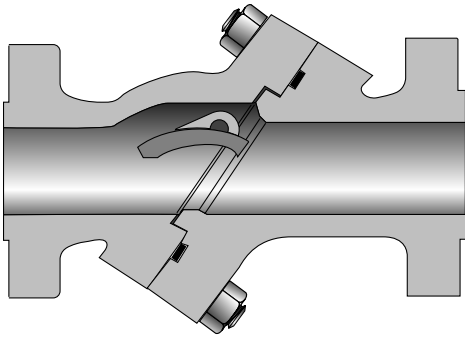

Figure 623

Flanged

Figure 623½

Butt Weld

Size Range:

2 through 30 inches
(50 - 750 mm)

Pressure Temp. Rating

Carbon Steel
ASTM A216 Grade WCB
1480 psi @ -20°F to 100°F
(102 bar @ -28°C to 37°C)

Material of Construction*

Description	Material
Inlet Body	ASTM A216 WCB
Outlet Body	ASTM A216 WCB
Disc	13% CR Overlay
Pivot Pin	SS
Body Gasket	Stainless Steel spiral wound Graphite
Body Studs	ASTM A193 B7
Body Nuts	ASTM A194 2H
Bearing Cap	Carbon Steel
Bearing Cap Gaskets	Soft Steel
Bearing Cap Studs	ASTM A193 B7
Bearing Cap Nuts	ASTM A194 2H
Dowel Pins	Carbon Steel

NOTE:

*Standard construction: WCB-Trim 8, other options are available.

Industry Standards

All materials comply with ASME B16.34

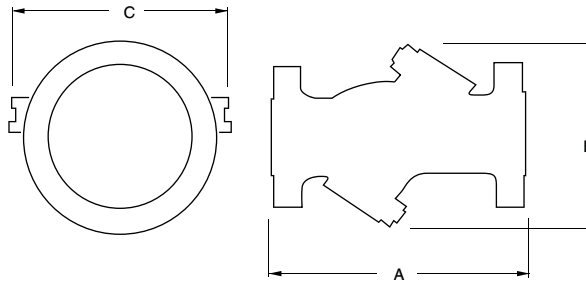

Dimensions and Weights

Inches (millimeters) - pounds (kilograms)

Valves	2 (50)	2½ (65)	3 (80)	4 (100)	5 (125)	6 (150)	8 (200)	10 (250)	12 (300)	14 (350)	16 (400)	18 (450)	20 (500)	24 (600)	30 (750)
A	11.50 (292)	13.00 (330)	14.00 (355)	17.00 (431)	20.00 (508)	22.00 (558)	26.00 (660)	31.00 (787)	33.00 (838)	35.00 (889)	39.00 (990)	43.00 (1092)	47.00 (1193)	55.00 (1397)	59.00 (1498)
B	8 (203)	10 (254)	10 (254)	13 (330)	15 (381)	16 (406)	19 (482)	22 (558)	26 (660)	27 (685)	30 (762)	34 (863)	38 (965)	44 (1117)	49 (1244)
C	9 (229)	10 (254)	10 (254)	16 (406)	19 (482)	20 (508)	24 (609)	28 (711)	31 (787)	33 (838)	36 (914)	43 (1092)	46 (1168)	53 (1346)	60 (1524)
Wt. (623)	68 (30)	110 (49)	115 (52)	222 (100)	327 (148)	432 (195)	725 (328)	1035 (469)	1470 (666)	1830 (830)	2550 (1156)	3570 (1619)	4805 (2179)	7190 (3261)	6925 (3141)
Wt. (623½)	60 (27)	70 (31)	85 (38)	164 (74)	267 (121)	295 (133)	435 (197)	820 (371)	1055 (478)	1335 (605)	1965 (891)	2010 (911)	4545 (2061)	5850 (2653)	7715 (3499)

Tilting Disc Check Valve

Figures 923
923½



Class 900 • Bolted Cap

Material of Construction*

Description	Material
Inlet Body	ASTM A216 WCB
Outlet Body	ASTM A216 WCB
Disc	13% CR Overlay
Pivot Pin	SS
Body Gasket	Stainless Steel spiral wound Graphite
Body Studs	ASTM A193 B7
Body Nuts	ASTM A194 2H
Bearing Cap	Carbon Steel
Bearing Cap Gaskets	Soft Steel
Bearing Cap Studs	ASTM A193 B7
Bearing Cap Nuts	ASTM A194 2H
Dowel Pins	Carbon Steel

NOTE:

*Standard construction: WCB-Trim 8, other options are available.

Figure 923

Flanged

Figure 923½

Butt Weld

Size Range:

3 through 18 inches
(80 - 450 mm)

Pressure Temp. Rating

Carbon Steel

ASTM A216 Grade WCB
2220 psi @ -20°F to 100°F
(153 bar @ -28°C to 37°C)

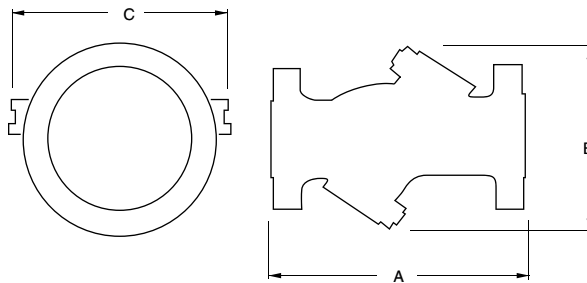
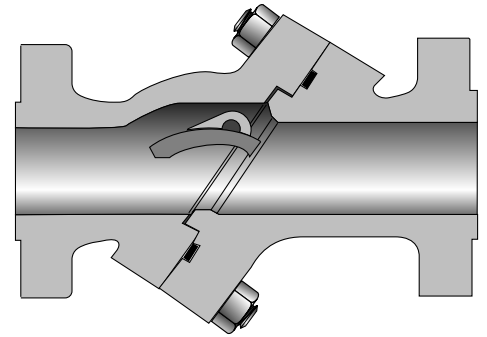

Industry Standards

All materials comply with ASME B16.34

Dimensions and Weights

Inches (millimeters) - pounds (kilograms)

Valves	3 (80)	4 (100)	5 (125)	6 (150)	8 (200)	10 (250)	12 (300)	14 (350)	16 (400)	18 (450)
A	15.00 (381)	18.00 (457)	22.00 (558)	24.00 (609)	29.00 (736)	33.00 (838)	38.00 (965)	40.50 (1028)	44.50 (1130)	48.00 (1219)
B	11 (279)	12 (304)	14 (355)	16 (406)	20 (508)	25 (635)	28 (711)	31 (787)	37 (939)	41 (1041)
C	16 (406)	19 (482)	22 (558)	24 (609)	28 (711)	35 (889)	35 (889)	42 (1066)	45 (1143)	50 (1270)
Wt. (923)	177 (80)	273 (123)	438 (198)	604 (273)	1050 (476)	1770 (802)	2415 (1095)	-	-	-
Wt. (923½)	107 (48)	164 (74)	286 (129)	464 (210)	760 (344)	1440 (653)	1610 (730)	2010 (911)	2260 (1025)	2515 (1140)

Class 1500 • Bolted Cap

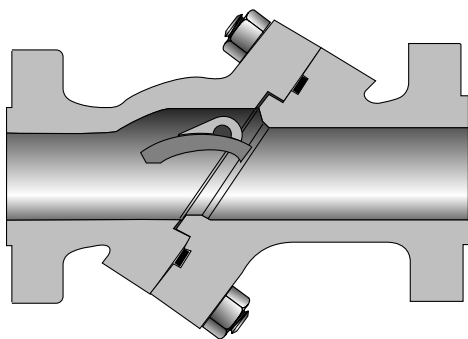

Figure 1523

Flanged

Figure 1523½

Butt Weld

Size Range:

2 through 10 inches
(50 - 250 mm)

Pressure Temp. Rating

Carbon Steel
ASTM A216 Grade WCB
3705 psi @ -20°F to 100°F
(256 bar @ -28°C to 37°C)

Material of Construction*

Description	Material
Inlet Body	ASTM A216 WCB
Outlet Body	ASTM A216 WCB
Disc	13% CR Overlay
Pivot Pin	SS
Body Gasket	Stainless Steel spiral wound Graphite
Body Studs	ASTM A193 B7
Body Nuts	ASTM A194 2H
Bearing Cap	Carbon Steel
Bearing Cap Gaskets	Soft Steel
Bearing Cap Studs	ASTM A193 B7
Bearing Cap Nuts	ASTM A194 2H
Dowel Pins	Carbon Steel

NOTE:

*Standard construction: WCB-Trim 8, other options are available.

Industry Standards

All materials comply with ASME B16.34

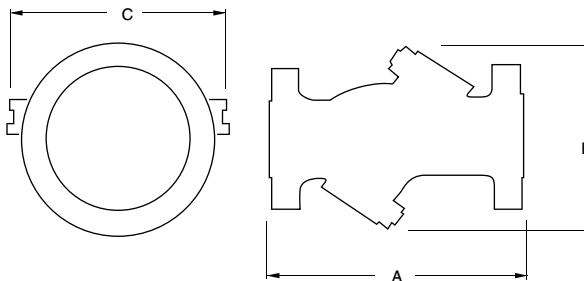

Dimensions and Weights

Inches (millimeters) - pounds (kilograms)

Valves	2 (50)	2½ (65)	3 (80)	4 (100)	6 (150)	8 (200)	10 (250)
A	14.50 (368)	16.50 (419)	18.50 (469)	21.50 (546)	27.75 (704)	32.75 (831)	39.00 (990)
B	12 (304)	12 (304)	12 (304)	15 (381)	19 (482)	22 (558)	29 (736)
C	17 (431)	17 (431)	17 (431)	21 (533)	24 (609)	30 (762)	38 (965)
Wt. (1523)	177 (80)	273 (123)	438 (198)	604 (273)	1050 (476)	1770 (802)	2415 (1095)
Wt. (1523½)	107 (48)	164 (74)	286 (129)	464 (210)	760 (344)	1440 (653)	1610 (730)

Stop Check Valve Information

Stop Check Valves are as essential to safe operation of a boiler plant as safety valves or other safety devices attached to the boiler.

When more than one boiler is connected to the main steam header, a stop check valve should be installed in the pipeline between each boiler and the header.

The valve should always be placed so that the pressure in the boiler is under the disc. Straightway valves may be used in horizontal or vertical lines for upward flow. Angle valves may be used for upward horizontal or horizontal downward flow.

Features

Valve designed for steam application that operate between 100 psi (9 bar) and 375 psi (26 bar).

The Stop Check feature of this valve requires a minimum of 50 psi (3.5 bar) pressure differential between the piping system and the boiler to operate correctly.

For installation between boilers supplying the same steam header, and positioned with pressure under the disc. Straightway is for horizontal or vertical line with upward flow. Angle valves are for "horizontal-downward" or "upward-horizontal" flow.

These valves will perform the four following important functions:

1. Act as an automatic-non return valve applied as a containment device to prevent gross backflow of steam from main header to boiler in case the boiler fails.
2. Assist in cutting out boiler, when ceasing to fire and boiler is blown down. In this case, valve disc automatically closes to restrict backflow of steam to the boiler.

3. Assist in returning boiler after a shutdown.
4. Restricts backflow of steam from header into boiler which has been shut down and opened or suffered a pressure containment blowout. The check valve feature should not be relied upon for primary shut-off.

Cylindrical shaped disc is the only pressure-actuated part, light in weight with ample guiding surface. It is specially designed to produce a maximum lift at minimum velocities. There are no wing guides to cause "spinning" with resultant rapid wear.

Notes

Cylindrical-Shaped Disc is the only moving part. It is especially designed to produce maximum lift at minimum velocities. There are no wing guides to cause "spinning" with resultant rapid wear.

Long Throttling Lip on the disc retards flow when seating position is approached. Disc chattering is prevented, and wiredrawing of seating surfaces is reduced.

Removable Liner guides the disc throughout the full travel. Being entirely independent of the body, it is not subject to distortion by expansion strains.

Piston Ring adds to dashpot's ability to avoid rapid disc movement and where pulsations are extremely severe, two piston rings can be installed.

Easy Regrinding Tap Bosses on top of the disc permit inserting nipples or eye bolts to facilitate quick removal of the disc for grinding.

Large Port Areas in the liner produce only a minimum of pressure drop through the valve and assure unrestricted movement of the disc.

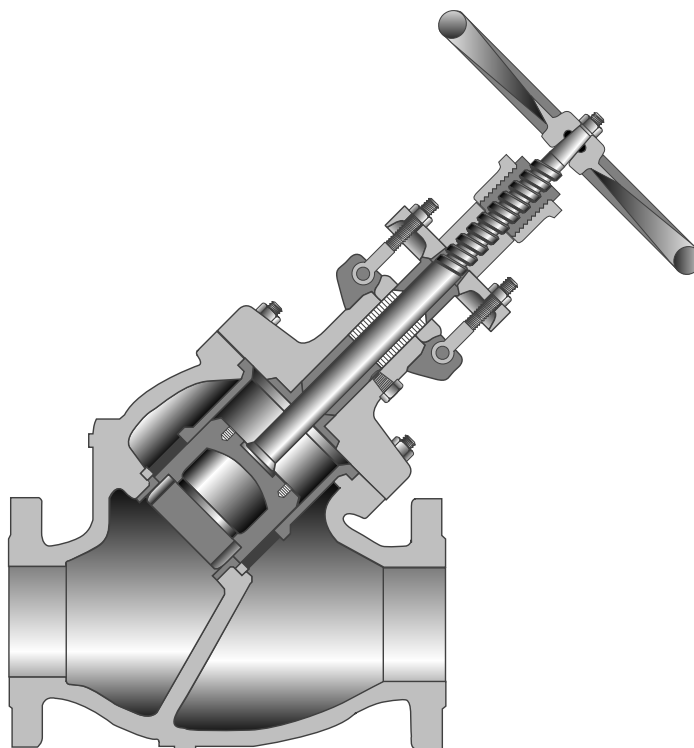

Class 300 • Outside Screw & Yoke • Bolted Bonnet

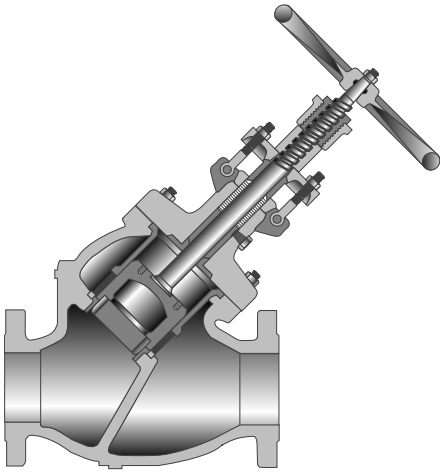

Figure 28
Flanged
Figure 28½
Butt Weld

Size Range:
3 through 10 inches
(80 - 250 mm)

Pressure Temperature Rating
Carbon Steel
ASTM A216 Grade WCB
740 psi @ -20°F to 100°F
(51 bar @ -28°C to 37°C)

Notes

- Butt weld ends on valves 10" (250 mm) and smaller are bored to match standard pipe unless otherwise specified. For larger valves, diameter (I.D. of pipe) of bore must be specified.
- Sizes 8" and 10" (200 mm & 250 mm), Class 300 are equipped with a hammer-blow handwheel.

Industry Standards

Steel Valves	ASME B16.34
Face-to-Face/End-to-End	ASME B16.10
Flange Dimensions	ASME B16.5
Weld End	ASME B.16.25
Testing	API 598

Material of Construction*

Description	Material
Body	ASTM A216 WCB
Bonnet	ASTM A216 WCB
Disc	Hardfaced
Stem	13% Chrome
Body Gasket	Soft Steel
Body Studs	ASTM A194 B7
Body Nuts	ASTM A194 2H
Eyebolts	Carbon Steel
Groove Pins	Carbon Steel
Liner	13% Chrome
Seat	13% Chrome
Gland	13% Chrome
Gland Flange	Carbon Steel
Handwheel	Ductile Iron
Yokesleeve	Bronze

NOTE:

*Standard construction: WCB-Trim 8, other options are available.

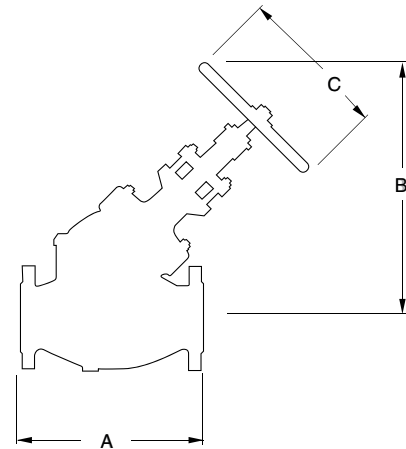

Dimensions and Weights

Inches (millimeters) - pounds (kilograms)

Valves	3 (80)	4 (100)	6 (150)	8 (200)	10 (250)
A	14.75 (374)	17.00 (431)	21.50 (546)	26.00 (660)	30.00 (762)
B	22 (558)	27 (685)	34 (863)	41 (1041)	48 (1219)
C	10 (254)	14 (355)	18 (457)	20 (508)	30 (762)
Wt. (28)	140 (63)	260 (117)	430 (195)	770 (349)	1320 (598)
Wt. (28½)	125 (56)	225 (102)	395 (179)	755 (342)	1265 (573)

Stop Check Valve

Figures 30
30½



Class 300 • Outside Screw & Yoke • Bolted Bonnet

Material of Construction*

Description	Material
Body	ASTM A216 WCB
Bonnet	ASTM A216 WCB
Disc	Hardfaced
Stem	13% Chrome
Body Gasket	Soft Steel
Body Studs	ASTM A194 B7
Body Nuts	ASTM A194 2H
Eyebolts	Carbon Steel
Groove Pins	Carbon Steel
Liner	13% Chrome
Seat	13% Chrome
Gland	13% Chrome
Gland Flange	Carbon Steel
Handwheel	Ductile Iron
Yokesleeve	Bronze

NOTE:

*Standard construction: WCB-Trim 8, other options are available.

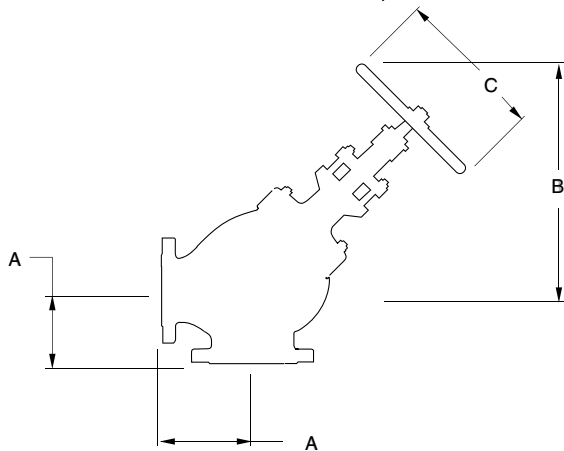

Dimensions and Weights

Inches (millimeters) - pounds (kilograms)

Valves	3 (80)	4 (100)	6 (150)	8 (200)	10 (250)
A	6.25 (158)	7.00 (177)	8.75 (222)	10.50 (266)	12.25 (311)
B	17 (431)	21 (533)	27 (685)	32 (812)	38 (965)
C	10 (254)	14 (355)	18 (457)	20 (508)	30 (762)
Wt. (30)	120 (54)	200 (90)	370 (167)	680 (308)	1120 (508)
Wt. (30½)	90 (40)	160 (72)	320 (145)	570 (258)	970 (439)

Figure 30

Flanged

Figure 30½

Butt Weld

Size Range:

3 through 10 inches
(80 - 250 mm)

Pressure Temperature Rating

Carbon Steel
ASTM A216 Grade WCB
740 psi @ -20°F to 100°F
(51 bar @ -28°C to 37°C)

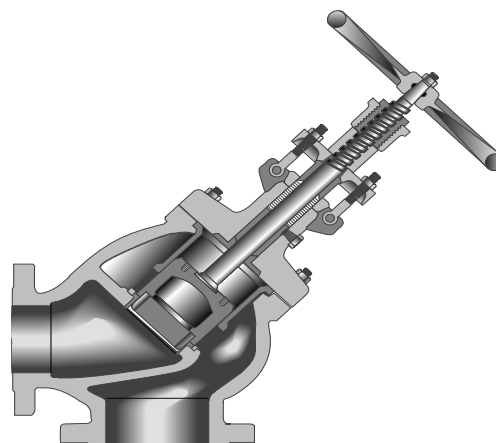

Notes

Butt weld ends on valves 10" (250 mm) and smaller are bored to match standard pipe unless otherwise specified. For larger valves, diameter (I.D. of pipe) of bore must be specified.

Industry Standards

Steel Valves	ASME B16.34
Face-to-Face/End-to-End	ASME B16.10
Flange Dimensions	ASME B16.5
Weld End	ASME B.16.25
Testing	API 598

Technical Data

Selecting the Proper Size – Determining Pressure Drop

Since stop-check valves have a floating disc member, it is important the valve be sized to provide full disc lift under flow conditions prevailing during the major portion of the service life. If the valve is too large, the disc will float in a partially open position and may cause fluttering of the disc and rapid wear. Conversely, if the valve is too small, pressure drop will be excessive.

The chart on the opposite page is a graphic representation of flow data determined by test. Its use offers a simple method of determining the best size of stop-check valve, as well as the pressure drop under varying conditions of flow, without any computation.

How to Use the Chart Shown on the Opposite Page

Given: Steam pressure-Temperature...300 psig 750°F
Flow Rate...Typical Daily Demand Curve

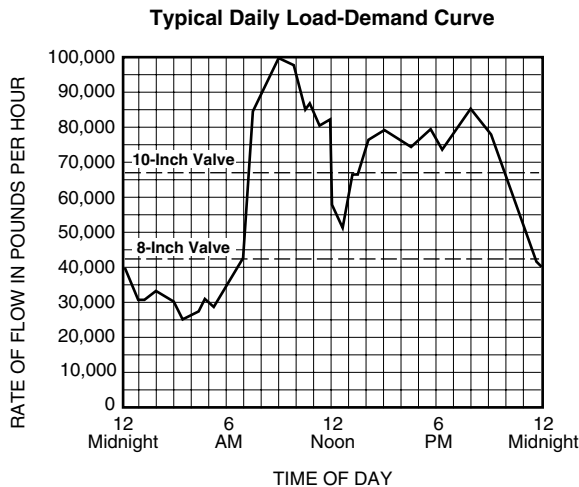

Find: Valve Catalog No. and the best size for above installation.

Solution: Reference to the pressure-temperature ratings on page 32 and 33 indicates a Class 300 valve will be required. Therefore, the following valves may be used:

- Globe...No. 28 XU, Flanged or No. 28½ XU, Butt-Welding
- Angle...No. 30 XU, Flanged or No. 30½ XU, Butt-Welding

1. Enter the Temperature chart at 750°F (399°C). Move vertically upward to the curved line for 300 psi (21 bar), then horizontally to the right to establish a point on the specific volume scale. From this point, draw a line through the flow rate being investigated (100,000 Lb/H) and establish a point on Index 1.

2. From that point, draw another line through the valve size, for example the 8-inch (200 mm) size, and establish a point on Index 2. Now move horizontally to the diagonal pressure drop line on the right side. Where these lines intersect, the pressure drop is 9 psi (.62 bar) for the 8-inch (200 mm), Class 300 globe valve and 10 psi (.69 bar) for the 8-inch (200 mm), Class 300 angle valve.

Chart solutions resulting in a point on Index 2 that falls below the Line A-A for Class 300 valves or below Line B-B for class 600 valves indicate the disc will not be fully lifted under the flow conditions used. Operation under such conditions is not recommended but, at times, must be tolerated for short periods during the low loads.

3. Enter the chart where Line A-A intersects Index 2 for Class 300 valves or below the Line B-B for Class 600 valves. Move diagonally upward through the size being investigated 8-inch (200 mm) and establish a second point on Index 1. From this point, extend a line to the specific volume established in Step 1 and at its intersection with the flow rate line, read 42,000 Lb/H as the minimum flow rate at which the disc will be in the fully lifted position. The pressure drop at this flow rate is 1.9 psi (.13 bar) for globe and 2.1 psi (.14 bar) for angle valves.

4. Repeat Steps 2 and 3 for other possible valve sizes, tabulate results, and make size selection on basis of pressure drop and duration of partial disc lift considerations.

Valve Size	Press Drop @max. min. flow rate (100,000 #/Hr.), psi (bar)		Flow rate for wide open valve #/Hr.
	Globe	Angle	
6" (150 mm)	24.0 (1.65)	26.0 (1.79)	24,000
8" (200 mm)	9.0 (.62)	10.0 (.68)	42,000
10" (250 mm)	3.8 (.26)	4.2 (.28)	68,000
12" (300 mm)	2.1 (.14)	2.3 (.15)	95,000

Dotted lines on Demand Curve indicate minimum flow rates for wide open 8" and 10" (200 mm and 250 mm) valves.

5. The best choice for this example would be the 10" (250 mm) size because pressure drop is much lower and duration of partially lifted disc is only slightly greater than for the 8" (200 mm) size.

6. Pressure drop for any intermediate flow condition can be determined as outlined in Steps 1 and 2.

Technical Data

Crane Bolted Bonnet Stop-Check Valves Selecting the Proper Size – Determining Pressure Drop

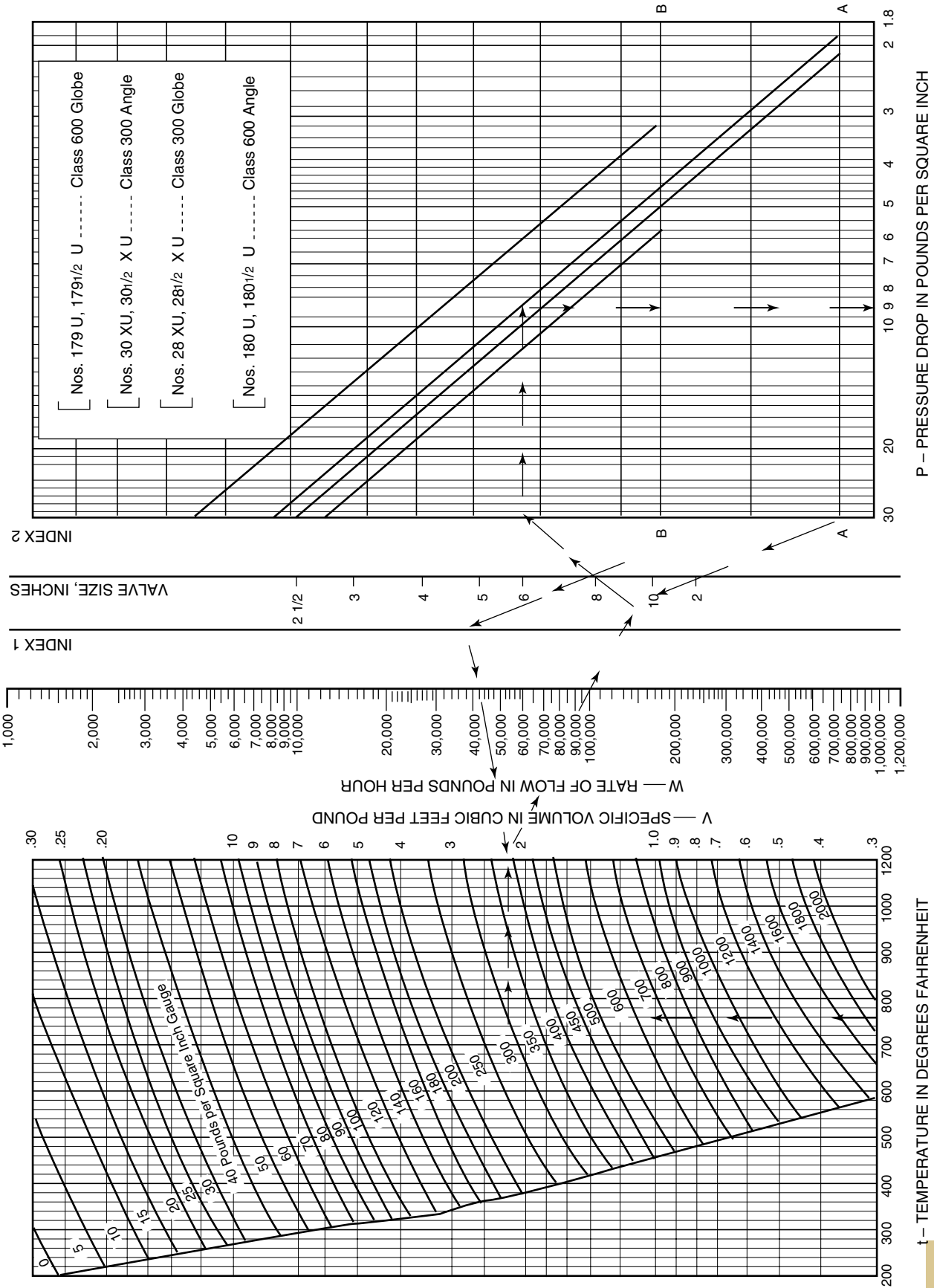

Y-Pattern Stop-Check and Isolation Gate Valves

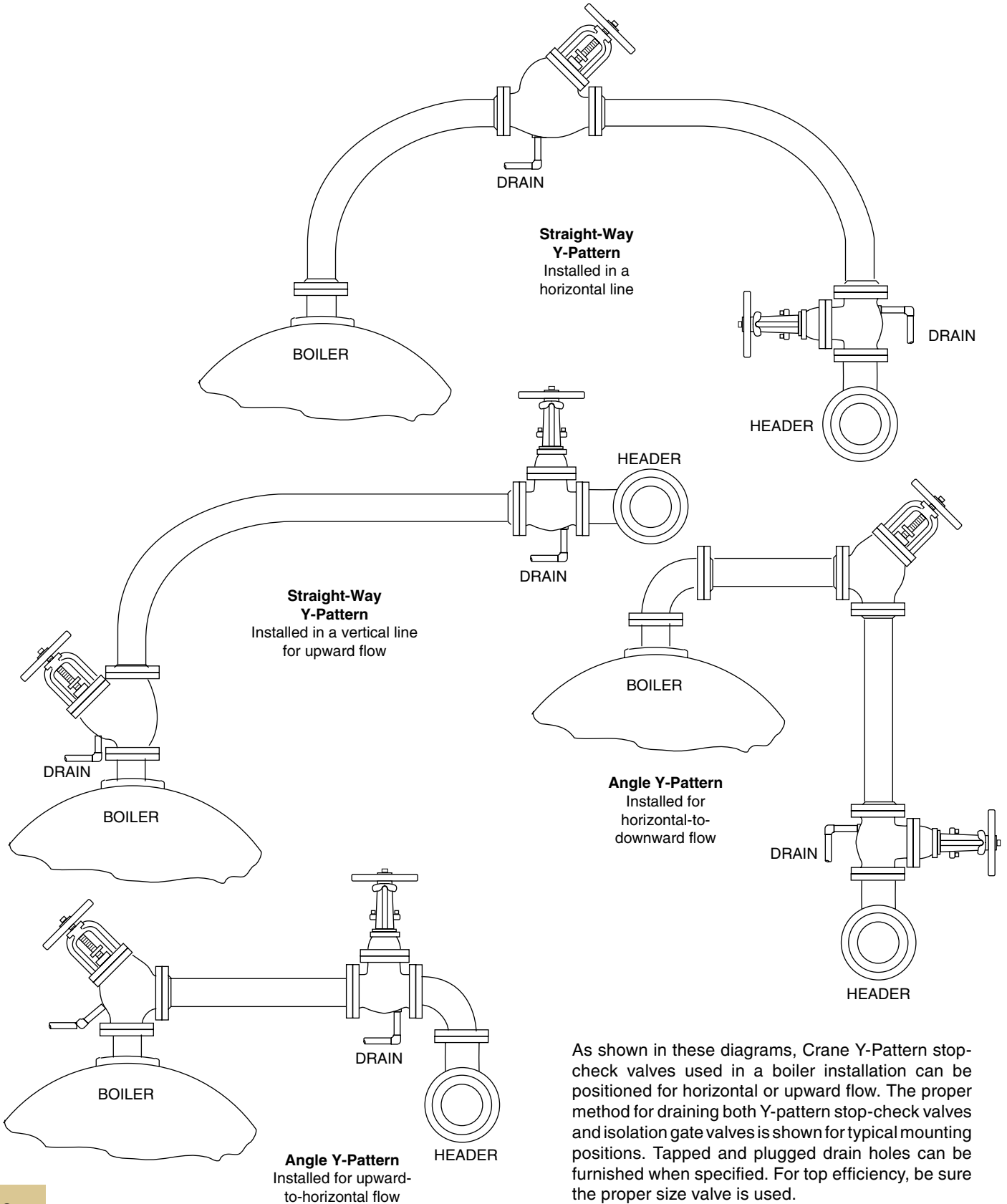

Pressure-Temperature Ratings

ENGLISH UNITS

The following pressure-temperature charts are derived from ASME B16.34 – 2004 Version. They will cover the most commonly used body and bonnet materials in the industry. All Crane Valves are designed to operate through the pressure and temperature ranges shown in these charts for a particular ASME Class Rating and ASTM Material.

ASTM A216 GR WCB

°F	STANDARD CLASS B16.34 - 2004 MAXIMUM NON-SHOCK WORKING PRESSURE, PSIG						SPECIAL CLASS B16.34 - 2004* MAXIMUM NON-SHOCK WORKING PRESSURE, PSIG					
	150	300	600	900	1500	2500	150	300	600	900	1500	2500
-20 to 100	285	740	1480	2220	3705	6170	290	750	1500	2250	3750	6250
200	260	680	1360	2035	3395	5655	290	750	1500	2250	3750	6250
300	230	655	1310	1965	3270	5450	285	740	1480	2220	3700	6170
400	200	635	1265	1900	3170	5280	280	735	1465	2200	3665	6105
500	170	605	1205	1810	3015	5025	280	735	1465	2200	3665	6105
600	140	570	1135	1705	2840	4730	280	735	1465	2200	3665	6105
650	125	550	1100	1650	2745	4575	275	715	1430	2145	3575	5960
700	110	530	1060	1590	2665	4425	265	690	1380	2075	3455	5760
750	95	505	1015	1520	2535	4230	245	635	1270	1905	3170	5285
800	80	410	825	1235	2055	3430	195	515	1030	1545	2570	4285

NOTE: Upon prolonged exposure to temperatures above 800°F (426°C), the carbide phase of steel may be converted to graphite. Permissible, but not recommended for prolonged use above 800°F (426°C).

ASTM A352 GR LCB

°F	STANDARD CLASS B16.34 - 2004 MAXIMUM NON-SHOCK WORKING PRESSURE, PSIG						SPECIAL CLASS B16.34 - 2004* MAXIMUM NON-SHOCK WORKING PRESSURE, PSIG					
	150	300	600	900	1500	2500	150	300	600	900	1500	2500
-20 to 100	265	695	1395	2090	3480	5805	290	695	1395	2090	3480	5805
200	255	660	1320	1980	3300	5505	290	695	1395	2090	3480	5805
300	230	640	1275	1915	3190	5315	290	695	1395	2090	3480	5805
400	200	615	1230	1845	3075	5125	290	695	1395	2090	3480	5805
500	170	585	1175	1760	2930	4885	290	695	1395	2090	3480	5805
600	140	550	1105	1655	2755	4595	290	695	1395	2090	3480	5805
650	125	535	1065	1600	2665	4440	290	695	1390	2080	3470	5780

NOTE: Not to be used over 650°F (343°C).

ASTM A352 GR LCC & LC3

°F	STANDARD CLASS B16.34 - 2004 MAXIMUM NON-SHOCK WORKING PRESSURE, PSIG						SPECIAL CLASS B16.34 - 2004* MAXIMUM NON-SHOCK WORKING PRESSURE, PSIG					
	150	300	600	900	1500	2500	150	300	600	900	1500	2500
-20 to 100	290	750	1500	2250	3750	6250	290	750	1500	2250	3750	6250
200	260	750	1500	2250	3750	6250	290	750	1500	2250	3750	6250
300	230	730	1455	2185	3640	6070	290	750	1500	2250	3750	6250
400	200	705	1405	2110	3520	5865	290	750	1500	2250	3750	6250
500	170	665	1330	1995	3325	5540	290	750	1500	2250	3750	6250
600	140	605	1210	1815	3025	5040	290	750	1500	2250	3750	6250
650	125	590	1175	1765	2940	4905	290	750	1500	2250	3750	6250

NOTE: Not to be used over 650°F (343°C).

* “Special Class” applies to weld-end valves only and requires NDE testing in accordance with ASME B16.34 - 2004.

ASME Pressure Temperature Ratings

ENGLISH UNITS

ASTM A217 GR WC6

°F	STANDARD CLASS B16.34 - 2004						SPECIAL CLASS B16.34 - 2004*					
	MAXIMUM NON-SHOCK WORKING PRESSURE, PSIG						MAXIMUM NON-SHOCK WORKING PRESSURE, PSIG					
	150	300	600	900	1500	2500	150	300	600	900	1500	2500
-20 to 100	290	750	1500	2250	3750	6250	290	750	1500	2250	3750	6250
200	260	750	1500	2250	3750	6250	290	750	1500	2250	3750	6250
300	230	720	1445	2165	3610	6015	290	750	1500	2250	3750	6250
400	200	695	1385	2080	3465	5775	290	750	1500	2250	3750	6250
500	170	665	1330	1995	3325	5540	290	750	1500	2250	3750	6250
600	140	605	1210	1815	3025	5040	290	750	1500	2250	3750	6250
650	125	590	1175	1765	2940	4905	290	750	1500	2250	3750	6250
700	110	570	1135	1705	2840	4730	280	735	1465	2200	3665	6110
750	95	530	1065	1595	2660	4430	280	730	1460	2185	3645	6070
800	80	510	1015	1525	2540	4230	275	720	1440	2160	3600	6000
850	65	485	975	1460	2435	4060	260	680	1355	2030	3385	5645
900	50	450	900	1350	2245	3745	225	585	1175	1760	2935	4895
950	35	320	640	955	1595	2655	155	400	795	1195	1995	3320
1000	20	215	430	650	1080	1800	105	270	540	810	1350	2250
1050	20	145	290	430	720	1200	70	180	360	540	900	1500
1100	20	95	190	290	480	800	45	120	240	360	600	1000

NOTE: Use normalized and tempered material only. Not to be used over 1100°F (593°C). Flanged end valve ratings terminate at 1000°F (537°C).

ASTM A217 GR WC9

°F	STANDARD CLASS B16.34 - 2004						SPECIAL CLASS B16.34 - 2004*					
	MAXIMUM NON-SHOCK WORKING PRESSURE, PSIG						MAXIMUM NON-SHOCK WORKING PRESSURE, PSIG					
	150	300	600	900	1500	2500	150	300	600	900	1500	2500
-20 to 100	290	750	1500	2250	3750	6250	290	750	1500	2250	3750	6250
200	260	750	1500	2250	3750	6250	290	750	1500	2250	3750	6250
300	230	730	1455	2185	3640	6070	285	740	1480	2220	3695	6160
400	200	705	1410	2115	3530	5880	280	730	1455	2185	3640	6065
500	170	665	1330	1995	3325	5540	280	725	1450	2175	3620	6035
600	140	605	1210	1815	3025	5040	275	720	1440	2165	3605	6010
650	125	590	1175	1765	2940	4905	275	715	1430	2145	3580	5965
700	110	570	1135	1705	2840	4730	270	705	1415	2120	3535	5895
750	95	530	1065	1595	2660	4430	270	705	1415	2120	3535	5895
800	80	510	1015	1525	2540	4230	270	705	1415	2120	3535	5895
850	65	485	975	1460	2435	4060	260	680	1355	2030	3385	5645
900	50	450	900	1350	2245	3745	230	600	1200	1800	3000	5000
950	35	385	755	1160	1930	3220	180	470	945	1415	2630	3930
1000	20	265	535	800	1335	2230	130	335	670	1005	1670	2785
1050	20	175	350	525	875	1455	85	220	435	655	1095	1820
1100	20	110	220	330	550	915	55	135	275	410	685	1145

NOTE: Use normalized and tempered material only. Not to be used over 1100°F (593°C). Flanged end valve ratings terminate at 1000°F (537°C).

* "Special Class" applies to weld-end valves only and requires NDE testing in accordance with ASME B16.34 - 2004.

ASME Pressure Temperature Ratings

ENGLISH UNITS

ASTM A217 GR C5

°F	STANDARD CLASS B16.34 - 2004 MAXIMUM NON-SHOCK WORKING PRESSURE, PSIG						SPECIAL CLASS B16.34 - 2004* MAXIMUM NON-SHOCK WORKING PRESSURE, PSIG					
	150	300	600	900	1500	2500	150	300	600	900	1500	2500
-20 to 100	290	750	1500	2250	3750	6250	290	750	1500	2250	3750	6250
200	260	750	1500	2250	3750	6250	290	750	1500	2250	3750	6250
300	230	730	1445	2185	3640	6070	290	750	1500	2250	3750	6250
400	200	705	1410	2115	3530	5880	290	750	1500	2250	3750	6250
500	170	665	1330	1995	3325	5540	290	750	1500	2250	3750	6250
600	140	605	1210	1815	3025	5040	290	750	1500	2250	3750	6250
650	125	590	1175	1765	2940	4905	290	750	1500	2250	3750	6250
700	110	570	1135	1705	2840	4730	280	735	1465	2200	3665	6110
750	95	530	1065	1595	2660	4430	280	730	1460	2185	3645	6070
800	80	510	1015	1525	2540	4230	275	720	1440	2160	3600	6000
850	65	485	975	1460	2435	4060	260	615	1225	1840	3065	5105
900	50	375	745	1120	1870	3115	230	465	935	1400	2335	3895
950	35	275	550	825	1370	2285	170	345	685	1030	1715	2855
1000	20	200	400	595	995	1655	125	250	495	745	1245	2070
1050	20	145	290	430	720	1200	90	180	360	540	900	1500
1100	20	100	200	300	495	830	60	125	250	375	620	1035
1150	20	60	125	185	310	515	40	75	155	230	385	645
1200	15	35	70	105	170	285	20	45	85	130	215	355

NOTE: Use normalized and tempered material only. Flanged end valve ratings terminate at 1000°F (537°C).

ASTM A217 GR C12

°F	STANDARD CLASS B16.34 - 2004 MAXIMUM NON-SHOCK WORKING PRESSURE, PSIG						SPECIAL CLASS B16.34 - 2004* MAXIMUM NON-SHOCK WORKING PRESSURE, PSIG					
	150	300	600	900	1500	2500	150	300	600	900	1500	2500
-20 to 100	290	750	1500	2250	3750	6250	290	750	1500	2250	3750	6250
200	260	750	1500	2250	3750	6250	290	750	1500	2250	3750	6250
300	230	730	1455	2185	3640	6070	290	750	1500	2250	3750	6250
400	200	705	1410	2115	3530	5880	290	750	1500	2250	3750	6250
500	170	665	1330	1995	3325	5540	290	750	1500	2250	3750	6250
600	140	605	1210	1815	3025	5040	290	750	1500	2250	3750	6250
650	125	590	1175	1765	2940	4905	290	750	1500	2250	3750	6250
700	110	570	1135	1705	2840	4730	280	735	1465	2200	3665	6110
750	95	530	1065	1595	2660	4430	280	730	1460	2185	3645	6070
800	80	510	1015	1525	2540	4230	275	720	1440	2160	3600	6000
850	65	485	975	1460	2435	4060	260	680	1355	2030	3385	5646
900	50	450	900	1350	2245	3745	230	600	1200	1800	3000	5000
950	35	375	755	1130	1885	3145	180	470	945	1415	2355	3930
1000	20	255	505	760	1270	2115	120	315	635	950	1585	2645
1050	20	170	345	515	855	1430	80	215	430	645	1070	1785
1100	20	115	225	340	565	945	55	140	285	425	705	1180
1150	20	75	150	225	375	630	35	95	190	285	470	785
1200	20	50	105	155	255	430	25	65	130	195	320	535

NOTE: Use normalized and tempered material only. Flanged end valve ratings terminate at 1000°F (537°C).

* "Special Class" applies to weld-end valves only and requires NDE testing in accordance with ASME B16.34 - 2004.

CRANE[®]

Energy Flow Solutions

The Valve Network
Email: sales@thevalvenetwork.com

WWW.THEVALVENETWORK.COM



TVN

— THE VALVE NETWORK —
POWERING RELIABILITY