

Certificate

I am a duly registered environmental Health Specialist in the State of California. My registration number is 6884. I have completely and thoroughly reviewed the site described as Assessor's Parcel Number 023-010-001 and, in accordance with the County Land Use and Development Code, Chapter VI, and my field inspection and tests, the attached design is submitted.

I will make field inspections to determine that the facilities are constructed in accordance with my design. I hereby certify that these facilities as recommended and designed have been designed in accord with sound engineering principles, and satisfactory performance is expected. However, the state of the art sewage disposal system design is such that no guarantee can be made as to the length of time that satisfactory service will occur.

I understand that, prior to requesting a sewage disposal system construction permit final approval, I will have to certify in writing to the permit file that the installation described above has been installed in conformance with the construction design.

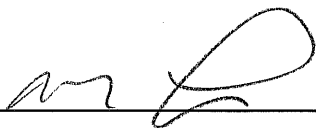

Marc Lindbloom, REHS #6884

Date: 4/14/26

REVIEWED AND ACCEPTED

NEVADA COUNTY ENVIRONMENTAL HEALTH DEPARTMENT
Reviewed and accepted in conformance with NCDEH Local Area
Management Plan (LAMP) and other applicable requirements. Structures
on this site plan have not been reviewed for approval.

By: Carrie McReynolds Date: 05/26/2026

For: E#26-0131 Septic for 5 Occupant Rooming House
ONLY

JOB COPY



Community Development Agency
Environmental Health

950 Maidu Avenue, Suite #170
PO BOX #599002
Nevada City, CA 95959
PH: (530) 265-1222 ext. 3
FAX: (530) 265-9854

Env.Health@nevadacountyca.gov
www.nevadacountyca.gov/eh

APPLICATION FOR A VARIANCE
FROM THE SEWAGE DISPOSAL ORDINANCE

A variance can only be given to reduce or modify a requirement, not eliminate it entirely. In reviewing a variance, sufficient information must be provided by the applicant so that the Director can make a finding that there will not be a health hazard or pollution created.

Assessor's Parcel Number: 023-010-001 Septic Permit No.
Site Address: 13668 AUBURN RD, GRASS VALLEY
Applicant's Name: NEVADA COUNTY HEALTH + HUMAN SERVICES Phone No. (530) 205-7986
Applicant's Email: BRENDAN.PHILLIPS@NEVADA.COUNTY.CA.GOV

I am applying for a variance from Section(s) T-088(2)(I) of the
Administrative and/or Technical Regulations and/or Sewage Disposal Ordinance

Specifically, I am requesting a variance to allow: (describe specifically what the variance is needed for, eg., "to reduce the leachfield setback to a property line from 50 ft to 35 ft") A REDUCTION OF THE MINIMUM AMOUNT OF EFFECTIVE SOIL DEPTH FROM 24" TO 12"

The following special circumstance(s) exist(s) for the property that create(s) a unique hardship, or that will deprive me of privileges enjoyed for other property in the vicinity and zoning district in which the property is located: (e.g., "small parcels were created in this subdivision 20 years ago when property setbacks were smaller; other properties along this street all have property setback variances because of this; I cannot develop the parcel without the variance due to the setback constraints.") A SEPTIC SYSTEM REPAIR CANNOT BE PERFORMED THAT WILL MEET THE EFFECTIVE SOIL DEPTH REQUIREMENT

I have attached supplemental information with my variance application: (Please list attachments provided)

I hereby certify the statements and attachments in this variance application are true and accurate to the best of my knowledge. I further certify that any hardship(s) described above was/were not intentionally cause by me.

Applicant's Signature

4/24/26
Date

This variance application will be routed to Department staff most familiar with this job for review and recommendation. The Director will either approve, conditionally approve, or deny it in writing within fifteen (15) days from the date a completed application was received.

JOB COPY



Soil Depth Variance Request for EH26-0131

May 26, 2026

Marc Lindbloom
PO Box 975
Grass Valley, CA 95945

RE: Variance Request for 13668 Auburn Rd, Grass Valley
APN 023-010-001

Dear Mr. Lindbloom:

You have submitted a request for a variance as required in Section T-088 (2)(I), Supplemental Treatment System Requirements from the Nevada County Sewage Disposal Regulations, which was adopted as Resolution by Chapter L-VI of the Nevada County Land Use & Development Code. This regulation requires that any supplemental treatment system proposed to be installed shall demonstrate a minimum of two (2) feet of effective soil depth beneath the disposal trench bottom. Your variance request proposes installing a Pressure Dose Advantex sewage disposal system with 12 inches of effective soil below the trench bottom.

Section A-030 of the Nevada County Sewage Disposal Regulations specifies the method by which variances may be approved. Typically, a variance can only be given to reduce or modify a requirement, not eliminate it entirely. Sufficient information must be provided so that the findings can be made by the Director that there will not be a health hazard or contamination of the ground water created.

Factors considered in this variance include:

1. Soil testing was performed and determined that suitable soil for sewage disposal is available.
2. The storage area of the leach lines has been increased to mitigate the shallow soil.
3. A UV treatment light will be used prior to effluent discharge to the leach field.
4. A Pressure Dose Advantex sewage disposal system has been designed for the sewage disposal system which requires annual Maintenance and Monitoring to ensure that the disposal system is functioning as designed for the lifespan of the system.
5. The hardship was not intentionally caused by action of the applicant.

Department staff and a consulting Registered Environmental Health Specialist familiar in the design and operation of on-site sewage disposal systems have evaluated site conditions. Adequate consideration has been given to the proposed sewage disposal system design, and proper functioning is expected. Therefore, no pollution or degradation of the groundwater is anticipated from a sewage disposal system that meets current requirements.

In consideration of these factors, the following findings are made:

- The soil depth will not affect the effluent treatment and cause a health hazard.

JOB COPY

- Granting the variance would not have any significant adverse environmental effect and would not significantly affect use of adjoining property; and
- Following the requirements of the ordinance would not present a public health hazard or the pollution or degradation of public waters.

Therefore, the variance is granted for the installation of a Pressure Dose Advantex Sewage Disposal Systems in shallow soils meeting all other sewage disposal requirements is approved. The following requirements augment this approval, and shall become conditions of the sewage disposal system construction permit:

- The sewage disposal system shall be a Pressure Dose Advantex System with UV Treatment approved by the department. A copy of the Annual Maintenance and Monitoring contract shall be submitted for system final.*
- The sewage disposal system shall be installed in accordance with the design requirements.*
- An approved Certified System Service Provider shall perform the maintenance and monitoring inspections.*
- The Design Consultant shall inspect and certify that the sewage disposal system installation meets their design requirements.*
- The Department finds that the project is exempt from environmental review pursuant to Section 15061(b)(3) of the California Environmental Quality Act Guidelines, because the septic system installation would not have the potential for causing a significant effect on the environment. A Notice of Exemption (NOE) will not be filed for this project. In the absence of an NOE, the Department's decision may be challenged up to 180 days of this approval.*
- Applicant Advisory: The applicant may proceed at their own risk. The Department notes that legal challenges, if any, must be filed within the 180-day statute of limitations.*

Please note that any Department decision can be appealed. The appeal is initially routed through the Department to the Sewage Disposal Technical Advisory Group. The decision by the Sewage Disposal Technical Advisory Group may be appealed to the Board of Supervisors.

An appeal application form is available from the Department. The appeal form must be filled out completely and returned to the Department with the appropriate fee within twenty (20) working days of the date of the decision.

Respectfully,



Environmental Health Director, Amy Irani-Leaverton

JOB COPY



PO Box 975
815 Idaho-Maryland Rd.
Grass Valley CA 95945

"Your Septic System Specialist"
⁵³⁰ 273-2964
⁵³⁰ 885-6066
⁹¹⁶ 652-7665
www.navo.com

Advantex Pretreatment with On Demand Pressure Dose Design

April, 27, 2026

To: Nevada County Health & Human Services
950 Maidu Ave
Nevada City, CA 95959

Reference: 13668 Auburn Rd Grass Valley, CA 95949 APN: 023-010-001

This design is used to apply for the installation permit with the County and get an estimated install price from your desired installer.

Project Details: Soil testing evaluation (results attached) were performed on 02/27/2025 by: Navo & Sons.

Calculations

This site is suited for a "**Advantex Pretreatment with On Demand Pressure Dose**" sewage disposal system around soil test pits SM2 & SM3.

The average percolation rate around these soil test pits is 186 mpi. (see percolation data page)

Application rate = $5 / \sqrt{186} = 0.37 \text{ gal / ft}^2 / \text{day}$

80 gal per person / day / 0.37 gal / ft² / day = 216 ft²

216 ft² / 3 ft² / L.F. = 72 L.F. of "**Pressure Dose**" leach line / person

Installation/ Design Details:

"Advantex Pretreatment with On Demand Pressure Dose" for: 5 people*

(Minimum footage required) as shown on the approved site plan*: 360 LF (395 LF recommended)

Depth of Trench *LEVEL ON COUNTOUR: 42" Width of Trench: 36"

Minimum Trench separation: **7-feet on center**

Minimum required septic/Recirculation tank size: 1500 gallons septic & 1500 gallons recirc tank

Minimum required discharge (pump) tank size: 1500 gallons

(See "Advantex/Pressure Dose Installation Guidelines" for installation details)

**See attached supplemental information.

Use this design to apply for the permit for installation and/or get an accurate installation price. If desired to have our installation division work up an installation, please contact our office.

Marc Lindbloom, REHS #6884

JOB COPY

***Supplemental Information*

The sewage flows for the existing 5 bedroom house have been projected at 80 gallons per occupant. This is the flow rate for a boarding house with one occupant per bedroom as suggested by Nevada County. Therefore, the septic system will be sized for a total sewage flow rate of 400 gallons per day.

The existing septic tank is to be pumped and destroyed by backfilling with earth or gravel.

The existing leach field is to be abandoned

A variance must be obtained from the Nevada County Environmental Health Department. Results indicate the effective soil depth below the proposed leach trench depth will range from 12" to 30". The variance will allow the reduction of the required 24" effective soil depth below the trenches to as shallow as 12".

This is a very difficult site characterized by poor soils. The site conditions do not meet the minimum County standards. Therefore, this proposed septic system will be a "non-conforming" system and, as such, we make no guarantee as to the length of time that satisfactory service will occur.

A 30" deep x 12" wide curtain drain is to be installed upslope from the proposed leach field to divert potential subsurface sheetflow. A berm placed on the downslope side of the curtain drain (see detail drawing) will also divert surface water draining from driveway.

The 100% repair area will need to be located in the same area as the proposed leach field. This repair area can be designated as only suitable for a pretreatment system with drip disposal. The drip lines will be installed 6" deep, over the top of proposed leach trenches. This repair will also require a variance from Nevada County, should it ever be needed.*

**No variance acceptance is guaranteed or implied.*

JOB COPY

Percolation Data Sheet

13668 Auburn Rd Grass Valley, CA 95949 APN: 023-010-001

	(P1)			(P2)			(P3)		
	Interval	Depth: 30"	Drop	Interval	Depth: 32"	Drop	Interval	Depth 36"	Drop
1	0	32.63	0	0	35.00	0	0	34.88	0
2	10	32.63	0	10	34.88	0.13	10	35.25	+0.38
3	30	32.750	0.13	30	35.25	+0.38	30	36.25	+1.00
4	30	32.63	0.13	30	34.88	0.38	30	35.25	1.00
5									
6									
7									
8									
Perc Rate (MPI)		240 ✓		Perc Rate (MPI)		80 ✓	Perc Rate (MPI)		30 ✓
Average Perc Rate using correction factor 1.59 = 186 mpi ✓									

(r) = Percolation test holes are refilled between each reading

Test Date: 02/27/2025
Test Conducted By: Cory Pavan

These percolation tests were performed under the guidelines set forth in County Sewage Disposal Technical Regulations. The statements made above are true and testing was conducted under the supervision of an Environmental Health Specialist.



JOB COPY

Parent Rock Type: V G (MS) A Other Consultant: DR

ES Carver

SOIL PIT# 1 1st HORIZON Depth: 0 to 10
Slope: 7% Aspect: SW
Texture: s ls sl sc scl l c cl sic sicl sil si DRX IWRX MWRX DG
Rock Fragments: gravel 2% cobble 3% stone 3%
Color: 2.5 yr 3D
Redoxymorphic Features: none few common many
RC color RD color RM color
Structure: gran platy block prism f m c single grain massive
Soil Pores: none few common many f m c inters tubular
Moist Consistence: l vfr fr f vf ef
Plasticity: np sp mp vp Stickiness: ns ss ms vs
Roots: none few common many vf f m c
Boundary: Distinctness: a c g d Topography: s w i b
Moisture: dry moist wet saturated
NOTES:

SOIL PIT# 2 1st HORIZON Depth: 0 to 10
Slope: % Aspect:
Texture: s ls sl sc scl l c cl sic sicl sil si DRX IWRX MWRX DG
Rock Fragments: gravel % cobble % stone %
Color:
Redoxymorphic Features: none few common many
RC color RD color RM color
Structure: gran platy block prism f m c single grain massive
Soil Pores: none few common many f m c inters tubular
Moist Consistence: l vfr fr f vf ef
Plasticity: np sp mp vp Stickiness: ns ss ms vs
Roots: none few common many vf f m c
Boundary: Distinctness: a c g d Topography: s w i b
Moisture: dry moist wet saturated
NOTES:

Same as SOIL PIT # , Horizon #

Same as SOIL PIT # 1, Horizon #

2nd HORIZON Depth: 10 to 22
Texture: s ls sl sc scl l c cl sic sicl sil si DRX IWRX MWRX DG
Rock Fragments: gravel % cobble % stone %
Color: 7.5 yr 5T4
Redoxymorphic Features: none few common many
RC color 7.5 yr 6/1 RD color RM color
Structure: gran platy block prism f m c single grain massive
Soil Pores: none few common many f m c inters tubular
Moist Consistence: l vfr fr f vf ef
Plasticity: np sp mp vp Stickiness: ns ss ms vs
Roots: none few common many vf f m c
Boundary: Distinctness: a c g d Topography: s w i b
Moisture: dry moist wet saturated
NOTES: Heavy clay

2nd HORIZON Depth: 10 to 38
Texture: s ls sl sc scl l c cl sic sicl sil si DRX IWRX MWRX DG
Rock Fragments: gravel % cobble % stone %
Color:
Redoxymorphic Features: none few common many
RC color RD color RM color
Structure: gran platy block prism f m c single grain massive
Soil Pores: none few common many f m c inters tubular
Moist Consistence: l vfr fr f vf ef
Plasticity: np sp mp vp Stickiness: ns ss ms vs
Roots: none few common many vf f m c
Boundary: Distinctness: a c g d Topography: s w i b
Moisture: dry moist wet saturated
NOTES:

Same as SOIL PIT # , Horizon #

Same as SOIL PIT # 1, Horizon # 2

3rd HORIZON Depth: 22 to 103
Texture: s ls sl sc scl l c cl sic sicl sil si DRX IWRX MWRX DG
Rock Fragments: gravel % cobble % stone %
Color: 10 7.5 yr 7/1
Redoxymorphic Features: none few common many
RC color RD color RM color
Structure: gran platy block prism f m c single grain massive
Soil Pores: none few common many f m c inters tubular
Moist Consistence: l vfr fr f vf ef
Plasticity: np sp mp vp Stickiness: ns ss ms vs
Roots: none few common many vf f m c
Boundary: Distinctness: a c g d Topography: s w i b
Moisture: dry moist wet saturated
NOTES:

3rd HORIZON Depth: 38 to 57
Texture: s ls sl sc scl l c cl sic sicl sil si DRX IWRX MWRX DG
Rock Fragments: gravel % cobble % stone %
Color: 10 yr 3/1
Redoxymorphic Features: none few common many
RC color RD color RM color
Structure: gran platy block prism f m c single grain massive
Soil Pores: none few common many f m c inters tubular
Moist Consistence: l vfr fr f vf ef
Plasticity: np sp mp vp Stickiness: ns ss ms vs
Roots: none few common many vf f m c
Boundary: Distinctness: a c g d Topography: s w i b
Moisture: dry moist wet saturated
NOTES:

Same as SOIL PIT # , Horizon #

Same as SOIL PIT # , Horizon #

4th HORIZON Depth: to
Texture: s ls sl sc scl l c cl sic sicl sil si DRX IWRX MWRX DG
Rock Fragments: gravel % cobble % stone %
Color:
Redoxymorphic Features: none few common many
RC color RD color RM color
Structure: gran platy block prism f m c single grain massive
Soil Pores: none few common many f m c inters tubular
Moist Consistence: l vfr fr f vf ef
Plasticity: np sp mp vp Stickiness: ns ss ms vs
Roots: none few common many vf f m c
Boundary: Distinctness: a c g d Topography: s w i b
Moisture: dry moist wet saturated
NOTES:

4th HORIZON Depth: to
Texture: s ls sl sc scl l c cl sic sicl sil si DRX IWRX MWRX DG
Rock Fragments: gravel % cobble % stone %
Color:
Redoxymorphic Features: none few common many
RC color RD color RM color
Structure: gran platy block prism f m c single grain massive
Soil Pores: none few common many f m c inters tubular
Moist Consistence: l vfr fr f vf ef
Plasticity: np sp mp vp Stickiness: ns ss ms vs
Roots: none few common many vf f m c
Boundary: Distinctness: a c g d Topography: s w i b
Moisture: dry moist wet saturated
NOTES:

Same as SOIL PIT # , Horizon #
Effective Soil Depth: Groundwater

Same as SOIL PIT # , Horizon #
Effective Soil Depth: Groundwater

Consultant Signature

APN 023-010-1001 JOB # EHZ5-0023

Nevada County Staff Signature

Notes:

29 34



Nevada County Soils Testing Mantle Logs

Permit No. EH 25-0023 APN: 023-010701 Date: 2-27-25 Site Address: 13668 Avenue Rd.

Consultant: [Signature] Nevada County Representative: Corie

Soil Mantle # 3 Slope: 7 % Aspect: SW
1st HORIZON Depth: 3 to 10
 Texture: s ls sl sc scl | c cl sic sicl sil si DRX IWRX MWRX DG
 Rock Fragments: gravel _____% cobble _____% stone _____%
 Color: _____
 Redoximorphic Features: none few common many
 RC Color _____ RD Color _____ RM Color _____
 Structure: granular platy blocky prism f m c single grain massive
 Soil Pores: none few common many f m c inters tubular
 Moisture: Dry moist wet saturated Consistency: l vfr fr f vf ef
 Plasticity: no sp mp vp Stickiness: ns ss ms vs
 Roots: none few common many vf f m c
 Boundary / Distinctness: a c g d Topography: s w i b
 Notes: _____
 Same as SOIL MANTLE # 1, Horizon # 1

Soil Mantle # _____ Slope: _____ % Aspect: _____
1st HORIZON Depth: _____ to _____
 Texture: s ls sl sc scl | c cl sic sicl sil si DRX IWRX MWRX DG
 Rock Fragments: gravel _____% cobble _____% stone _____%
 Color: _____
 Redoximorphic Features: none few common many
 RC Color _____ RD Color _____ RM Color _____
 Structure: granular platy blocky prism f m c single grain massive
 Soil Pores: none few common many f m c inters tubular
 Moisture: Dry moist wet saturated Consistency: l vfr fr f vf ef
 Plasticity: no sp mp vp Stickiness: ns ss ms vs
 Roots: none few common many vf f m c
 Boundary / Distinctness: a c g d Topography: s w i b
 Notes: _____
 Same as SOIL MANTLE # _____, Horizon # _____

2nd HORIZON Depth: 10 to 22
 Texture: s ls sl sc scl | c cl sic sicl sil si DRX IWRX MWRX DG
 Rock Fragments: gravel _____% cobble _____% stone _____%
 Color: _____
 Redoximorphic Features: none few common many
 RC Color _____ RD Color _____ RM Color _____
 Structure: granular platy blocky prism f m c single grain massive
 Soil Pores: none few common many f m c inters tubular
 Moisture: Dry moist wet saturated Consistency: l vfr fr f vf ef
 Plasticity: no sp mp vp Stickiness: ns ss ms vs
 Roots: none few common many vf f m c
 Boundary / Distinctness: a c g d Topography: s w i b
 Notes: _____
 Same as SOIL MANTLE # 1, Horizon # 2

2nd HORIZON Depth: _____ to _____
 Texture: s ls sl sc scl | c cl sic sicl sil si DRX IWRX MWRX DG
 Rock Fragments: gravel _____% cobble _____% stone _____%
 Color: _____
 Redoximorphic Features: none few common many
 RC Color _____ RD Color _____ RM Color _____
 Structure: granular platy blocky prism f m c single grain massive
 Soil Pores: none few common many f m c inters tubular
 Moisture: Dry moist wet saturated Consistency: l vfr fr f vf ef
 Plasticity: no sp mp vp Stickiness: ns ss ms vs
 Roots: none few common many vf f m c
 Boundary / Distinctness: a c g d Topography: s w i b
 Notes: _____
 Same as SOIL MANTLE # _____, Horizon # _____

3rd HORIZON Depth: 22 to 78
 Texture: s ls sl sc scl | c cl sic sicl sil si DRX IWRX MWRX DG
 Rock Fragments: gravel _____% cobble _____% stone _____%
 Color: _____
 Redoximorphic Features: none few common many
 RC Color _____ RD Color _____ RM Color _____
 Structure: granular platy blocky prism f m c single grain massive
 Soil Pores: none few common many f m c inters tubular
 Moisture: Dry moist wet saturated Consistency: l vfr fr f vf ef
 Plasticity: no sp mp vp Stickiness: ns ss ms vs
 Roots: none few common many vf f m c
 Boundary / Distinctness: a c g d Topography: s w i b
 Notes: _____
 Same as SOIL MANTLE # 1, Horizon # 3

3rd HORIZON Depth: _____ to _____
 Texture: s ls sl sc scl | c cl sic sicl sil si DRX IWRX MWRX DG
 Rock Fragments: gravel _____% cobble _____% stone _____%
 Color: _____
 Redoximorphic Features: none few common many
 RC Color _____ RD Color _____ RM Color _____
 Structure: granular platy blocky prism f m c single grain massive
 Soil Pores: none few common many f m c inters tubular
 Moisture: Dry moist wet saturated Consistency: l vfr fr f vf ef
 Plasticity: no sp mp vp Stickiness: ns ss ms vs
 Roots: none few common many vf f m c
 Boundary / Distinctness: a c g d Topography: s w i b
 Notes: _____
 Same as SOIL MANTLE # _____, Horizon # _____

4th HORIZON Depth: _____ to _____
 Texture: s ls sl sc scl | c cl sic sicl sil si DRX IWRX MWRX DG
 Rock Fragments: gravel _____% cobble _____% stone _____%
 Color: _____
 Redoximorphic Features: none few common many
 RC Color _____ RD Color _____ RM Color _____
 Structure: granular platy blocky prism f m c single grain massive
 Soil Pores: none few common many f m c inters tubular
 Moisture: Dry moist wet saturated Consistency: l vfr fr f vf ef
 Plasticity: no sp mp vp Stickiness: ns ss ms vs
 Roots: none few common many vf f m c
 Boundary / Distinctness: a c g d Topography: s w i b
 Notes: _____
 Same as SOIL MANTLE # _____, Horizon # _____

4th HORIZON Depth: _____ to _____
 Texture: s ls sl sc scl | c cl sic sicl sil si DRX IWRX MWRX DG
 Rock Fragments: gravel _____% cobble _____% stone _____%
 Color: _____
 Redoximorphic Features: none few common many
 RC Color _____ RD Color _____ RM Color _____
 Structure: granular platy blocky prism f m c single grain massive
 Soil Pores: none few common many f m c inters tubular
 Moisture: Dry moist wet saturated Consistency: l vfr fr f vf ef
 Plasticity: no sp mp vp Stickiness: ns ss ms vs
 Roots: none few common many vf f m c
 Boundary / Distinctness: a c g d Topography: s w i b
 Notes: _____
 Same as SOIL MANTLE # _____, Horizon # _____

Effective Soil Depth : _____ Groundwater: NO YES @ depth: _____

Effective Soil Depth : _____ Groundwater: NO YES @ depth: _____

Nevada County Representative Signature

Consultant Signature

Effect Below 22" to 78"

JOB COPY



A.P.N.: 023-010-001

SCALE: 1" = 50'

SM = SOIL MANTLE

NG = UNSUITABLE SOIL MANTLE

P- = PERC. TEST

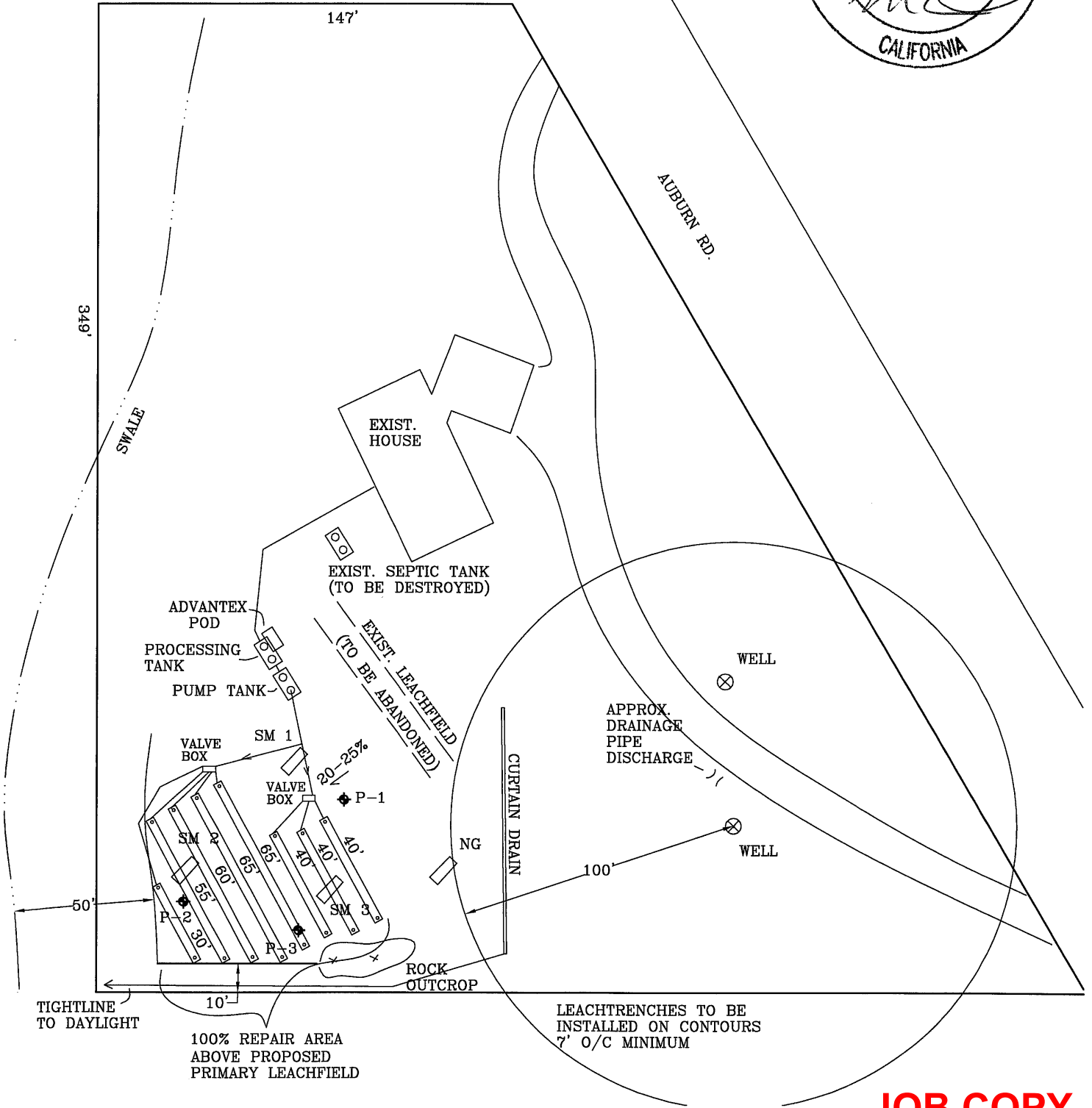

JOB COPY

Special Requirements For Advantex Filter Systems

1. This Advantex System must be installed by an Advantex manufacturer approved installer familiar with installing this type of system in this County. This septic system should be installed by a licensed contractor (Sanitation Systems C-42) or (General A).
2. This system requires a **Vericom Telemetry Control Panel, which needs a phone line (or internet) connection for remote telemetry as required by County Ordinance.** Please note: it does not require a dedicated phone line service.
3. This system requires annual maintenance and monitoring. **The owner must register this system with the County Environmental Health Department and contract with an Orenco certified and County approved "Certified Service Provider" for lifetime Monitoring & Maintenance.**
4. Your Certified Service Provider will be required to be at the final installation inspection, to make sure the system is programmed to my design and that it is operating normally.
5. This system requires a water supply for this site to have a pH between 6 and 8.
6. This report is not a construction permit. A permit to install this system must be obtained from the Department of Environmental Health.

This system has been designed in accordance with the latest industry recognized design standards and County code guidelines. However, the state of the art of sewage disposal design is such that no guarantee can be made as to the length of time that satisfactory service will occur.

Advantex Design

This Advantex design utilizes two AX20 model Advantex Filter Pods which are designed to handle up to 1000-gallons per day of effluent flow. The actual daily flow rate should be approximately 50% of the peak flow rate. For this design a flow rate of 400 gallons will be used. As part of the annual required maintenance, your Certified Service Provider will determine the actual flow rate so the recirculation ratio can be properly maintained.

Design sewage flows: (80 gal/bedroom/day x 5 bedrooms)	400 gallons/day
Actual Flow Rate: (estimated)	400 gallons/day
Recirculation ratio: (the ratio that every unit of effluent moves through the filter)	4 : 1
Volume pumped per day: (400 gals / day x 4 (ratio))	1600 gallons/day
Pump run time: (1600 gals / day / 58.5 gals/min)	27.3 minutes/day
Dose Frequency:	72 cycles/day
Advantex dose time per cycle:	.3 minutes on
Time between doses:	20 minutes off
Volume per dose:	22 gallons
Override dose time per cycle:	.3 minutes on
Override time between doses:	10 minutes off

JOB COPY

Advantex Pod Pressure Distribution Design

Please Note: All pipes and fittings to be Scheduled 40 PVC unless otherwise noted

Design hydraulic head:	5 foot
Distribution lateral size:	1" diameter
Number of laterals per pod:	5
Length of Lateral:	7-feet
Hole size in lateral:	1/8-inch diameter
Holes per lateral:	13 to 14
Total Holes:	136
Holes per pod:	68
Discharge rate per hole:	.43 gals / minute
Discharge rate:	58.5 gals / minute
Dose volume:	22 gals
Pressure line from Recirc Tank size:	2" diameter

JOB COPY

Advantex Hydraulic Calculations

Gallons per dose:	22 gallons
Doses Per day:	72/day
Pump Flow Rate:	58.5 gallons per minute

Head Loss Calculations

Elevation from recirc-tank to filter pod:	0 +/- feet
Pump level in tank:	5 +/- feet
Friction loss of 1" pump line: 40' per 100' @ 30 gal/min	1.3 +/-
Friction loss of 1" lateral: 2.69' per 100' @ 6 gal/min	1.3 +/-
Fitting friction loss:	5 +/-
Design head:	5 +/-

Total Head loss: 17.6 +/-

Use Orenco Systems, Inc. P500511, 1/2 hp, 115 volt, sewage effluent pump.
(this is capable of discharging 58 gpm @ 33' head loss with a total head of 60')

JOB COPY

Advantex Pump Curve – PF5005 – Recirc Tank

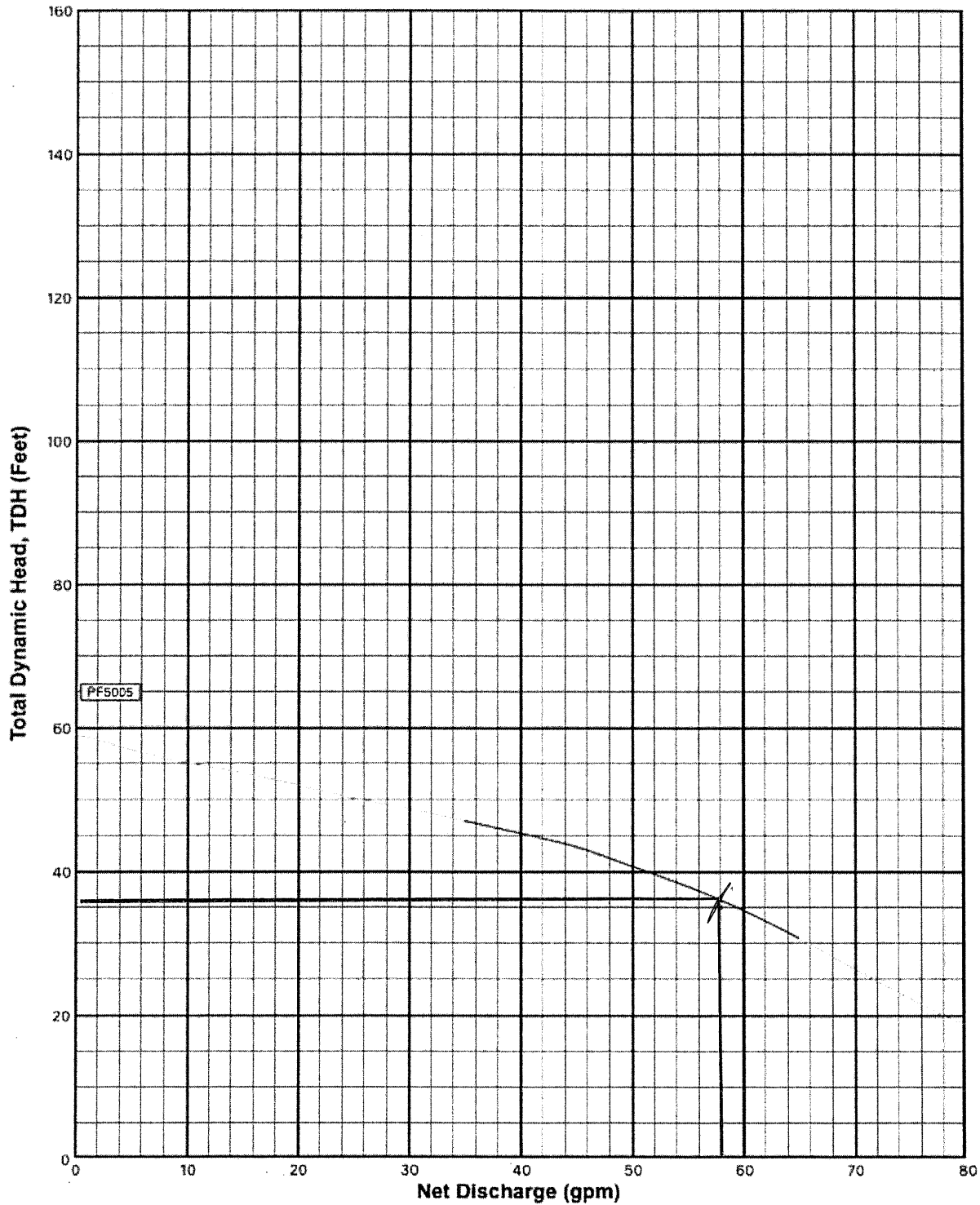

On Demand Pressure Dose Design

Transport line Diameter	=	2-inches
Transport line length	=	70-feet
Manifold diameter	=	1.25-inches
Manifold Length	=	178-feet average
Lateral diameter	=	1- inch
Lateral length	=	395-feet
Lateral hole diameter	=	1/8-inch
Lateral hole spacing	=	6-feet
Discharge rate per hole	=	.433 gallon per minute
# of holes per lateral	=	5-11
Total # of holes	=	65
Discharge rate	=	28 gallons per minute
Dosing volume	=	100 gallons
Doses per day	=	4
Pressure Head	=	5-feet
Duration of Dose	=	*

*Please note: The actual "duration of dose" settings will be set after determining the "pressure up time" at the squirt test.

Pressure Dose Hydraulic Calculations

Head Loss Calculations

Elevation from discharge tank to field:	0 +/- feet
Pump level in tank:	5 +/- feet
Friction loss of 2" pump line:	1.3 +/-
Friction loss of 1 ¼" piping:	0.9 +/-
Friction loss of 1" laterals:	7.6 +/-
Headwork friction loss:	9 +/-
Zone friction loss:	- +/-
Fitting Friction Loss:	2 +/-
Total Head loss:	25.8 +/-

Use Orenco Systems, Inc. PF300511. ½ hp, 115 volt, sewage effluent pump.
(this is capable of discharging 28 gpm @ 65 head loss with a total head of 112')

JOB COPY

Advantex Pump Curve – Pump Tank

Pump Curve
for PF3005

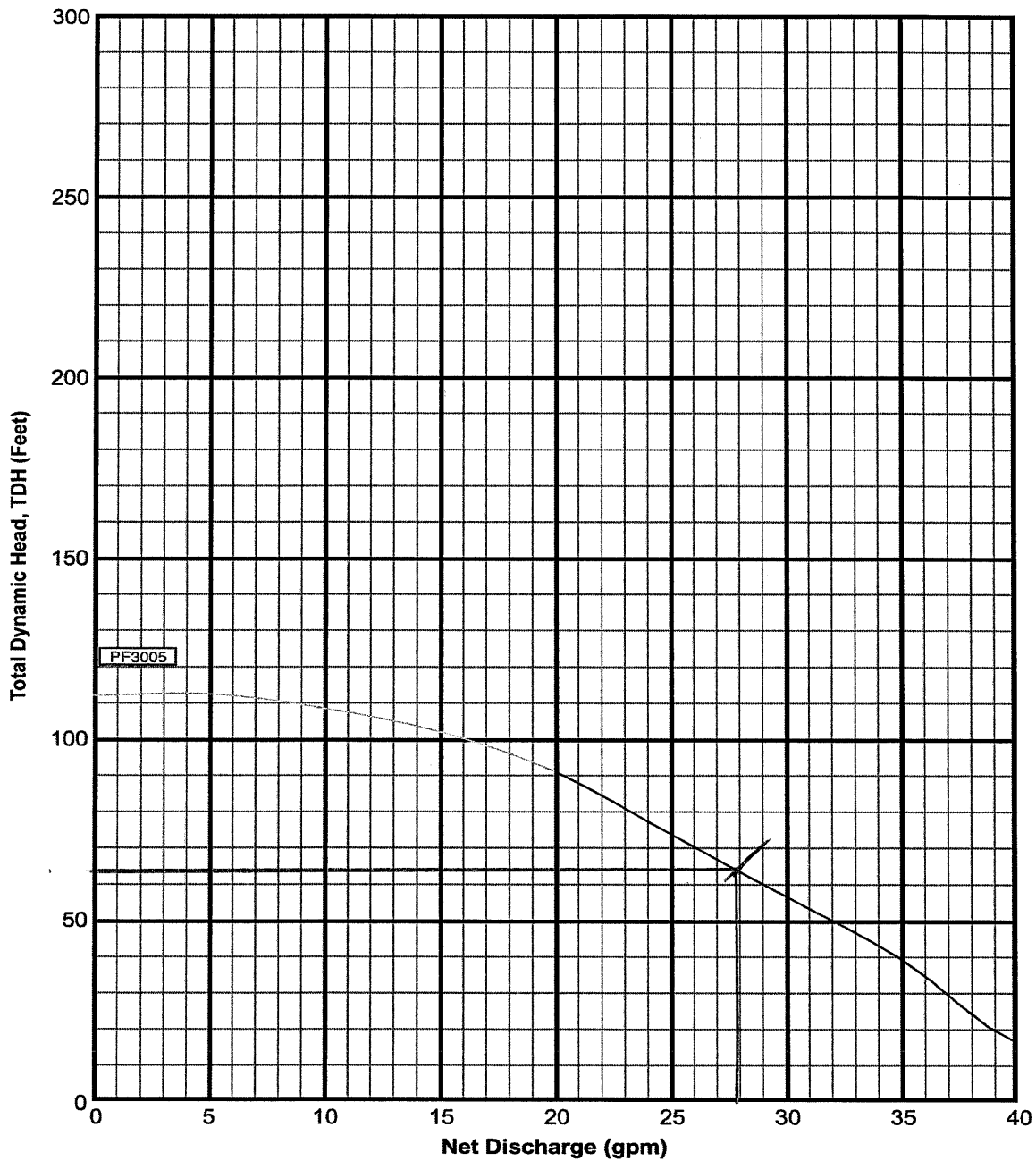

JOB COPY

Site Preparation & Installation

1. Flag all setback requirements prior to construction and maintain flagging for inspection. Maintain all County setbacks.
2. All vegetation shall be removed from the designated leach field area. Be careful to avoid removing/ disturbing the native grade.

Advantex / Pressure Dose System Material Specifications

Septic tank: We recommend installing septic tank with a 4-inch inlet and outlet sanitary tees. (for minimum size requirements see page 1 "Installation/ Design Details")

Septic tank shall be installed with an effluent filter in second chamber of the tank and water-tight risers over each lid as specified in the local sewage ordinance. Risers to extend to the ground surface and be equipped with gas tight, bolt down, and fiberglass lids.

Risers shall be caulked at the septic tank surface in order to be watertight. Minimum diameter of risers to be 24" and shall extend a minimum of 2" beyond the septic tank lids.

Recirculation tank: two compartment, precast concrete as approved by Nevada County. Tank to be fitted with risers as described above.

Pump tank: We recommend installing a single compartment, precast concrete, as approved by the County Environmental Health. (for minimum size requirements see page 1 "Installation/ Design Details") Tank to be fitted with a riser over both lids. The pump vault shall be installed so that removal is easily facilitated for annual cleaning.

Treatment System: Two Advantex AX20, Mode 1B, treatment system pods with OSI Pro Step effluent pumping system

Recirc tank pump: Orenco Systems Inc. effluent pump or equivalent. (see "Advantex Hydraulic Calculations" and "Advantex pump curve" for pump details)

Ultraviolet Disinfection Unit: Use Orenco Systems Inc. UV unit for installation with Advantex system. Model AXUV-125/31

JOB COPY

Pump screen & vault: the pump (in the processing tank) is to be screened using an Orenco Systems Inc. Biotube screened pump vault, Model PVU 68-24-25-NB.

Discharge tank pump: Orenco Systems Inc., sewage effluent pump or equivalent.

Pump housing for pump tank: Use an Orenco Systems Inc. Universal Flow Inducer, Model UFI-4 to house the pump.

Pump discharge assembly: Hose and valve assembly shall include a 1 1/4" diameter high-pressure PVC flexible discharged assembly, Orenco System, Inc. model HV 150 B-AS-X PR or equivalent. Discharge pump line shall have an in-line check valve, threaded union, ball valve, and anti-siphon valve.

Water level and alarm floats: Water level control float switches shall be Orenco Systems, Inc. MF-3v for recirculation tank and pump tank, or equivalent (see pump tank cross-section). Float switch and wires shall be securely attached to a rigid upright riser, so that they will not slip or tangle. A high level alarm float, on / off float, and redundant off / low-level alarm float shall be provided. Pump and alarm shall be on separate electrical circuits.

Control panel: Use Orenco System, Inc., VCOM Advantex AX20BT Control Panel, 115 volt. Which needs a phone line (or internet) connection for remote telemetry as required by County Ordinance. Please note: it does not require a dedicated phone line service.

Air Vent: Use Orenco Systems, Inc. passive air vent assembly.

Leach Field: All absorption trenches should be placed **LEVEL ON CONTOUR** as per *"Installation/ Design Details on page one*. The bottom of the trenches should be level. Each trench shall be separated as specified on *page 1 "Installation/ Design Details*.

If Drain Rock is desired: Please note that 6-inches of 3/4 to 1 1/2-inch, washed drain rock should be placed below a 1-inch pvc pipe (with the perforations placed down) and an additional 2-inches of rock over the pipe for a total of 12-inches of rock in the trench (*see enclosed cross-section drawings*)
(OR if desired an equal amount of Easy-flow drain system can be installed)

JOB COPY

The surface between the soil and drain rock (or Easy-flow) should be covered with a permeable, non-woven geo-textile fabric to prevent migration of overlaying fine grained soils into the drain rock. *(see enclosed pressure dose system cross section)*

The trench should be backfilled with a minimum 12-inch clean, native soil and mounded over each trench to allow for settlement.

Distribution: All piping and fittings to be 1" Schedule 40 PVC, unless otherwise specified. All bends in pump line to be 45 degree elbows (or long sweep electrical conduits) where possible. All piping and fittings also to be solvent welded water tight. Ends of each lateral shall be fitted with a clean-out, clean-out shall be accessible with a riser box extending to finish grade *(see detail)*. *(see enclosed cross-section drawings)*

Filter Fabric: Use Dupont Tytar, or equivalent.

Valve box: Use a polyethylene valve box (minimum 10") with a bolt down cover to house the leach field gate (ball) valves and leach line clean outs / inspection pipes.

Orifice shields: Use Orenco Systems, Inc., or equivalent, Orifice Shields, Model for 1" diameter leach field laterals

Observation Wells: Install the 4" diameter plastic observation well pipes at the end of each trench. Pipe to have 1/8" wide slots from the bottom of rock to top of rock. Pipes to be capped, not glued. *(see enclosed cross-section drawings)*

Electrical Components: There shall be 2 circuits supplied to the pump system; one for the pump and a separate one for the panel. Please refer to local electrical codes for installation of the electrical components. *(see control panel and wiring for more details)*

Advantex Installation Guidelines

1. Flag all setback requirements prior to construction and maintain flagging for inspection. Maintain all County setbacks.
2. Check the site location for proper installation of the processing tank, recirculation tank, Advantex filters, and pump tank. Please Note: the 2-inches diameter outlet coupling for the filtrate return line is permanently installed in one corner of the Advantex pod.
3. Excavate the processing tank, recirculation tank, filter pods, and pump tank hole. Be sure to check for proper elevation between the filter return line and RSV (1/4-inch per foot). If the filter pods are along side the processing tank, excavate the filter pod hole 12-inches wide and longer than the pod dimensions. Provide a minimum 3-inch base of sand or pea gravel under the recirculation tank, and pump tank. If the filter pod is placed on the processing tanks then place 5-inches of sand or soil on top of the tank to allow for the proper slope of the filter return line.
4. Install access risers on the recirculation tank. Align grommets to ensure proper pod installation. Seal riser to the tank. Seal is to be watertight.
5. Install the RSV in the waterside of the recirculation tank, mode 1. The RSV should be installed between the baffle wall and the pump system to help insure mixing of the return effluent. Attach the RSV bracket to the riser. Determine the Stinger pipe length to allow for a 200 - 300 gallon surge volume (see detail). Connect the RSV body to the Stinger pipe. Install the handle in the top of the RSV body and secure with screws. Slide the RSV into the bracket attached to the access riser.
6. Install the 2-inch PVC filtrate return line from the outlet coupling in the bottom of the Advantex filter to the inlet side of the split flow tee - Slope a minimum of 1/4-inch per foot or, for less than a 6-foot long pipe, provide a minimum 2-inch elevation difference. Be sure the 2-inch filtrate return-line is continuously sloped.
7. Install the passive air vent using 2-inch PVC pipe fittings that protrudes through the filter wall. Be sure the vent line is sloped to drain into the textile filter. Do not allow bellies.

8. Install the Bio-tube pumping package into the waterside of the recirculation tank.
9. Attach the electrical splice box inside the access riser. Place the pump and discharge assembly into the flow inducer.
10. Check the float locations for proper setting. The bottom float should be positioned as close to the top of the biotube cartridge as possible. The top float should be set 1-inch to 2-inches below the invert of the tank inlet to allow for a surge volume of 200-300 gallons. See attached detail.
11. Connect the transport line to the pump discharge with 1-inch PVC pipe. Slope the line to drain back into the tank after each cycle. Drill the hole at the desired position with a 1 9/16-inch hole saw. The two possible positions are marked on the outside of the filter pod.
12. Install the electrical control panel to the structure. See wiring diagram for details.
13. Check the connections for watertight seals and proper drainage. Fill the tank with water to a level approximately one inch above the RSV cage. Water should be well above the bottom float. Turn the pump switch to manual. As water begins running through the system, ensure proper drainage through the filter return line and RSV. All or some of the return filtrate flowing to the RSV should be exiting the system through the final discharge line.
14. Carefully backfill the tank excavation and around the filter pod with clean soil. Compact around the filter pod in 12-inch lifts. Slope to allow surface to shed away from the filter and tanks.
15. **System Start Up:** Verify all pump and float operations on both manual and automatic settings. To facilitate quick testing of the automatic operation, temporarily set the programmable timer to short intervals, but no shorter than 15 second on, 15 seconds off. When you check the low level alarm float, the pump is inoperable when the float activates. Verify this by manual operation.

JOB COPY

16. Flush out the filter pod laterals to remove any construction debris. Check orifice squirt, head should be 2-feet or higher.

17. **Setting the programmable timer:** There are two sets of timers to control the pump cycle, Normal setting and Override. The override timer will activate when the high water alarm float is in the up position.

Pressure Dose Installation Guidelines

- 1) If needed fill material to be approved by the design consultant.
- 2) Flag all setbacks prior to construction and maintain flagging for inspections. Maintain all County setbacks.
- 3) Call for a pre-construction meeting with the designer and County.
- 4) Construct the leach trenches level on contour. **(For total trench depth, width and depth of drain rock see trench cross-section).** Trenches shall be a minimum of 10' apart, center to center. Trenches may not be installed during wet weather conditions. Sidewalls to be roughened by raking, if smearing or compaction occurs during construction. Call for an open trench inspection prior to placing drain rock.
- 5) Excavate the 30" deep x 12" wide curtain drain the tight line is to discharge below the leach field.
- 6) Install the 4" diameter plastic observation well pipes at the end to each trench. Pipe to have 1/8" wide slots from the bottom of rock to top of rock. Pipes to be capped, not glued.
- 7) Place all of the drain rock in each trench. Dig a 3" deep furrow in the drain rock down the center of each trench for the distribution laterals. Install the laterals, gate valves, valve box, and clean outs... Drill the 1/8" orifices in the laterals true round and true vertical with a new 1/8" drill bit. Do not ream out the orifices with the drill bit. All orifices to be facing up in a straight line. The first hole is to be 24" in from the start of the drain rock, remainder of holes to be

JOB COPY

4-foot on center. (See *Sample Pressure Dose Layout for details*)

- 8) The contractor, Environmental Health Department, and consultant to pump test the system and adjust ball valves to provide equal distribution to all trenches.
- 9) Place the orifice shields over all orifice and cover laterals with 2" of drain rock (See trench cross-section) and the filter fabric (DuPont Typar, or equivalent) after squirt test is approved.
- 10) Backfill the trenches with clean native earth (See trench cross-section). The gate (or ball) valves to be installed below grade and covered with a 10" minimum valve box. The clean-outs to be tied to the inspection pipe be installed below grade and covered with a 8" minimum valve box.
- 11) Provide water tight riser over pump tank accesses. Risers are to extend 2" above grade level. Riser / tank joining to be water tight. Install an effluent filter at the septic tank outlet tee.
- 12) Leach field area to be seeded with grass and covered with straw. Call for final inspection.

JOB COPY

Advantex Pressure Dose Inspection

In addition to inspections conducted by Environmental Health, the design consultant will conduct inspections of the critical steps of the construction process. Upon completion, the design consultant will certify to the Health Department that the system was installed in accordance to the approved design. Please note: A minimum of 48 hours notice is required for any requested inspections for the designer and your certified service provider. A minimum of 24 hours notice is required by Environmental Health Department Inspections.

1. **Pre-construction** - Prior to arrival the location of the various components of the system are to be marked out by flagging, stakes or paint on-site.
2. **Pressure Dose Field & Advantex Filter Flow/Operation Test** - After the tanks, Advantex pod, field and all plumbing/electrical connections installed. A watertight test is required, it would be done at this time.
3. **Final Inspection/Sign-off** - Your Certified service provider is required to be at this inspection to program and sign off the system. Please note: for final certificate of completion, this system will need to be connected to the Certified Service Provider and calling in.

The above inspections are expected to take up to 1 hour and are included in our original design costs and are at no additional charge. Additional time or inspection will be charged out at our normal inspection rate.

ADVANTEX PODS

Top View
(POSSIBLE CONFIGURATION)

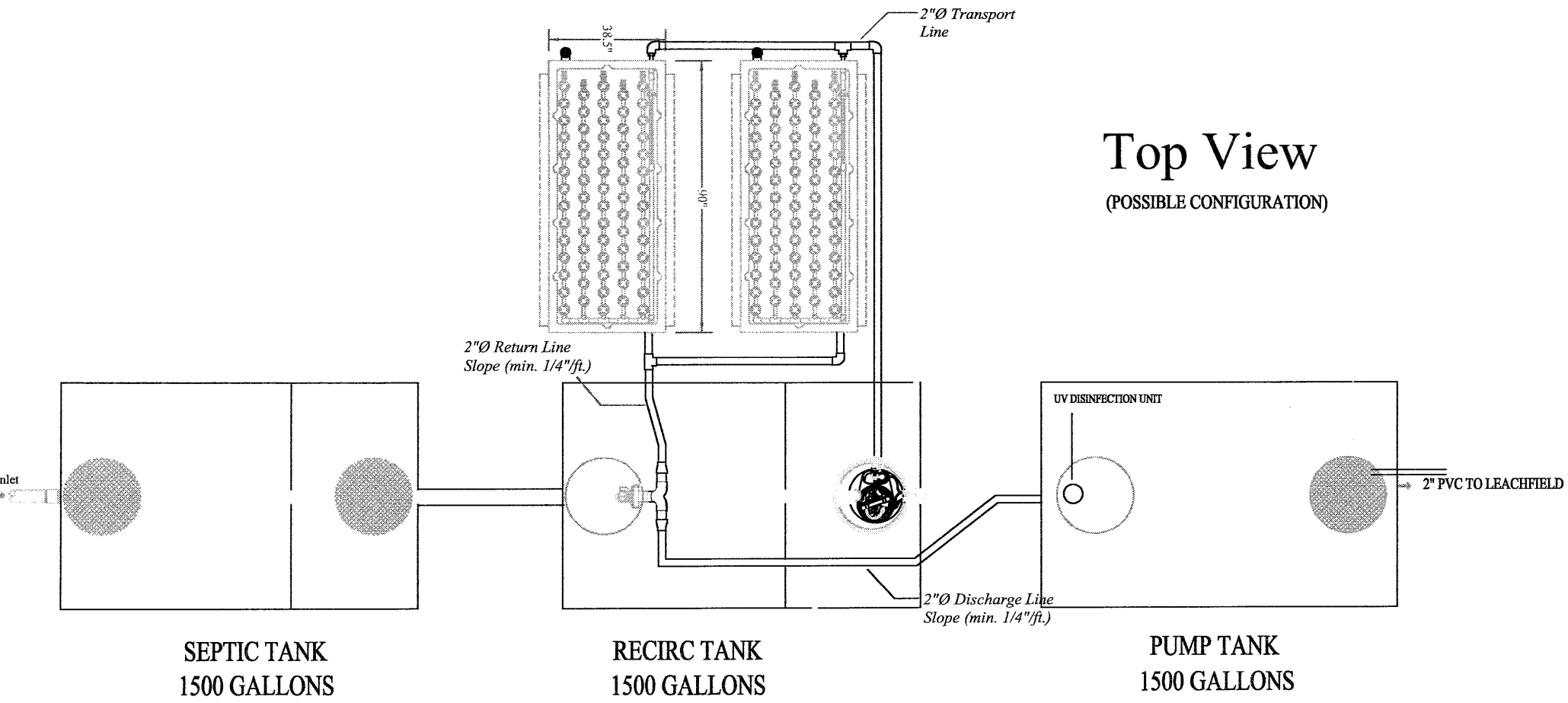

JOB COPY

Project: **RECIRC TANK**
 Manufacturer: (CA) Merrill & Sons 1500 gallon
 System Type: Mode 1 Primarily

Prepared By: Bill Hensley
 Date: Aug 18, 2008



814 AIRWAY AVENUE
 SUTHERLIN, OREGON
 97479

TOLL FREE
 (800) 348-9843

TELEPHONE:
 (541) 453-4449

FACSIMILE:
 (541) 459-2884

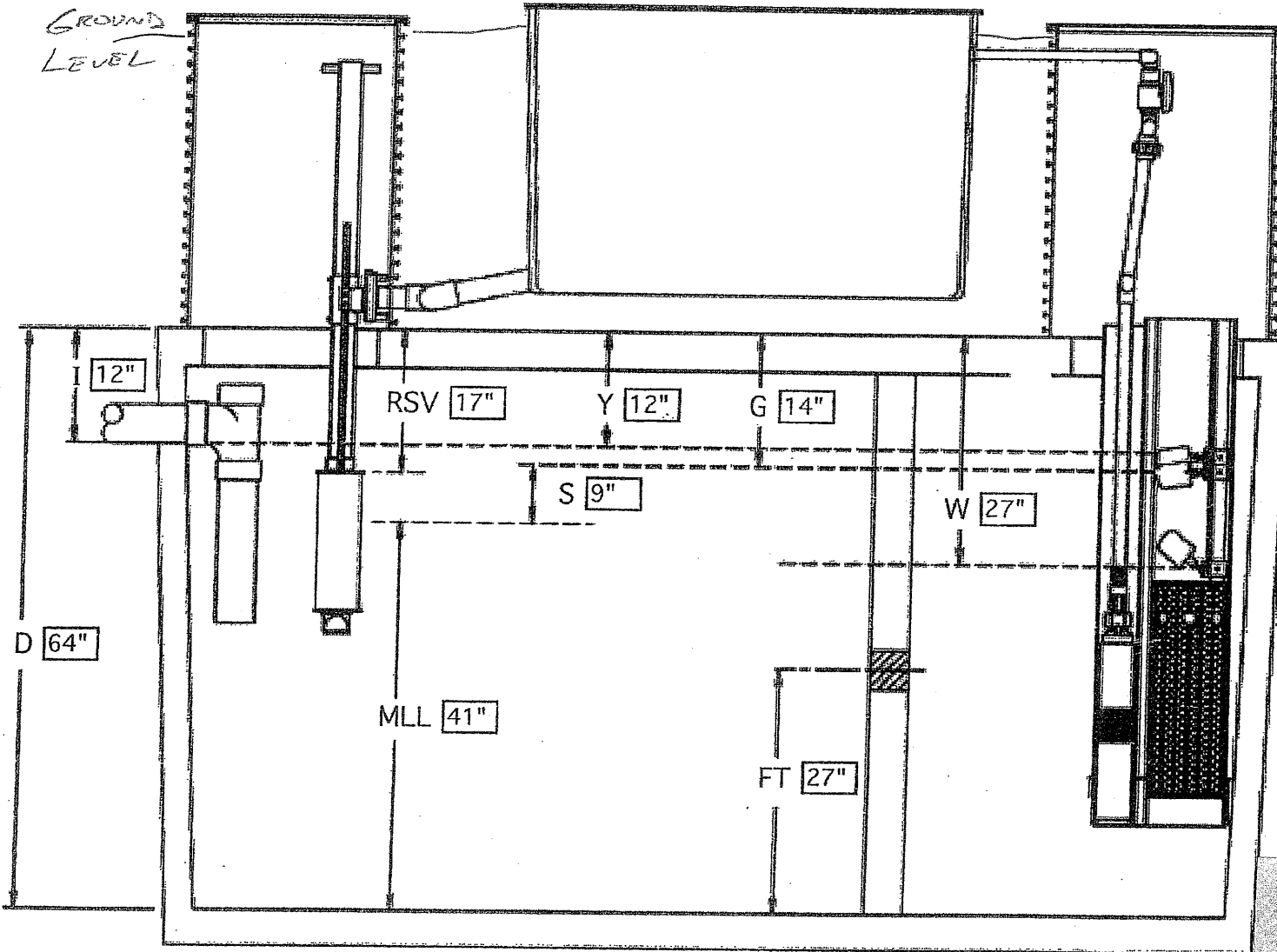

PVW68-2425-NB
[Signature]

Key:			AX20 Timer Settings:		
D: Depth	I: Invert of Inlet	S: Surge Volume	Time On:	15	Sec
FT: Flow Through Port	MLL: Min Liquid Level	W: Redundant Off/Low Water Alarm	Time Off:	19.75	Min
G: Override Timer Level	RSV: RSV Seat Level	Y: High Water Alarm	Override Time Off:	9.88	Min

JOB COPY

PUMP TANK

NOT TO SCALE

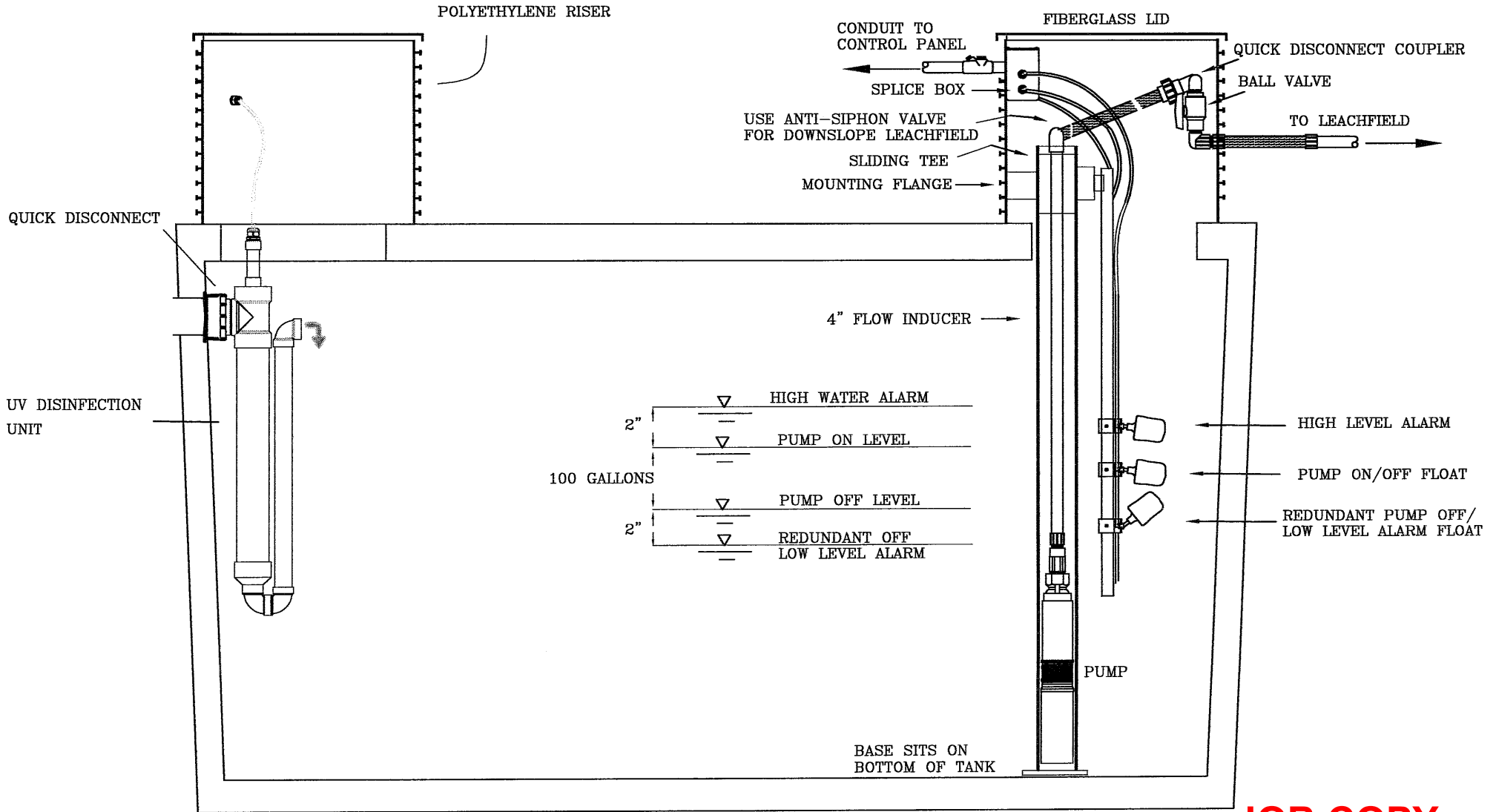

JOB COPY

LEACHFIELD AND VALVE DETAIL

N.T.S.

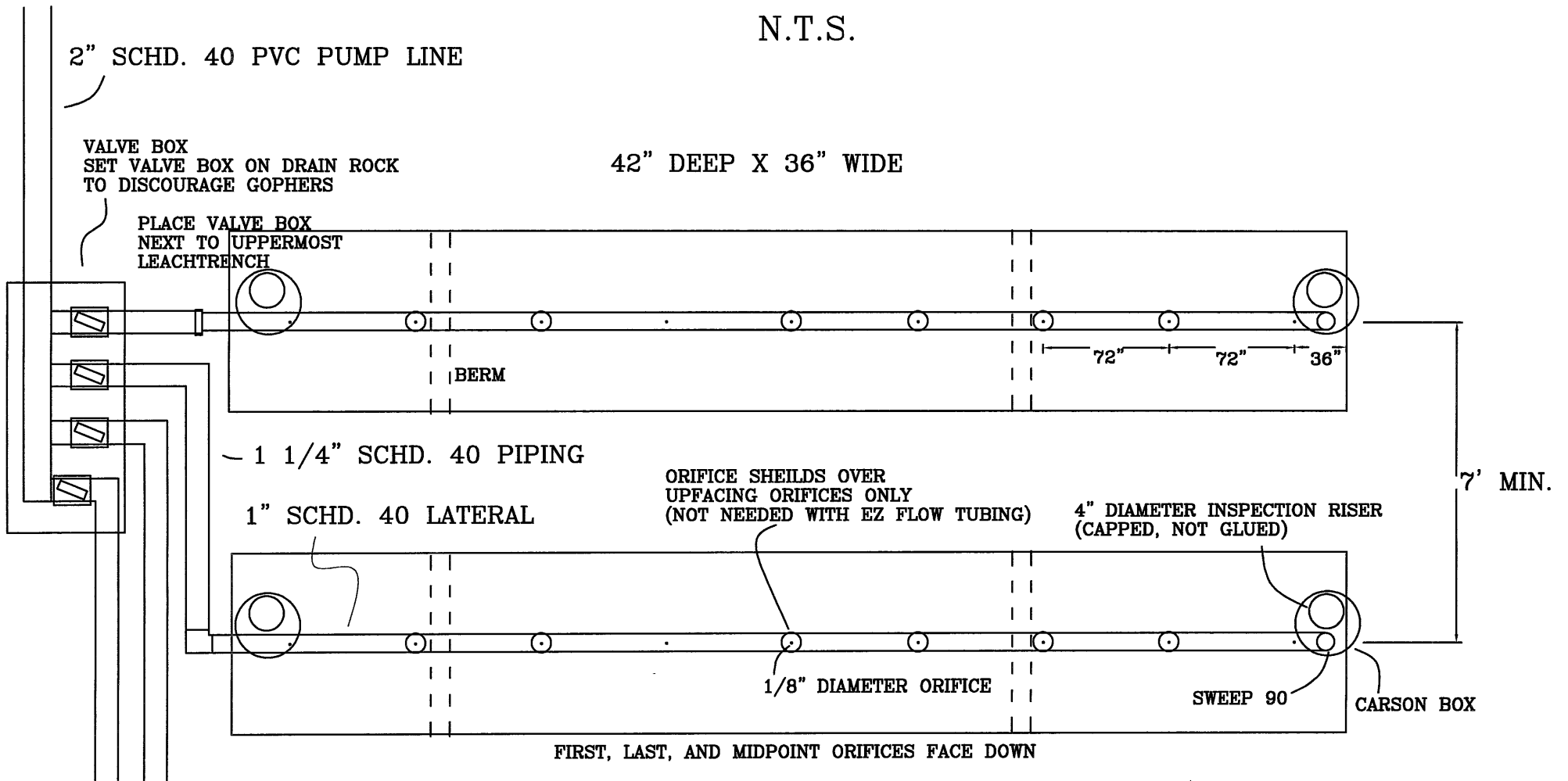

JOB COPY

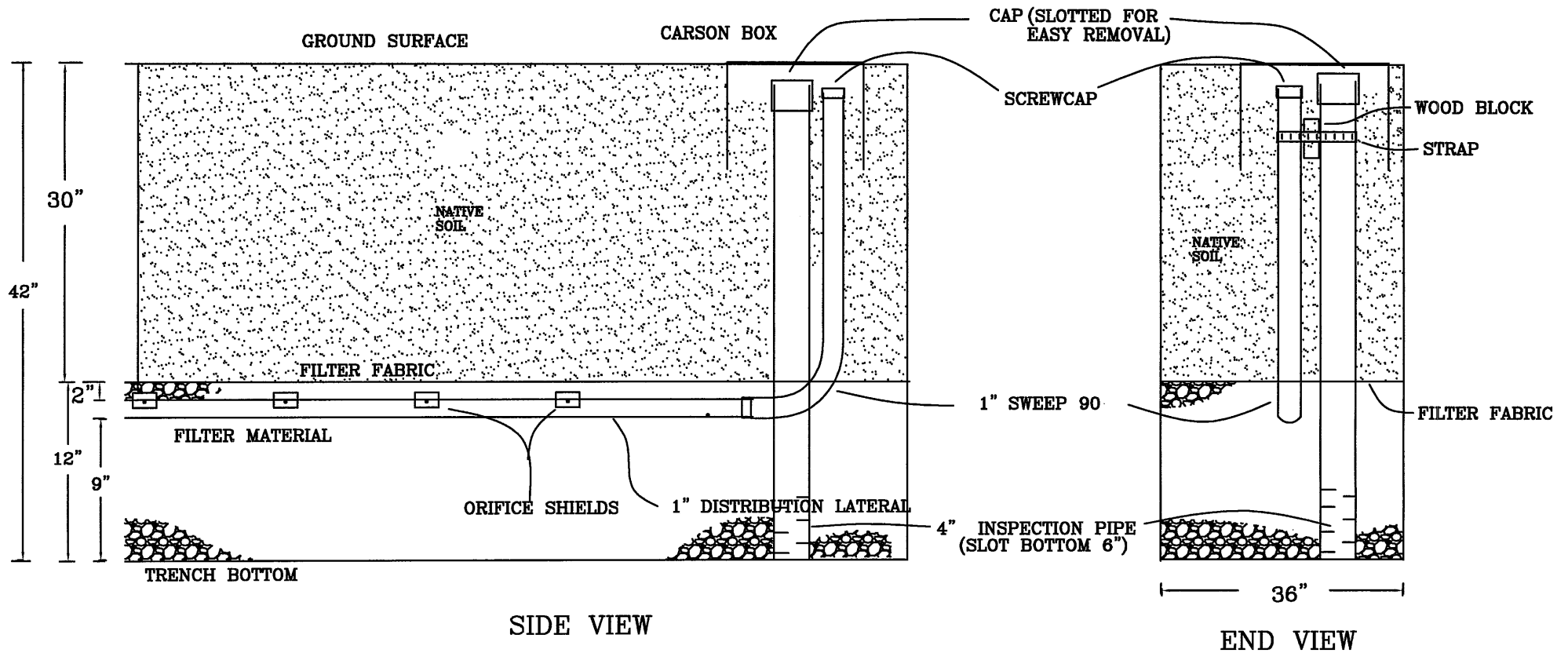

PRESSURE DISTRIBUTION LEACH TRENCH WITH FLUSH RISER
N.T.S.

JOB COPY

CURTAIN DRAIN DETAIL
N.T.S.

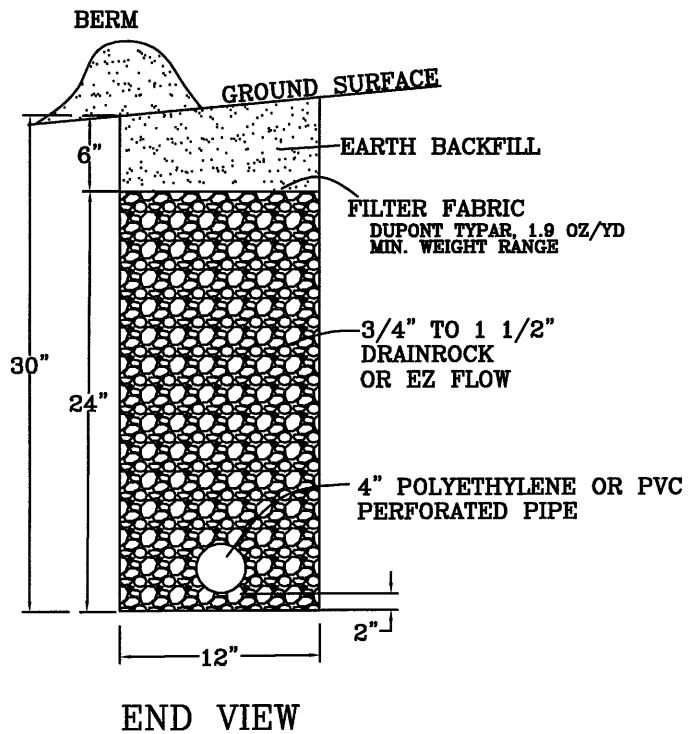

CURTAIN DRAIN DISCHARGE
N.T.S.

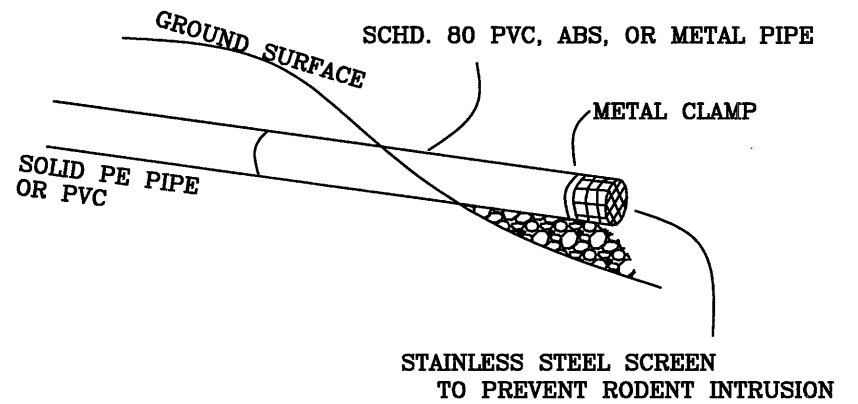

JOB COPY

VeriComm AX20B Control Panel & Wiring Details

Orengo Brand VeriComm Control Panel (please note equivalent panel can be used)

VeriComm AX20B remote telemetry control panels are used in Advantex AX20 Treatment Systems with two pumps for timed recirculation and pump discharge. Coupled with the web-based VeriComm Monitoring System, these affordable control panels give the ability to remotely monitor and control treatment system operation, with realtime efficiency to wastewater system operator and maintenance organizations, while remaining invisible to the homeowner. AX20B panels allow remote operators to change system parameters, including timer settings, from web interface. Interlocked controls prevent recirculation pump operation if there is a high-level alarm on the discharge side. These 60-Hz simplex panels are UL-listed and UL-C listed.

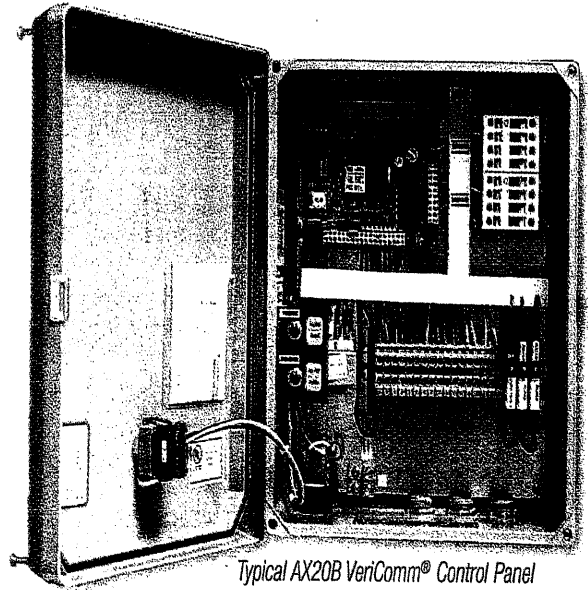

Typical AX20B VeriComm® Control Panel

Standard Models: VCOM AX20B1, VCOM AX20B2

- 120-VAC control circuit breaker
- 120-or 120/240-VAC pump circuit breaker
- Motor-start contactor for pump circuit
- Automatic/Off/Manual (Auto/Off/Man) toggle switch
- 7/8-inc red visible alarm
- 95 dB audible alarm
- Automatic alarm silence reset
- Type 4X (IP 66) rated enclosures
- Pump motors used with these panels require internal overload protection

Status Light Indicators

- Flashing green LED for normal operation
- Yellow LEDs for status of digital inputs
- Red LEDs for status of digital outputs and modem activity

JOB COPY

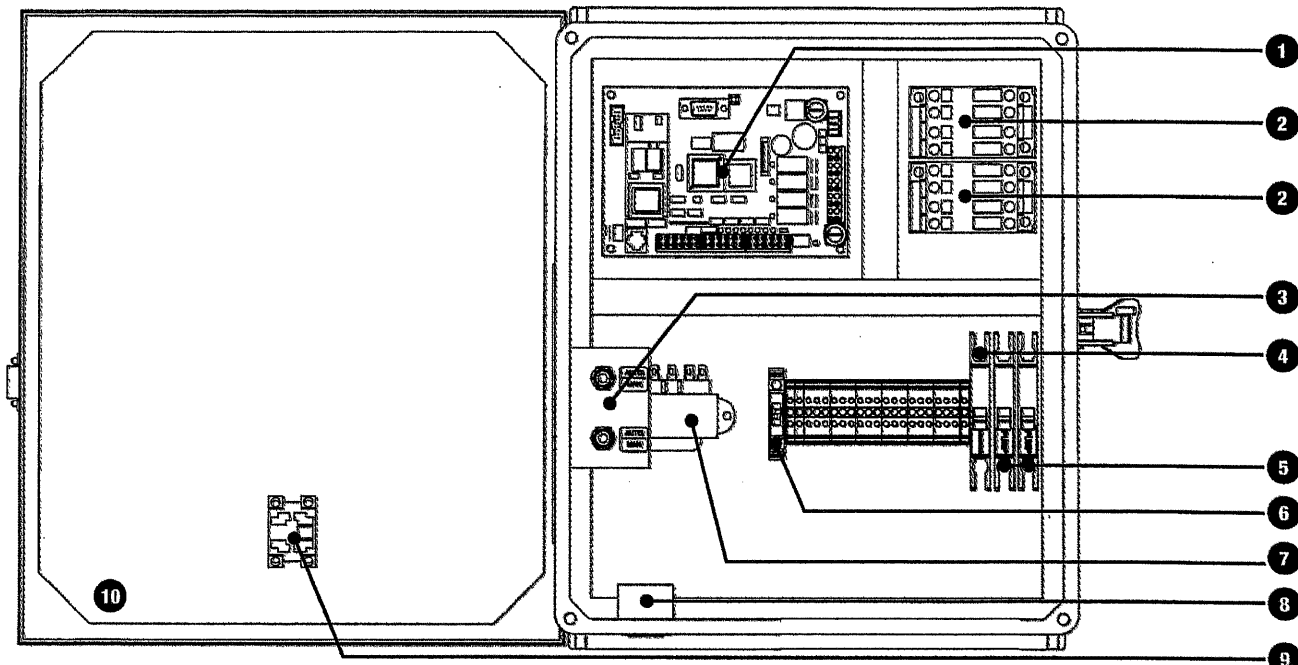

Standard Components

Feature	Specifications
1. VeriComm® Remote Telemetry Unit*	ATRTU-100: 36/18 VAC (center tap transformer); 8 digital inputs, 4 analog inputs, 4 digital outputs, 0 analog outputs, on-board modem (2400 baud); LED input and output indicators; 1-year battery backup of data and program settings
2. Motor-Start Contactors	120 V, 16 FLA, 1 hp (0.75 kW), 60 hz; 2.5 million cycles at FLA (5 million at 50% of FLA) 240 V, 16 FLA, 3 hp (2.24 kW), 60 hz; 2.5 million cycles at FLA (5 million at 50% of FLA)
3. Toggle Switch	Single-pole, single-throw, momentary manual switch; 20 A, 3/4 hp (0.75 kW)
4. Controls Circuit Breaker	10 A, OFF/ON switch; single-pole 120 V; DIN rail mounting with thermal magnetic tripping characteristics (240 V units are available for international markets)
5. Pump Circuit Breaker	20 A, OFF/ON switch; single-pole 120 V or double-pole 240 V; DIN rail mounting with thermal magnetic tripping characteristics
6. Fuse	250 VAC, 1 A
7. Transformer	120 VAC primary, 36 VCT @ 0.85 A secondary
8. Audible Alarm	95 dB at 24 in. (610 mm), warble-tone sound
9. Visual Alarm	7/8-in. (22-mm) diameter red lens; "Push-to-silence;" UL Type 4X rated, 1 W LED light, 120 V
10. Panel Enclosure	Measures 13.51 in. high x 11.29 in. wide x 5.58 in. deep (343 x 287 x 135 mm). UL Type 4X rated. Constructed of UV-resistant fiberglass; hinges and latch are stainless steel.

Recommended Breaker & Wire Size

Pump Motor Size	Breaker Size	Wire Size	Max Distance*
120 VAC 1/2 hp	20 amp	10 AWG	105 ft
240 VAC 1/2 hp	15 amp	14 AWG	161 ft
3/4 hp	20 amp	14 AWG	130 ft
1 hp	20 amp	12 AWG	172 ft
1-1/2 hp	20 amp	12 AWG	126 ft

* This is the maximum distance from this sub-panel to the pump motor for the recommended wire size. Distance is based on 3% maximum voltage drop from sub-panel to load at maximum recognized pump motor amps at 75° C.

JOB COPY

**Control Panel Wiring Diagram
Model VCOM-S1 PTR0**

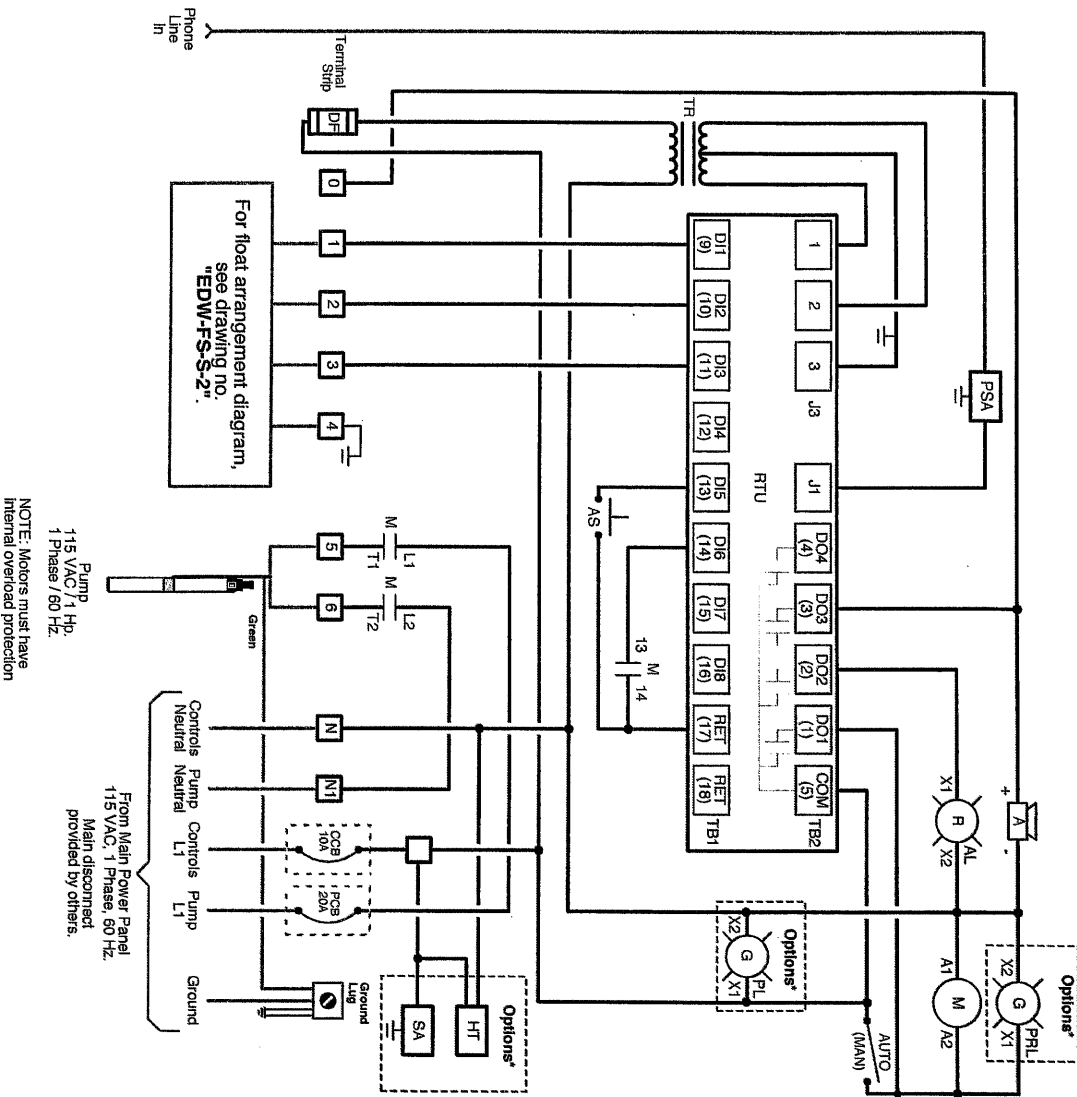

NOTE: Motors must have internal overload protection

115 VAC/1 Hp
1 Phase/ 60 Hz.

From Main Power Panel
115 VAC, 1 Phase, 60 Hz.
Main disconnect
provided by others.

- Key**
- Factory Wire
 - - - Field Wire
 - Alternate Field Wire
 - A1 = Alarm Alarm, 115 VAC
 - AS = Alarm Silence Switch
 - CCB = Control Circuit Breaker
 - DF = Fuse, 120VAC/7A
 - M = Motor Contactor
 - PCB = Pump Circuit Breaker
 - PSA = Phone Line Surge Arrester
 - RTU = ATRTU-100 Controller
 - TL = Terminal Link
 - TH = Transformer 120-36/18VAC
- *Options**
- HT = Heater
 - PRL = Power Run Light
 - SA = Surge Arrester

JOB COPY

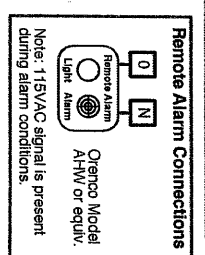
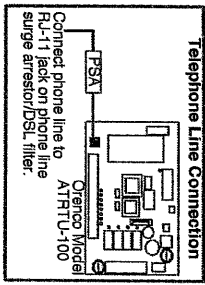
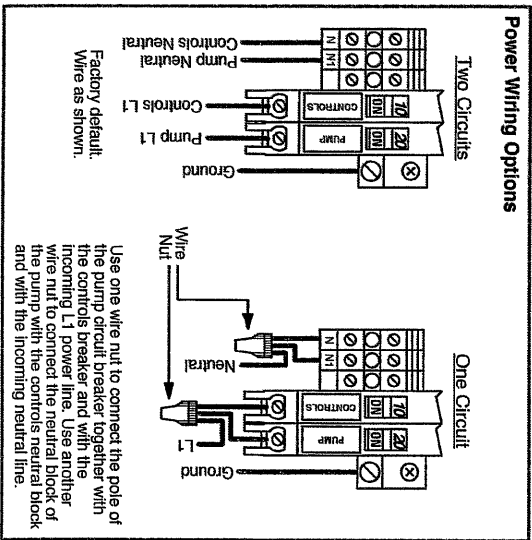

For VCOM-S PTR0 operation description, see drawing no. "EIN-CP-QP-504".

Float & Splice Box Wiring Diagram

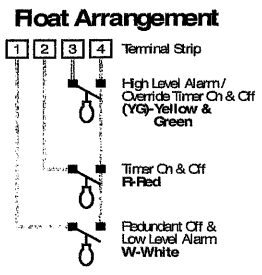

Float Types

Typical Orenco float model: A
Specs: contact - normally open differential - no minimum power rating - signal

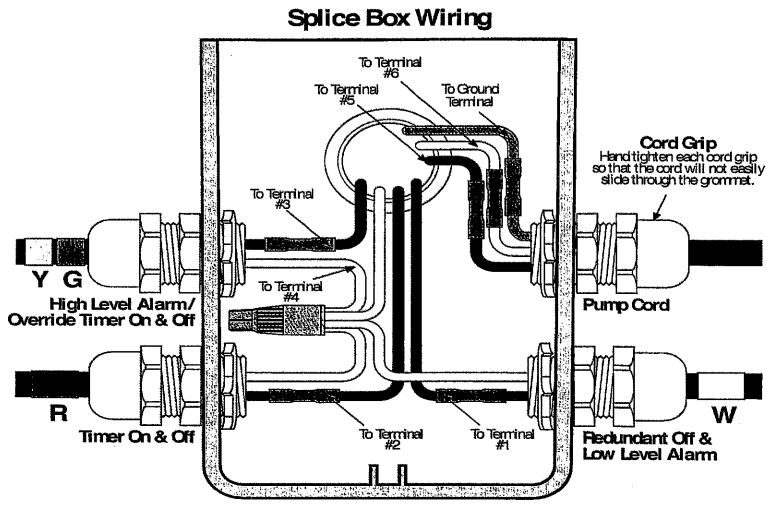

Float Tag Colors

Y - Yellow	R - Red
P - Purple	O - Orange
B - Blue	E - Grey
G - Green	W - White

Note: Multi-function floats will have more than one marker

Attention: Failure to follow splicing instructions will void warranty

* Refer to drawing EIN-SB-SB-1 for splicing instructions.

Key

- Black Wire
- White Wire
- Green Wire
- Waterproof Wire Nut
- Heat Shrink & Butt Connector

Control Panel Series	Float Function Color Code	Splice Box Model	Drawing No.
VCOM-S PTR0	(YG)RW	SB4	EDW-FS-S-2

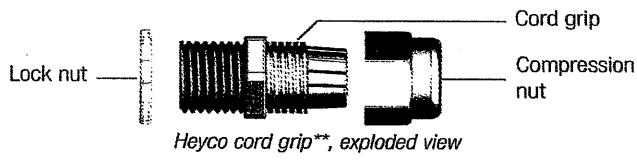
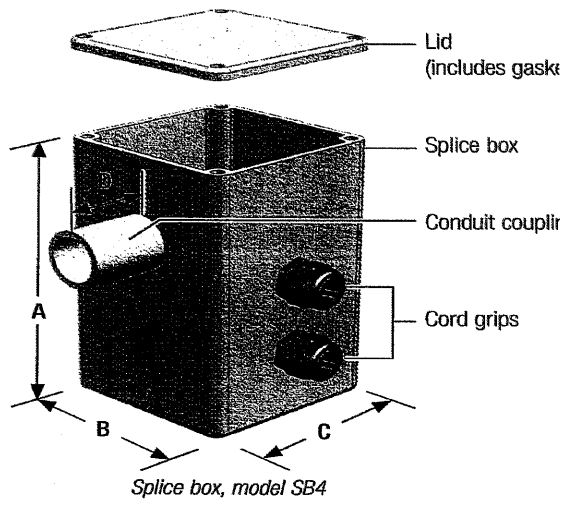

JOB COPY

Input & Output Definitions

The following inputs and outputs have been used with your control panel:

(Fig. 1)

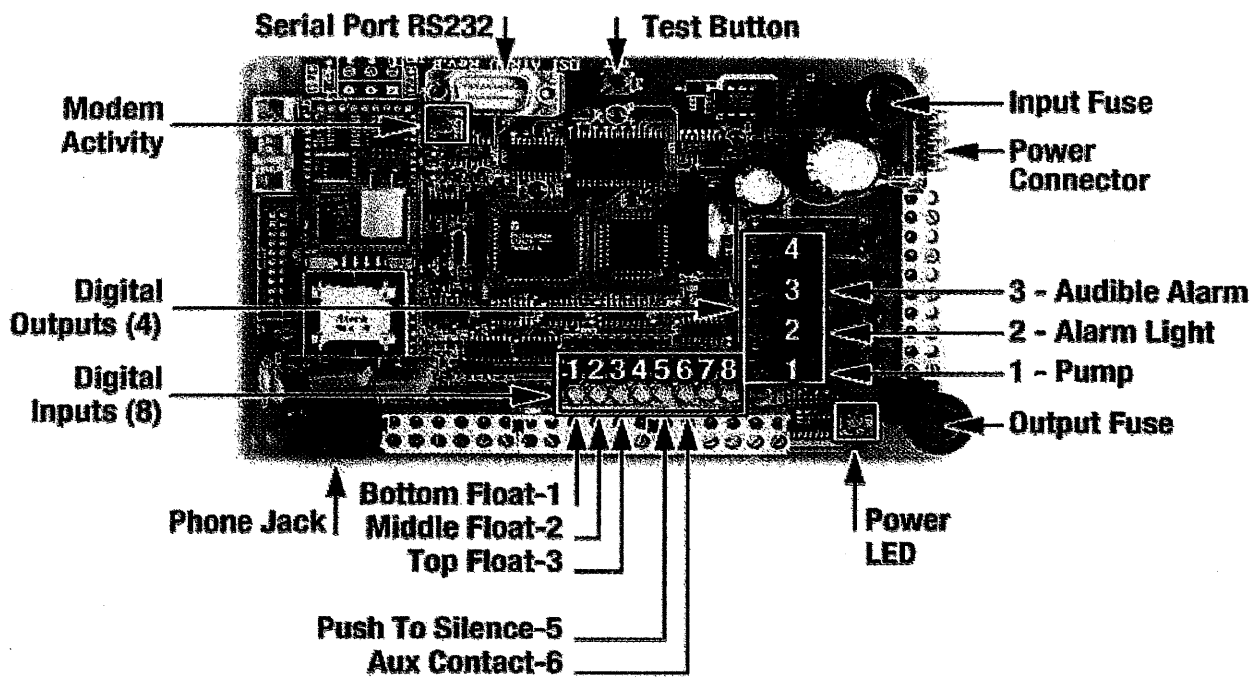

Advantex Pressure Dose Maintenance and Limitations

This septic system **requires annual maintenance and monitoring for the life of the system** and registration with the County for annual maintenance and monitoring.

In order to get your septic "finaled", you (owner) will need the following:

A Maintenance & Monitoring Agreement (with a register Certified Service Provider (CSSP)),

Right of Entry/ Operating Permit (county forms).

For details see the attached maintenance and monitoring requirements.

This septic system is required be installed by an Advantex certified, licensed contractor (A, C-36, or C-42). Preferably familiar with installation of this system. This report is not a construction permit. A permit to install this system must be obtained from the Department of Environmental Health.

Septic tank maintenance should include pumping the septic and cleaning the effluent filter annually. Because the septic tank maintenance is critical to the over-all performance of the sewage disposal system, failure to perform this maintenance can lead to sedimentation and premature failure of the leach lines.

The pump screen should be removed and rinsed off every year. Also the pump, pump float, alarm float, and alarm should be checked for proper operation yearly.

The primary and 100% repair area must be protected from vehicular traffic, corrals, animal enclosures, stables, structures, below or above ground pools, or any other activity that causes alterations such as grading, cuts/fills, etc. Failure to do so may void this report.

Please note that all roof drainage should be diverted away from the septic tank, pump tank, and leach field. Irrigation in the area of the leach trenches should be kept to a minimum to avoid saturating the soil. Drip irrigation should be used.

Also we recommend water conservation should be enlisted for household water use

to maximize the life expectancy of the absorption trenches. Also take care of any household leaks immediately to avoid unnecessary saturating of the leach trenches.

This system has been designed in accordance with the latest industry recognized design standards and County code guidelines. However, the state of the art of sewage disposal design is such that no guarantee can be made as to the length of time that satisfactory service will occur.

Advantex with Pressure Dose Maintenance & Monitoring

This septic system **requires annual maintenance and monitoring for the life of the system** and registration with the County for annual maintenance and monitoring.

In order to get your septic "finaled", you (owner) will need the following:

A Maintenance & Monitoring Agreement (with a register Certified Service Provider (CSSP)),

Right of Entry/ Operating Permit (county forms).

Your Certified Service Provider shall perform the following annually and issue the report to the County Environmental Health Department.

1. Check phone line (or internet connection) for proper operation.
2. Measure crust and sludge in all compartments. The septic tank needs to be pumped on a routine basis every 3 to 5 years, or as needed (when solids are 25%-33%) depending on system usage.
3. Check risers, lids, and seal for proper fit and operation. Check for infiltration. Evaluate inlet tee for buildup inside, and intact with proper slope. Clean inside if needed.
4. Pull splitter valve and hose off in the inlet side of the septic tank.
5. Check water clarity coming out of the filter pod.
6. Disconnect both pump unions.

JOB COPY

7. Check all floats and alarms from proper operation.
8. The effluent filter and Bio-tube filter should be removed and hosed down into the septic tank solid side annually to remove any scum and buildup.
9. Manually run both pumps until water clarity improves and reconnect the pumps.
10. Open filter pod. Flush lines by opening ball valves (one at a time) with pump running. Clean out any clogged orifices. Check squirt height in filter pod and adjust to designer specifications.
11. Check for bio-mat on textiles and make sure filter pod is draining properly. Check air vent for proper operation.
12. Reinsert splitter valve and make sure effluent is getting from splitter valve to discharge tank.
13. Check and record discharge 30-day average, cycles per day, and runtime per cycle. Measure water height in discharge tank and manually run discharge pump for average cycle time. Re-measure water level. Then calculate gallons per cycle by multiplying by cycles per day to calculate average daily usage. Reset recirculation ratio to 4 to 1.

Continued Maintenance for Pressure Dose leach lines

- 1) The effluent filter and Bio-tube filter should be removed and hosed down into the septic tank solid side annually to remove any scum and buildup.
- 2) The pump and alarm floats should be manually activated biannual to verify proper operation.
- 3) Record the reading on the pump cycle counter biannually, once in the middle of summer and once at mid winter. This will allow for approximate water quality usage of wastewater.

- 4) Flush the laterals once a year to remove any accumulated scum. Unscrew the end cap of the clean-outs one at a time. Open up the gate valve and allow effluent to discharge for a few minutes. A flushing valve assembly should be connected to the clean-out assembly to discharge the effluent back into the trench. (See flushing valve detail). If flushing is not performed, the lateral orifices will eventually clog with scum and not operate per design.
- 5) After flushing is completed the pressure head needs to be reset to 5'.
- 6) The drain field effluent head needs to be checked on each lateral annually to assure proper operation of the pump and that orifices are not clogged. Replace the solid end caps on each lateral with an end cap with a 1/8" hole drilled on the top. Be sure all burrs are removed from the holes. Manually turn on the pump and see that uniform head is maintained throughout the distribution system. Replace solid end caps after resetting head pressure.
- 7) Check observation wells for water biannually. Once mid summer and once mid winter. Record date and water level.
- 8) The septic tank needs to be pumped on a routine basis every 3 to 5 years, or as needed depending on system usage.