

200 SERIES

ID MOUNT PIPE BEVELING EQUIPMENT



TRI TOOL
BUILDING PERFORMANCE

Tri Tool manufactures the finest portable beveling machines that deliver maximum precision, reliability and performance



Model 214B

Tri Tool's 200 Series equipment has been the clear choice of experienced craftsmen who know the value of a well-built portable machine tool.

You can count on Tri Tool to deliver the quality you require. We have incorporated years of our customers' on-the-job experience with power utility maintenance, construction, fabrication and oil and gas projects into our designs to ensure maximum performance and durability.

Whether beveling, counterboring, flange facing or single point machining, our rugged equipment produces exceptional and repeatable finishes for superior welding results, critical for today's increased piping system and welding standards.

With a wide range of accessories and state-of-the-art tool bit design, our powerful machines help get the job done quickly and efficiently to meet your most demanding work schedule.

Tri Tool's experienced technical support representatives can help solve the most challenging tasks and assure that you get the right equipment for your next job. We believe in the reliability and quality of our machine tools and back our equipment with thorough customer service, training and warranties.

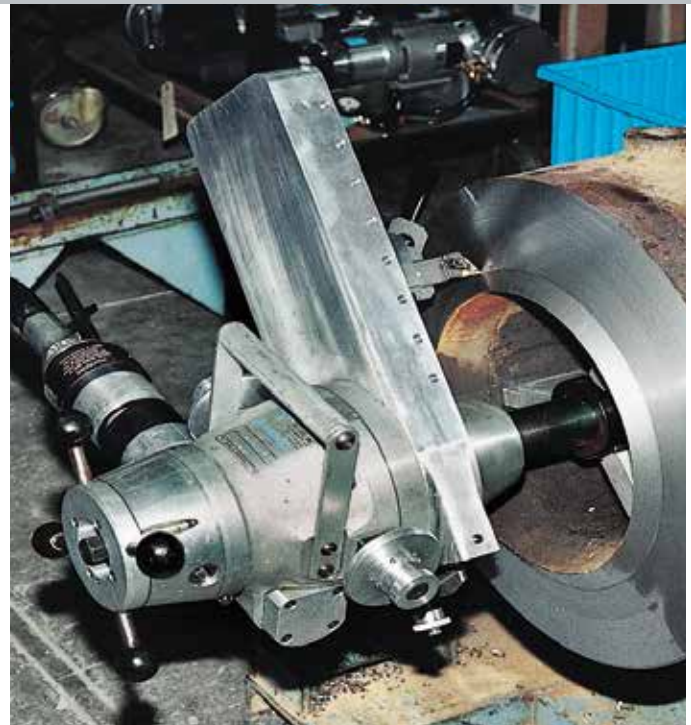

Tri Tool's popular BEVELMASTER Model 214B has been configured with a single point machining module to produce this precision compound bevel on a very heavy wall, flame-cut header pipe.

Visit us at www.tritool.com or call us to speak to our knowledgeable technical sales representatives.



Model 204B

Contents

200 Series Introduction.....	3
Series Overview/Quick Ref Chart	4
Mounting Methods/Durabits	5
Model 204B.....	6
Model 208B/COUPONMASTER	7
Model 214B.....	8
Model 214FF/Single Point Kits.....	9
Model 224B.....	10
Model 236B.....	11
Model 201BA/BOILERMASTER.....	12
Engineering Support.....	13
Specifications.....	14-15
Accessories/Equipment Rental.....	Back

Series Overview

ID mounted tools offer a rapid and dependable method for on-site weld end preparation, flange facing, and other special machining operations.

Our ID mounted end prep equipment utilizes an expandable, self-centering mandrel system which mounts in the open end of a tube or pipe. Jaw blocks, corresponding to the size of pipe being worked on are placed on the mandrel. When a draw rod is tightened, jaw block bases are drawn up an inclined ramp, expanding the jaw blocks against the inside bore of the pipe. This provides a solid, torque-accepting grip for accurate machining operations.

Some tools can be fitted with optional cutting heads that expand the cutting range to cut larger pipes or perform special additional machining operations.

Optional Flange Facing Kits reconfigure your ID mounted BevelMaster into an effective and precision flange facer, perfect for in-place flange maintenance.

Single Point Accessories provide fully adjustable bevel angle machining capabilities. Unlike form tooling where the desired cutting angles are ground into the bit and then transferred to the pipe, single point machining can provide complex weld prep profile within their cutting range.

This capability provides an invaluable means for accurate weld prep machining to meet the most demanding specifications and allows the equipment to perform reliably on the widest range of pipe materials and alloys.

Power for the machines is provided by a variety of dependable sources.

Our machinery delivers maximum performance, flexibility, and cutting options. If your requirements are outside the range of standard equipment or you are dealing with a special material or environment, our customer service representatives will assist you with special equipment solutions for your specific application.

200 Series Quick Reference Chart

- Standard
- Special Order

Model	ID	OD	Mounting Range ¹	Optional Mandrels	Optional Head Kits	Optional Saddle Kits	Elbow Mandrel	Miter Mandrel	Sleeve Mandrel	ID Tracking Mandrel	Flange Facing Module	Single Point Module	Pneumatic Drive	Electric Drive	HD Electric Drive	Hydraulic Drive	Lift Type
201BA	N/A ²	2.0" 50.8 mm		●	●							●	●				Handheld
204B	.610" 15.49 mm	4.5" 114.3 mm	●			●		○		●		●	●				Handheld
BOILERMASTER®	.610" 15.49 mm	4.5" 114.3 mm	●	●								●					Handheld
208B	1.630" 41.4 mm	8.87" 255.3 mm	●			●	●	●	●	●		●		●	●		Handheld
COUPONMASTER™	1.503" 38.17 mm	8.630" 219.20 mm						● ³				●		●			Bench Mount
214B	3.44" 87.4 mm	14.08" 357.6 mm	○			●	●	●	●	● ⁴	●	●		●	●		Handheld
224B	6.813" 173.0 mm	24.0" 609.6 mm					● ⁵	○ ⁶	●	● ⁴	●	●				●	Removable Lifting Frame
236B	11.43" 290.4 mm	36.0" 914.4 mm					● ⁵	○ ⁶	●	● ⁴	●	○				●	Removable Lifting Frame

THIS INFORMATION IS PROVIDED AS A GUIDELINE ONLY TO ASSIST WITH THE SELECTION OF EQUIPMENT AND ACCESSORIES. THIS INFORMATION IS SUBJECT TO CHANGE WITHOUT NOTICE. CONTACT YOUR SALES REPRESENTATIVE FOR SPECIFIC DETAILS OR TECHNICAL SPECIFICATIONS.

Mounting Methods

Whether you are working on pipe, tees, elbows, or doing mitered cuts, Tri Tool has reliable mounting systems for you.

The four mounting systems used on our ID mount equipment provide secure mounting for precision beveling and machining. Special mounting options can be provided for unique cutting operations.

Standard Mandrel

The standard ID mandrel works on the simple principal of tightening a threaded draw rod that pulls an end plate. The end plate drives the ramp blocks up an incline, expanding the ramp blocks against the ID bore, locating the tool - both centered and aligned square to the pipe's center line

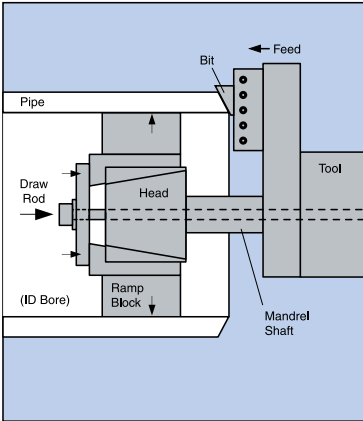

Elbow Mandrel

Where the curves of a tee or elbow prevent the use of ramp blocks, an elbow mandrel grips the fitting with a series of contact pins. The pins slide in and out from the center of the head. A threaded push rod with a tapered end presses the pins outward for secure engagement with the ID bore.

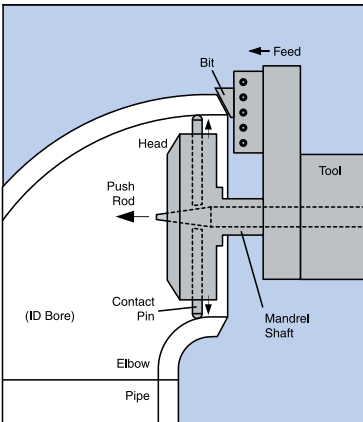

An elbow mandrel head being mounted in a fitting and being aligned with a dial indicator for maximum precision.

Miter Mandrel

Miter mandrels compensate for misalignment, or are used in irregular openings. Individual, threaded contact pins center and secure the head. A unique ball & socket system with bolts on the face of the head adjusts for angular offset up to 5° in all directions.

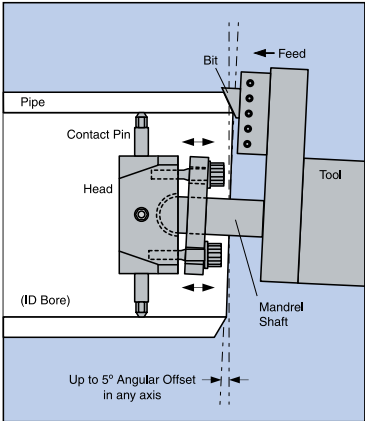

Sleeve Mandrel

The nylon sleeve mandrel is used to protect thin wall pipe from marring. A full-contact expanding sleeve is pressed against the bore by tightening a threaded rod. The rod draws back on an end plate, pulling the sleeve against a tapered core, simultaneously rounding the pipe.

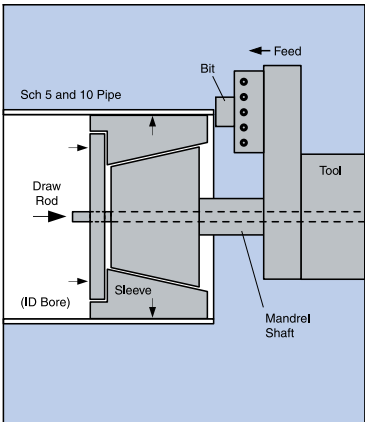

Get maximum performance and tool bit life with Tri Tool's premium DURABIT tool bits.

Our extensive experience as a leading provider of portable machining solutions has resulted in 10,000 unique bit designs that offer better cut consistency, faster cut times, and clean, precision weld preps. We can design and produce custom bits for your special needs to ensure you get the perfect bit for your next project.

DURABIT®



Model 204B

BEVEL MASTER®

*Portable
Precision and
Versatility*



- *In-line feed system*
- *Optional flange facing kit*
- *Optional mandrels*
- *Powerful 1.5 HP motor*
- *Tapered mandrel and spindle bearings*
- *Sealed mandrel shaft prevents contamination*

The Model 204B can be configured as a excellent flange facer with an optional kit

When you require flange facing on smaller flanges, a practical and reliable accessory kit for the Model 204B is a Flange Facing Kit that permits facing up to a 14" surface and mounts on 1.25" to 4.0" pipe sizes.



The Model 204B is a portable ID mount machine tool for beveling, facing and counterboring the ends of pipe or tubing in preparation for welding and will secure to pipe and tubing with an inside diameter from 1.25" (31.8mm) through 4.33" (110.0mm).

The 204B in-line feed system provides excellent cutting control and its heavy-duty cutting head accepts a wide range of bits for increased versatility. The 1.5" feed length is perfect for your deep counterboring and the body has additional mounting holes for additional accessories.

The 204B's mandrel shaft is heat treated to Rc 50 for maximum strength and to minimize wear damage.

Heat-treated mandrel mounting blocks for maximum life and secure mounting and its heavy duty air motor with gear reduction ensures optimum performance.

Model 208B

BEVEL MASTER®

Fabrication and Maintenance Powerhouse



- Simultaneously bevel, face and counterbore
- Optional flange facing kit
- Optional elbow, miter and sleeve mandrel for thin-wall
- Pneumatic, hydraulic or heavy duty electric drive
- ID tracking module

COUPONMASTER™

Produce and recycle heavy-wall weld coupons.



Includes 1.63" to 8.63" ID (Standard) and 1.503" ID (2" XX Super Coupon) mandrels

Built around the Model 208B, the CouponMaster incorporates a strong, integral base stand for bench top mounting. It is perfect for union halls, colleges and trade schools where high numbers of coupons are utilized for the training and qualification of welders with heavy wall pipe.

The extremely rugged and powerful Model 208B has the features you need for dependable weld preps. The machine is rigid, lightweight, and utilizes adjustable torque keys that compensate for wear, eliminating slop and vibration and producing smoother cuts. Elbow mandrel, miter mandrel, and flange facing modules extend machining capabilities. The design of the Model 208B permits an unobstructed view of machining operations. Facing, beveling and counterboring can be performed simultaneously. A 3 HP motor combined with smooth roller bearings make the Model 208B the true industry powerhouse.

Model 214B

*Proven Midrange
Reliability
and Performance*

BEVEL MASTER®

- *Pneumatic, hydraulic or electric drive*
- *Optional single point kit for Beveling and flange facing up to 24"*
- *ID tracking and miter mandrel kit*
- *Form tool or carbide insert cutting*



The dependable Model 214B BEVELMASTER being used in a fab shop to generate a precision form tool weld-prep end on stainless steel pipe.

The extremely versatile Model 214B BEVELMASTER offers a wide working size range with a single standard mandrel. The open design of the tool holders allow for unobstructed viewing of machining operations for simultaneous facing, beveling and counterboring.

Torque key adjustment on the mandrel prevents backlash and vibration, providing smoother cutting. A double enveloping worm gear is used for maximum strength and machine life.

Model 214FF

Powerful Precision Flange Facing

BEVEL MASTER®

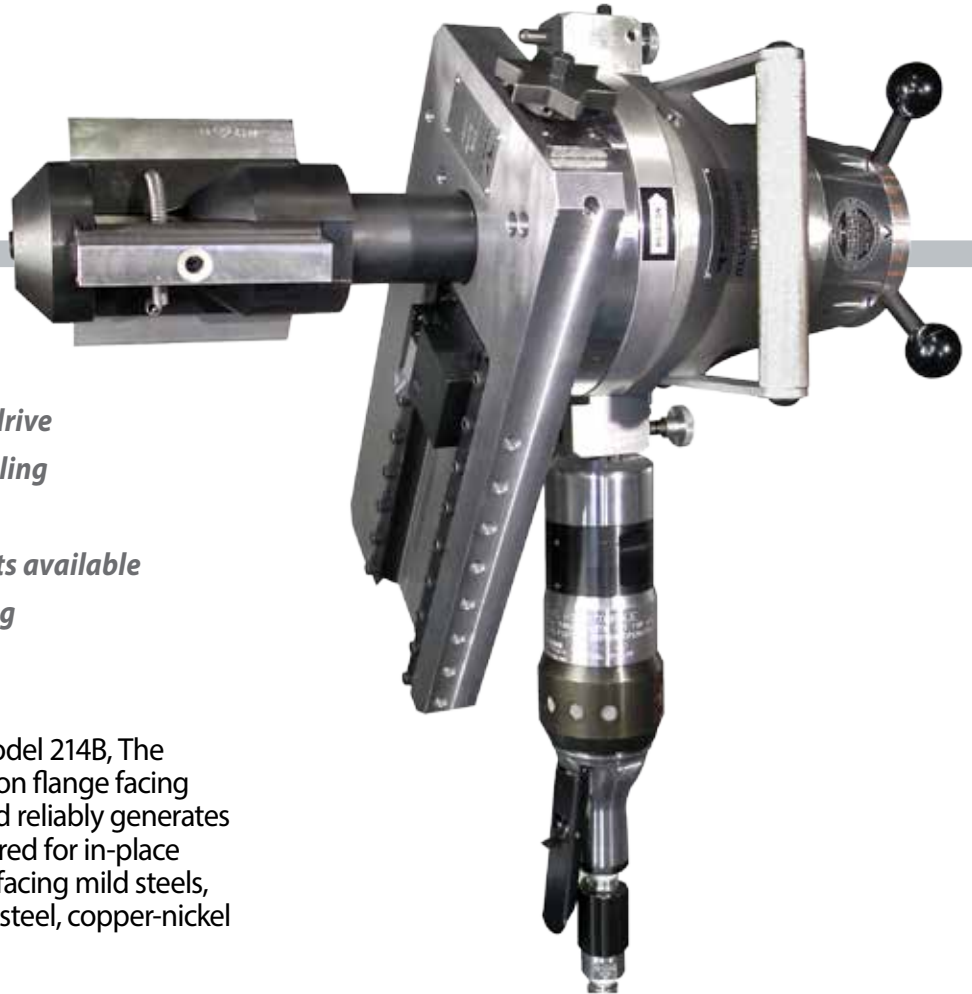

- *Pneumatic, hydraulic or electric drive*
- *Optional single point kit for beveling and flange facing up to 24"*
- *ID tracking and miter mandrel kits available*
- *Form tool or carbide insert cutting*

Building on the proven base model 214B, The Model 214FF features a precision flange facing rotary head that accurately and reliably generates the range of precision finishes required for in-place flange facing. The 204FF is ideal for facing mild steels, chrome steels (Rc 35 max.) stainless steel, copper-nickel alloys, and aluminum.

Single Point Kits

Single point machining allows more flexibility of cut for complex machining operations and compound bevel angles.

Form tool bits can only generate bevel angles predetermined by their cutting surface. Single point machining utilizes generic cutting bits that produce bevels based on the feed angle, and direction of the bit holder. This permits the production of basic as well as compound bevel profiles with the same bit.

Single point kits have been designed to provide extended cutting capabilities for the Model 214B, 224B, and 236B. This means you can perform a much wider variety of end uses with the same equipment without the need to buy additional tools.

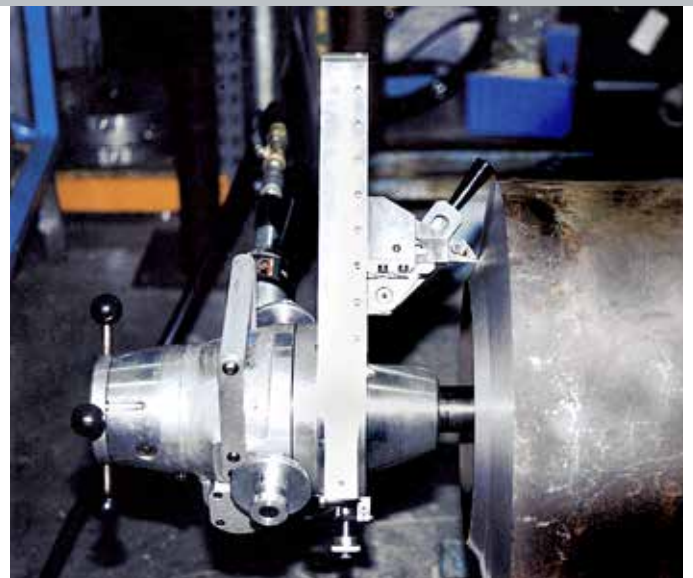

The versatile Model 214B BEVELMASTER with Single Point module generating a precision compound bevel on heavy wall pipe.

Model 224B

The Ultimate Heavy-Duty Beveling Platform

- *Pneumatic or hydraulic drive*
- *Optional single point kit for beveling up to 42" and flange facing up to 50"*
- *Quick change 2 speed gearbox*
- *ID tracking and miter mandrel kit*
- *Pre-loaded ball bearing design provides quiet precision*
- *Heavy duty removable stand & lifting ring*

Tri Tool's Model 224B BEVELMASTER is the premier machine available in the industry for beveling, facing and/or counterboring 8" through 24" pipe, and counterboring IDs greater than 8.5 inch. This machine comes configured with an in-line feed control, precision laser-etched feed increments, and new style grip handles that reduce operator fatigue.

The incredibly smooth action has power to spare thanks to a strong pneumatic drive motor mounted at a right angle to the lathe head.



Tooling extensions permit increased capacity for larger applications.

BEVELMASTER®



The innovative two-speed gearbox enables you to select the optimum gear ratio for the work at hand. Three rugged integrated tooling arms allow for simultaneous machining operations with exceptional precision.

The frame is finished in durable powder coating, and other parts are anodized and nickel plated to resist the corrosion of harsh environments, allowing easier clean up and maintenance.

The Model 224B BEVELMASTER comes complete with (3) tool holders, mandrel, (3 jaw) mandrel head assembly, and upper lifting frame (with optional floor stand), ready to tackle your most challenging jobs.

Model 236B

BEVELMASTER®

Maximum In-Place Machining Power



- Hydraulic drive
- Optional single point kit for beveling up to 60" and flange facing up to 68"
- ID tracking and miter mandrel kit
- Designed for maximum accuracy and reliability
- Long 5" feed travel
- Heavy duty removable stand & lifting ring

The stable Model 236B BEVELMASTER platform provides unique ID mounted machining capabilities for heavy duty weld preparation on 12" to 36" pipe.

The powerful ID mandrel shaft provides superior mounting strength and support that allows rapid setup and a strong, torque-accepting grip. A gear reduction unit on the feed system and adjustable tool modules combine with handy in-line feed knobs for ease of use.

A strong hydraulic motor with worm drive provides maximum power for single point, flange facing, and form tooling. Optional accessory kits include ID tracking, single point/flange facing, miter mandrel, template tracer, and range extension kits.



A Model 236B BEVELMASTER has been modified to include an auto-feed mechanism.

Model 201BA

Note: This is the only 200 Series machine which is OD mounted.

High performance waterwall cutting for .25" to 2" tubes

- *Optional cutting heads*
- *Thin design for cut-out windows*
- *Adjustable clamping*

The lightweight, compact design small diameter bolt-on cutting head of the Model 201BA BEVELMASTER allows it to perform rapid, accurate machining in tight spaces, making it perfect for boiler use.

The OD mounting – no mandrel design (clamps to the outside of tube or pipe) allows this machine to success-



fully work on boiler tubes with inside diameters under 1" with less damage than ID mounting with a mandrel system.

The machine provides rapid clamping saddle adjustments and a right angle feed knob with all controls (feed, clamp, motor) on the outside of the tube panel opening for safe and easy operation. The narrow width of only 1.45" permits use on waterwall cutout windows and between boiler panels.

The Model 201BA's two adjustable saddles cover the full cutting size range.

BOILERMASTER®

Specially designed for 1/4" to 4" boiler pipe machining where its right-angle feed makes it easier to work in confined spaces.

It features a powerful 1.5 HP motor and its compact cutting head accepts standard and wedge-lock



The rugged, ratchet feed, BOILERMASTER seen rapidly facing torch-cut header stubs.

bits for heavy-duty use. A sealed head protects inner components and the milled body houses strong gears with tapered roller bearings for total reliability. The tool steel mandrel and durable hardened

steel mounting blocks provide maximum grip on water walls and pipes making this machine the best choice for boiler construction and maintenance.



The narrow profile and well-designed controls make the Model 201BA BEVELMASTER the ideal solution for waterwall weld preps.

Engineering Support

Tri Tool special engineering and custom manufacturing provides vast experience and state-of-the-art design for unique solutions that produce maximum performance and precision.

Companies have learned to depend on Tri Tool's special engineering services for straightforward and economical solutions to complex pipe cutting requirements. Whether it is a unique environmental problem such as pipe cutting in nuclear power plants where remote operation is a must, or cutting where space limitations preclude the use of typical machines or accessories, equipment support is provided through the modification of existing products or with completely custom tools.

Extensive design experience and state-of-the-art computer design capabilities allow us to provide superior equipment of uncompromising strength and performance.

Clamping - Custom designs can provide special clamping or mounting of cutting tools for thin, odd sized and difficult mounting conditions where standard mounting methods cannot be used.

Materials - Parts, accessories, or entire machines may be manufactured using special materials or coatings to provide for ease of decontamination, prevent corrosion or prevent foreign material contamination of exotic pipe alloys.

Automation - Often customers require machinery configured for high volume or automated production through the use of special base plates, fixtures, feed assemblies, indicators, and tool bit holders. Machinery has been manufactured with automatic feed and shut-off features to increase production and consistency.



A Tri Tool custom manufactured portable saw with a rotary, eccentric feed that was designed to sever steel pipes that were encased in concrete, from the I.D.

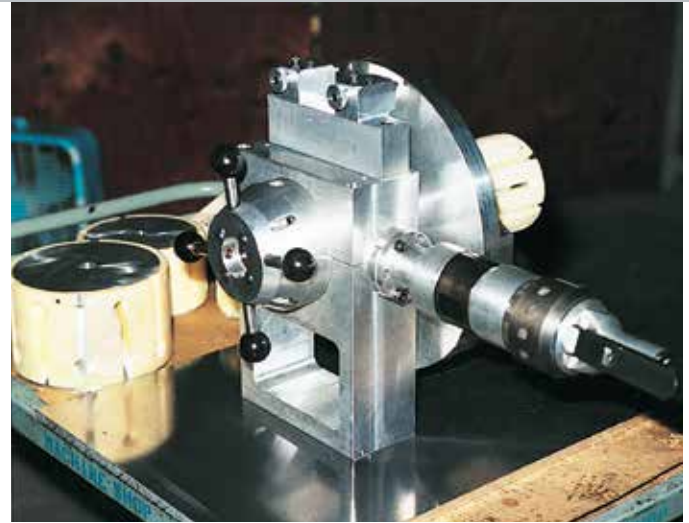

A BEVELMASTER set-up for high volume thin wall tubing production with several optional sleeve mandrels, bench stand, and dual trippers for rapid severing.

Remote Operation - ID mounted equipment can be controlled by special remote consoles or control pendants, allowing the operator to safely and effectively control machining operations in hazardous or space restricted situations. Video cameras and lights can be mounted to allow remote viewing of the procedures or for recording.

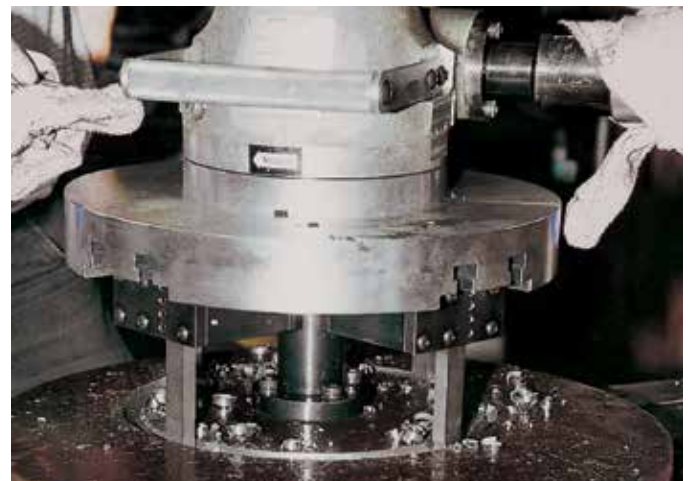

With its power and solid mounting characteristics, a custom BEVELMASTER was perfectly suited for this (four cutting bit) trepanning operation. Note the specially designed bolt-on style mandrel which precisely locates the machine to the work

No matter what your needs are, from a custom tool bit to a complete machine design, Tri Tool's engineering, production, R&D, assembly, and quality assurance personnel are committed to delivering special machinery to you with the same attention to detail, ease-of-use and quality our customers have come to expect.

Contact your sales representative for more information about special engineering services.

Specifications

Model 204B BEVELMASTER®

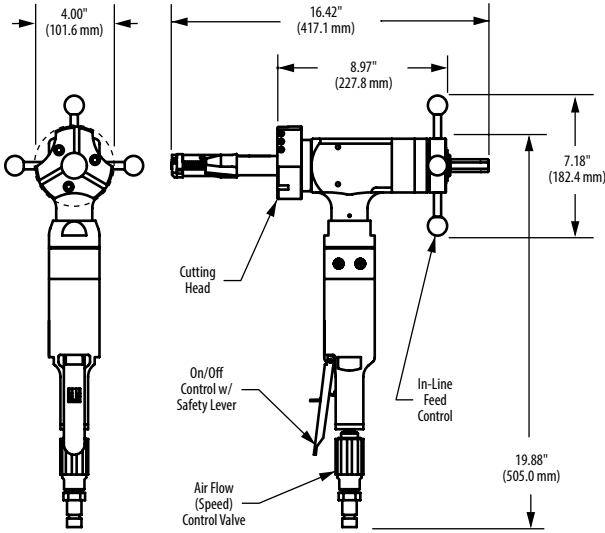

Model 208B BEVELMASTER

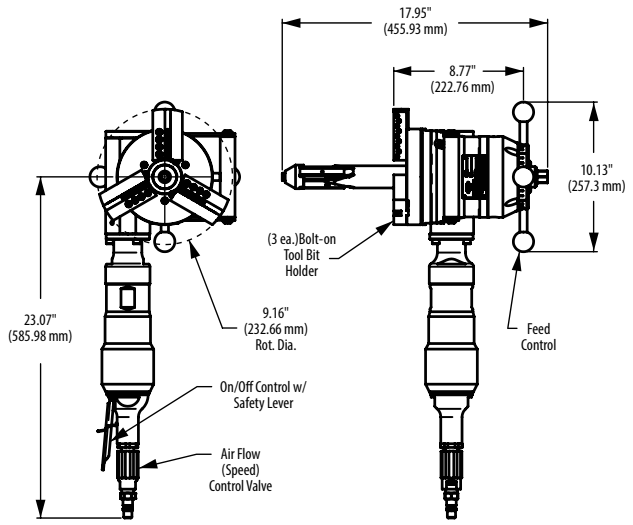

Model	Pipe size Min - Max	Tube Size	Feed Travel	Weight	Absolute Mounting Range
Model 204B	1.25" (42.2 mm) - 4" (114.3 mm)	.610" (15.49 mm) ¹⁰ - 4.5" (114.3 mm) ¹⁰	1.50" (38.1 mm)	18 lbs. (8.86 Kg)	.610" (15.49 mm) ¹⁰ - 4.5" (114.3 mm) ¹⁰
Model 208B	2" (60.3 mm) - 8" (219.07 mm)	1.63" (41.4 mm) ¹⁰ - 8.63" (219.2 mm) ¹⁰	2.00" (50.8 mm)	56 lbs. (25.4 Kg)	1.63" (41.4 mm) ¹⁰ - 8.63" (219.2 mm) ¹⁰

*The Model 204B BEVELMASTER is configured for general purpose pipe beveling whereas the BOILERMASTER is essentially a Model 204 that has been configured with a ratchet feed and features most desirable for use in boiler pipes, water walls, and headers. A full complement of optional accessories are available for each model.

Model 214B BEVELMASTER

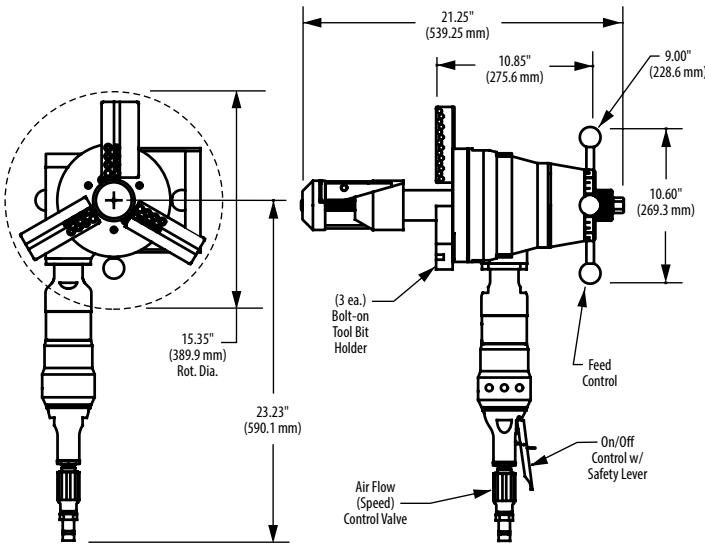

Model 214FF BEVELMASTER

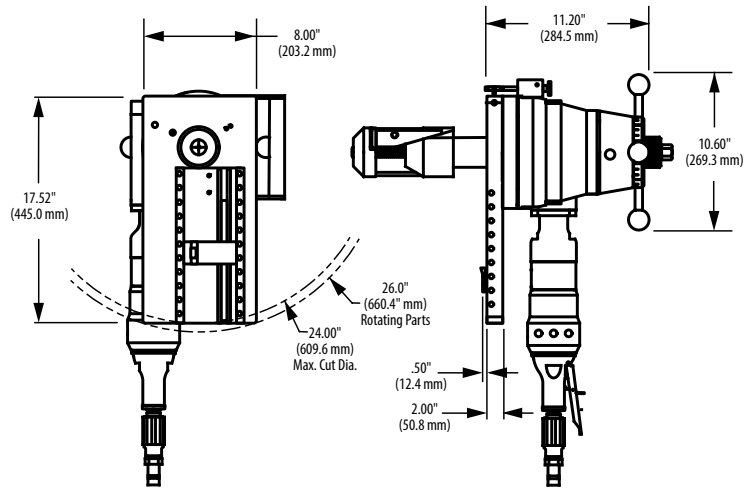

Model	Pipe size Min - Max	Tube Size Min	Feed Travel	Weight	Absolute Mounting Range
Model 214B	4" (114.3 mm) - 14" (355.6 mm)	3.44" (87.4 mm) ¹⁰ - 14.00" (355.6 mm) ¹⁰	2" (50.8 mm)	80 lbs. (36.3 Kg)	3.438" (87.32 mm) ¹⁰ - 14.00" (355.6 mm) ¹⁰
Model 214FF	4" (114.3 mm) - 14" (355.6 mm)	3.44" (87.4 mm) ¹⁰ - 14.00" (355.6 mm) ¹⁰	9.50" (214.3 mm)*	100 lbs. (45.36 Kg)	3.438" (87.32 mm) ¹⁰ - 14.00" (355.6 mm) ¹⁰

*The feed travel lengths for machines are measured axially, with the exception of the Model 214FF feed travel that indicates a radial feed direction.

THIS INFORMATION IS PROVIDED AS A GUIDELINE ONLY TO ASSIST WITH THE SELECTION OF EQUIPMENT AND ACCESSORIES. THIS INFORMATION IS SUBJECT TO CHANGE WITHOUT NOTICE. CONTACT YOUR SALES REPRESENTATIVE FOR SPECIFIC DETAILS OR TECHNICAL SPECIFICATIONS.

Model 224B BEVELMASTER

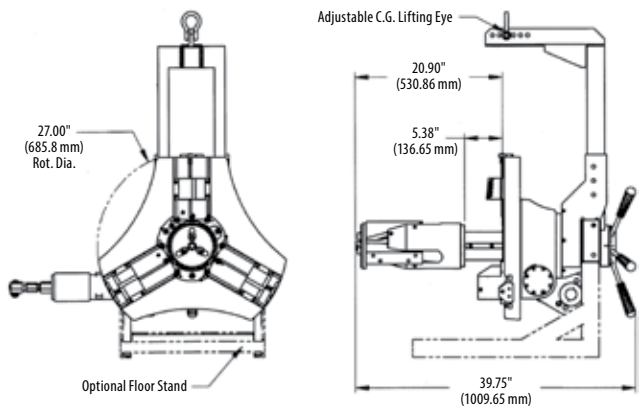

Model 236B BEVELMASTER

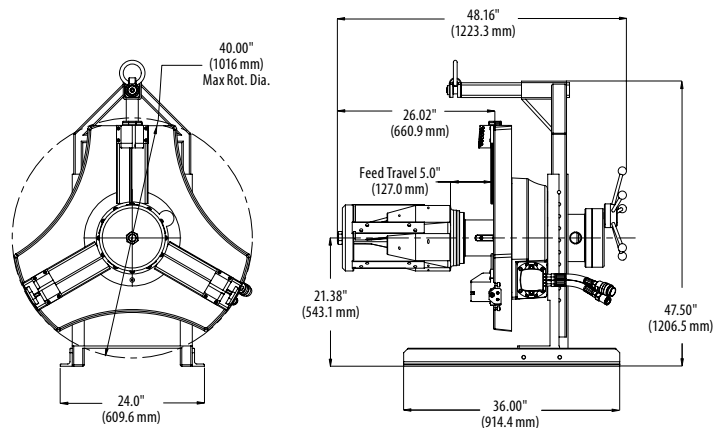

Model	Pipe size	Tube Size Min	Feed Travel	Weight	Absolute Mounting Range
Model 224B	8" (219 mm) - 24" (609.6 mm)	6.813" (173 mm) ^{OD} - 24.0" (609.6 mm) ^{OD}	5.38" (136.6 mm)	420 lbs. (190 Kg)	6.813" (173 mm) ^{OD} - 24" (609.6 mm) ^{OD}
Model 236B	12" (323.8 mm) - 36" (914.4 mm)*	11.43" (290.4 mm) ^{OD} - 36.0" (914.4 mm) ^{OD}	5.0" (127.0 mm)	1200 lbs. (554 Kg)	11.43" (290.4 mm) ^{OD} - 36.0" (914.4 mm) ^{OD}

*Specialized kits extend size range above 36" - call for more information.

Model 201BA BEVELMASTER

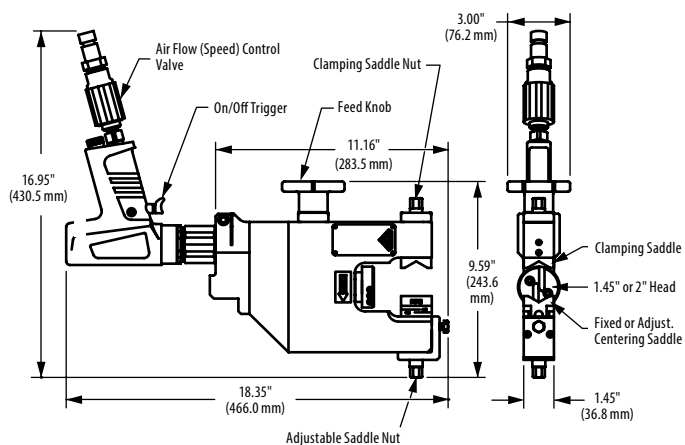

BOILERMASTER

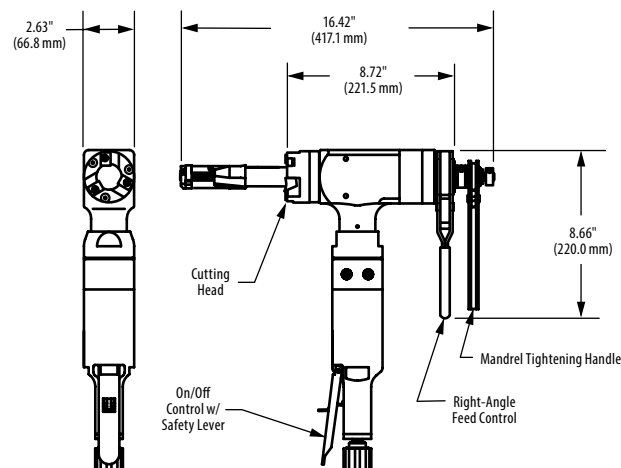

Model	Pipe size	Tube Size	Feed Travel	Weight	Absolute Mounting Range
Model 201BA	0.12" (10.3 mm) - 1.5" (48.3 mm)	.25" (6.35 mm) ^{OD} - 2" (50.8 mm) ^{OD}	.75" (19.05 mm)	15 lbs. (6.8 Kg)	.25" (6.35 mm) ^{OD} - 2" (50.8 mm) ^{OD}
BOILERMASTER	1.25" (42.2 mm) - 4" (114.3 mm)	.610" (15.49 mm) ^{OD} - 4.5" (114.3 mm) ^{OD}	1.50" (38.1 mm)	18 lbs. (8.16 Kg)	.610" (15.49 mm) ^{OD} - OD 4.5" (114.3 mm) ^{OD}

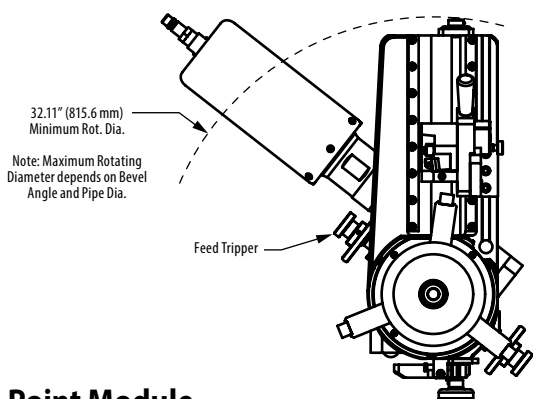

Single Point Module

(Shown mounted on a Model 214B BEVELMASTER)

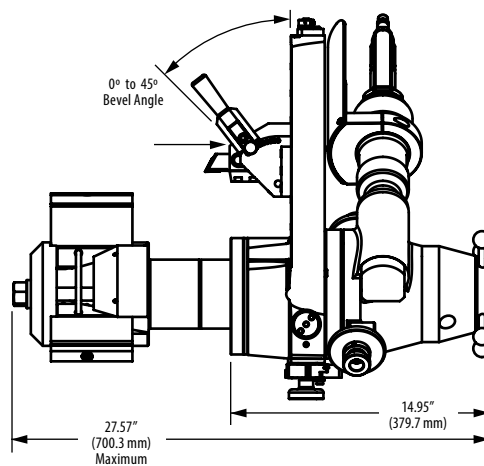

Model	Pipe size	Tube Size	Feed Travel	Weight	Absolute Mounting Range
Model 214B w/Single Point	10.0" (254.0 mm) - 24" (609.6 mm)	8.20" (208.3 mm) ^{OD} - 24" (609.6 mm) ^{OD}	Variable	170 lbs. (77.27 Kg)	3.438" (87.32 mm) ^{OD} - 14.00" (355.6 mm) ^{OD}

Accessories

Cutting Head Kits can be used with some machines to increase the cutting range.

Mandrels and Jaw Blocks are available in sizes and combinations for accurate and solid mounting with the widest range of tube and pipe sizes. Jaw blocks are produced in various materials to conform to your requirements when dissimilar contamination is a concern.

ID Tracking Modules are available for some equipment models that compensate for minor shape variations and out-of-round conditions by utilizing a wheel which tracks the irregular shape, maintaining a consistent cut.

Durable, foam-lined **Carrying Cases** are available to protect your equipment for storage or shipping.



Get maximum performance while protecting your equipment with a rugged, portable "Air Caddy."

Pneumatic Air Lubricators (Air Caddies) are required for use with TRI TOOL® pneumatic tools to properly lubricate the air mechanism, protect the warranty, ensure longer equipment life and maximize performance.

Equipment Rental Options

TRI TOOL® ID Mounted equipment can be rented, providing a cost-effective alternative for projects or unplanned outages.



We maintain a nationwide network of stocked rental facilities to ensure that you get the equipment at competitive rates, when and where you need it. Offices in Rancho Cordova CA, Atlanta GA, Houston TX, and Columbus OH provide localized technicians and parts inventories, and you can return equipment to your nearest facility, saving you money.

With Tri Tool's convenient and flexible rental program, you can try out our equipment before you buy!

Should you decide that you want to buy the rented equipment within the first 30 days of rental, Tri Tool offers a pro-rated schedule that applies rental costs to a purchase price. You get up to a month's rental free!

Renting equipment with the option to buy is a popular and affordable way to experience first-hand, how our equipment can be an important, and versatile, high performance solution to satisfy your in-place machining requirements.

Call today for more information.

© Copyright Tri Tool Inc.
All rights reserved. PN 81-0039 (01-17)



- Portable Precision Machine Tools
- Mechanized Welding Systems • Pipeline Equipment
- Code Welding • On-Site Construction Services
- Special Engineering & Custom Mfg. • Equipment Rentals

3041 Sunrise Blvd., Rancho Cordova, CA 95742
(800)345-5015 (916)288-6100 • www.tritool.com