

300 and 500 SERIES SQUARING AND SEVERING EQUIPMENT



TRI TOOL
BUILDING PERFORMANCE

Tri Tool® produces the finest tube severing and squaring machines delivering maximum precision and performance

Contents

Portable Tube Equipment Solutions.....	3
Series Overview/Quick Reference Chart..	4
Model 300 MICROFACER®	5
Model 301, Model 301 DC.....	6
Model 301SP, Model 301SP DC.....	7
Model 302, Model 304.....	8
Model 306, Model 308.....	9
Model 572AC, Model 576AC.....	10
Model 5712AC, Model 5716AC.....	11
SBCM Series Clamshells.....	12
Special Engineering.....	13
Specifications.....	14 - 15
Premium DURABIT® Tool Bits.....	Back
Model 302 Micrometer Feed.....	Back
SQM Squaring Modules.....	Back

Tube severing and squaring machines are the perfect companions to orbital welding equipment, producing optimal weld preparation for high purity tubing system fabrication and maintenance operations.

Featuring innovative design, quality manufacturing, ultra-precision, and a wide range of custom options, Tri Tool's portable tubing equipment has become the industry standard for quality and versatility.

Our advanced engineering and practical, easy to use design ensure that you get the best possible results and high production rates to save time and money.

Welded tubing system specifications are more exacting than ever before. Tri Tool's tubing equipment has met that challenge with machines that excel in working with difficult-to-cut alloys and clamping systems that address out-of-round so you get perfect welds, every time.

Our tubing equipment performs equally well in production roles with reduced cycle time features such as Quick-lock clamping and Auto Cycling severing systems.

Tri Tool's customers are backed by the industry's best customer support with experienced technical assistance, regional support representatives and special engineering services.

In addition, our online support includes technical reports, white papers, web-based reference materials and educational content, as well as dynamic social media channels.

Contact Tri Tool for tube squaring and severing solutions.



**Pharmaceutical
Semiconductor
Clean Room
Biomedical
Petrochemical
Aerospace and Defense
Food and Beverage**

Series Overview

Tri Tool's wide range of squaring and severing equipment is designed with features that ensure precision, ease of use, high performance and maximum productivity.

Our equipment for squaring and severing tube and pipe is grouped into two primary families, the 300 Series squaring machines and the 500 Series severing machines. The 300 MicroFacer and the versatile SBCM split-frame lathes perform specialized operations.

300 Series machines are designed to provide precise square ends on cut lengths of tube and fittings. The 500 Series SEVERMASTER® machines sever quickly and accurately, and offer squaring capabilities on some models with the SQM Squaring Module accessory. All Tri Tool machines deliver the optimal combination of precision, reliability and portability.



"The consistent quality, precision and high performance of Tri Tool's squaring and severing equipment ensures we deliver our work on time and improves our welding results."

Quick Reference Chart

Model	Operation				Matl. Type			Drive			Features				Working Range (OD)			
	Face (Square)	Sever	Bevel	Deburr	Counterbore	Straight Tube	Microfittings	Fittings	Electric (AC)	Pneumatic	Cordless (DC)	Bench Stand	Squaring Module	Quick-Lock		Stainless Clamping	Storage Case	Auto-Cycling
300MF	●					●	●	●	○	○				●	●			.125" (3.2mm) to .750" (19.1mm)
301	●		●			●		●	○		○		○	●	●			.125" (3.2mm) to 1.102" (28.0mm)
301DC	●		●			●		●		●	○		○	●	●			.125" (3.2mm) to 1.125" (28.6mm)
301SP	●					●	●	●	○	○	○			●	●			.125" (3.2mm) to 1.0" (25.4mm)
301.5SP	●					●	●	●	○	○	○			●	●			.125" (3.2mm) to 1.50" (38.1mm)
302	●					●	●	●	○	○	●			●	●			.1875" (4.76mm) to 2.0" (50.8mm)
304	●		●	●	●	●		○	○	○	●			●	●			.250" (6.35mm) to 4.5" (114mm)
306	●		●	●	●	●		●	○		●		○	●	○			1.0" (25.4mm) to 6.625" (168.3mm)
308	●		●	●	●	●		●	○		●			●	○			1.0" (25.4mm) to 8.625" (291.1mm)
572AC	○	●	○	○	○	●		●	○	○	●	○	●	●	●	●	●	.250" (6.35mm) to 4.5" (114mm)
576AC	○	●	○	○	○	●		●	○		●	○	●	●	○	●	●	2.0" (50.8mm) to 6.63" (168.3mm)
5712AC	○	●	○	○	○	●		●	○		●	○	○	○	○	○	○	8.0" (203.2mm) to 12.0" (30.48mm)
5716AC	○	●	○	○	○	●		●	○		●	○	○	○	○	○	○	12.0" (30.48mm) to 16.0" (40.64mm)
601 SBCM		●	●	○	○	●		●	○	○				●	●			.405" (10.28mm) to 1.315" (33.4mm)
602 SBCM		●	●	○	○	●		●	○	○				●	●			1.315" (33.4mm) to 2.375" (60.32mm)
603 SBCM		●	●	○	○	●		●	○	○				●	●			1.25" (31.75mm) to 3.0" (76.2mm)
603.5 SBCM		●	●	○	○	●		●	○	○				●	●			2.875" (73.0mm) to 4.0" (101.6mm)

This information is provided as a guideline only to assist with the selection of equipment only. This information is subject to change without notice. Contact a Tri Tool sales representative for specific details or technical specifications.

Model 300 MICROFACER®

Delivering big precision in a small package, the MicroFacer is perfectly designed to perform in confined spaces making it the ideal answer for tubing system construction and maintenance.

The Model 300 has been designed specifically to prepare tubes for autogenous welding, squaring .125" (3.2 mm) to .75" (19.1 mm) OD tubing with a wall thickness up to .125" (3.2 mm). This compact, lightweight, precision squaring tool features self-contained OD saddle sets for holding and rounding the tube, rechargeable 9.6V DC power, and an optional 18" flex extension making it perfectly suited for operation in tubing racks.

The powerful DC motor connects to the MicroFacer with a three position bayonet type mounting system for maximum flexibility.

The secure saddle clamping system requires a straight length of .22" (5.6 mm) pipe or tube. The unit is cleanroom ready, being assembled with Krytox® grease and with stainless steel saddles to eliminate carbon contamination.

The Model 300 MicroFacer comes with an AC charger, an extra battery and rugged carrying case.

(Note: The Model 300 can be special ordered as the Model 320, sized for squaring 1" to 2" tubing.)

Micro Squaring - Designed for Cleanroom Use

- *Secure stainless steel clamping components*
- *Long lasting, variable-speed cordless DC motor*
- *Unique cam feed with Auto-Retract reduces cycle time*

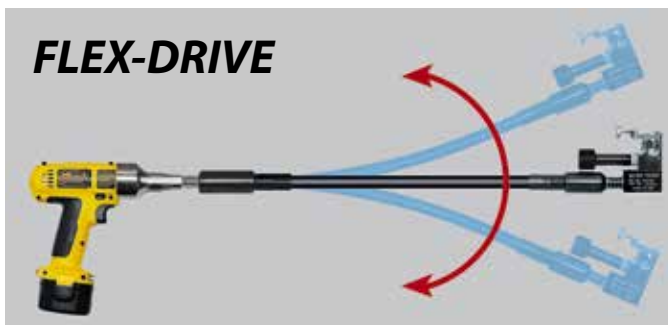

When working in areas of limited or tight access the 18" Flex-Drive is a drive extension that works with both the Model 300 MicroFacer and the OD cutting SBCM Models. The Flex-Drive permits flexible positioning and operation up to 90° off of the center line, in all directions.



Gas cabinets are just one example of a confined work space where the size and versatility of the Model 300 is ideal. The handy Flex-Drive allows the MicroFacer to operate in any orientation.



**Model 300
MicroFacer**



The MicroFacer can produce excellent end preparation on straight lengths of tubing as well as microfittings. Stainless self-contained saddle sets eliminate carbon contamination for autogenous orbital welding and make changing from one size to the next quick and easy.

Models 301 and 301DC

Tri Tool's high performance squaring equipment combines versatility and precision so that you always get quality, repeatable welding results.

Model 301 (w/ Collet Nut)



Over the years, the field proven Model 301 tube squaring machine has set the industry standard for precision and portability. The compact Model 301 provides full support, OD-mounting, self-centering collets and will square .125" (3.2 mm) to 1" (25.4 mm) OD tubing with up to a .125" (3.2 mm) wall thickness.

Precise end preps are easy to accomplish on a wide variety of materials including steel, stainless steel, titanium, Inconel®, copper, aluminum, and plastic with the patented Auto Retract feed system which automatically retracts the bit when the feed handle is released, readying it for the next cut. The cutting head accepts a squaring bit or a combination squaring and beveling bit. Variable speed electric drives and the ability to work without damaging the inside of electropolished tubes makes the Model 301 a perfect companion to orbital tube welding.

A powerful cordless 14.4 variable speed drive is offered for the Model 301DC for remote cutting where AC power is not available or practical.

The Model 301 can be configured with an optional Quick Lock single-throw clamping system that allows rapid cycle times and easy collet size change-over. The Quick Lock system can be retrofitted to all Model 301 machines that utilize the collet nut clamping method.

Get rapid and consistently perfect squaring results - the key to orbital welding success.

- *Get accurate, square, burr free end preparation*
- *Ideal for in-place work and confined spaces*
- *Full contact collet eliminates tube deflection*
- *Patented Auto-Retract cam feed for rapid cycle times*
- *Optional Quick Lock single throw lever clamping*
- *Integrated Micrometer feed indicator*
- *Variable speed AC and three speed variable DC drives*
- *DC drive features audible tone control for consistent feed rate on difficult materials such as Hastaloy® and Inconel®*



Model 301 DC (w/ Quick Lock)



This custom engineered Model 301 has a heavy-duty motor and baseplate, a Quick-lock clamping system and a gear reduction unit to limit the tool bit rotational speed to deal with difficult alloys.

Model 301SP and 301.5SP



Model 301SP



Special saddles for the Model 301SP include dedicated cutouts that correspond with recesses in the tool face to provide the perfect clearances required for squaring gland nut assemblies.

The Model 301SP and 301.5SP are designed specifically for applications such as working with microfittings where a short gripping length is a consideration.

A variety of Short Perch Saddles are available and provide positive grip with as little as .188" (5mm) of straight length.

With a variable speed, high torque motor the machines deliver excellent finishes on all types of materials without damaging electro-polished surfaces. The unit also features excellent visibility and a micrometer-type feed indicator to produce precise lengths.

The Model 301SP offers easy set-up and operation for .125" (3.2mm) to 1" (25.4mm) OD tubing up to .125" (3.2mm) wall, for pipe sizes .250" to .750". It features the patented Auto Retract feed system which automatically retracts the bit when the feed handle is released, making it ready for the next cut. A logarithmic feed cam moves the bit forward quickly at the beginning of the feed action and then slower as the tube is engaged.



Model 301.5SP

The Model 301.5SP offers increased squaring range to .125" (3.2mm) to 1.50" (38.1mm) OD tubing, up to .125" (3.2mm) wall. Equipped with a new toolless, quick change saddle system and transparent integral chip guards, the machine offers superior performance with maximum operator safety. The 301.5SP incorporates Tri Tool's patented Auto Retract Feed and comes in cordless DC (shown) or corded AC versions. An optional base stand is available for high volume precision benchtop squaring operations.



Model 301SP DC

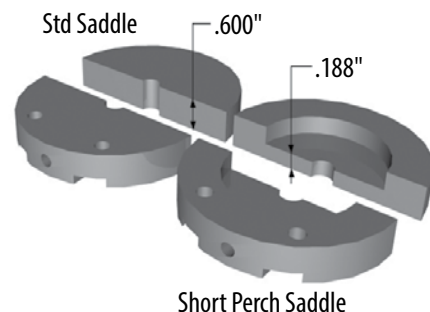

Models 302 and 304

Bench mounted 300 Series tools provide a strong base stand that offers safe and secure operation for high production applications.

The Model 302's size, configuration and capabilities have been optimized for reliability and ease of use. Feature packed, and ruggedly built, the Model 302 provides the precision and time savings our customers have learned to expect. Most importantly, it delivers accurate, repeatable weld prep results every time.

Whether bench mounted or portable, no tools are required for operation. Straight tube or microfittings with ODs of .188" (4.8mm) to 2.375" (60.3mm) and wall thicknesses up to .200" (5.1mm) can be squared with ease. The versatile Model 302 has proven to be a perfect platform for special configurations. Due to its heavy duty construction, the Model 302 can be fitted with an air clamping system. The rugged cast body can be set up for left-hand or right-hand operation. Durable stainless steel clamping saddles are standard and prevent carbon contamination when working with high purity tubing.



Model 302



Model 304

The Model 304 tube squaring machine is a leader in terms of Safety and Performance. It will face .250" (6.35mm) to 4.5" (114.3mm) OD tubing up to .250" (6.35mm) wall thickness. It features quick change saddles (no tools required), graduated feed and a high visibility design to enhance productivity.

The Model 304 offers easy set-up and operation with the accuracy required to consistently achieve flat, square and burr free ends. The cutting head allows installation of up to 3 tool bits for squaring, beveling or special preps, and the bench stand is easily removable for in-place use.

The machine comes with an integral clear chip guard, and a variable speed, dual range drive motor for optimal cutting speed selection and control. Options include air clamping with hand or foot actuation, custom saddle sets for fittings, pneumatic motor, and a sealed DC drive motor.



The 304's open design and integral, clear chip guard provide increased operator safety.

Models 306 and 308

Tri Tool delivers equipment solutions that provide the ideal blend of power and precision for larger diameter production tube squaring.

Nothing compares to the Model 306 for squaring 1" (25.4 mm) to 6.625" (168.3 mm) OD tubing with a wall thickness of up to .250" (6.35 mm).

The rugged and dependable Model 306 shares some of the same features as the Model 304 including Quick change snap-in saddles and a precision micrometer feed.



A Model 304 squaring a section of stainless steel tubing in a cleanroom fabrication work area.

Model 306



The Model 308 for 1.00" (25.4 mm) to 8.625" (219.1 mm) OD tubing (pipe sizes .750" through 8") with wall thickness up to .250" (6.35 mm). These machines offer saddle or collet clamping, and have the capability to square fittings or straight lengths of tube without deformation or damage to the inside surface.

Model 308



Designed for Benchtop Precision, Rapid Cycle Times, and Ease-of-Use

- *Full-support OD mounting*
- *Burr free cutting*
- *Won't damage electropolished surfaces*
- *Optional electric drive for cleanroom use*
- *Easy to change saddles provide positive clamping*
- *Graduated feed indicator*
- *Optional quick change snap-in collets on some models*
- *Unequaled portability*
- *Broad size range*
- *Flexible power and micrometer feed for optimum results*
- *Maximum tool bit visibility and low profile design*

The long feed travel (2") of the powerful Model 308, combined with three tool bit positions permit the machine to perform limited simultaneous beveling, facing and counterboring.

Models 572AC and 576AC

SEVERMASTER®

The 500 Series severing equipment from Tri Tool is the perfect solution for high-volume tube and pipe severing, and welding applications.



Model 572AC

Rapid set-up and cycle times boost productivity

- *Auto-Cycling resets the tool bit after each cut*
- *The adjustable Quick Lock lever accurately and securely clamps with one stroke*

Produces a weld-ready finish

- *Smooth roller bearing design for perfect severs*
- *Secure, self-centering full-contact collet prevents damage and distortion to thin wall tubes*

Minimizes risk of contamination

- *Cold cutting by severing bit produces easily collectible ribbon-like chips*
- *No saw blades that produce particulates*

Our SeverMaster series tube severing equipment was designed to deliver a weld-ready finish for the high purity environment. With 4 models that cover the range of .25" to 16" OD tube, the SeverMaster series has become the favorite of tube production and welding professionals, and the preferred solution for stainless steel tube fabrication.

The SeverMaster's tool bit feed increment is adjustable to perfectly match the material being cut. A variable speed motor provides cutting speed control for longer bit life and ID burr reduction.

The innovative Quick Lock lever actuates a clamping collet with a single stroke, and opens easily to provide rapid collet changes.

After a severing has been completed, an optional Squaring Module can be quickly positioned to square the tube for optimal end finish, length control, and burr elimination.



Model 576AC

Models 5712AC and 5716AC

The larger 12" and 16" SeverMaster severing machines are the ideal solution when working with large, thin wall tube and pipe. Offering both high performance and consistent, repeatable precision, our Model 5712AC and 5716AC produce an excellent weld-ready finish with rapid cycle times.

The Model 5712AC and 5716AC use a hybrid four piece, fixed size collet system with interchangeable saddles to guarantee rapid, secure clamping.



Model 5716AC



Another feature is the screw-style collet actuation mechanism that allows for longer collet movement and clamping pressure, for greatly increased thin wall "out-of-round" correcting capabilities.

The Perfect Weld Prep

- Variable speed motor increases bit life and reduces burrs
- Smooth roller bearing design for perfect severs
- Four interchangeable, self-centering collets prevent distortion of thin wall tubing
- Unique hybrid saddle/collet system, accepts torque while providing reliable, secure clamping

Enhanced Productivity

- Auto-Cycling resets the tool bit after each cut
- Standard dual severing for rapid cutting
- Lockable speed-nut allows fast and easy collet clamping
- Adjustable feed rate and motor speed for cut control

Safety

- Enclosed gears increase operator safety
- Operator friendly foot pedal control

Severing Solutions

- A tube manufacturer used two Model 572ACs to cut tubes to length as they emerged from an extruder. The two SeverMasters performed approximately 22,000 cuts on just one order.
- A nuclear research facility has been cutting fuel rods with a 572AC in a totally remote hot cell since 2004.
- A customer had a requirement to cut 5" diameter military warheads, filled with small projectiles. The reliable Model 576AC successfully cut about 45,000 warheads in a single month.
- Specially designed and modified Model 576ACs were utilized to cut nuclear materials during the cleanup of a weapons grade fabrication facility.

SBCM Series Cutters

The precision SBCM Series low profile collet-mounting clamshells are split frame lathes that produce rapid, reliable severing and beveling of in-line tube and pipe.

Uniquely designed "clamshell" lathes have the ability to split in two for mounting on either side of in-line .125" to 4" in-line tube and pipe in order to perform precision severing and/or beveling. The SBCM Series offers secure collet type clamping that provides not only self-centering, but also protects the work from distortion or damage from clamping forces. Used as a severing tool, the SBCM utilizes the same Flex-Drive shaft as the Model 300 MicroFacer with the same degree of flexibility, making them ideal for use in confined spaces.

SBCMs are protected by a tough Nickel plating that makes them easy to clean and decontaminate. SBCMs can operate with short perch lengths and are sized to cover a wide range of cutting applications. Bits can be specified to provide optimal cutting results on specific materials. Call for more information and application assistance.



**SBCM
Clamshells**



601 SBCM (1/8" to 1" Pipe)

602 SBCM (1" to 2" Pipe)

603 SBCM (1.25" Pipe to 3" Tube)

603.5 SBCM (2.5" Pipe to 4" Tube)



FLEX-DRIVE

The SBCM Series have been designed to operate with the versatile Flex Drive shaft for maximum flexibility - perfect for tight, confined spaces. The Flex Drive attaches by a three position, quick-detachable bayonet lug connector for rapid and secure set up and ease of use at any angle.

Clamshell Performance with Small Tube and Pipe

- Collet mounting - prevents deforming thin wall tube
- Simple, dependable, precision in-line cutting
- Sever and weld prep in one simultaneous operation
- Compact design - perfect for low radial profile operation
- Flexible drive shaft option with quick-detach three position bayonet style mounting
- The perfect machining solution for field tie-ins

Engineering Support

When your work requirements are beyond the scope of our standard machinery, Tri Tool® can provide solutions for your unique machining application.

Tri Tool can extend the cutting range of standard tools, automate operations, enable difficult tolerances to be met or enable machines to perform unusual cuts. Special clamping fixtures can be produced that allow machinery to securely hold specific fittings or tubing assemblies, and specialized form tool bits can be designed to produce complex cutting results.

Tri Tool is proud of our record of consistently providing the industry's finest design, engineering, and manufacturing support. Over the years, we have produced countless variations of our standard equipment. Machinery can be built from special materials, special accessories developed, or completely new machinery built to customer's specifications.

Tri Tool machinery can be modified for maximum productivity or specific purposes. Examples include remote control panels and other specialized controls designed to provide operation in hazardous or confined environments, alternate drive sources such as pneumatic and AC or DC electric drive motors, specially engineered collet and saddle systems to grip unique components, and automated feed and clamping systems.

Used in cleanrooms of varying classes, these machines offer the advantage of cold cutting which generates



This 576 AC SeverMaster® was designed for use in a glove box. Configured with roller cutters, it performs remote chipless canister opening. Other unique features include a pivoting base stand, laser pointer for cut location reference and a burnishing module to push the burr out of the way to allow removal of the inner can.

a continuous chip, rather than the particulate matter produced by saws and abrasive cutters. This provides more control over cleanroom contamination.

When required, machinery can be designed to cut by means of alternative methods such as roller wheels. Roller wheel cutters are important for use where no chips or cutting debris can be produced (as with radioactive materials) or where space is extremely limited.

Trust Tri Tool for your toughest work requirements.



This 500 Series SeverMaster® shows the versatility and flexibility of the product range. Designed for use in hazardous use in a nuclear plant, it offers total remote control operation and unique roller wheel cutting for reduced cutting debris with radioactive metals.



Tri Tool can modify stock tools for specific application requirements. This Model 302 has been configured with pneumatic saddle clamping actuation and a quick-detach air fitting for increased cycle times in a high volume tube production role.

Specifications

Model 301

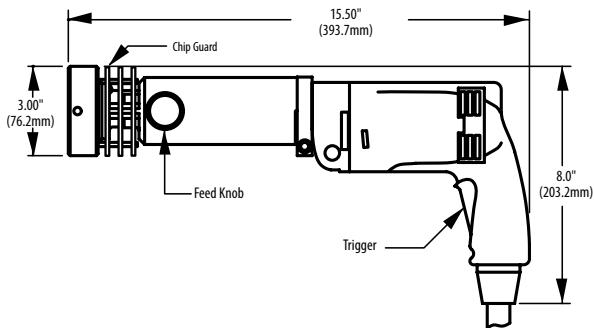

Model 301DC

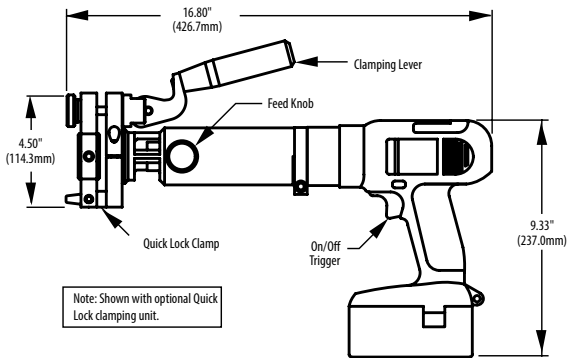

	OD Mounting Range	Max Wall	Collet Clamping Length	Saddle Clamping Length	Short Perch Clamping Length	Tool Bit Travel	Weight	Power Required
Model 301	.125" (3.2mm) - 1.102" (28mm)	.125" (3.2mm)	.120" (30.5mm)	N/A	.187" (4.75mm)	.200" (5.1mm)	8.5 lbs. (3.86 Kg)	120VAC, 220VAC, Pneu.
Model 301 QLDC	.125" (3.2mm) - 1.102" (28mm)	.125" (3.2mm)	.120" (30.5mm)	N/A	N/A	.200" (5.1mm)	11 lbs. (5.0 Kg)	14.4VDC

Model 301SP

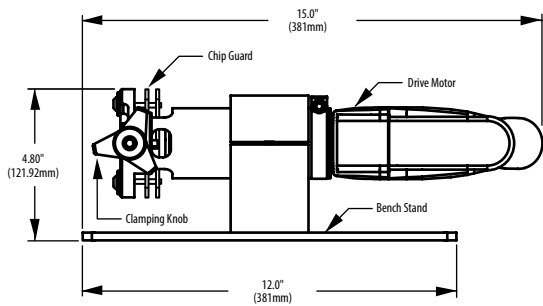

Model 301.5SP

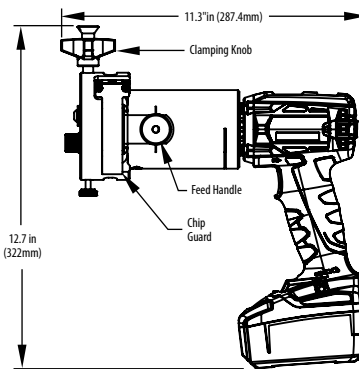

	OD Mounting Range	Max Wall	Collet Clamping Length	Saddle Clamping Length	Short Perch Clamping Length	Tool Bit Travel	Weight	Power Required
Model 301SP	.125" (3.2mm) - 1.125" (28.6mm)	.125" (3.2mm)	N/A	.600" (15.2mm)	.190" (4.8mm)	.200" (5.1mm)	8.5 lbs. (3.86 Kg)	120VAC, 220VAC, Pneu.
Model 301.5SP	.125" (3.2mm) - 1.500" (38.1mm)	.125" (3.2mm)	N/A	.600" (15.2mm)	.190" (4.8mm)	.200" (5.1mm)	9.2 lbs. (4.17 Kg)	120VAC, 220VAC, Pneu.

Model 302

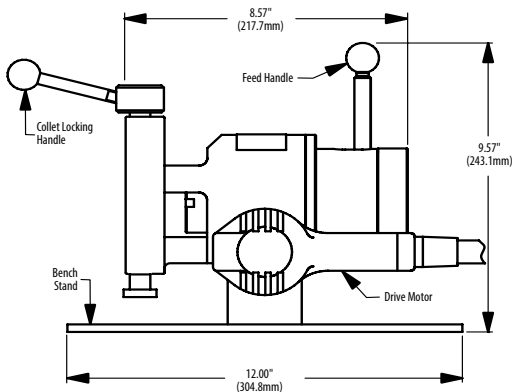

Model 304

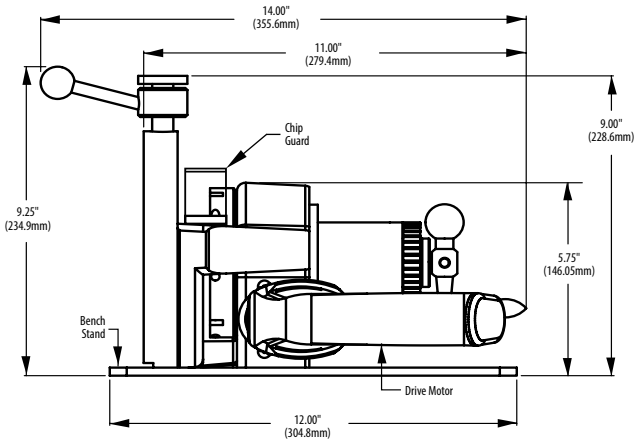

	OD Mounting Range	Max Wall	Collet Clamping Length	Saddle Clamping Length	Short Perch Clamping Length	Tool Bit Travel	Weight	Power Required
Model 302	.188" (4.8mm) - 2.375" (60.3mm)	.200" (5.1mm)	N/A	.875" (22.2mm)	.187" (4.75mm)	.560" (14.2mm)	17.1 lbs. (7.76 Kg)	120VAC, 220VAC, Pneu.
Model 304	.250" (6.35mm) - 4.50" (114.3mm)	.250" (6.35mm)	2.06" (52.3mm)	.875" (22.2mm)	.250" (6.35mm)	.560" (14.2mm)	18.25 lbs. (8.28 Kg)	120VAC, 220VAC, Pneu.

This information is provided as a guideline only to assist with the selection of equipment only. This information is subject to change without notice. Contact a Tri Tool sales representative for specific details or technical specifications.

Model 306

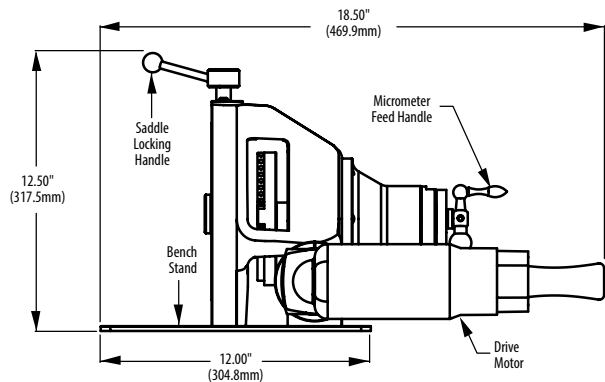

Model 308

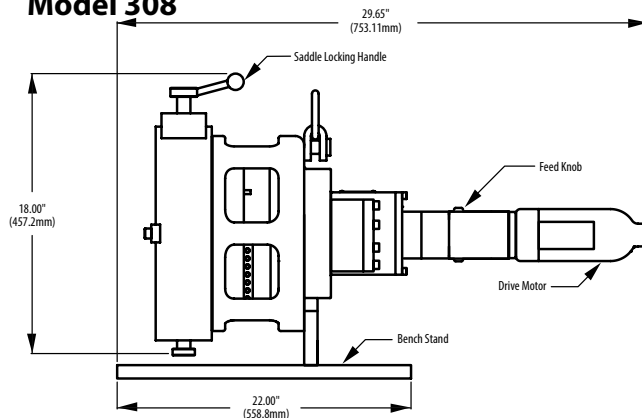

	OD Mounting Range	Max Wall	Collet Clamping Length	Saddle Clamping Length	Short Perch Clamping Length	Tool Bit Travel	Weight	Power Required
Model 306	1.000" (25.4mm) - 6.625" (168.3mm)	.250" (6.35mm)	3.00" (76.2mm)	1.00" (25.4mm)	.250" (6.35mm)	1.00" (25.4mm)	60 lbs. (27.22 Kg)	120VAC, 220VAC, Pneu.
Model 308	1.000" (25.4mm) - 8.625" (219.1mm)	.250" (6.35mm)	3.38" (85.8mm)	2.50" (63.5mm)	.500" (12.7mm)	2.00" (50.8mm)	85 lbs. (39.0 Kg)	120VAC, 220VAC, Pneu.

Model 572AC

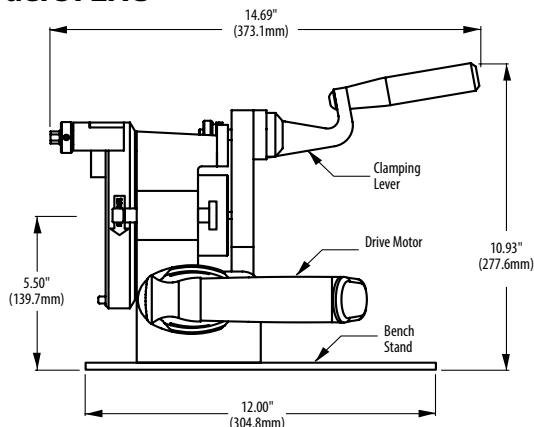

Model 576AC

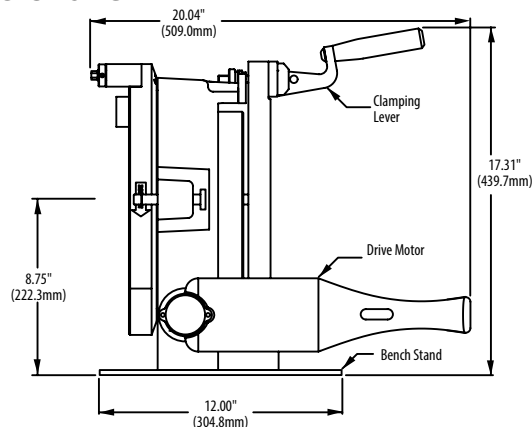

	OD Mounting Range	Max Wall	Collet Clamping Length	Saddle Clamping Length	Short Perch Clamping Length	Tool Bit Travel	Weight	Power Required
Model 572AC	.250" (6.35mm) - 2.00" (50.8mm)	.065" (1.65mm)	N/A	1.38" (35.0mm)	N/A	.001-.005" (.02-.13mm)*	29 lbs. (13.0 Kg)	120VAC, 220VAC, Pneu.
Model 576AC	2.00" (50.8mm) - 6.63" (168.3mm)	.156" (4.0mm)	N/A	3.00" (76.2mm)	N/A	.001-.005" (.02-.13mm)*	93 lbs. (42.2 Kg)	120VAC, 220VAC, Pneu.

*Adjustable - Per revolution

Models 5712AC / 5716AC

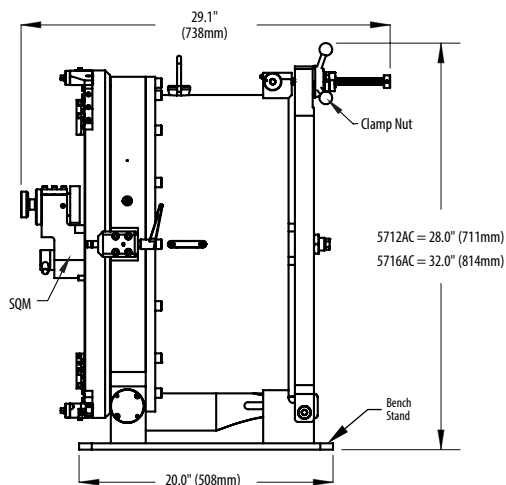

Model 300 MICROFACER®

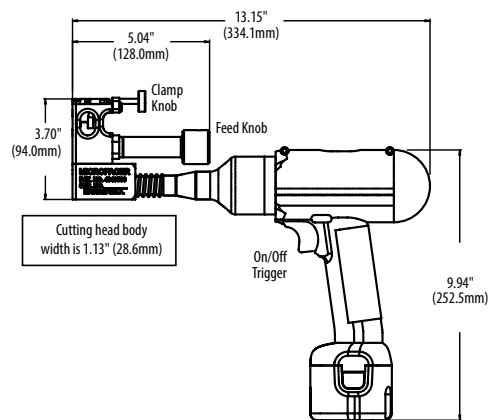

	Cutting Capacity - Tube	Cutting Capacity - Pipe	Max Wall	Clamping Length	Squaring Module	Tool Bit Travel	Weight	Power Options
Model 5712AC	8.0" (203.2mm) - 12.0" (30.48mm)	8.0" - 12.0" (Schedule 5 to 20)	.250" (6.5mm)	9.8" (248.9mm)	SQM-3	.001-.005" (.02-.13mm)*	709 lbs. (321.6 Kg)	120VAC, 220VAC, Pneu**
Model 5716AC	12.0" (30.48mm) - 16.0" (40.64mm)	12.0" - 16.0" (Schedule 5 to 20)	.250" (6.5mm)	12.0" (304.8mm)	SQM-3	.001-.005" (.02-.13mm)*	835 lbs. (379.5 Kg)	120VAC, 220VAC, Pneu**
MICROFACER®	.125" (3.2mm) - .75" (19.1mm)	(SP Clamp Len.) .187" (4.75mm)	.125" (3.2mm)	.40" (10.2mm)	N/A	.200" (5.1mm)	5.35 lbs. (2.4 Kg)	9.6VDC

*Adjustable - Per revolution

**Available by Special Order

Accessories

Premium DURABIT® Tool Bits

Through state-of-the-art design, unique manufacturing, and proprietary coating technology, Tri Tool's patented DURABITs are "free cutting" (the edge stays under the chip) and extremely long lasting. Research and field performance evaluation ensures that our DURABIT tool bits are consistently the highest performing squaring bits available today. Performance, reliability, durability, economy – the best bit for your job is a DURABIT!

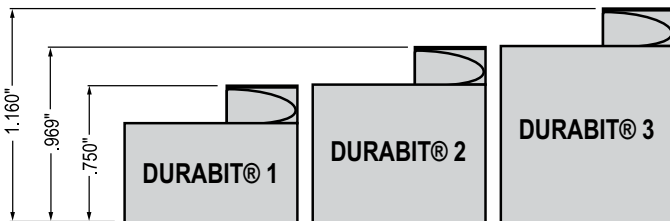

NOTE: Patented DURABIT tool bits, designed for use with Tri Tool's 300 Series squaring equipment are made in three different lengths so that their entire cutting range is possible when using different saddle sets. On Model 301, tubing sizes under .25" require "reverse dogleg bits." Tri Tool will assist you in determining exactly the best bits for your specific requirements.



Tri Tool offers an easy to use, money saving Tool Bit Resharpener Program.

Used bits can be returned to Tri Tool for expert evaluation. Many of your bits can be reground to restore the cutting edge at a much lower price than new bits.



Model 302 Micrometer Feed

For ultra-precision squaring where control of the depth of cut is a critical factor, an optional micrometer feed assembly is available for the Model 302.



SQM - Squaring Modules

An option to increase the squaring capabilities of your SeverMaster severing machine

After a sever is complete, the Squaring Module can be quickly positioned to more precisely square the tube end. The SQM's manual feed provides the operator with maximum control of the depth of cut.

© Copyright Tri Tool
All rights reserved. PN 81-0036 (7-16)



- Portable Precision Machine Tools
- Mechanized Welding Systems • Pipeline Equipment
- Code Welding • On-Site Construction Services
- Special Engineering & Custom Mfg. • Equipment Rentals

3041 Sunrise Blvd., Rancho Cordova, CA 95742
(800)345-5015 (916)288-6100 • www.tritool.com

